

**IMPORTANT! Read and save these instructions.
This manual to be left with the equipment.**

PLANNING AND INSTALLATION INSTRUCTIONS

Condair HumiLife - The flexible room solution
Condair MN

Thank you for choosing Condair

Installation date (MM/DD/YYYY):

Commissioning date (MM/DD/YYYY):

Site:

Model:

Serial number:

Contact

Condair Ltd.

2740 Fenton Road, Ottawa, Ontario K1T3T7

TEL: 1.866.667.8321, FAX: 613.822.7964

EMAIL: na.humilife@condair.com, WEBSITE: www.condairhumilife.com

Proprietary Notice

This document and the information disclosed herein are proprietary data of Condair Ltd. Neither this document, nor the information contained herein shall be reproduced, used, or disclosed to others without the written authorization of Condair Ltd., except to the extent required for installation or maintenance of recipient's equipment.

Liability Notice

Condair Ltd. does not accept any liability due to incorrect installation or operation of the equipment or due to the use of parts/components/equipment that are not authorized by Condair Ltd.

Copyright Notice

© Condair Ltd., All rights reserved.

Technical modifications reserved

Contents

1	Introduction	5
1.1	First things first!	5
1.2	Information about the planning and installation instructions	5
2	For your safety	7
3	Product overview	10
3.1	Product designation	10
3.2	System overviews	11
3.3	System description	15
3.4	Spray circuit design	19
3.5	Options	20
4	Planning a Condair MN system	22
4.1	Note on the water supply to the Condair MN	22
4.2	Determining the number of humidifier units	22
4.3	Configuring the central unit	22
4.4	Calculating cable and hose lengths	23
4.5	Information on positioning the central unit and water filter(s)	24
4.6	Information on positioning of the components of the optional reverse osmosis system Condair RO-HB	25
4.7	Positioning the humidifier units	30
4.8	Water supply requirements	31
4.8.1	Water supply requirements (without RO system)	31
4.8.2	Water supply requirements for the reverse osmosis system Condair RO-HB	31
4.9	Water outlet requirements	32
4.10	Power supply requirements	32
4.11	LAN connection requirements	33
4.12	Information on servicing the Condair MN	33
4.13	Delivery scope overview	34
5	Preparatory installations	35
5.1	Checking delivery / Storage and transport	35
5.1.1	Checking delivery	35
5.1.2	Storage and transport	35
5.2	Tools required for installation	36
5.3	Preparatory installations overview	37
5.4	Preparatory installations for flush-mounting humidifier units in new buildings with concrete ceilings	39
5.4.1	Install installation boxes for flush-mounting in concrete ceilings	39
5.4.1.1	Flush-mounting installation boxes for concrete ceilings	39
5.4.2	Laying the guide pipes	40
5.4.3	Drilling installation openings in the installation boxes	43
5.5	Preparatory installations for flush-mounting humidifier units in suspended ceilings	44
5.5.1	Drill installation openings in the suspended ceilings	44
5.5.2	Laying the guide pipes	44

5.6	Preparatory installations for surface-mounting humidifier units	45
5.6.1	Drill wall duct(s)	45
5.6.2	Laying cable ducts	46
5.7	Installing the central unit and water filter(s) in the housing	47
5.8	Installing the components of the optional reverse osmosis system Condair RO-HB	49
5.9	Setting up water inlet and outlet	50
5.9.1	Information on water installation	50
5.9.2	Water installation overview	52
5.9.3	Installing a drain funnel with trap for peripheral drain module(s)	53
5.9.4	Feeding in hoses and CAN bus cables	54
6	Technical data	57
6.1	Central unit technical data	57
6.2	Humidifier unit technical data	58
6.3	Hose technical data	58
6.4	CAN bus cable technical data	58
6.5	Flush-mounting installation box/guide pipes technical data	58
6.6	Technical data optional reverse osmosis system Condair RO-HB	58

1 Introduction

1.1 First things first!

Thank you for choosing the **Condair MN**.

The Condair MN has been built using state-of-the-art technology and in accordance with the latest safety regulations. However, improper installation and use of the Condair MN may put users and/or third parties at risk and may also cause damage to material assets.

To ensure safe, proper and cost-efficient operation of the Condair MN, please observe and comply with all information and safety instructions in this documentation and in the instructions to the components built into the humidifier system.

Should you have any questions after reading these instructions, please contact your local Condair representative. They will be pleased to help you.

1.2 Information about the planning and installation instructions

Delimitations

These planning and installation instructions are for the Condair MN in its various configurations. Options and accessories are only described insofar as is necessary for proper planning and installation. Please see the relevant instructions for additional information on the options and accessories.

If the Condair MN system is operated with the optional reverse osmosis system Condair RO-HB, the english version of the installation and operation manual for the reverse osmosis system Condair RO-HB can be downloaded using the following QR code:



The information in these instructions is limited to the planning and preparatory installation of a Condair MN system and is aimed at groups of people who are appropriately trained and sufficiently qualified for the work in question.

These planning and assembly instructions are accompanied by various separate documents which are included with delivery. Where necessary, these instructions may refer to these publications.

Symbols used in this manual



CAUTION!

The signal word "CAUTION" together with the hazard symbol in a circle indicates information provided in this documentation which, if ignored, could lead to damage and/or the failure of the device or other equipment.



WARNING!

The signal word "WARNING", together with the general hazard symbol, indicates safety and hazard information given in this documentation which, if ignored, could lead to injury to people.



DANGER!

The signal word "DANGER", together with the general hazard symbol, indicates safety and hazard information given in this documentation which, if ignored, could lead to serious injury or even death to people.

Storage

Keep this documentation in a safe place for further use. If these instructions are lost or if you are unsure whether this documentation is still up to date, please contact your Condair representative.

Language versions

This documentation is available in various languages. For more information, please contact your Condair representative.

2 For your safety

General

All persons tasked to perform work on the Condair MN must read and ensure they have understood the planning and installation instructions as well as the operating manual for the Condair MN before starting work.

An understanding of the content of these planning and installation instructions and the operating manual is a basic prerequisite for protecting personnel from danger, avoiding improper installation and operating the device safely and properly.

All pictograms, signs and markings applied to the Condair MN components must be observed and kept in a clearly legible condition.

Personnel qualifications

All work described in this documentation may only be carried out by trained and suitably qualified staff **authorised by the operator**.

Furthermore, for safety and warranty reasons, interventions may only be undertaken by specialist personnel authorised by Condair.

It is assumed that all persons entrusted to work on the Condair MN are familiar with and abide by the regulations on occupational health and safety and accident prevention.

Proper use

The Condair MN is intended only for direct air humidification of rooms within the specified operating parameters (see operating manual for the Condair MN). Any other use without the written permission of Condair is deemed to be improper use and can render the Condair MN hazardous.

Proper use also demands that all information in this documentation and the operating manual (in particular, all safety and hazard information) is duly observed.

Hazards that may arise from the Condair MN:



DANGER! Risk of electrocution

The Condair MN's central unit runs on mains power. **If the central unit is open, live parts may be touched. Touching live parts may cause severe injury or death.**

That is why the central unit must be switched off and disconnected from the mains power supply (remove the plug from the socket) before the central unit is opened.



Warning! UVC radiation

A UV lamp is built into the Condair MN's central unit. In principle this should pose no risks, as it is installed in a radiation-proof housing. If the UV lamp is operated outside of this housing, harmful UVC radiation may be released. This may cause damage to the eyes and skin.

That is why the UV lamp must never be operated outside of the protective housing. The central unit must be switched off and disconnected from the mains power supply (remove the plug from the socket) before the central unit is opened.



Warning!

Waste from damaged UV lamps may lead to injury and cause damage to human health and harm to the environment.

That is why the waste from damaged UV lamps must be disposed of in accordance with local provisions on hazardous substances and the site of the damage must be cleaned properly.



CAUTION!

Leaky or defective water pipes/connections may lead to water damage.

That is why the central unit and any peripheral drain modules should, where possible, be installed in a technical room with a water outlet that is only accessible to a limited number of people.

We recommend equipping the central unit water outlet with hose breakage protection (washing machine connection, by customer) or with leakage monitoring (by customer), ensuring the water supply if the outlet pipe breaks.

Preventing hazardous operating conditions

If it is suspected that **safe operation is no longer possible**, the Condair MN should immediately **be shut down and secured against accidental power-up. Then, contact the Condair representative.** This can be the case under the following circumstances:

- if components of the Condair MN are damaged
- if the electrical installations are damaged
- if the Condair MN is no longer operating correctly
- if connections and/or piping are not sealed

All persons working with the Condair MN must report any alterations to the unit that may affect safety to the Condair representative.

Unauthorized modifications to the device

No additions or modifications may be made to the Condair MN without the written permission of Condair.

When replacing any defective components of the device, use only genuine accessories and spare parts from your Condair representative.

3 Product overview

3.1 Product designation

The identification of the product is found on the specification label on the right side of the central unit:

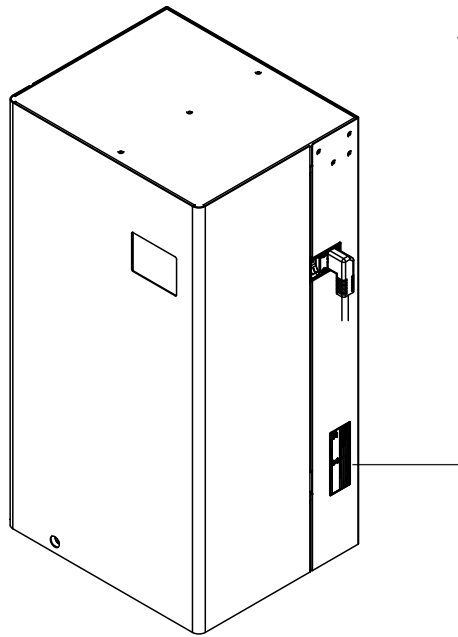
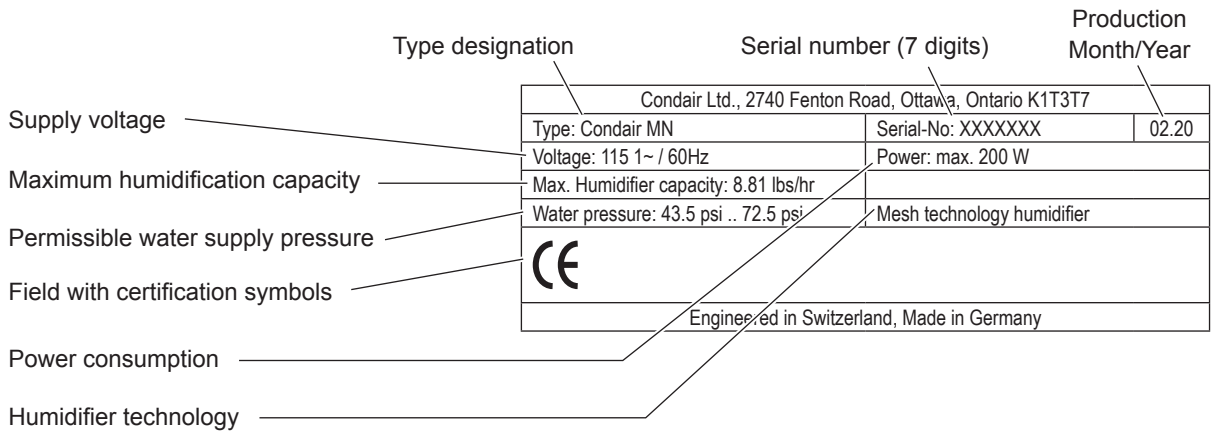
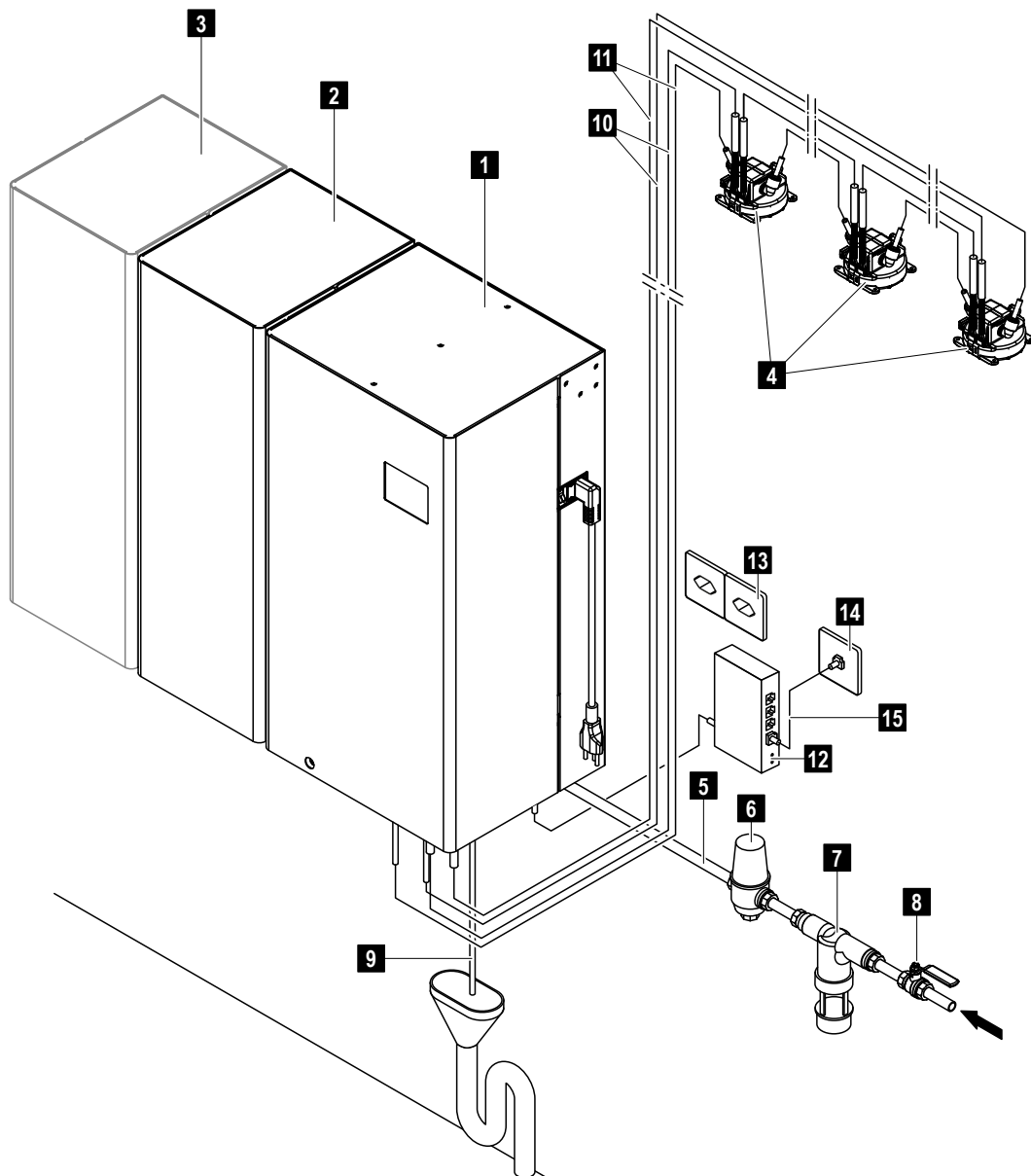

Fig. 1: Location of the specification label

3.2 System overviews



- 1 Central unit with integrated drainage modules
- 2 Water filter in housing (optionally available in free-standing version)
- 3 Optional second water filter in housing or free-standing
- 4 Humidifier units
- 5 Water feed line (provided on site, last 19.7" (50 cm) with reinforced hose)
- 6 Pressure reduction valve (provided on site) for water pressures >14.5 psig (>500 kPa)
- 7 Backflow preventer for fluid category 2 with integrated particle filter (provided on site)
- 8 Water inlet shut-off valve (provided on site)
- 9 Central unit water outlet
- 10 CAN bus cable
- 11 Hoses
- 12 LAN gateway
- 13 Mains power sockets for central unit and LAN gateway (provided on site)
- 14 LAN connection (provided on site)
- 15 LAN cable (provided on site)

Fig. 2: Overview of Condair MN system with central drainage of spray circuit

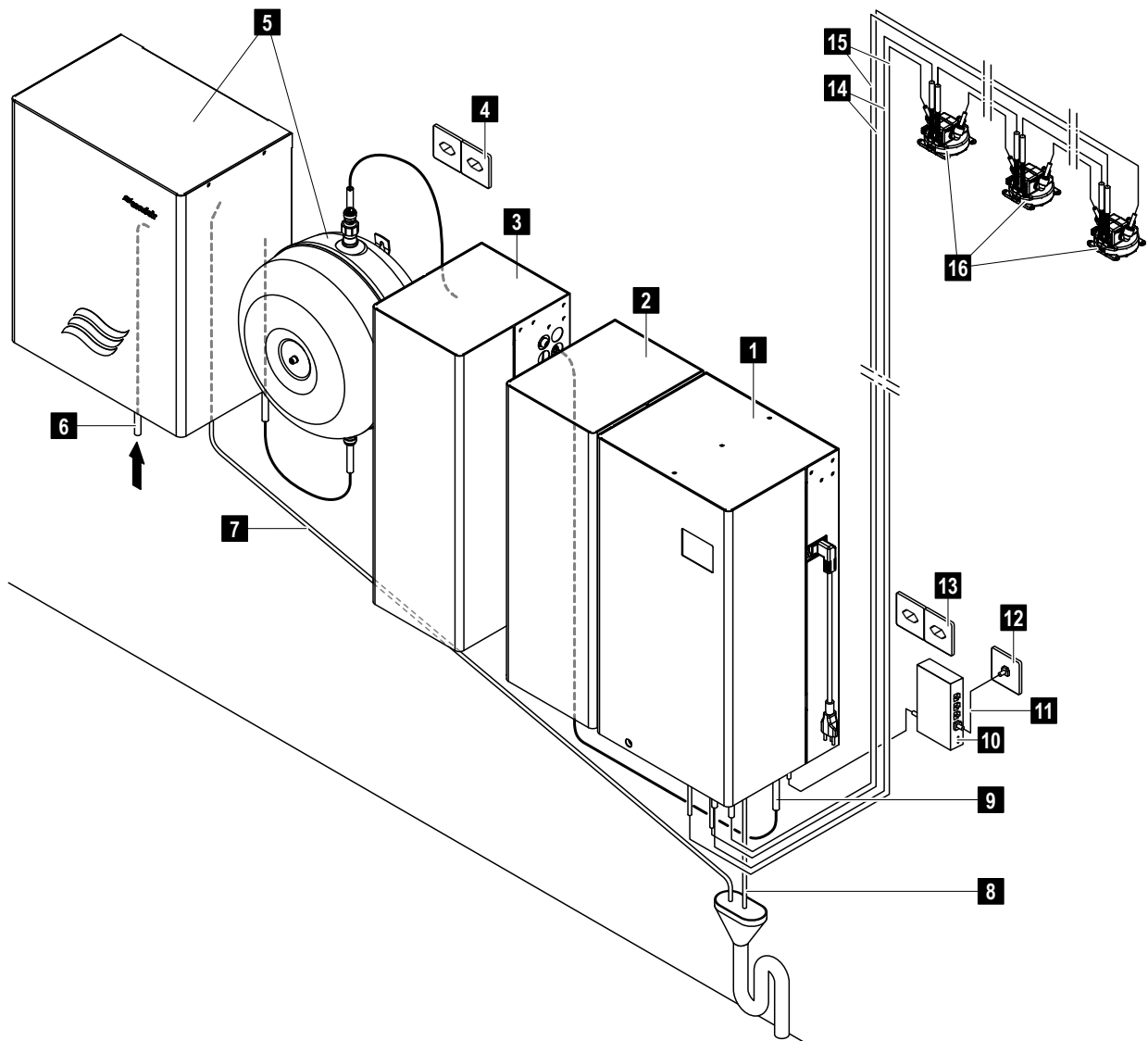

- 1 Central unit with integrated drainage modules
- 2 Water filter in housing (optionally available in free-standing version)
- 3 Booster module
- 4 Mains power sockets for reverse osmosis unit RO-H and Booster module (provided on site)
- 5 Reverse osmosis system Condair RO-HB
(consisting of reverse osmosis unit RO-H and 12 l flow tank)
- 6 Water inlet reverse osmosis unit RO-H
- 7 Drain line reverse osmosis unit RO-H
- 8 Central unit water outlet
- 9 RO water feed line
- 10 LAN gateway
- 11 Mains power sockets for central unit and LAN gateway (provided on site)
- 12 LAN connection (provided on site)
- 13 LAN cable (provided on site)
- 14 CAN bus cable
- 15 Water hoses
- 16 Humidifier units

Fig. 3: Overview Condair MN system with central drainage of spray circuit and reverse osmosis system Condair RO-HB

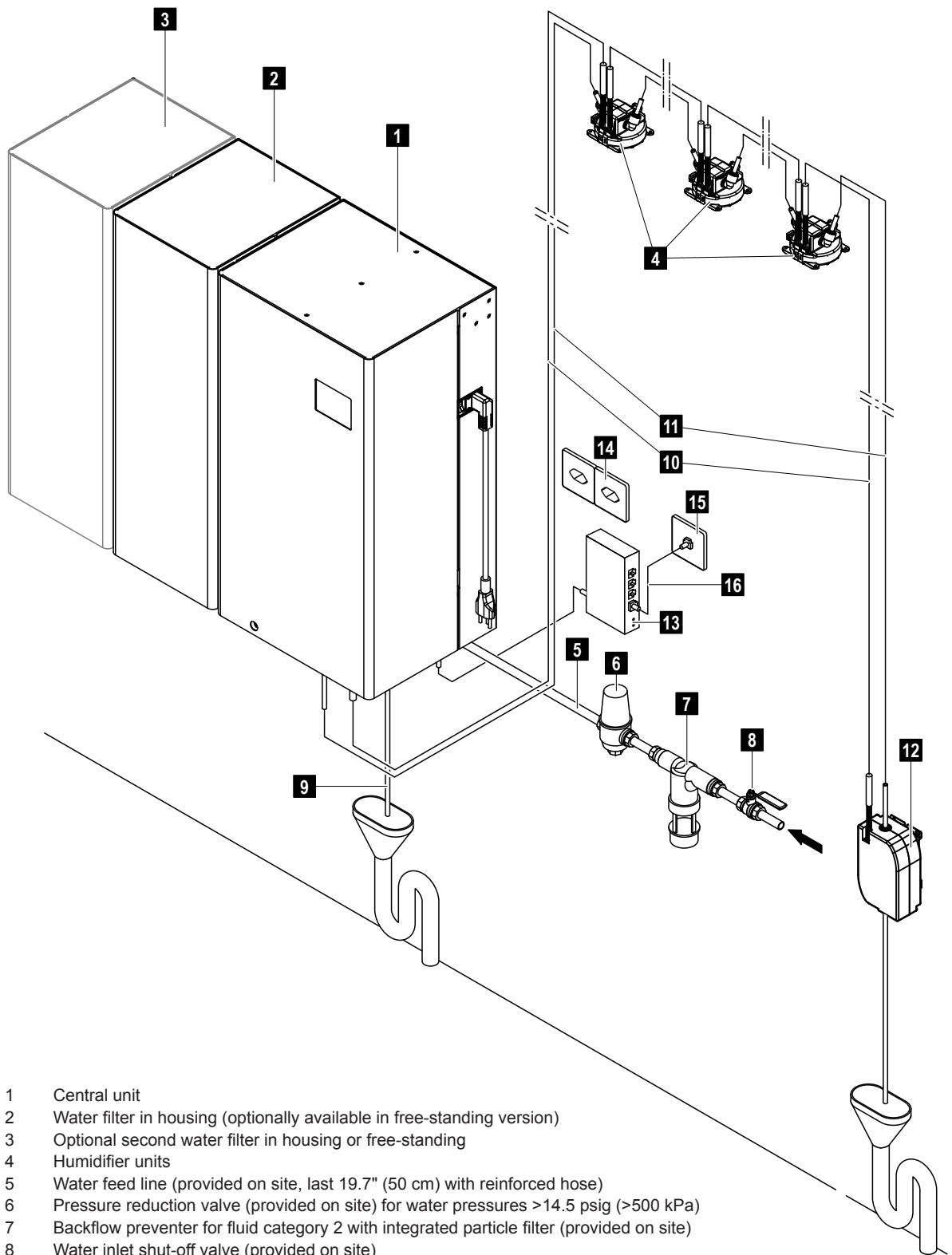

- 1 Central unit
- 2 Water filter in housing (optionally available in free-standing version)
- 3 Optional second water filter in housing or free-standing
- 4 Humidifier units
- 5 Water feed line (provided on site, last 19.7" (50 cm) with reinforced hose)
- 6 Pressure reduction valve (provided on site) for water pressures >14.5 psig (>500 kPa)
- 7 Backflow preventer for fluid category 2 with integrated particle filter (provided on site)
- 8 Water inlet shut-off valve (provided on site)
- 9 Central unit water outlet
- 10 CAN bus cable
- 11 Hoses
- 12 Drainage module (installed externally)
- 13 LAN gateway
- 14 Mains power sockets for central unit and LAN gateway (provided on site)
- 15 LAN connection (provided on site)
- 16 LAN cable (provided on site)

Fig. 4: Overview of Condair MN system with peripheral drainage of spray circuit

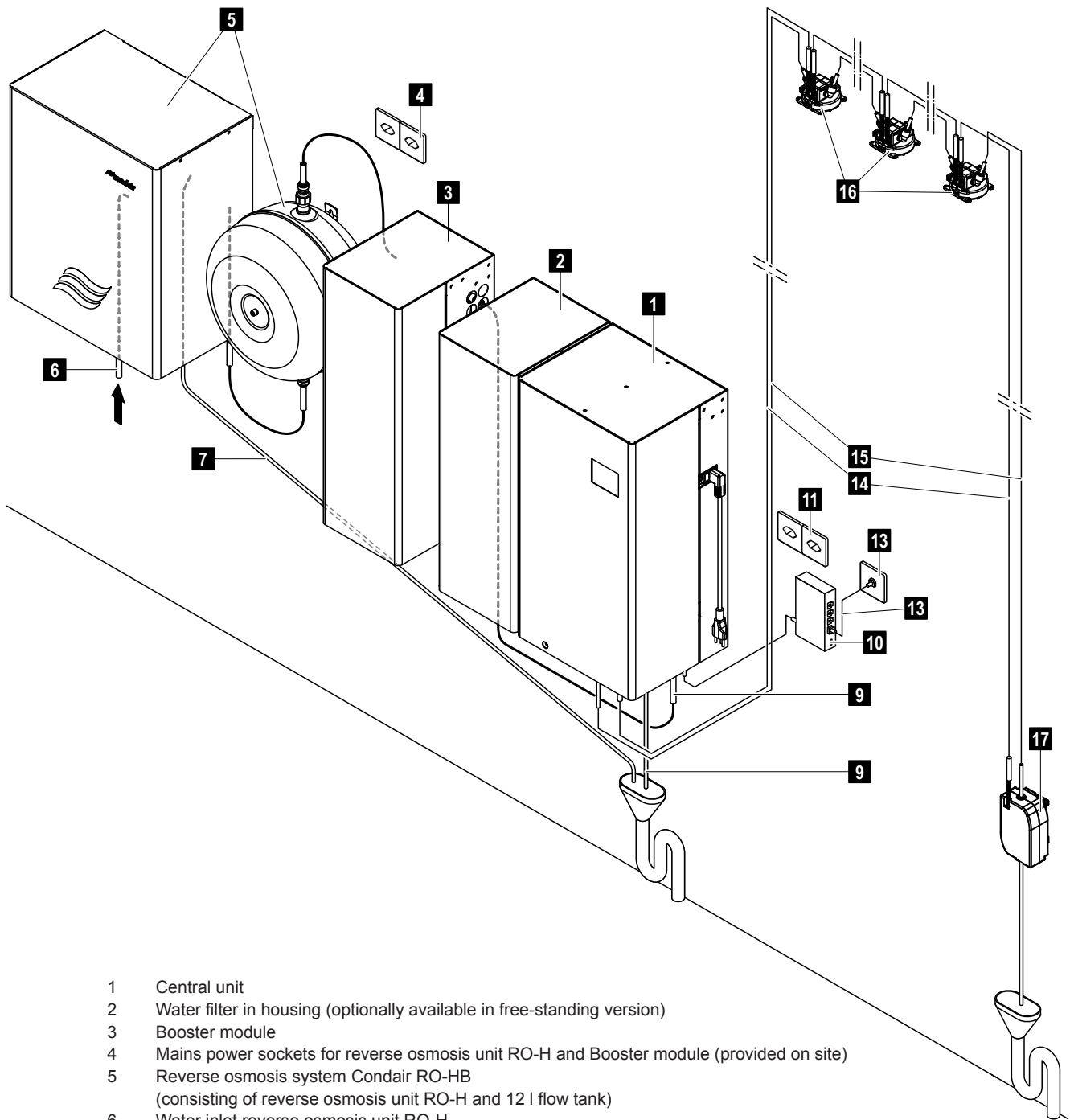

- 1 Central unit
- 2 Water filter in housing (optionally available in free-standing version)
- 3 Booster module
- 4 Mains power sockets for reverse osmosis unit RO-H and Booster module (provided on site)
- 5 Reverse osmosis system Condair RO-HB (consisting of reverse osmosis unit RO-H and 12 l flow tank)
- 6 Water inlet reverse osmosis unit RO-H
- 7 Drain line reverse osmosis unit RO-H
- 8 Central unit water outlet
- 9 RO water feed line
- 10 LAN gateway
- 11 Mains power sockets for central unit and LAN gateway (provided on site)
- 12 LAN connection (provided on site)
- 13 LAN cable (provided on site)
- 14 CAN bus cable
- 15 Water hoses
- 16 Humidifier units
- 17 Drainage module (mounted externally)

Fig. 5: Overview of Condair MN system with peripheral drainage of spray circuit and reverse osmosis system Condair RO-HB

3.3 System description

System design

The Condair MN consists of:

- a central unit;
- a water filter and an optional second water filter (both water filters with or without housing);
- one to max. two spray circuits with maximum 10 humidifier units per spray circuit;
- a central drainage (drain module integrated into the central unit, see [Fig. 2](#)) or a peripheral drainage (drain module installed in a separate room, see [Fig. 3](#)) per spray circuit.

The Condair MN system can optionally be equipped with a reverse osmosis system RO-HB (reverse osmosis unit with flow tank) and a booster module to feed the Condair MN system with RO water (see [Fig. 3](#) and [Fig. 4](#)).

Note: The booster modules are available in a version for single systems (to feed a single Condair MN system) and a version for multiple systems (to feed up to 3 Condair MN systems). **In the case of multiple systems, the individual Condair MN systems can only be equipped with one water filter and one booster module is required for each Condair MN system.**

Installing the humidifier units

The humidifier units are flush-mounted onto a ceiling or wall as standard. In concrete ceilings/walls in new buildings, flush-mounting boxes must be placed in the relevant positions and connected using guide pipes (0.98" (25 mm) in diameter for the insertion of hoses and CAN bus cables). When installing humidifier units in suspended ceilings in new or existing buildings, holes $\varnothing 2.95"$ ($\varnothing 75$ mm)) must be drilled in the appropriate places for the flush mounting of humidifier units in the ceiling. Alternatively, guide pipes must be installed between the humidifier unit installation points (0.98" (25 mm) in diameter, for the insertion of hoses and CAN bus cables).

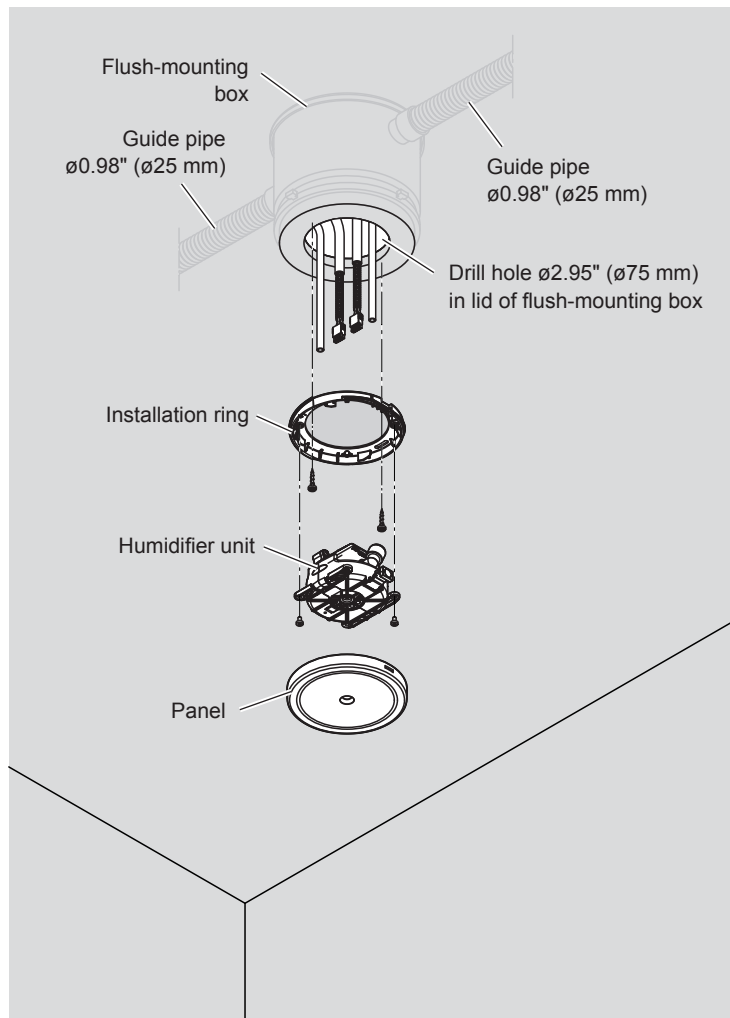

Fig. 6: Concrete ceiling flush mounting

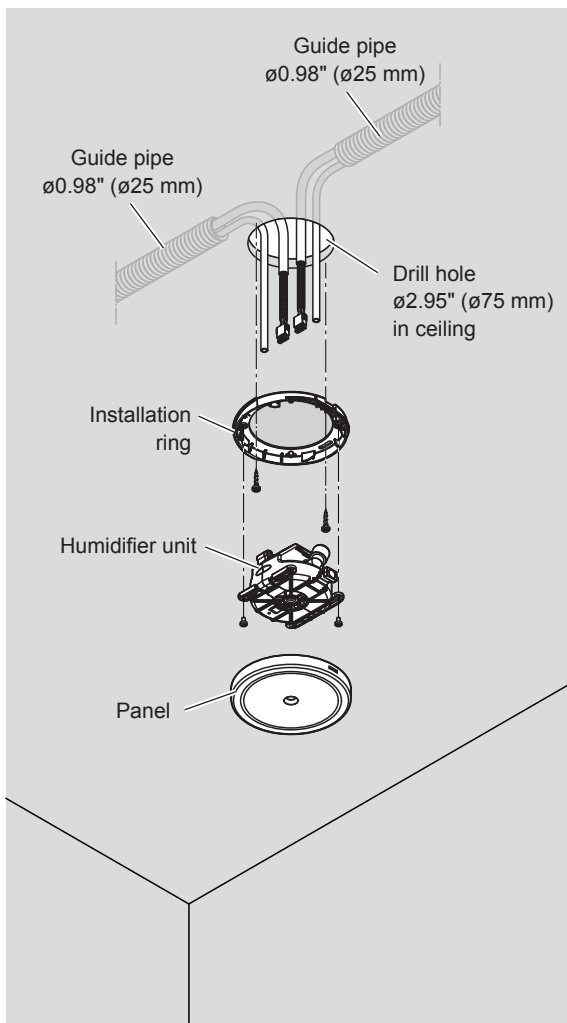

Fig. 7: Suspended ceiling flush mounting: Installation ring screwed to the ceiling

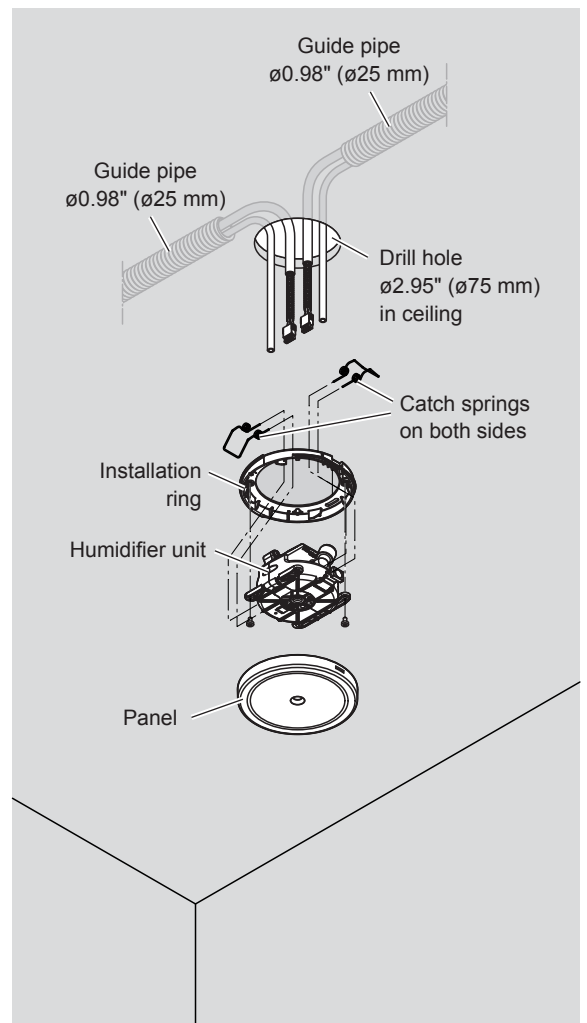

Fig. 8: Suspended ceiling flush mounting: Humidifier unit with catch springs for plugging into the ceiling

Humidification output

The maximum humidification output of a humidifier unit is 1.272 gal/day or 10.58 lbs/day.

This yields the following maximum humidification outputs:

- With one spray circuit with max. 10 humidifier units:
max. 12.72 gal/day or 105.8 lbs/day
- With two spray circuits with max. 10 humidifier units per spray circuit:
max. 25.44 gal/day or 211.6 lbs/day

Power supply

- Central unit: 115 VAC / 60 Hz
- Humidifier units: 36 VDC, supplied by the central unit through a bus cable

Inlet water

- Quality: Drinking in accordance with applicable local drinking water regulations
- Permissible water supply pressure: 43.5 ... 72.5 psig (300 ... 500 kPa)
- Permissible water temperature: 41 ... 77 °F (5 ... 25 °C)
- Water hardness: 50...530 ppm (5...53 °F)
- Conductivity: 5 ... 1000 µS/cm

Note: The permissible values for the inlet water for the optional RO-HB reverse osmosis system can be found in the separate installation and operation manual for the reverse osmosis unit.

Water drainage

- Open drain funnel with trap connected to the building's wastewater pipe.

Hygiene functions

In order to comply with the guidelines set out in VDI 6022, sheet 6, the Condair MN has the following hygiene functions as standard:

- Periodic system flushing
- UV treatment of water
- Permanent temperature control
- Safeguard against system being switched off for too long

Safety functions

- Hydraulics
 - Permanent conductivity monitoring
 - Permanent pipe burst monitoring
 - Periodic leakage monitoring
 - Permanent temperature control
- Electronics
 - Short circuit fuse on spray circuit

Remote operation/monitoring

Connecting the Condair MN via a LAN gateway enables online access and monitoring of the system.

3.4 Spray circuit design

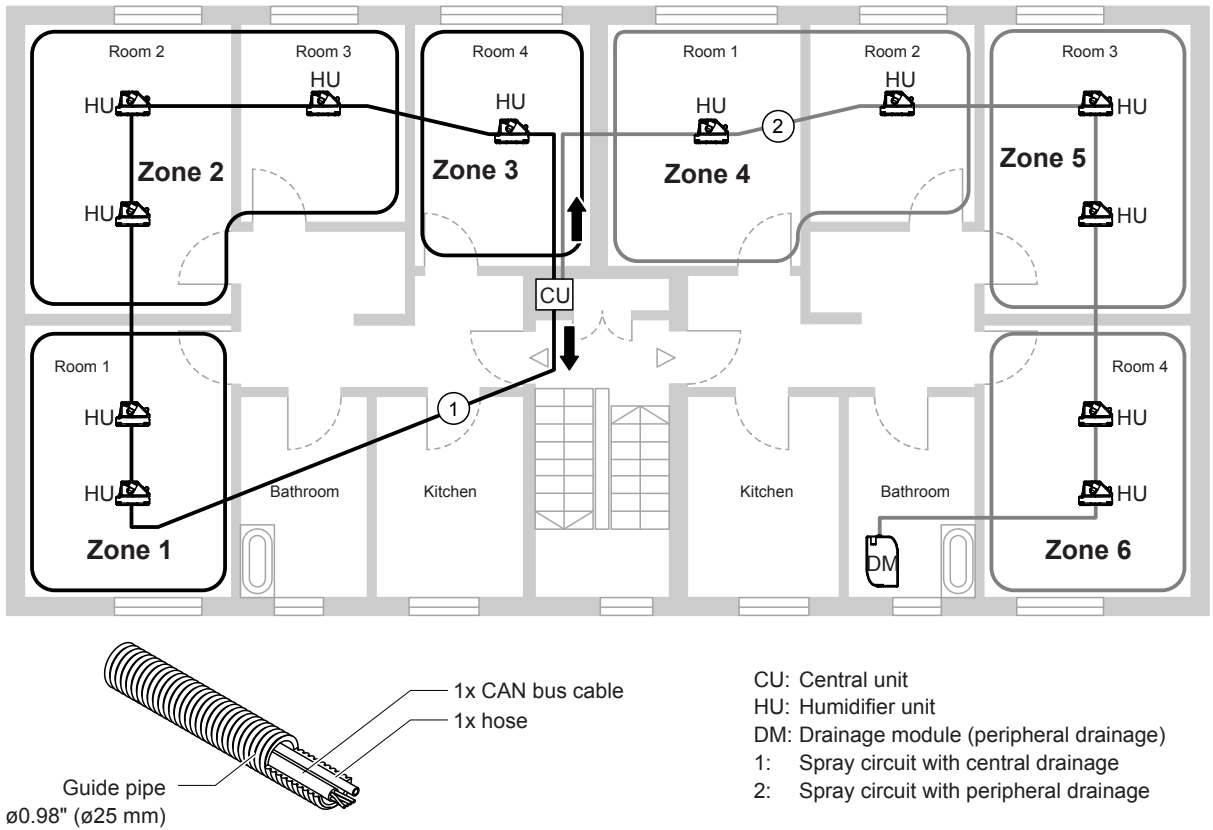
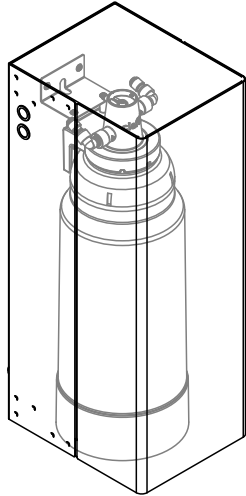
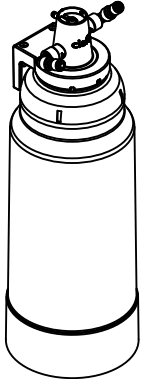
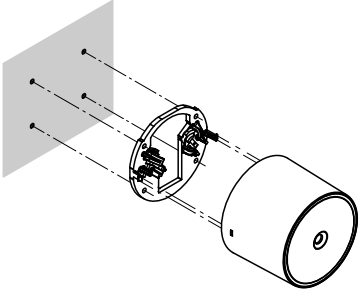
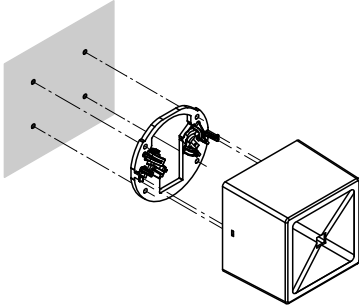

Fig. 9: Spray circuit overview

Maximum spray circuit length

The maximum spray circuit length depends on the water supply pressure on the central unit (see [Section 4.4](#)).

3.5 Options

<p>Second water filter in housing</p> 	<p>Second water filter to prolong the interval between filter replacements.</p>
<p>Water filter without housing</p> 	<p>Water filter without housing for placing on the ground. Serves as an alternative to the first and/or second water filter if there is no room to attach the water filter in the housing at the installation site.</p>
<p>Round surface panel</p> 	<p>If flush mounting is not possible, the humidifier units can be installed using the optional panel (round or square).</p>
<p>Square surface panel</p> 	

Reverse osmosis system RO-HB

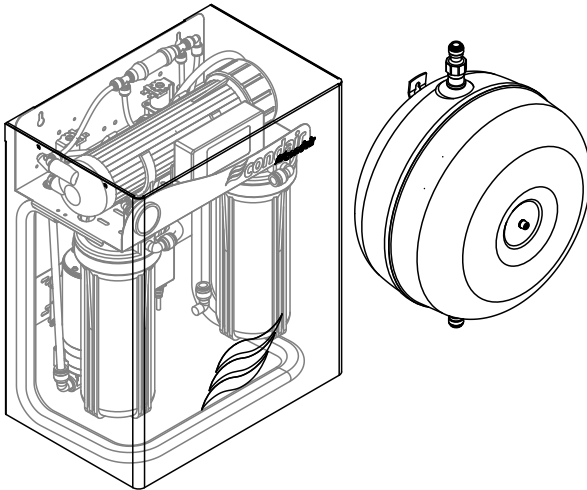

Reverse osmosis system RO-HB consisting of the reverse osmosis unit Condair RO-H and the 12 l flow tank for feeding the central unit with RO water. Note: A booster module is additionally required to operate the Condair MN system with the RO-HB reverse osmosis system.

Booster modules for reverse osmosis system RO-HB

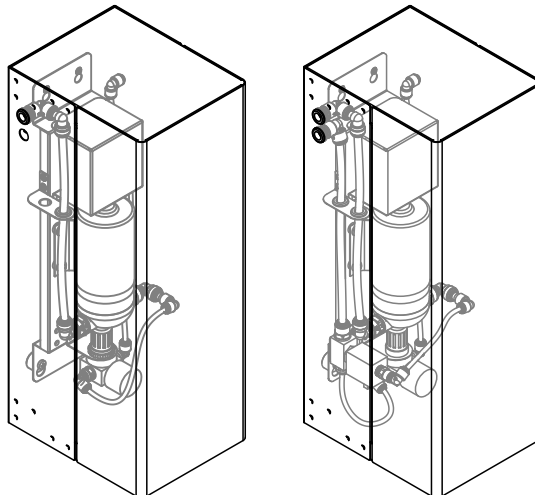

Booster modules for the RO-HB reverse osmosis system. The booster modules are available in a version for single systems (to feed one central unit) and a version for multiple systems (to feed up to 3 central units). In the case of multiple systems, one booster module is required per central unit.

4 Planning a Condair MN system

4.1 Note on the water supply to the Condair MN

The Condair MN can be operated with raw water (drinking water) or with RO water from the reverse osmosis system Condair RO-HB.

For larger systems or systems with a high number of operating days and/or with a high number of operating hours per day, the use of the reverse osmosis system RO-HB for the treatment of the supply water must be considered. Please contact your Condair representative to determine when the use of the reverse osmosis system RO-HB is worthwhile.

4.2 Determining the number of humidifier units

The following information and documents are required to calculate the humidity requirement and/or the number of humidifier units:

- Desired humidity and room temperature (target values)
- Absolute humidity of outside air or relative humidity in %rh and temperature of outside air
- Room volume for humidifying per room (calculated from room area x room height)
- Air change rate or air quantity per hour
- Floor plan, side and front elevations of the room to be humidified, including the room dimensions and scale

4.3 Configuring the central unit

The following information is required for the configuration of the central unit:

- Number of water filters (1 or 2):

Establishing whether the central unit must be equipped with one or two water filter(s) depends on the water quality of the inlet water and the number of humidifier units in the system and is established based on the following table.

Water quality	Number of humidifier units	Number of water filters
< 25 ppm (< 1.46 gpg)	< 8	1
< 25 ppm (< 1.46 gpg)	≥ 8	2
≥ 25 ppm (≥ 1.46 gpg)	< 5	1
≥ 25 ppm (≥ 1.46 gpg)	≥ 5	2
≥ 40 ppm (≥ 2.34 gpg)	Independent	2

- Number of spray circuits (1 or 2):

The number of spray circuits depends on the maximum spray circuit length (see [Section 4.4](#)) and the maximum number of humidifier units per spray circuit (max. 10 humidifier units per spray circuit).

Example 1: At a water supply pressure of 43.5 psig (300 kPa) and a spray circuit length of 328 ft (100 m), the humidifier units must be distributed between two spray circuits with a maximum length of 197 ft (60 m).

Example 2: With a total of 14 humidifier units required, these must be distributed between two spray circuits (max. 10 humidifier units per spray circuit).

4.4 Calculating cable and hose lengths

The maximum length of the cables and hoses required can be calculated based on the positioning of the humidifier units (see [Section 4.7](#)). The maximum length per spray circuit depends on the water supply pressure.

Water supply pressure	Maximum spray circuit length per spray circuit
43.5 psig (300 kPa)	up to 197 ft (60 m)
50.8 psig (350 kPa)	up to 262 ft (80 m)
58.0 psig (400 kPa)	up to 328 ft (100 m)
65.3 psig (450 kPa)	up to 361 ft (110 m)
72.5 psig (500 kPa)	up to 394 ft (120 m)

4.5 Information on positioning the central unit and water filter(s)

The central unit and the water filter(s) should be installed in a lockable technical room with limited access for people where possible. The room must meet the following requirements:

- The room temperature should be between +45°F (+7°C) and +77°F (+25°C) all year round and the room should be ventilated.

Important: If the central unit is installed in a cupboard, it must be ensured that it is sufficiently aired or equipped with a ventilation system (provided on site).

- There must be a sufficiently large free wall space to install the central unit and the water filter(s) (see [Fig. 10](#)).

Important: The wall that the central unit and the water filter(s) will be installed on must have a sufficient load-bearing capacity (see weight information in [Fig. 10](#)) and be suitable for the attachment.

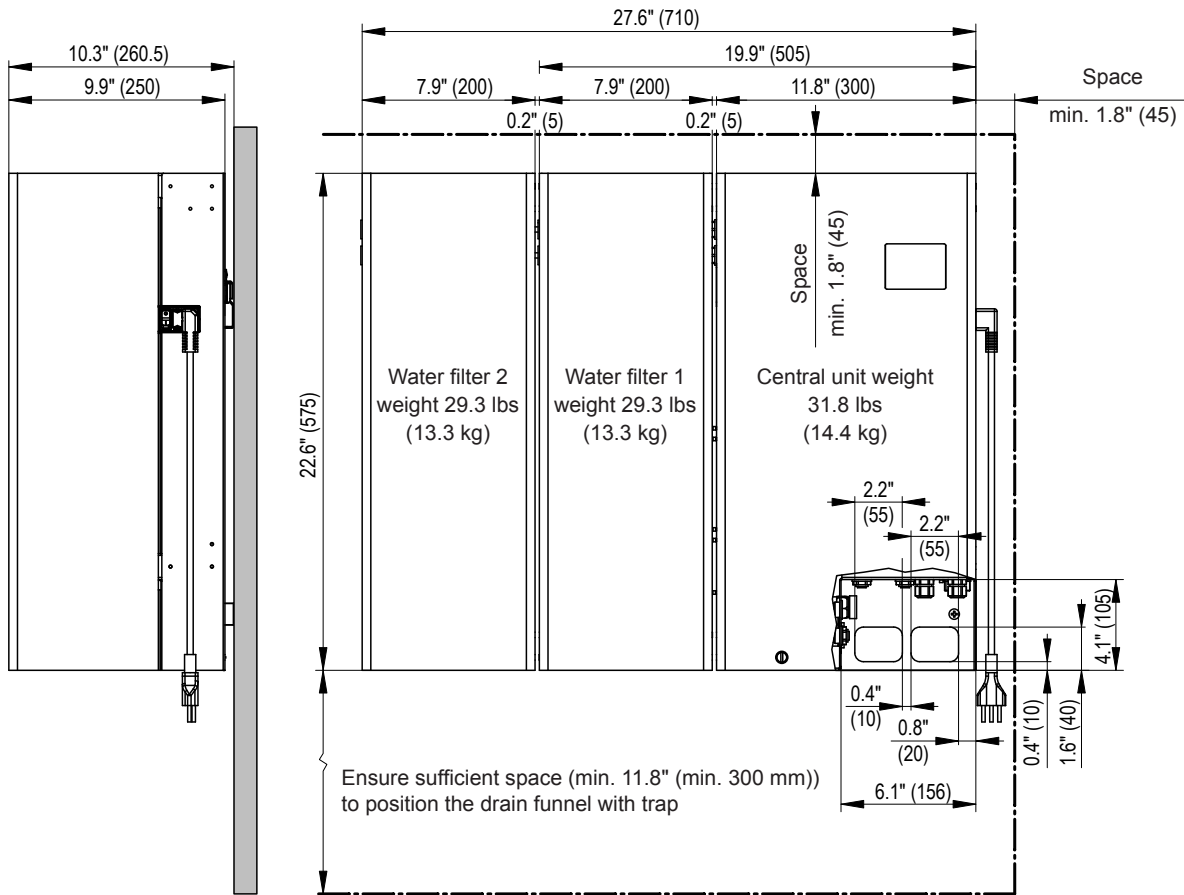

Fig. 10: Central unit and water filter dimensions (dimensions in inch (mm))

- In the area immediately surrounding the place where the central unit is being installed:
 - There must be at least **two 3-pin wall sockets (L1, N and Ground) with a mains power supply of 115 VAC / 60 Hz.**
 - There must be a **3/4"** drinking water tap with a shut-off valve and a backflow preventer for fluid category 2 (provided on site).
- There must be an **open drain funnel with trap** connected to the building's wastewater pipe underneath the central unit.
- We recommend positioning the central unit in a room with a floor drain connected to the building's wastewater pipe.
- There must be a LAN connection (Wi-Fi only available by request) in direct proximity to the central unit.

4.6 Information on positioning of the components of the optional reverse osmosis system Condair RO-HB

The components of the optional RO-HB reverse osmosis system (RO-H reverse osmosis unit, 3 gal (12 l) flow tank and booster module) should, if possible, be installed in the same lockable technical room near the central unit. The room must meet the following requirements:

- The room temperature should be between +45°F (+7°C) and +77°F (+25°C) all year round and the room should be ventilated.
- There must be a sufficiently large free wall space in the room for the installation of the RO-H reverse osmosis unit, the flow tank and the booster module(s) (see [Fig. 11](#) to [Fig. 17](#)).

Important: The wall on which the components of the reverse osmosis system are mounted must have sufficient load-bearing capacity (see weight information in [Fig. 11](#)) and be suitable for the attachment.

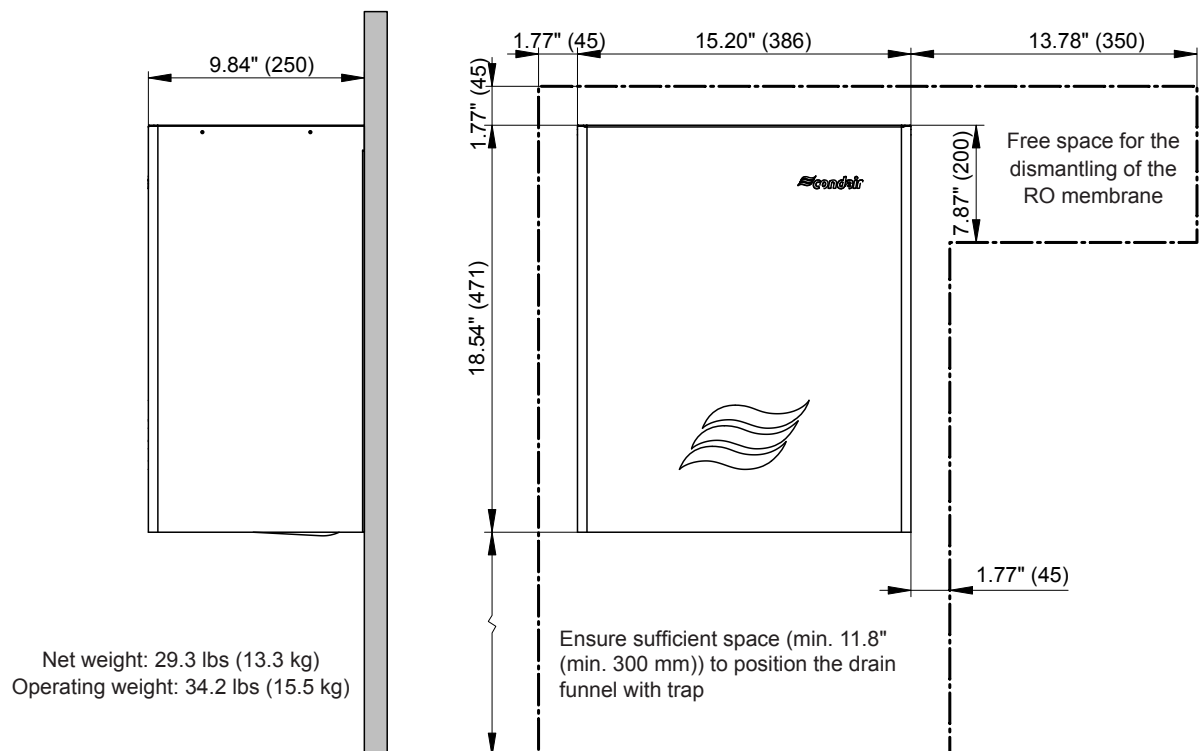

Fig. 11: Dimensions RO-H (dimensions in inch (mm))

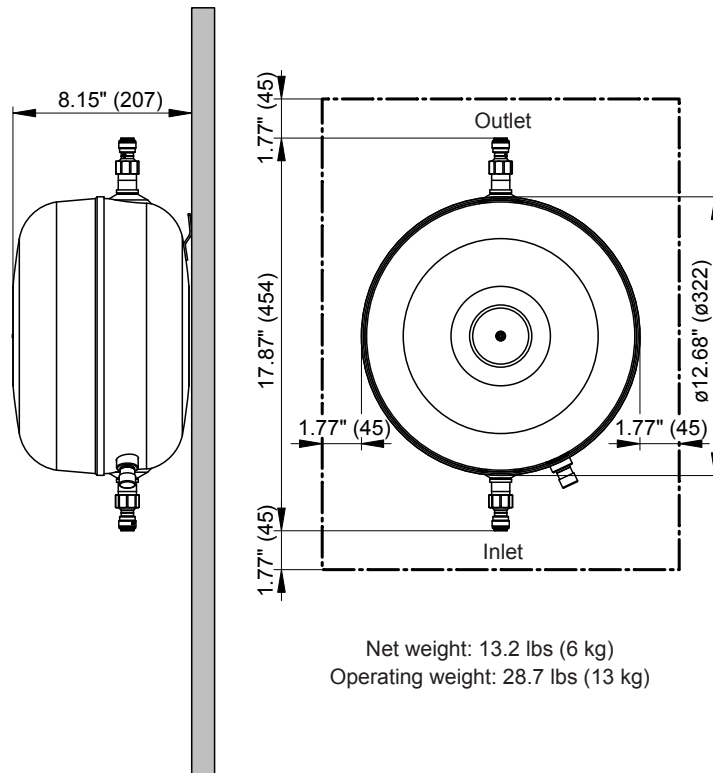

Fig. 12: Dimensions flow tank (dimensions in inch (mm))

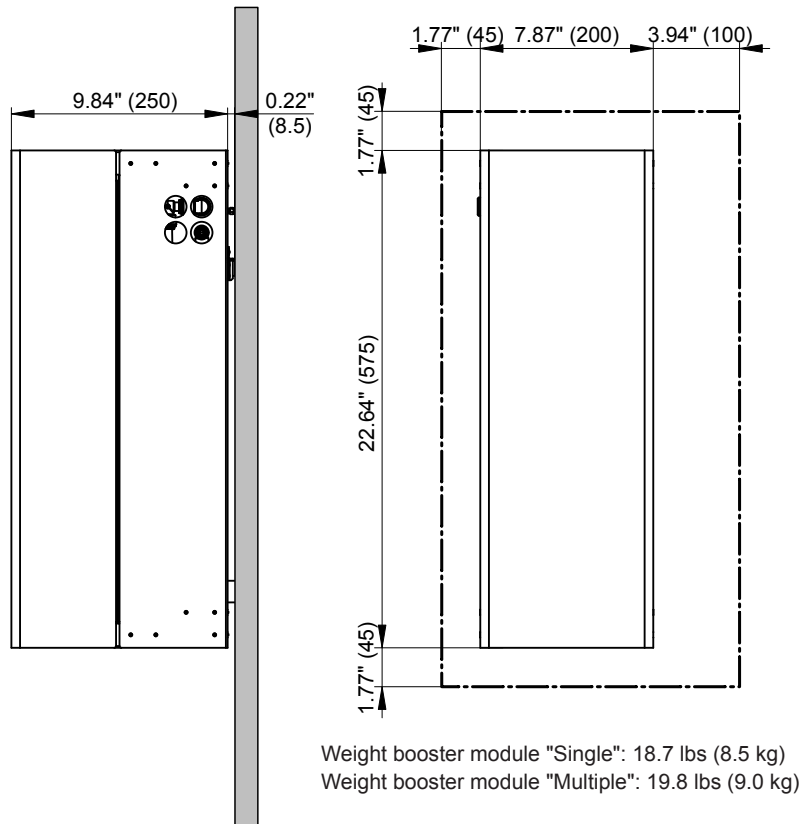

Fig. 13: Dimensions booster module (dimensions in inch (mm))

- In the immediate vicinity of the installation site of the RO-HB reverse osmosis system:
 - There must be at least **two 3-pin wall sockets (L1, N and PE) with a mains power supply of 115 VAC / 60 Hz.**
 - There must be a drinking water connection for the supply of the reverse osmosis unit Condair RO-H (for details see installation and operation manual for the Condair RO-H).
- If the water drain of the Condair RO-H reverse osmosis unit cannot be routed into the drain funnel of the central unit of the Condair MN, an **open drain funnel** with trap must be available below the reverse osmosis unit Condair RO-H, which is connected to the building's wastewater pipe.
- We recommend positioning the RO-HB reverse osmosis system in a room with a floor drain that is connected to the building's waste water pipe.
- The booster module(s) must be positioned in such a way that the **maximum hose length of 65.6 ft (20 m) between the outlet connection on the flow tank and the inlet connection on the booster module is not exceeded.**
- If possible, the RO-HB reverse osmosis system, the booster module(s) as well as the central unit(s) and the water filter(s) of the Condair MN should be placed on the same floor. If this is not possible in your specific case, please contact your Condair representative.

The components of the reverse osmosis system can be placed individually. However, it is important to ensure that:

- the components are easily accessible for installation and maintenance.
- the clearances of the individual components are observed.
- the hose lengths are kept as short as possible and the hoses can be routed correctly.
- the control cable(s) connected to the booster module(s) has/have a length of 3 m. The booster module(s) must therefore not be installed more than 1 m away from the corresponding central unit.

Possible placement variants with the corresponding minimum distances are shown below.

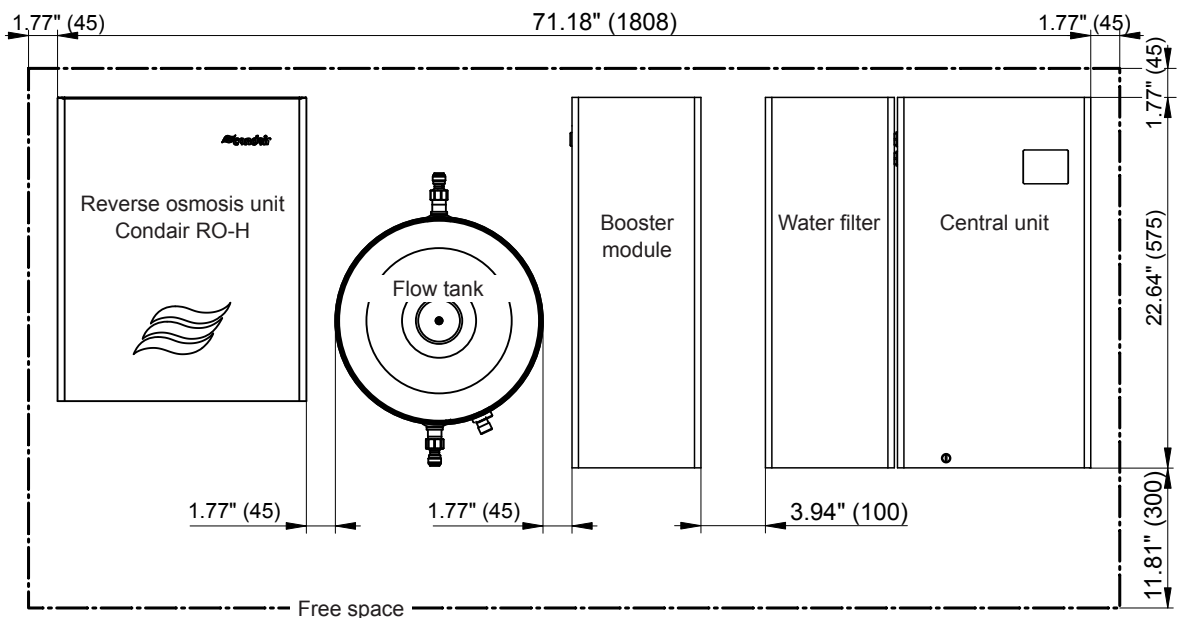
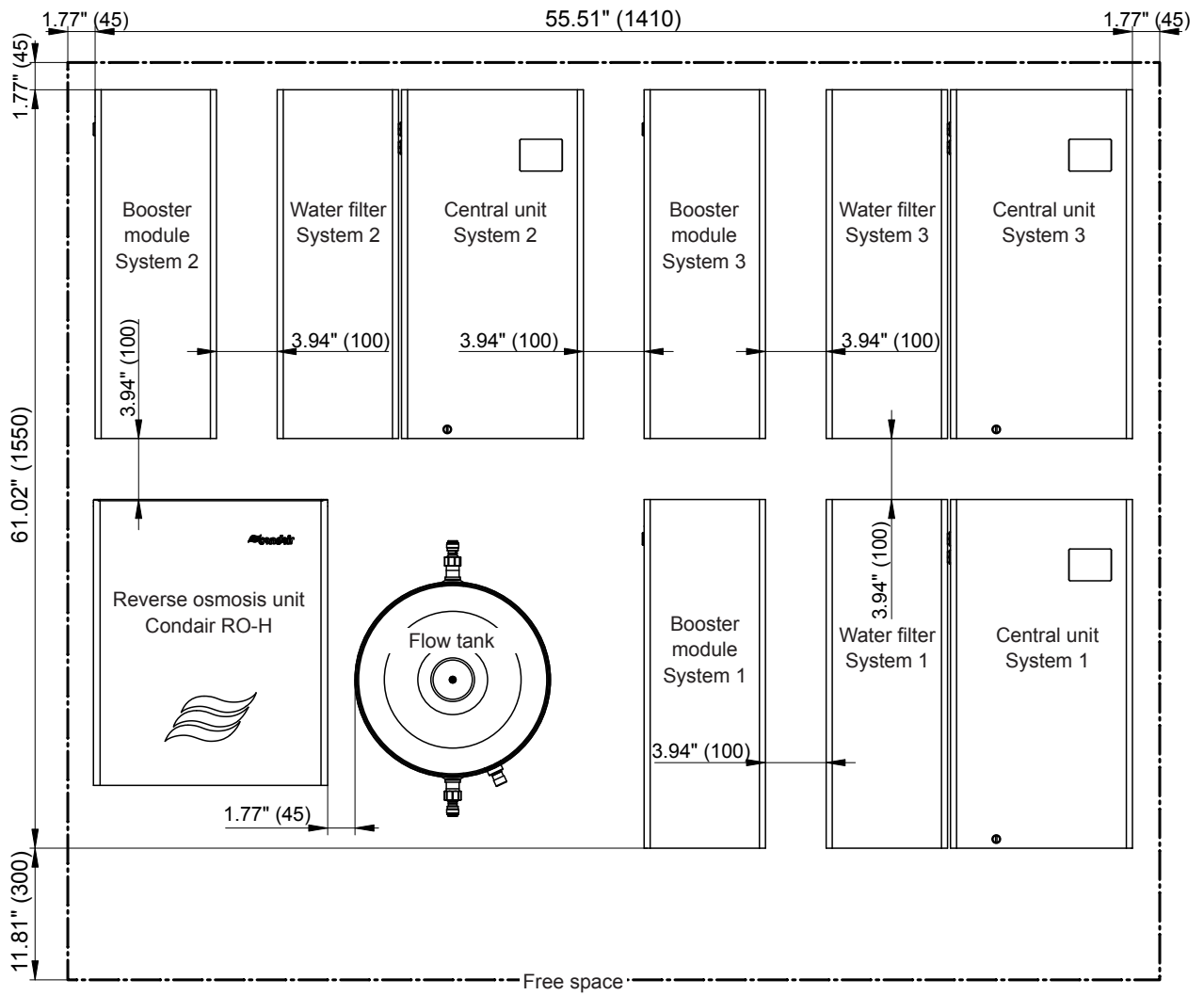

Fig. 14: Placement example 1 single system (dimensions in inch (mm))



Important note: In the case of multiple systems, only MN systems with one water filter can be used or connected!

Fig. 17: Placement example multiple system (dimensions in inch (mm))

4.7 Positioning the humidifier units

When positioning the humidifier units, the following specifications must be referred to and complied with. Under all circumstances, the requirements for the installation site of humidifier units in accordance with VDI 6022, sheet 6 must be met:

- The humidifier units must be positioned so that the mist can spread freely in the room and is not facing obstacles, such as pillars, furniture, cold outer walls, window surfaces, etc. where the humid air could condense. The required minimum distances are stated below and can be viewed in the [Fig. 18](#).

Important: The specified minimum distances refer to a room humidity of 45 %rh. If the room humidity is higher, the minimum distances increase accordingly.

A	Min. horizontal distance from obstacles in humidifier unit wall installation 39.4" (1.0 m)
B	Min. distance of surface-installed humidifier units from the ceiling 3.9" (0.1 m)
C	Min. space "C" beneath the humidifier unit 59.1" (1.5 m)
D	Min. distance "D" from windows in humidifier unit ceiling installation 39.4" (1.0 m)
E	Min. distance "E" from walls in humidifier unit ceiling installation 19.7" (0.5 m)

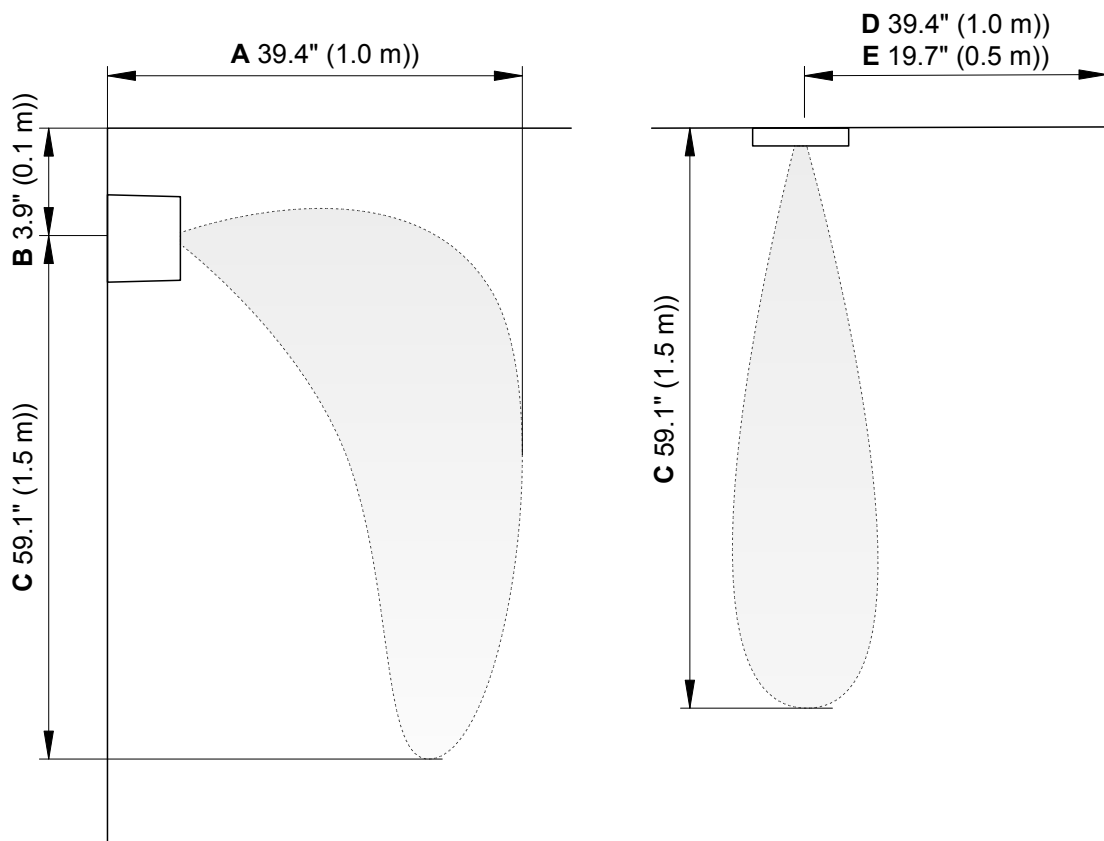

Fig. 18: Required minimum distances in the positioning of humidifier units

- The humidifier units may not be placed in niches, enclosed corridors, behind curtains, etc. as these positions do not guarantee optimum distribution of humidity.
- Humidifier units should ideally be positioned in walkways. However, it must be ensured that people are not negatively impacted by the cooling of the room air during atomization.

- When positioning the humidifier units, the air flow within the room must be taken into account. Do not position humidifier units directly near air outlets.
- The humidifier units should not be placed in rooms where increased air pollution can be expected, particularly from micro-organisms and allergens.
- The humidifier units' sound emissions are below 25 dB(A). The humidifier units can therefore also be placed in quiet zones.

4.8 Water supply requirements

4.8.1 Water supply requirements (without RO system)

- The supply water must meet the following requirements:

Water quality	Drinking in accordance with applicable local drinking water regulations
Permissible water temperature	41 ... 77 °F (5 ... 25 °C)
Permissible water hardness	50...530 ppm (2.92 ... 30.99 gpg)
Permissible conductivity	5 ...1000 µS/cm
Permissible water pressure	43.5 ... 72.5 psig

Note: The inlet water's quality compliance must be examined before connecting the feed line to the central unit.

- The water inlet must be installed in accordance with the DIN EN 1717 and DIN 1988-100 standards, the SVGW & DVGW directives and local drinking water regulations.
- A stop valve (provided on site) must be installed in the feed line just before the central unit.
- For water pressures above >14.5 psig (>500 kPa), a pressure reduction valve must be built into the feed line (adjusted to 14.5 psig (500 kPa) (provided on site).
- At room temperatures >77°F (>25°C), the water supply line must be insulated, as a high water supply temperature leads to increased temperature flushings and thus increased water consumption.

4.8.2 Water supply requirements for the reverse osmosis system Condair RO-HB

Information on the water supply of the reverse osmosis system Condair RO-HB can be found in the separate installation and operation manual for the Condair RO-H.

4.9 Water outlet requirements

There must be an open drain funnel with trap connected to the building's wastewater pipe directly underneath the central unit.

Note: For peripheral drainage of the spray circuits, there must be an open drain funnel with trap at each drainage place.

The outlet pipe must not touch the drain funnel and must be 0.8" (2 cm) away from the drain funnel.



During drainage, there is a pressure surge in the central unit's outlet pipe (central drainage) or the drain module (peripheral drainage). The outlet pipe must therefore be fixed so that it cannot slip out of the drain funnel and is not touching the drain funnel.

Note: If the water drain of the optional reverse osmosis unit Condair RO-H cannot be routed into the drain funnel of the central unit, an additional drain funnel with trap must be provided in the room.

4.10 Power supply requirements

To connect the central unit (connecting cable length: **80" (2 m)**) and the LAN gateway (connecting cable length: **40" (1 m)**) to the power supply, **two three-pin wall sockets (L1, N and Ground) with a mains voltage of 115 VAC / 60 Hz** must be installed in direct proximity to both units. Both wall sockets must be installed and secured in accordance with the locally applicable regulations for electrical installations.

To operate the Condair MN with the optional Condair RO-HB reverse osmosis system, **two additional three-pin wall sockets (L1, N and Ground) with a mains voltage of 115 VAC / 60 Hz** must be installed in direct proximity of the Condair RO-H reverse osmosis unit (connecting cable length: **40" (2 m)**) and the booster module (connecting cable length: **40" (2 m)**). Both wall sockets must be installed and secured in accordance with the locally applicable regulations for electrical installations.

4.11 LAN connection requirements

The LAN connection is used to establish connection for the remote operation of the system via the web-based user application and for the remote maintenance of the system by an authorized Condair service technician.

For the central unit's LAN connection, there must be an Ethernet connection in direct proximity to the central unit where possible.

The system's network must meet the following requirements:

- IP addresses must be assigned automatically (DHCP).
- The following outgoing ports must be accessible via the internet: 80 (http), 443 (https), 22 (ssh).
- Connection to the network should, wherever possible, be made via cable. As the systems are often installed in unoccupied spaces, it is very possible that the signal strength is not sufficient in the case of a wireless connection.
- For a wireless connection, it must be ensured that the WiFi of the internet router of the building network is activated and accessible.
- SSID and password are required for protected networks.
- The connection to the LAN must be guaranteed.

4.12 Information on servicing the Condair MN

To ensure hygienic operation the Condair MD system must be serviced by authorized service specialists once a year.

The service is regulated in a corresponding service contract. Condair arranges and carries out the annual service. After completion, the service must be documented in the customer's service log.

Note: For the maintenance of the optional reverse osmosis system Condair RO-HB, please refer to the information in the separate installation and operating manual for the Condair RO-H.

4.13 Delivery scope overview

All material not supplied by Condair must be arranged by the installer according to the conditions on site.

Material	Condair delivery scope	Provided on site
Central unit		
– Central unit with water filter(s)	X	
– Mains power cable (3-pin) with plug	X	
– Feed line from room connection to central unit (3/4" connection)		X
– Drain funnel with trap		X
– Double mains power socket		X
– LAN connection		X
Humidifier units		
– Humidifier units	X	
– Cable connector terminals	X	
– Flush-mounting boxes including lid for concrete (for specifications, see Section 6.5)		X
Installation material		
– Material for attaching flush-mounting installation boxes, central unit, etc.		X
– 4-wire bus cable	X	
– Hoses 0.24" (6 mm) in diameter	X	
– Guide pipes for flush mounting (for specifications, see Section 6.5)		X
– LAN cable		X

Scope of delivery Booster module for the reverse osmosis system Condair RO-HB

Material	Condair delivery scope	Provided on site
Booster module for the supply of single systems or booster modules for the supply of multiple systems including connection cable	X	
Water hose ø10 mm	X	

Scope of delivery optional reverse osmosis system Condair RO-HB

See installation and operating manual for the Condair RO-H.

5 Preparatory installations

5.1 Checking delivery / Storage and transport

5.1.1 Checking delivery

Following receipt of the delivery:

- Check the packaging for damage.
Any damage must be immediately reported to the transport company.
- Use the delivery note to check whether all components have been delivered.
Report missing components to your Condair partner.
- Remove the components from their packaging and check them for any damage. Notify the transport company immediately should you find any damaged parts/components.

5.1.2 Storage and transport

Storage

The Condair MN components must be stored in the original packaging in a place secured against dripping water under the following conditions until installation:

- Room temperature: 41 ... 104°F (5 ... 40°C)
- Room humidity: 10 ... 75%rh (non-condensing)

Transport

Where possible, always transport the components in the original packaging and use a suitable means of transport or suitable lifting device where necessary.



WARNING!

The customer is responsible for ensuring that staff are trained on handling heavy goods and are aware of and adhere to the relevant provisions on occupational safety and accident prevention.

Packaging

Keep the original packaging for later use.

If the packaging should be disposed of, follow local environmental protection guidelines. Recycle the packaging material wherever possible.

5.2 Tools required for installation

The following tools are required to install the Condair MN:

- Standard electrical installation tools:
 - Pliers
 - Wire strippers (e.g. Weidmüller Stripex)
 - Crimping pliers (e.g. Knipex 975314)
 - Slot and Philips screwdrivers
 - Wire insertion tool
- Core drill $\varnothing 2.95''$ ($\varnothing 75$ mm) (flush-mounting) / $\varnothing 2.36''$ ($\varnothing 60$ mm) (surface-mounting) for installing humidifier units
- Drill
- John Guest hose cutter
- John Guest hose connector release tool

5.3 Preparatory installations overview

The preparatory installations must be carried out by the electrician and plumber and consist of the following tasks:

Step	Task	Responsible
1	Discussing the electrical plan with the installers	Designers
2	<p>Carrying out preparatory installations.</p> <ul style="list-style-type: none"> • Preparatory installations for flush-mounting humidifier units in new buildings with concrete ceilings: <ul style="list-style-type: none"> • Install installation boxes for installing the humidifier units (see Section 5.4.1). • Laying guide pipes (with a feeding-in cord/wire) in accordance with the electrical plan to the installation boxes, the central unit and, if laid out as such, to the peripheral drain module(s) (see Section 5.4.2). • Drilling holes $\varnothing 2.95''$ ($\varnothing 75$ mm) in the installation boxes (see Section 5.4.3). • Preparatory installations for flush-mounting humidifier units in suspended ceilings: <ul style="list-style-type: none"> • Drilling holes $\varnothing 2.95''$ ($\varnothing 75$ mm) at the installation points in the suspended ceiling (see Section 5.5.1). • If intended as such, laying guide pipes (with feed-in cord/wire) according to the electrical plan to the installation points of the humidifier units, the central unit and, if laid out as such, the peripheral drain module(s) (see Section 5.5.2). • Preparatory installations for surface-mounting humidifier units: <ul style="list-style-type: none"> • If planned, drill wall ducts 2.36'' (60 mm) in diameter into the wall at the installation points (see Section 5.6.1). • Lay cable ducts according to the electrical plan to the installation boards, the central unit and, if designed as such, the peripheral drain module(s) (see Section 5.6.2). • Install mains power sockets for the mains power supply to the central unit and the LAN connection. • Set up LAN installation. 	Electricians

3	<p>Set up plumbing installations.</p> <ul style="list-style-type: none"> • Install the central unit and water filter(s) in the planned location (see Section 5.7). • If applicable: Mount components of the optional reverse osmosis system Condair RO-HB at the intended location (see Section 5.8) • Install the drain funnel with trap beneath the central unit and, if designed as such, beneath the peripheral drain module(s) and connect to the building wastewater pipe (see Section 5.9.2). • Set up feed line to the central unit (connection G 3/4") including shut-off valve and backflow preventer (see Section 5.9.2). • Feed in hoses and CAN bus cable (see Section 5.9.4). 	Plumber
4	Check execution of the preparatory installations and plumbing installations	Condair

5.4 Preparatory installations for flush-mounting humidifier units in new buildings with concrete ceilings

5.4.1 Install installation boxes for flush-mounting in concrete ceilings

For flush-mounting humidifier units in concrete ceilings in new buildings or suspended insulated ceilings, the installation boxes must be installed at the intended humidifier unit installation points.

5.4.1.1 Flush-mounting installation boxes for concrete ceilings

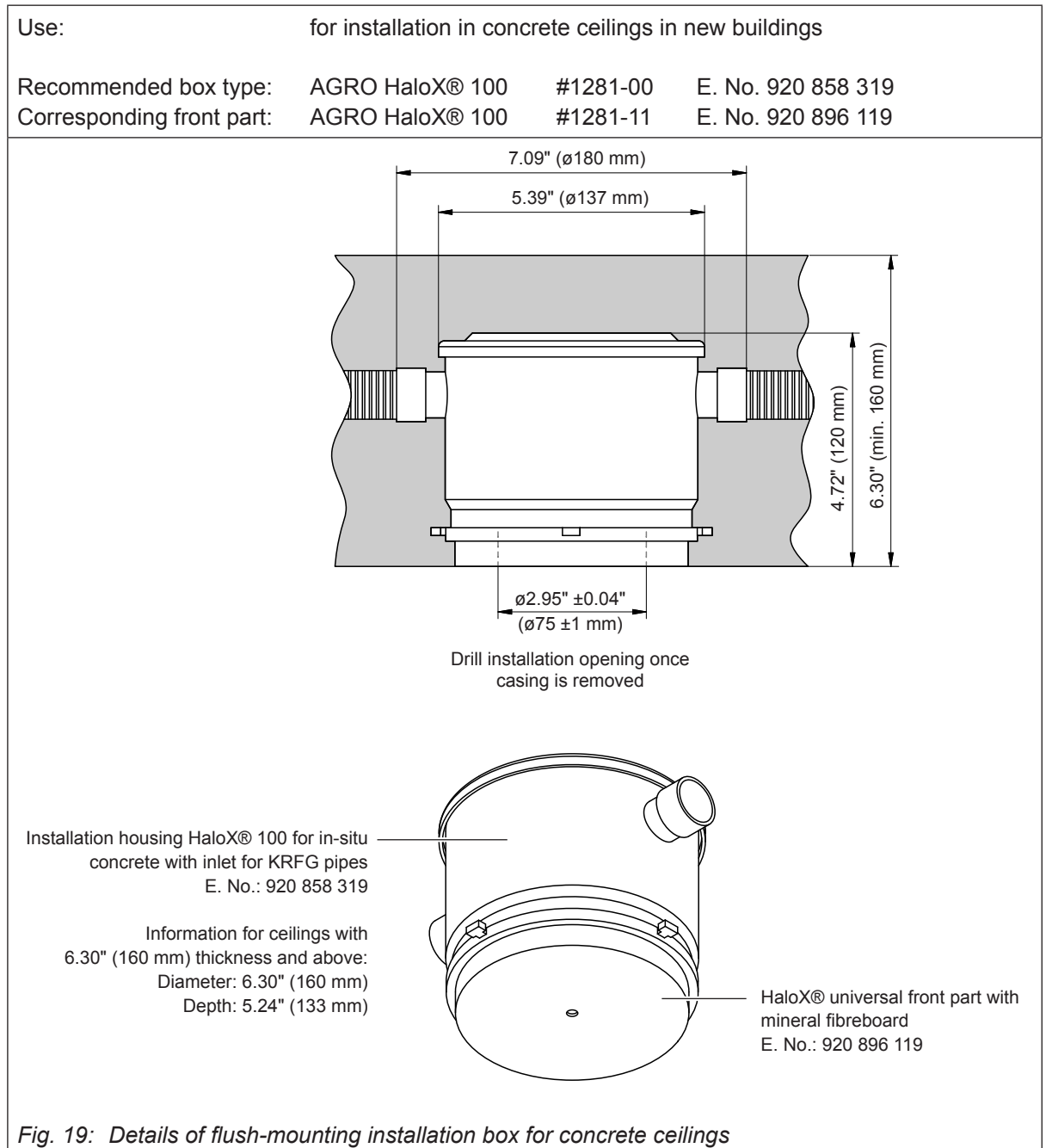

- The installation boxes for concrete ceilings must be placed in the intended locations on the shell and attached to the casing.

5.4.2 Laying the guide pipes

Lead a guide pipe (with feed-in cord/wire) into and away from each flush-mounting installation box and/or to each installation point. The plan sets out the sequence in which the individual flush-mounting installation boxes and/or installation points should be connected with guide pipes.

The guide pipe running away from the last installation box and/or installation point for each spray circuit leads either back to the central unit (central spray circuit drainage) or the drain module (peripheral spray circuit drainage).

- For concrete ceilings, the guide pipes must be placed in both of the entries intended for them in the installation boxes and attached (see [Fig. 19](#)) so as to ensure that they cannot slip out when the concrete is inserted.

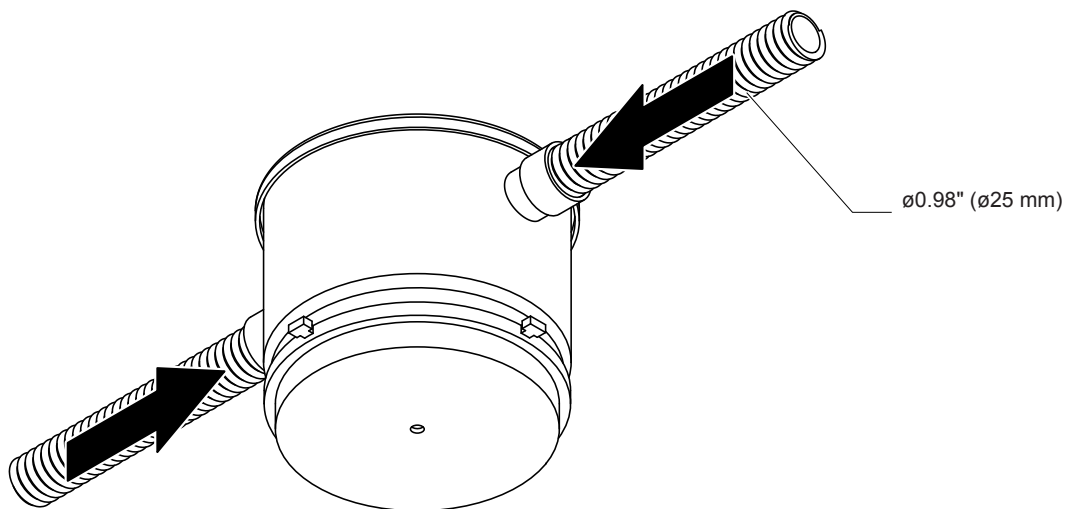
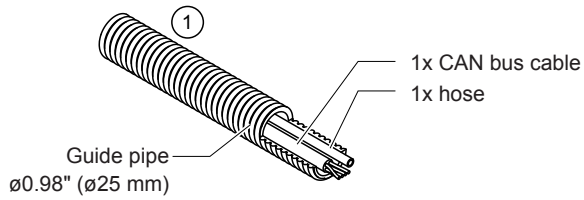
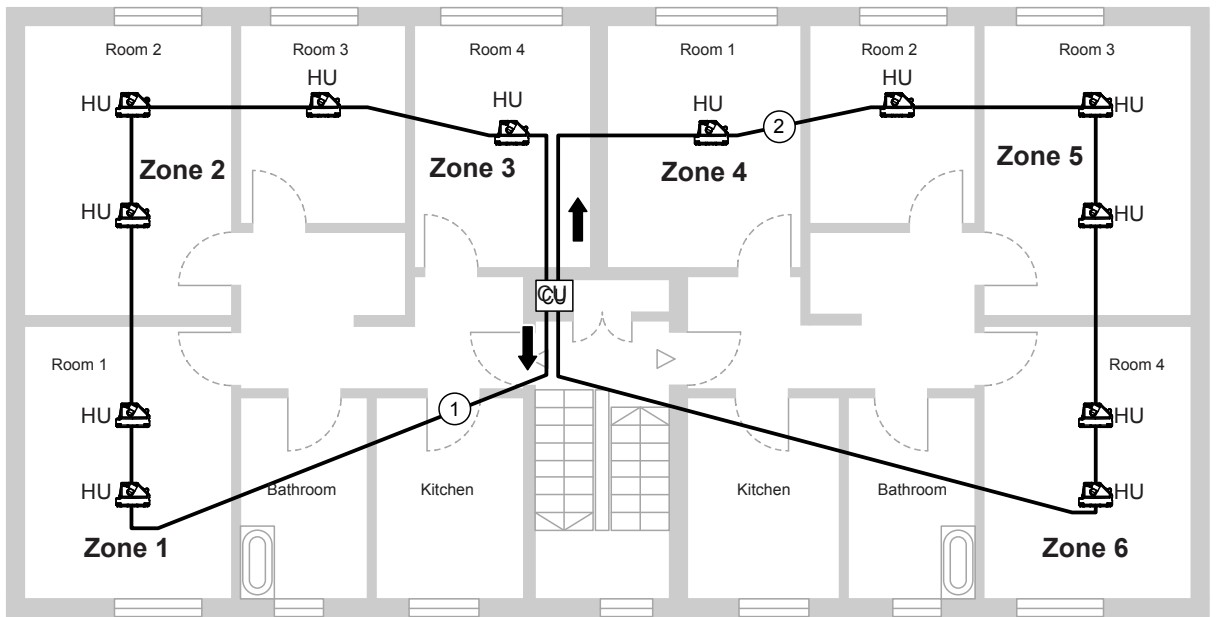

Fig. 20: Details of flush-mounting installation box for concrete ceilings

Important: When laying the guide tubes, make sure that they are laid with the largest possible radii so that the hoses and CAN bus cables can be easily pulled in. **Under no circumstances should the guide tubes be kinked.**

The applicable specifications on laying guide pipes must be followed and complied with. The following illustrations show possible guide pipe designs for central and peripheral spray circuit drainage.



- | | | | |
|---|---|----|---------------------------------|
| 1 | Spray circuit 1 with central spray circuit drainage | CU | Central unit with drain modules |
| 2 | Spray circuit 2 with central spray circuit drainage | HU | Humidifier unit |

Fig. 21: Guide pipe layout with central spray circuit drainage (1 and 2)

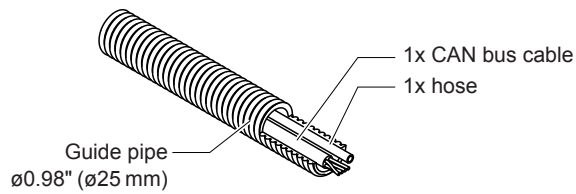
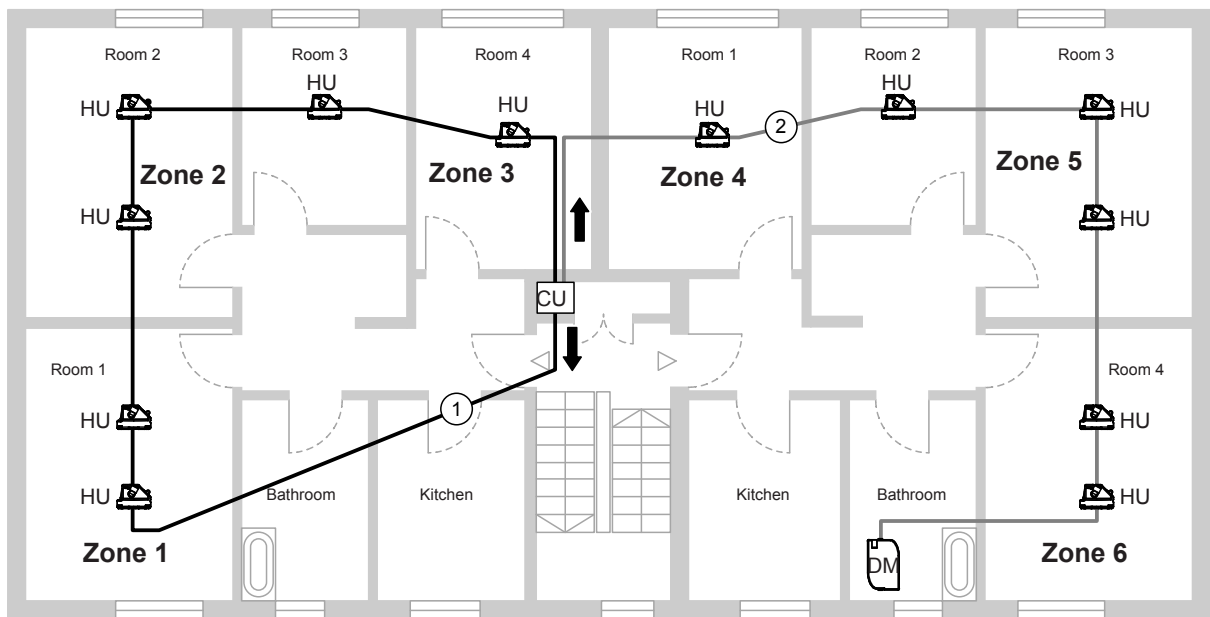

- | | | | |
|---|--|----|------------------------------------|
| 1 | Spray circuit 1 with central spray circuit drainage | CU | Central unit |
| 2 | Spray circuit 2 with peripheral spray circuit drainage | HU | Humidifier unit |
| | | DM | Drain module (peripheral drainage) |

Fig. 22: Guide pipe layout with central (1) and peripheral (2) spray circuit drainage

5.4.3 Drilling installation openings in the installation boxes

- Once the casings are removed, the installation openings $\varnothing 2.95''$ ($\varnothing 75$ mm) must be drilled in the lid of the installation boxes.

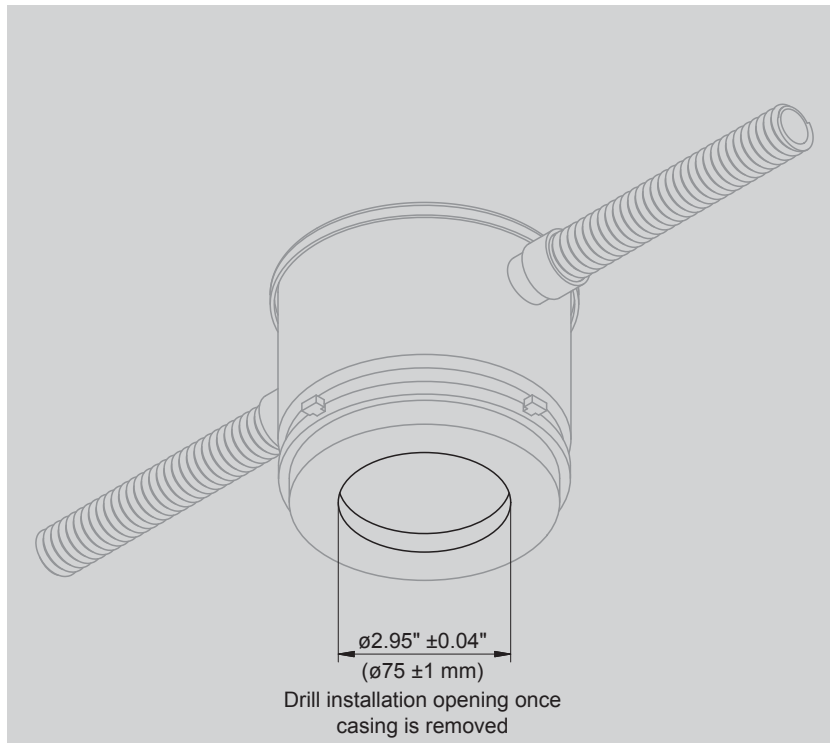

Fig. 23: Drill installation hole in the installation box

5.5 Preparatory installations for flush-mounting humidifier units in suspended ceilings

5.5.1 Drill installation openings in the suspended ceilings

- Drill installation openings $\varnothing 2.95''$ ($\varnothing 75$ mm) in the planned positions on the suspended ceilings.

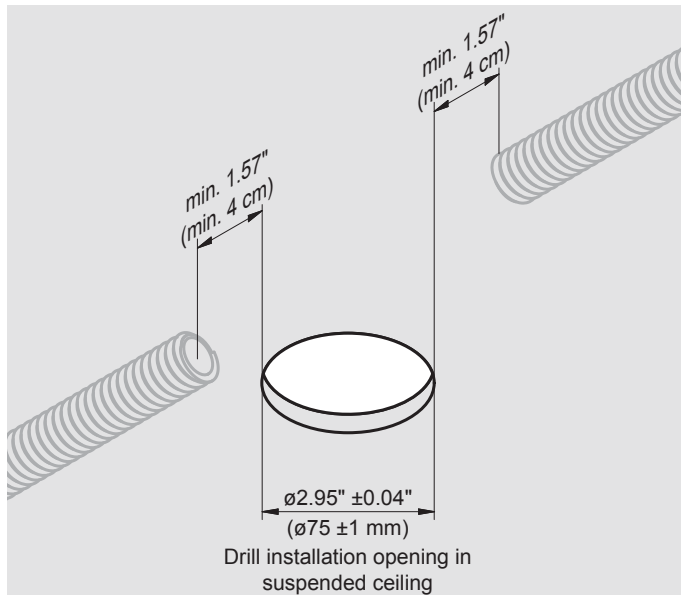

Fig. 24: Drill installation opening in the suspended ceilings

5.5.2 Laying the guide pipes

If guide pipes are laid to the installation points of the humidifier units in the case of suspended ceilings, we recommend using **guide pipes with $\varnothing 32$ mm**. For laying the guide tubes, please observe the instructions in [Section 5.4.2](#).

CAUTION!

The guide pipes may only extend to the installation hole (distance from end of pipe to installation hole min. $1.57''$ (min. 4 cm)). The guide pipes may not be led out of the installation opening.

5.6 Preparatory installations for surface-mounting humidifier units

5.6.1 Drill wall duct(s)

If the hoses and CAN bus cable should be led through the wall during surface mounting, a wall duct 60 mm in diameter must be drilled into the intended installation point(s).

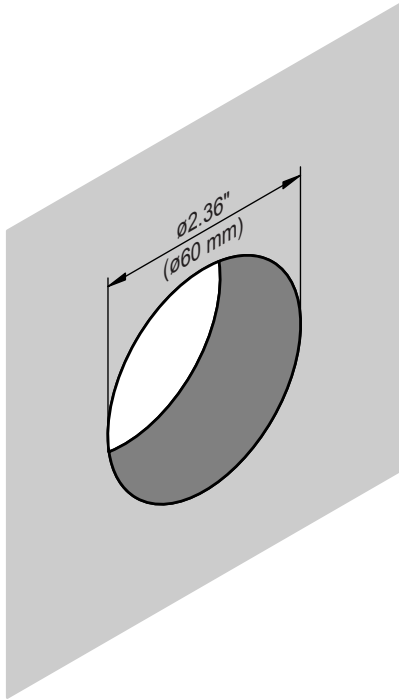

Fig. 25: Drill wall duct(s)

5.6.2 Laying cable ducts

Laying cable ducts depends on the cable duct used. In all cases, the cable duct must be selected so that a CAN bus cable and a hose can be led in and out of every surface mounting box.

A cable duct must feed into and away from every installation point on the humidifier unit. The plan sets out the sequence in which the individual surface-mounting boxes should be connected with cable ducts and this is plotted on the electrical plan.

The cable duct running away from the last surface mounting box for each spray circuit leads either back to the central unit (central spray circuit drainage) or the drain module (peripheral spray circuit drainage).

The same specifications apply to the layout of the cable duct as for the layout of the guide pipes. Please see in the information in [Section 5.4.2](#).

The applicable specifications on laying cable ducts must be followed and complied with.

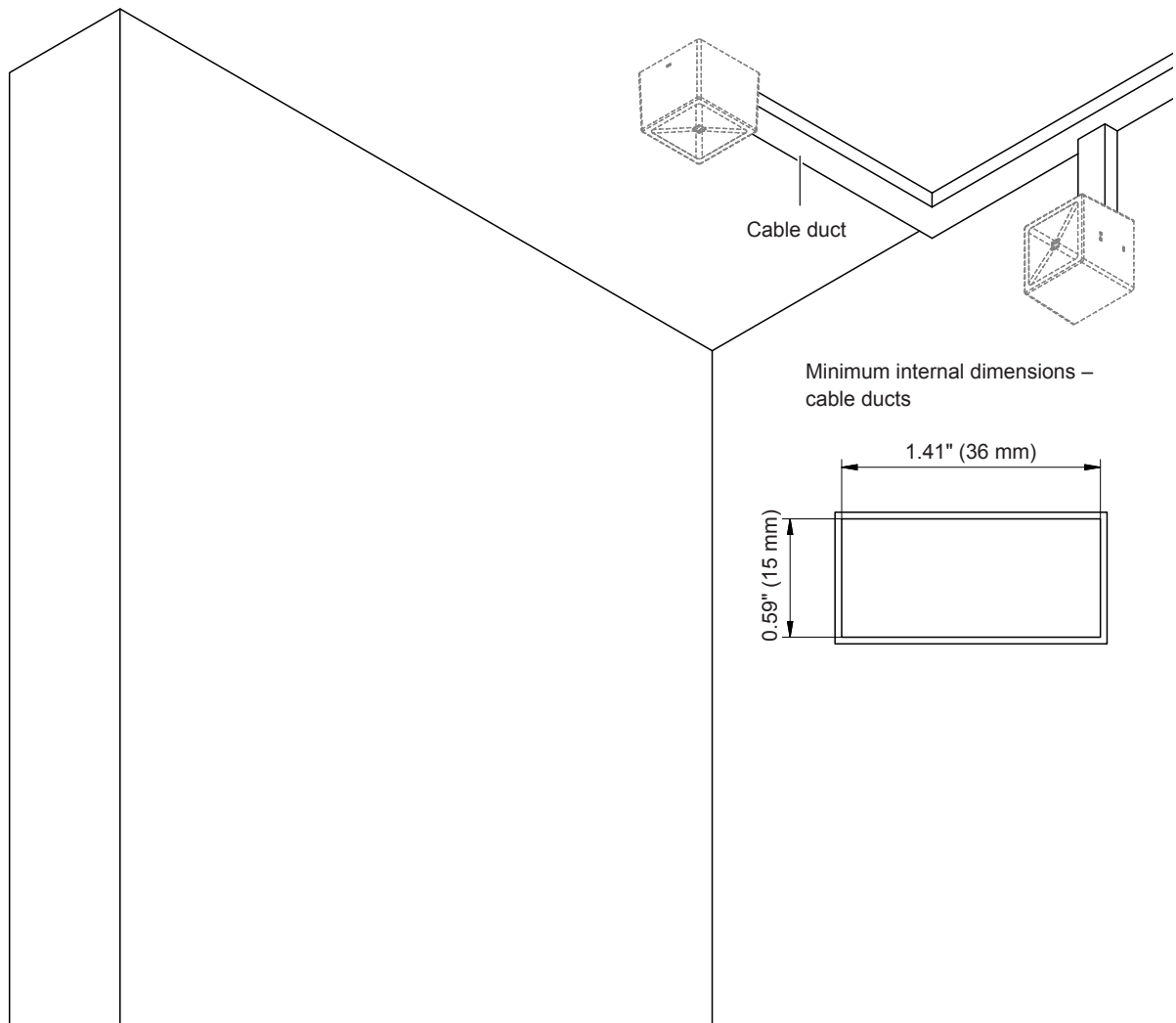

Fig. 26: Laying cable ducts

5.7 Installing the central unit and water filter(s) in the housing

Installation overview

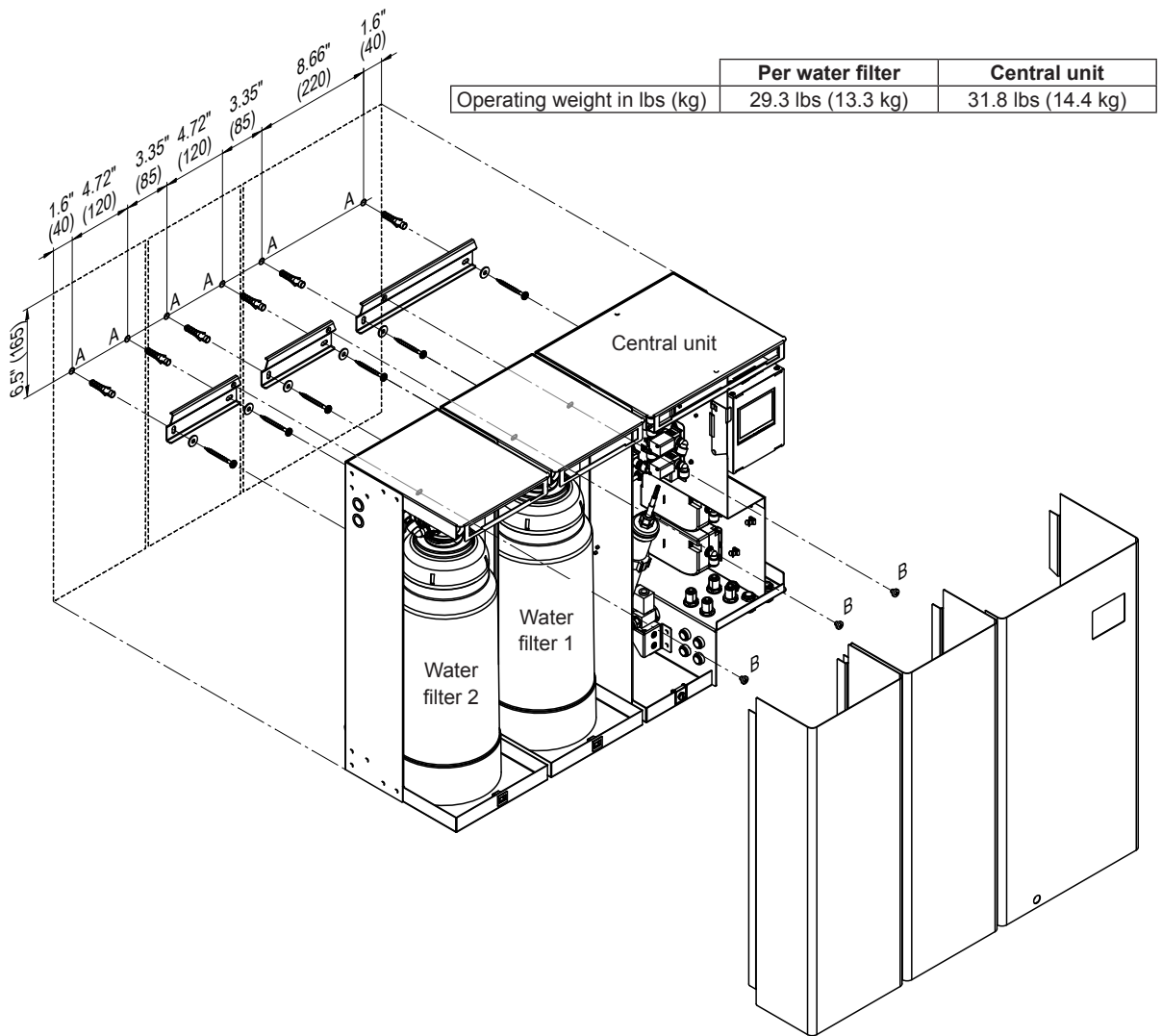

Fig. 27: Central unit installation overview (illustration shows installation with screws and dowels)

CAUTION!

The information on positioning the central unit in [Section 4.5](#) must be referred to and complied with.

Mounting procedure

1. Mark the attachment points "A" for the attachment rails at the desired position using a spirit level.
2. Fasten the attachment rails to the wall with 2-inch screws into 2 x 4 wood studs (or equivalent). Before tightening the screws, align the attachment rails horizontally using a spirit level.
3. Remove the front covers.
4. Hang the devices in the relevant attachment rails and fix to the attachment rails through the rear wall of the casing using the supplied screws "B".
5. Relocate the front covers and secure the front cover of the central unit with the screw.

Note: If, after mounting the central unit, the type plate attached to the right-hand side of the central unit is no longer or only insufficiently visible, the additionally type plate must be attached to the central unit in a clearly visible position (for example on the front cover)!

5.8 Installing the components of the optional reverse osmosis system Condair RO-HB

Mounting the Condair RO-H and the flow tank

Mount the reverse osmosis unit Condair RO-H and flow tank at the desired location, observing the placement instructions (see [Section 4.6](#)) and the information in the separate installation and operating manual for the Condair RO-H.

Mounting the booster module

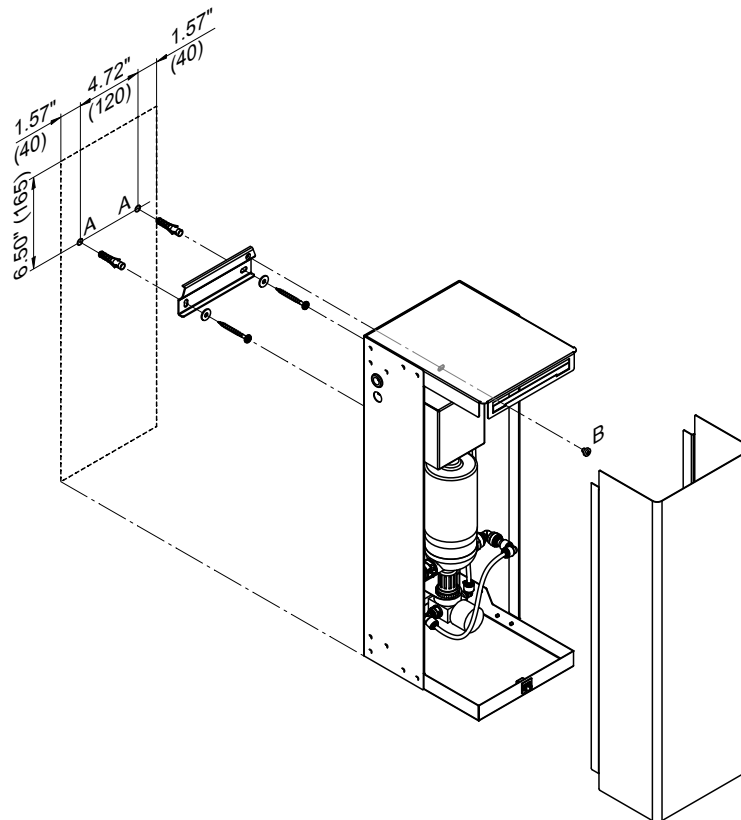

Fig. 28: Mounting the booster module

Mounting procedure

1. Mark the attachment points "A" for the attachment rail at the desired position using a spirit level.
2. Fasten the attachment rail to the wall using a suitable fastening material (provided on site) depending on the properties of the wall. Before tightening the screws, align the attachment rail horizontally using a spirit level.
3. Remove the front cover.
4. Hang the device in the attachment rail and fix to the attachment rail through the rear wall of the housing using the supplied screw "B".
5. Relocate the front cover.

5.9 Setting up water inlet and outlet

5.9.1 Information on water installation

Note: If the Condair MN is operated with the optional reverse osmosis system Condair RO-HB, please note the information on water installation in the separate installation and operating manual for the Condair RO-H.

Water inlet



The water inlet pipe may only be connected to the central unit upon commencing operation and after thorough flushing of the inlet pipe.

The water inlet must be installed in accordance with the DIN EN 1717 and DIN 1988-100 standards, the SVGW & DVGW directives and local drinking water regulations. The connection information stated must be complied with.

- A stop valve (3) and a backflow preventer for fluid category 2 (2) must be installed, where possible, in direct proximity to the central unit.
- We recommend installing a water stop hose in the feed line to the Condair MN central unit.
- So the disinfection kit can be connected during maintenance and periodic water samples can be taken from the inlet water, the last 19.7" (50 cm) of the water inlet pipe should be installed with a corresponding reinforced hose.
- For water pressures >14.5 psig (>500 kPa), a pressure reduction valve must be built into the inlet pipe which is set to 14.5 psig (500 kPa).
- The inlet water requirements must be complied with.

Water quality	Drinking in accordance with applicable local drinking water regulations
Permissible water temperature	41 ... 77 °F (5 ... 25 °C)
Permissible water hardness	50...530 ppm (2.92 ... 30.99 gpg)
Permissible conductivity	5 ... 1000 µS/cm
Permissible water pressure	43.5 ... 72.5 psig

- The connection material used must be pressure-tested and permitted for use in drinking water supply.
- Attach the inlet pipe using suitable resources.

Central unit water outlet

Set up the water outlet in accordance with the overview illustrations in [Section 5.9.2](#) and the applicable specifications for water installations. The connection information stated must be complied with.

- The maximum length of the outlet pipe, from device connection to drain funnel, should not exceed 6.56 ft (2 m). Longer outlet pipes are only permissible by agreement with Condair.
- Ensure that the outlet pipe, drain funnel and siphon are easily accessible and correctly attached for monitoring and cleaning purposes.
- Important: **The flushing process takes place under pressure. You must therefore attach the outlet pipe so that it cannot shift during operation (e.g. with angle support and drill).**
- The end of the outlet pipe must stop 0.8" (2 cm) above the drain funnel and may not touch it under any circumstances.
- Attach the drain funnel so that it cannot shift during operation.

5.9.2 Water installation overview

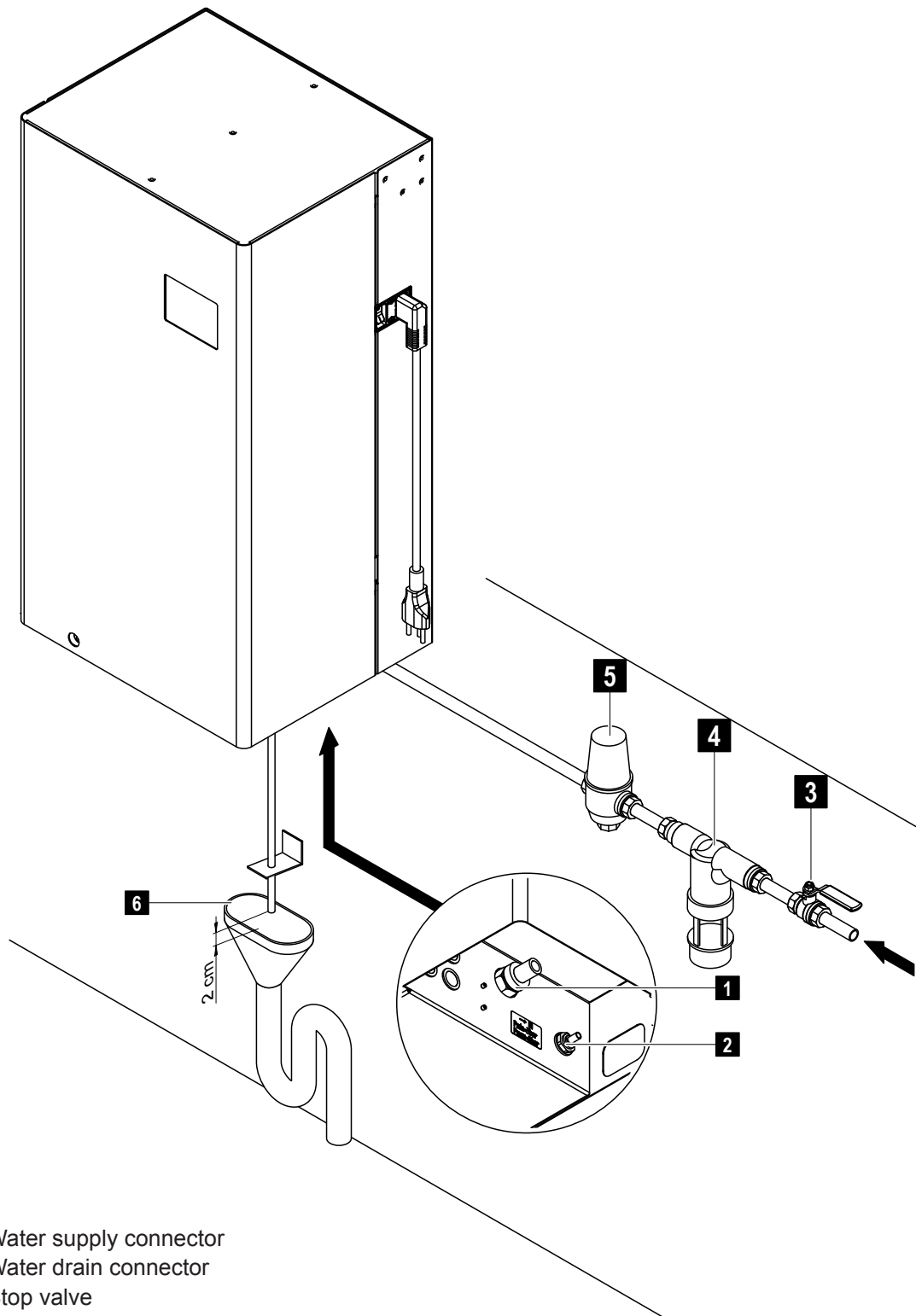

- 1 Water supply connector
- 2 Water drain connector
- 3 Stop valve
- 2 Backflow preventer for fluid category 2 with integrated particle filter (provided on site)
- 3 Pressure reduction valve for pressures >14.5 psig (>500 kPa)
- 4 Open drain funnel with syphon

Fig. 29: Water installation overview

5.9.3 Installing a drain funnel with trap for peripheral drain module(s)

Install the drain funnel with trap at the intended location. Attach the drain funnel so that it cannot shift during operation.

Note: The peripheral drain module(s) will be installed by the Condair service technician during commissioning.

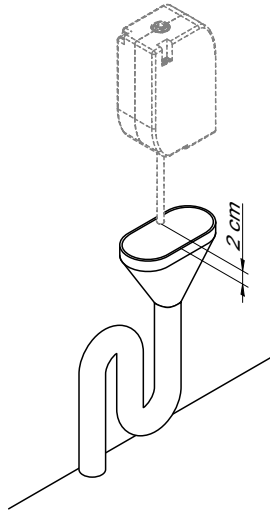

Fig. 30: Installing a drain funnel with trap for peripheral drain module(s)

5.9.4 Feeding in hoses and CAN bus cables



CAUTION! Risk of contamination

Before feeding in the hoses, the end of the hose must be sealed (e.g. with adhesive tape). Once the hoses are inserted, both ends of the hose must be sealed.

Important: The hoses and CAN bus cable for connection to the central unit must be labelled to avoid mixing them up (e.g. with spray circuit number and room that the hose/CAN bus cable leads to).

For central spray circuit drainage, according to the [Fig. 31](#), the CAN bus cables and the hoses must be inserted between the central unit and the humidifier units (guide pipe 0.98" (25 mm) in diameter or cable duct with a hose and CAN bus cable).

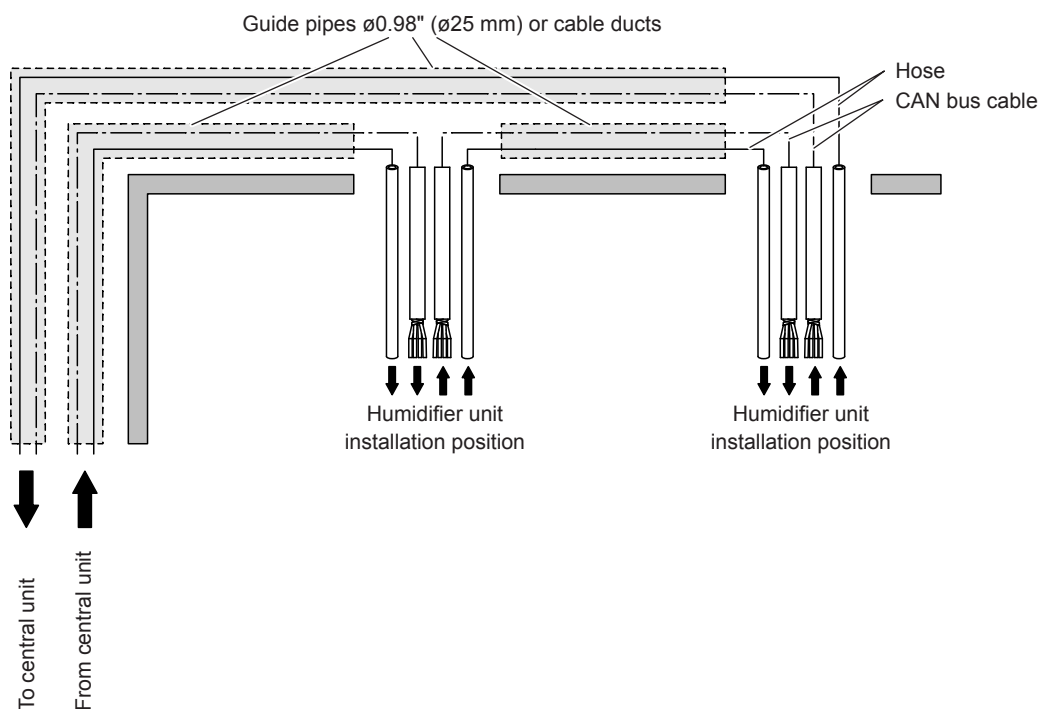

Fig. 31: CAN bus cable and hose guide for central spray circuit drain (with a hose and a CAN bus cable)

For peripheral spray circuit drainage, according to the [Fig. 32](#), the CAN bus cables and the hoses must be inserted between the central unit, the humidifier units and the drain module (guide pipe with a hose and CAN bus cable).

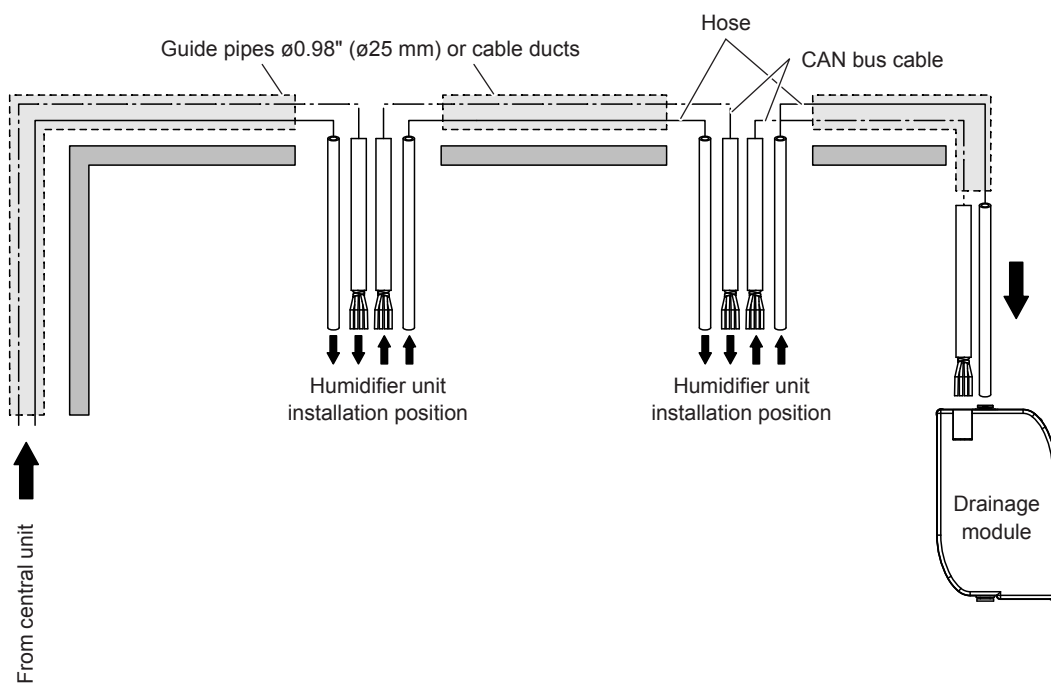

Fig. 32: CAN bus cable and hose guide for peripheral spray circuit drain

Information

- The hoses and CAN bus cables must be led a minimum of 11.81" (300 mm) from the ceiling or floor connection point before they are cut to length (see [Fig. 33](#)).

! **CAUTION!**
Risk of contamination

Once the hoses are inserted and cut to length, both ends of the hose must be sealed to prevent pollution (e.g. with adhesive tape).

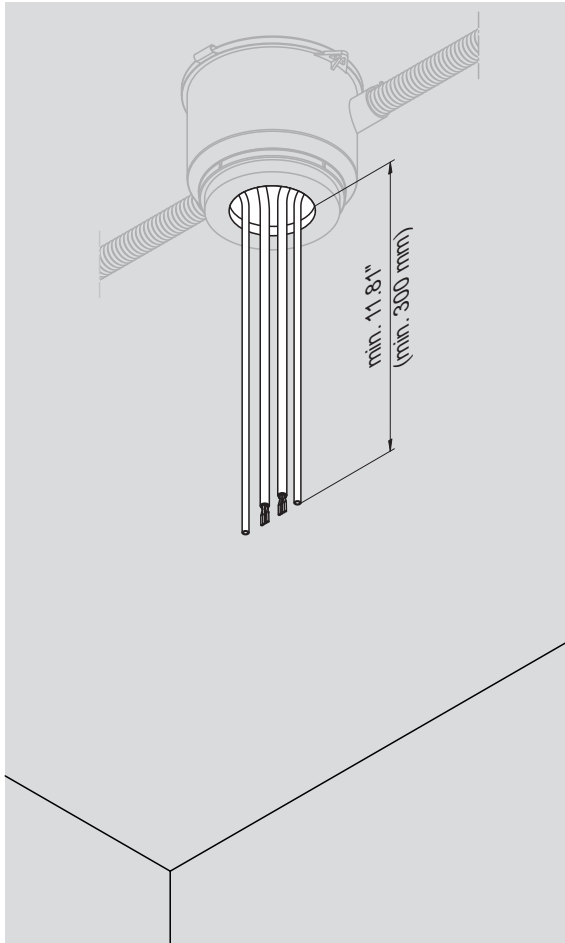

Fig. 33: Additional length for hoses and CAN bus cables

- For the central unit and external drain module, should there be one, the hoses and CAN bus cables must be cut to length leaving enough extra for easy connection (see [Fig. 33](#)).

6 Technical data

6.1 Central unit technical data

	1 water filter 1 spray circuit	1 water filter 2 spray circuits	2 water filter(s) 1 spray circuit	2 water filter(s) 2 spray circuits
Central unit water connection	3/4" NPT			
Flushing water quantities	Approx. 5.28 gallons/day (Approx. 20 litres/day)		Approx. 6.34 gallons/day (Approx. 24 litres/day)	
Minimum quality of inlet water	Drinking water according to applicable local drinking water specifications			
Permissible inlet water pressure	43.5 ... 72.5 psig (300 ... 500 kPa)			
Permissible inlet water temperature	41 ... 77 °F (5 ... 25 °C)			
Permissible inlet water conductivity	5 ... 1000 µS/cm			
Water treatment	Water filter (disposable mixed-bed resin cartridge), Optional reverse osmosis system Condair RO-HB			
UV lamp	For water sterilization			
Central unit electrical connection	Plug 115 VAC / 60 Hz			
Operating voltage	24 - 36 VDC			
Max. current draw	1.2 A	1.6 A	1.2 A	1.6 A
Max. power consumption	45 W	60 W	45 W	60 W
Housing	Galvanized sheet steel, powder-coated			
IP protection	IP 20			
Control, touchscreen	3 humidity levels plus humidity Off Operating status, cartridge replacement and fault indicator			
Mobile control	Condair WEB application			
Central unit dimensions H x W x D	19.88" x 22.64" x 9.84" (505 mm x 575 mm x 250 mm)		27.95" x 22.64" x 9.84" (710 mm x 575 mm x 250 mm)	
Minimum installation space required	21.65" x 24.60" x 10.63" (550 mm x 625 mm x 270 mm)		29.72" x 24.60" x 10.63" (755 mm x 625 mm x 270 mm)	
Central unit weight (in operation)	31.8 lbs (14.4 kg)			
Permissible ambient temperature	41 °F - 86 °F (5°C - 30 °C)			
Permissible ambient humidity	max. 80 %rh (not condensing)			

6.2 Humidifier unit technical data

Humidifying output (per humidifier unit)	1.272 gal/day or 10.58 lbs/day (±10%) (4.8 kg/Tag (±10%))
Nominal operating voltage	36 VDC
Nominal power consumption	30 mA
Sound pressure level	< 25 dB(A) (in accordance with SIA 181)
Permissible ambient temperature	41°F - 86°F (5°C - 30 °C)
Permissible ambient humidity	max. 80 %rh (not condensing)
Dimensions, flush-mounting	
Humidifier unit diameter	2.87" (73 mm)
Panel diameter	4.13" (105 mm)
Humidifier unit height (including panel)	2.05" (52 mm)
Min. installation depth	3.94" (100 mm)
Panel height	0.47" (12 mm)
Dimensions, "round" surface mounting	
Humidifier unit diameter	2.87" (73 mm)
Panel diameter	3.43" (87 mm)
Humidifier unit height (including panel)	2.68" (68 mm)
Dimensions, "square" surface mounting	
Humidifier unit diameter	2.87" (73 mm)
Panel dimensions	3.43" x 3.43" (87 x 87 mm)
Humidifier unit height (including panel)	2.76" (70 mm)

6.3 Hose technical data

Material	John Guest "PE-04025-0100M-N"
Diameter ID/OD	0.16"/0.24" (4/6 mm)

6.4 CAN bus cable technical data

Type	2x2 twisted pair
Diameter OD	0.31" (8 mm)
Line impedance	120 ohms

6.5 Flush-mounting installation box/guide pipes technical data

Installation box (for concrete installations)	AGRO HaloX® 100 / #1281-00 / E. No. 920 858 319
Installation box lid (for concrete installations)	AGRO HaloX® 100 / #1281-11 / E. No. 920 896 119
Guide pipe	KRFG pipe 0.98" (25 mm) in diameter Note: When running the guide pipe through a ceiling plenum or any air plenum, electric metallic (EMT) conduit is the required guide pipe material.

6.6 Technical data optional reverse osmosis system Condair RO-HB

See separate installation and operating manual for the Condair RO-H.

Warranty

Condair Inc. and/or Condair Ltd. (hereinafter collectively referred to as THE COMPANY), warrant for a period of two years after installation or 30 months from manufacturer's ship date, whichever date is earlier, that THE COMPANY's manufactured and assembled products, not otherwise expressly warranted, are free from defects in material and workmanship. No warranty is made against corrosion, deterioration, or suitability of substituted materials used as a result of compliance with government regulations.

THE COMPANY's obligations and liabilities under this warranty are limited to furnishing replacement parts to the customer, F.O.B. THE COMPANY's factory, providing the defective part(s) is returned freight prepaid by the customer. Parts used for repairs are warranted for the balance of the term of the warranty on the original humidifier or 90 days, whichever is longer.

The warranties set forth herein are in lieu of all other warranties expressed or implied by law. No liability whatsoever shall be attached to THE COMPANY until said products have been paid for in full and then said liability shall be limited to the original purchase price for the product. Any further warranty must be in writing, signed by an officer of THE COMPANY.

THE COMPANY's parts or materials that are considered consumables, including but not limited to: cylinders, filters, nozzles, membranes, media, gaskets, O-rings, etc. are NOT covered by the warranty.

THE COMPANY makes no warranty and assumes no liability unless the equipment is installed in strict accordance with a copy of the catalog and installation manual in effect at the date of purchase and by a contractor approved by THE COMPANY to install such equipment.

THE COMPANY makes no warranty and assumes no liability whatsoever for consequential damage or damage resulting directly from misapplication, incorrect sizing or lack of proper maintenance of the equipment.

THE COMPANY makes no warranty and assumes no liability whatsoever for damage resulting from freezing of the humidifier, supply lines, drain lines, or quality of the water used.

THE COMPANY retains the right to change the design, specification and performance criteria of its products without notice or obligation.

THE COMPANY's limited warranty on accessories, not of the companies manufacture, such as controls, humidistats, pumps, etc. is limited to the warranty of the original equipment manufacturer from date of original shipment of humidifier.



U.S.A.
835 Commerce Park Drive
Ogdensburg, New York 13669

CANADA
2740 Fenton Road
Ottawa, Ontario K1T 3T7

TEL: 1.866.667.8321
FAX: 613.822.7964

EMAIL: na.humilife@condair.com
WEBSITE: www.condairhumilife.com

