

READ AND SAVE THESE INSTRUCTIONS

INSTALLATION MANUAL

Adiabatic air humidification system
Condair DL II

Thank you for choosing Condair

Installation date (MM/DD/YYYY):

Commissioning date (MM/DD/YYYY):

Site:

Model:

Serial number:

Fill in data at the commissioning!

Contact

Condair Ltd.
2740 Fenton Road, Ottawa, Ontario K1T3T7
TEL: 1.866.667.8321, FAX: 613.822.7964
EMAIL: na.info@condair.com, WEBSITE: www.condair.com

Proprietary Notice

This document and the information disclosed herein are proprietary data of Condair Ltd. Neither this document, nor the information contained herein shall be reproduced, used, or disclosed to others without the written authorization of Condair Ltd., except to the extent required for installation or maintenance of recipient's equipment.

Liability Notice

Condair Ltd. does not accept any liability due to incorrect installation or operation of the equipment or due to the use of parts/components/equipment that are not authorized by Condair Ltd.

Copyright Notice

© Condair Ltd., All rights reserved.

Technical modifications reserved

Contents

1	Introduction	4
1.1	General	4
1.2	Notes on the installation manual	4
2	For your safety	6
3	Important notes	8
3.1	Inspection of the delivery	8
3.2	Storing/Transportation/Packaging	8
3.3	Product designation	9
4	Mounting and installation work	10
4.1	Safety notes on mounting and installation work	10
4.2	Installation overview	11
4.3	Installation of the humidification unit	12
4.3.1	Positioning of the humidification unit	12
4.3.2	Mounting the post-evaporation unit	15
4.3.2.1	Overview frame constructions post-evaporation unit	15
4.3.2.2	Mounting procedure post-evaporation unit	16
4.3.3	Mounting the nozzle system	36
4.3.3.1	Overview frame constructions nozzle system	36
4.3.3.2	Mounting procedure nozzle system	37
4.4	Positioning and mounting the control unit and central unit mounting rack	46
4.5	Converting the spray circuit outlets from left to right	49
4.6	Mounting the central unit to the mounting rack	52
4.7	Mounting the control unit to the mounting rack	53
4.8	Water installation	54
4.8.1	Overview water installation	54
4.8.2	Notes on water installation	55
4.9	Electrical installation	57
4.9.1	Notes on electrical installation	57
4.9.2	Wiring diagram Condair DL	58
4.10	Wiring plan Condair DL	59
4.10.1	Electrical connections between central unit and control unit	60
4.10.1.1	Wiring diagram central unit - control unit	60
4.10.1.2	Installation work central unit - control unit	61
4.10.2	External electrical connections	65
4.10.2.1	Wiring diagram external electrical connections	65
4.10.2.2	Installation work external connections	66
4.10.3	Connecting options	68
5	Appendix	69
5.1	Dimensional drawing control unit	69
5.2	Dimensional drawing central unit	70

1 Introduction

1.1 General

We thank you for having purchased the **adiabatic air humidification system Condair DL**.

The humidification system Condair DL incorporates the latest technical advances and meets all recognized safety standards. Nevertheless, improper use of the humidification system Condair DL may result in danger to the user or third parties and/or impairment of material assets.

To ensure a safe, proper, and economical operation of the humidification system Condair DL, please observe and comply with all information and safety instructions contained in the present documentation as well as in the separate documentations of the components installed in the humidification system.

If you have questions after reading this documentation, please contact your Condair representative. They will be glad to assist you.

1.2 Notes on the installation manual

Limitation

The subject of this installation manual is the humidification system Condair DL in its different versions. The various options and accessories are only described insofar as is necessary for proper operation of the equipment. Further information on options and accessories can be obtained in the respective instructions.

This installation manual is restricted to the **installation** of the humidification system Condair DL and is meant for **well trained personnel being sufficiently qualified for their respective work**.

This installation manual is supplemented by various separate items of documentation (operation manual, spare parts list, etc.), which are included in the delivery as well. Where necessary, appropriate cross-references are made to these publications in the installation manual.

Symbols used in this manual



CAUTION!

The catchword "CAUTION" used in conjunction with the general caution symbol designates notes in this installation manual that, if neglected, may cause **damage and/or malfunction of the unit or other material assets**.



WARNING!

The catchword "WARNING" used in conjunction with the general caution symbol designates safety and danger notes in this installation manual that, if neglected, may cause **injury to persons**.



DANGER!

The catchword "DANGER" used in conjunction with the general caution symbol designates safety and danger notes in this installation manual that, if neglected, may lead to **severe injury or even death of persons**.

Safekeeping

Please safeguard this installation manual in a safe place, where it can be immediately accessed. If the equipment changes hands, the documentation must be passed on to the new operator.

If the documentation gets mislaid, please contact your Condair representative.

Language versions

This installation manual is available in various languages. Please contact your Condair representative for information.

2 For your safety

General

Every person working with the humidification system Condair DL must have read and understood this installation manual and the operation manual of the Condair DL before carrying out any work.

Knowing and understanding the contents of the installation manual and the operation manual is a basic requirement for protecting the personnel against any kind of danger, to prevent faulty operation, and to operate the unit safely and correctly.

All ideograms, signs and markings applied to the components of the humidification system Condair DL must be observed and kept in readable state.

Qualification of personnel

All installation work described in this installation manual **may only be carried out by specialists who are well trained and adequately qualified and are authorized by the customer.**

For safety and warranty reasons any action beyond the scope of this manual must be carried out only by qualified personnel authorized by the manufacturer.

It is assumed that all persons working with the humidification system Condair DL are familiar and comply with the appropriate regulations on work safety and the prevention of accidents.

Intended use

The humidification system Condair DL is intended exclusively for **air humidification in AHU's or air ducts** within the specified operating conditions (see operation manual of the humidification system Condair DL). Any other type of application, without the written consent of the manufacturer, is considered as not conforming with the intended purpose and may lead to the humidification system Condair DL becoming dangerous.

Operation of the equipment in the intended manner requires **that all the information contained in this installation manual are observed (in particular the safety instructions).**

Danger that may arise from the humidification system Condair DL



DANGER!
Danger of electric shock!

The control unit of the Condair DL and the pump motor inside the central unit (if applicable) are mains powered. Live parts may be exposed when the control unit and/or the central unit is/are open. Touching live parts may cause severe injury or danger to life.

Prevention: The control unit of the Condair DL must be connected to the mains only after all mounting and installation work has been completed, all installations have been checked for correct workmanship and all unit covers are relocated properly locked.

Important! The frequency converter in the control unit of systems with booster pump contains capacitors. These can remain charged with a potentially deadly voltage for a certain period of time after the control unit has been disconnected from the power supply. Therefore, wait at least 10 minutes after disconnecting the power supply. Then make sure the appropriate contacts on the frequency converter and the terminals on the pump motor are free of voltage before starting any work on these components!



WARNING!
Risk of injury

The ceramic plates of the post-evaporation unit are porous and have partial sharp edges. You may injure your hands on this sharp edges or may injure your eyes by splintering ceramic parts when handling the ceramic plates.

Prevention: when handling the ceramic plates always wear protecting gloves and goggles.

Preventing unsafe operation

All persons working with the humidification system Condair DL are obliged to report any alterations to the unit that may affect safety to the owner without delay and to **secure such systems against accidental power-up**.



CAUTION!

In order that the Condair DL does not remain in the error status unnoticed for a longer period of time in the event of a malfunction, errors must be signaled via a remote error indication (e.g. via the error relay of the remote operating and fault indication board or via the network via BACnet or Modbus).

Prohibited modifications to the unit

No modifications must be undertaken on the humidification system Condair DL without the express written consent of the manufacturer.

For the replacement of defective components use exclusively **original accessories and spare parts** available from your Condair representative.

3 Important notes

3.1 Inspection of the delivery

After receiving:

- Inspect shipping boxes for damage.
Any damages of the shipping boxes must be reported to the shipping company.
- Check packing slip to ensure all parts has been delivered.
All material shortages are to be reported to your Condair supplier within 48 hours after receipt of the goods. Condair assumes no responsibility for any material shortages beyond this period.
- Unpack the parts/components and check for any damage.
If parts/components are damaged, notify the shipping company immediately.
- Check whether the components are suitable for installation on your site according to the model key stated on the type plate (see [Section 3.3](#)).

3.2 Storing/Transportation/Packaging

Storing

Until installation store the system components in its original packaging in a protected area meeting the following requirements:

- Room temperature: 41...104 °F (5 ... 40 °C)
- Room humidity: 10 ... 75 %rh

Transportation

For optimum protection always transport the unit in the original packaging and use an appropriate lifting/transporting device.



WARNING!

It is the customer's responsibility to ensure that operators are trained in handling heavy goods and that the operators comply with the appropriate regulations on work safety and the prevention of accidents.

Packaging

Keep the original packaging of the components for later use.

In case you wish to dispose of the packaging, observe the local regulations on waste disposal. Please recycle packaging where possible.

3.3 Product designation

The product designation and the most important unit data are found on the rating plate fixed on the right side of the control unit and the central unit (see example below):

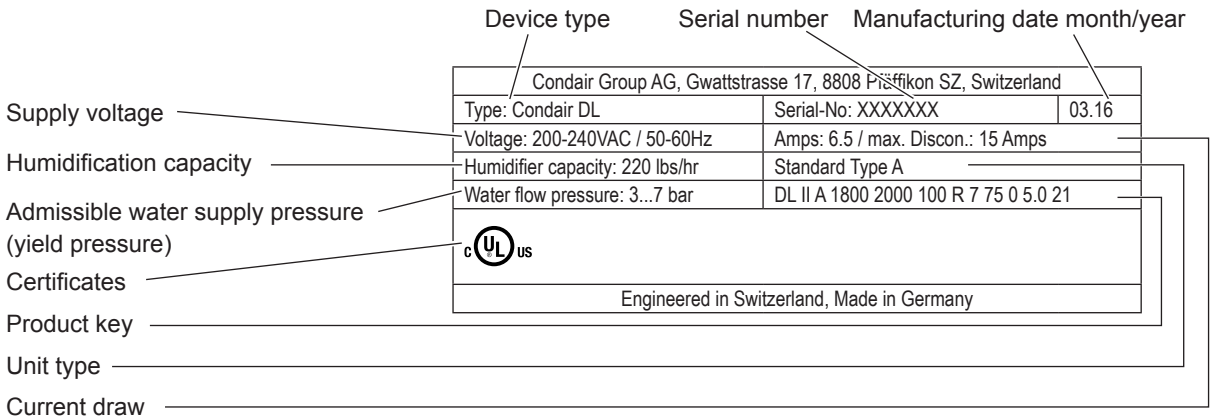

Product key

Example: **Condair DL II A 1800 2000 100 R 7 75 0 5.0 21**

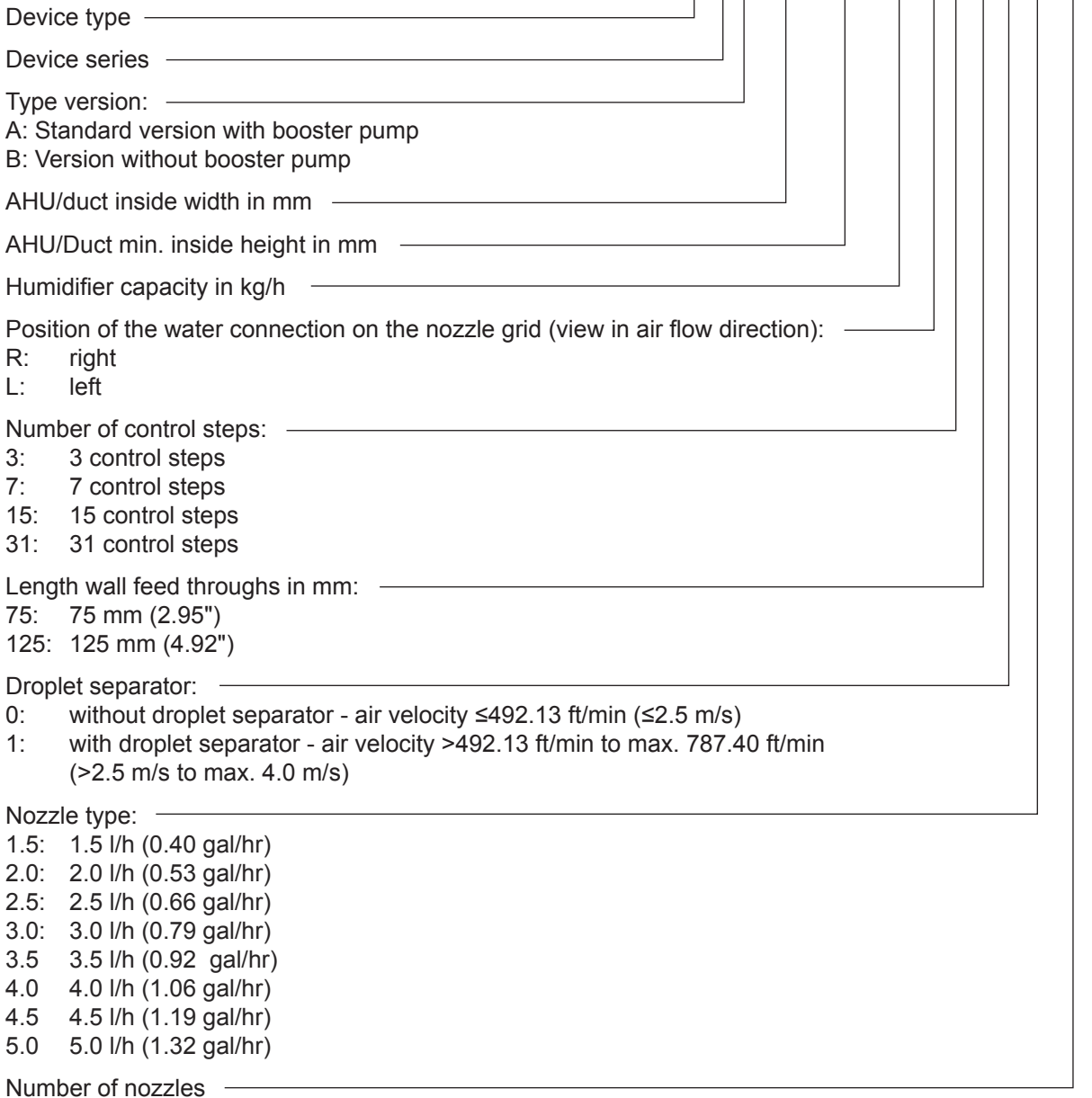

4 Mounting and installation work

4.1 Safety notes on mounting and installation work

Qualification of personnel

All mounting and installation work must be carried out only by **well qualified and trained personnel authorized by the owner**. It is the owner's responsibility to verify proper qualification of the personnel.

General notes

Prior to installation work, the ventilation system (into which the Condair DL is to be incorporated) must be taken out of operation and secured against unintentional start-up.

It is mandatory to observe and comply with the **instructions regarding the location and installation of particular components** of the Condair DL.

Observe and comply with all local regulations dealing with water and electrical installations.

Use **only the mounting accessories included in the delivery** for installing the various system components. If for some special reasons an installation with the supplied installation accessories is not feasible, choose a type of installation that is equally stable. In cases of doubt, contact your Condair distributor.

Safety

Some installation work requires removal of the unit covers of the control unit and the central unit. Please note the following:



DANGER!

Danger of electric shock!

The control unit of the Condair DL and the pump motor inside the central unit (if applicable) are mains powered. Live parts may be exposed when the control unit and/or the central unit is/are open. Touching live parts may cause severe injury or danger to life.

Prevention: The control unit of the Condair DL must be connected to the mains only after all mounting and installation work has been completed, all installations have been checked for correct workmanship and all unit covers are relocated properly locked.

Important! The frequency converter in the control unit of systems with booster pump contains capacitors. These can remain charged with a potentially deadly voltage for a certain period of time after the control unit has been disconnected from the power supply. Therefore, wait at least 10 minutes after disconnecting the power supply. Then make sure the appropriate contacts on the frequency converter and the terminals on the pump motor are free of voltage before starting any work on these components!



CAUTION!

The electronic components inside the control unit of the Condair DL are very sensitive to electrostatic discharge.

Prevention: To protect these components against damage caused by electrostatic discharge (ESD protection) appropriate measures must be taken when the control unit is open for installation work.

4.2 Installation overview

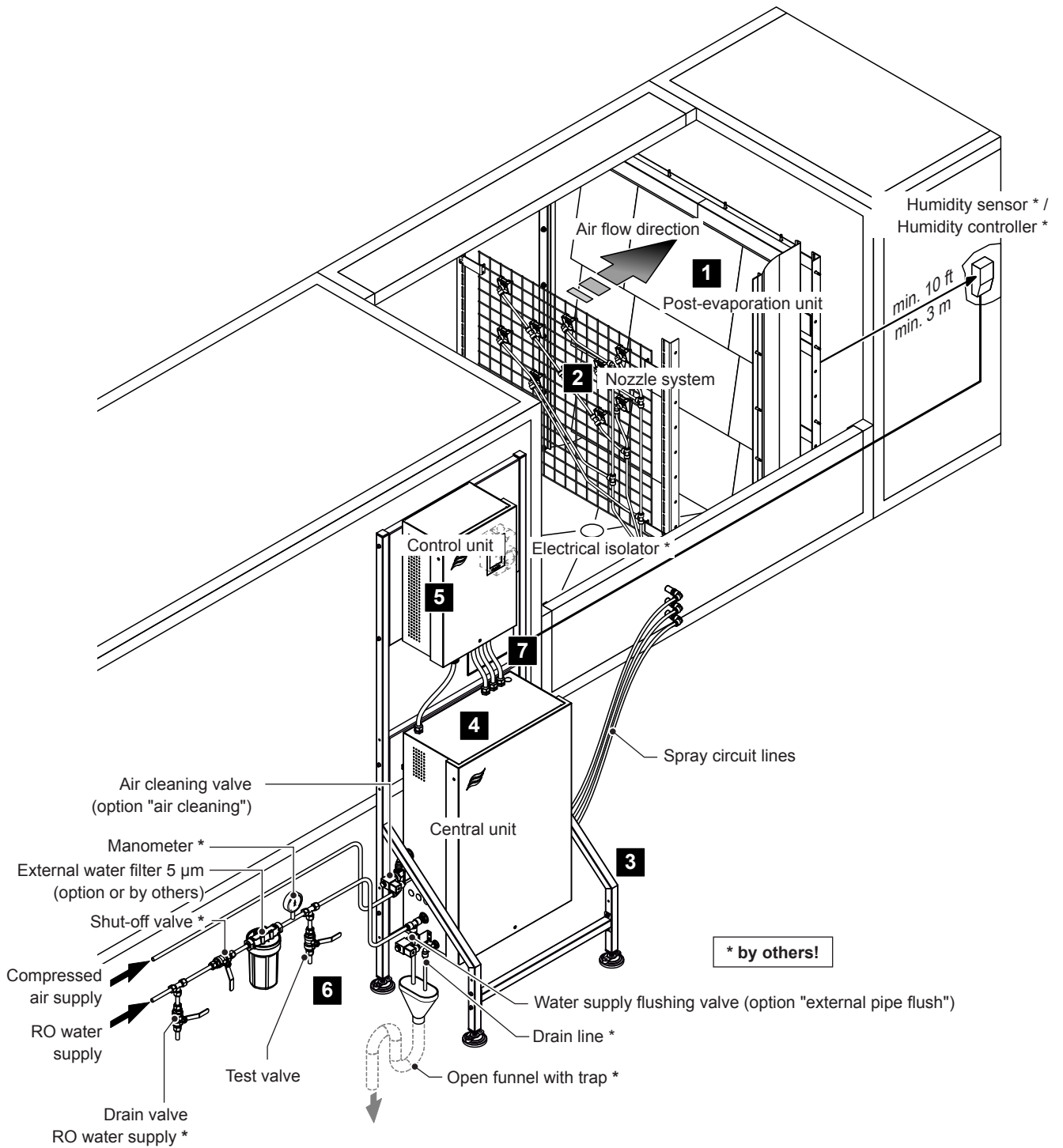

- 1 - Mounting the post evaporation unit --> see [Section 4.3](#)
- 2 - Mounting the nozzle system --> see [Section 4.3](#)
- 3 - Mounting the mounting rack --> see [Section 4.4](#)
- 4 - Mounting the central unit --> see [Section 4.6](#)
- 5 - Mounting the control unit --> see [Section 4.7](#)
- 6 - Water installation --> see [Section 4.8](#)
- 7 - Electrical installation --> see [Section 4.9](#)

Fig. 1: Installation overview Condair DL

4.3 Installation of the humidification unit

4.3.1 Positioning of the humidification unit

Usually, the design and dimensioning of the ventilation duct/AHU as well as the location of the humidification system Condair DL inside the duct are determined, recorded and set compulsory when planning the entire system. Prior to installation, however, make sure the following criteria have been taken into consideration:

- **For safety reasons the Condair DL must be installed only in rooms provided with a floor drain. If for some reason the Condair DL must be installed in a location without floor drain, it is mandatory to provide a water tub with drain below the central unit and the duct wall feed throughs and/or water sensors in the room/water tub to safely interrupt water supply in case of a leak.**
- In the area of the humidification unit the ventilation duct/AHU must be waterproof.
- **Caution, fully demineralized water is aggressive!** For this reason, all components located close to the humidification unit (duct/AHU, fastening material, drain pipe, etc.) must be made of **corrosion-proof steel** (minimum requirements according to DIN 1.4301 / AISI 304) or **plastic**.
- Make sure the duct/AHU section where the humidification unit is installed has a **sufficient load-bearing capacity**. The wet weight of the post-evaporation unit is **approx. 11.26 lbs/ft² (55 kg/m²) humidifier area**.
Important: on systems with a width >110.24" (>2800 mm) some or all vertical supports of the post-evaporation unit are supported to the duct/AHU ceiling and to the duct/AHU floor with special leg supports (see [Fig. 4](#)). On systems with a width >177.2" (>4500 mm) additionally the vertical support of the nozzle unit is supported to the duct/AHU floor with a special leg support (see [Fig. 24](#)). Make sure the mounting surface on the duct/AHU floor (or tub) and on the ceiling of the duct/AHU where the legs supports are mounted to is equipped with a reinforcement traverse.
- For installation and maintenance of the humidification unit a **inspection window** and a sufficiently large **maintenance door** must be available in the duct/AHU.
Important: inspection windows must be constructed in such a manner that they can be covered, so that no light can fall into the duct section where the humidification unit is installed (reduction of the growth of microorganisms)
- **Important! An air filter must be installed at the air inlet of the humidification unit. The filter must meet the quality standards MERV 13-14 or better.**
- In case of low ambient temperature the duct must be insulated to prevent the moist air from condensing inside the duct.
- A minimum distance of 0.5 m to upstream components (e.g. heater, air cooler, etc.) must be observed.
- In order to avoid drops seeping over the ceramic elements, an **even air flow over the full cross section** of the post-evaporation unit must be guaranteed. Air conditioning equipment mounted upstream or downstream of the Condair DL humidification unit (e.g. silencers, air cooler with a lamella droplet separator, heating coils, air filters, cross arms, changes of the direction of the airstream due to branches or curves, etc.) or cross-sectional variations may cause air turbulences or air backflow which prevent proper functioning of the Condair DL. If necessary, rectifiers or perforated plates must be installed on the building side before the humidifier.
If the air velocity in the duct before the post-evaporation unit exceeds 492.13 ft/min (2.5 m/s), a droplet separator must be installed.
Important: For systems without droplet separator the air speed between nozzle grid and post-evaporation unit must nowhere exceed 492.13 ft/min (2.5 m/s) for systems without droplet separator or 787.40 ft/min (4.0 m/s) for systems with droplet separator. Please note that not the average air speed, but the maximum air speed must be below 492.13 ft/min (2.5 m/s) or 787.40 ft/min (4.0 m/s), respectively.

- Inspection doors: for installation as well as for control and maintenance purposes, either a inspection door directly before the nozzle grid or a inspection door between the nozzle grid and the post-evaporation unit must be provided in the duct/AHU. For easier installation and maintenance purposes, we recommend an additional inspection door in the duct/AHU after the post-evaporation unit.
- **The humidification unit must be installed in a stainless steel lined section, equipped with a sloping drain pan. Drains before and after the post-evaporation unit are required (single drain pan), or a drain before the separation as well as drains before and after the post-evaporation unit (separated drain pans). Each drain must be individually piped to the waste water system via a siphon. For hygienic reasons connect the drain pipes with an open outlet to the waste water system of the building.**

Note: The effective height of the siphon drain depends on the duct pressure. Correct dimensioning of the siphon drain is the customer's responsibility.

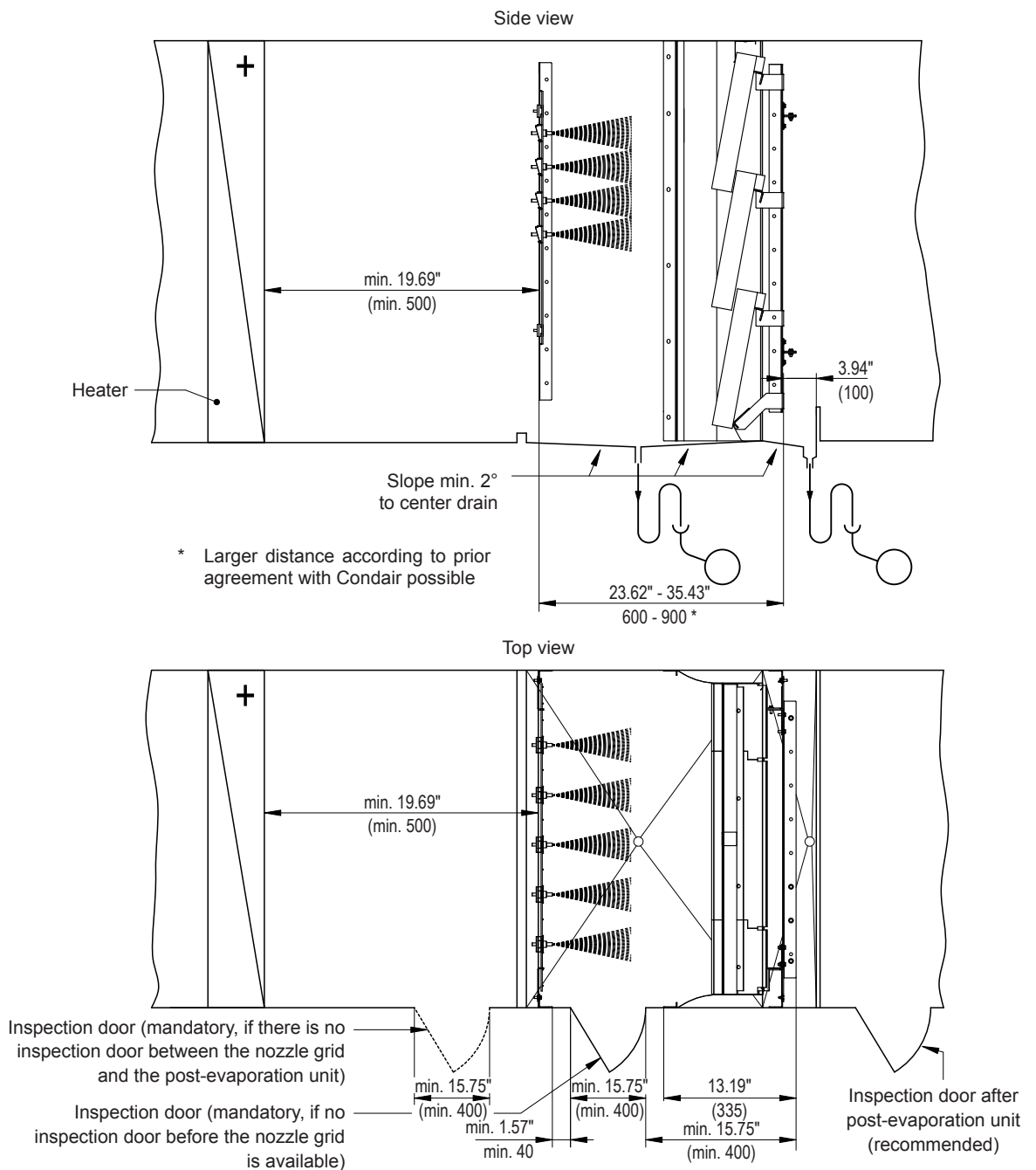

Fig. 2: Positioning of the humidification unit with inspection door between as well as before and after the humidification unit - dimensions in inches (mm)

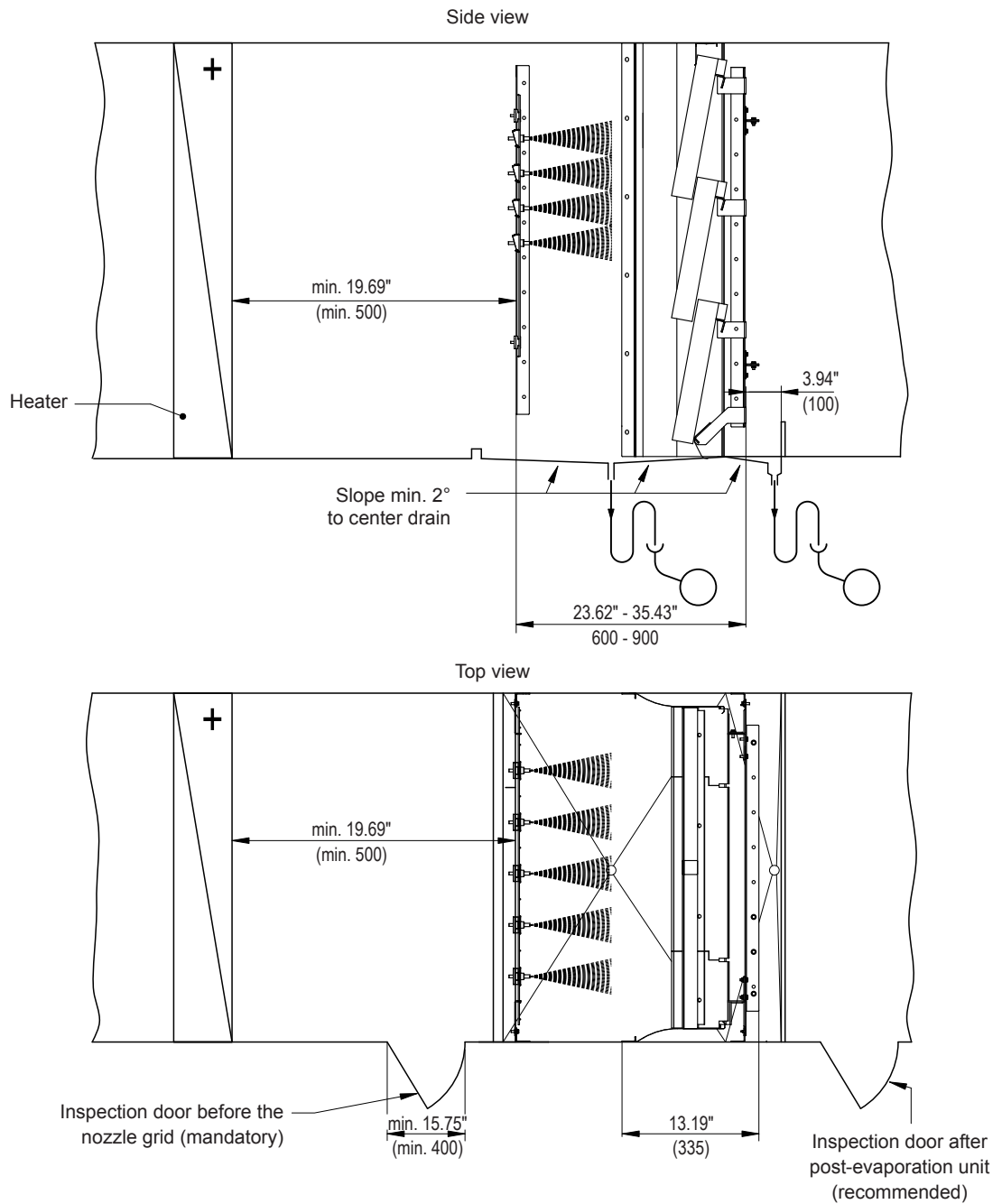

Fig. 3: Positioning of the humidification unit with inspection door before and after the humidification unit - dimensions in inches (mm)

4.3.2 Mounting the post-evaporation unit

4.3.2.1 Overview frame constructions post-evaporation unit

The following figure shows an overview of the frame constructions of the post-evaporation unit depending on the air duct/AHU size.

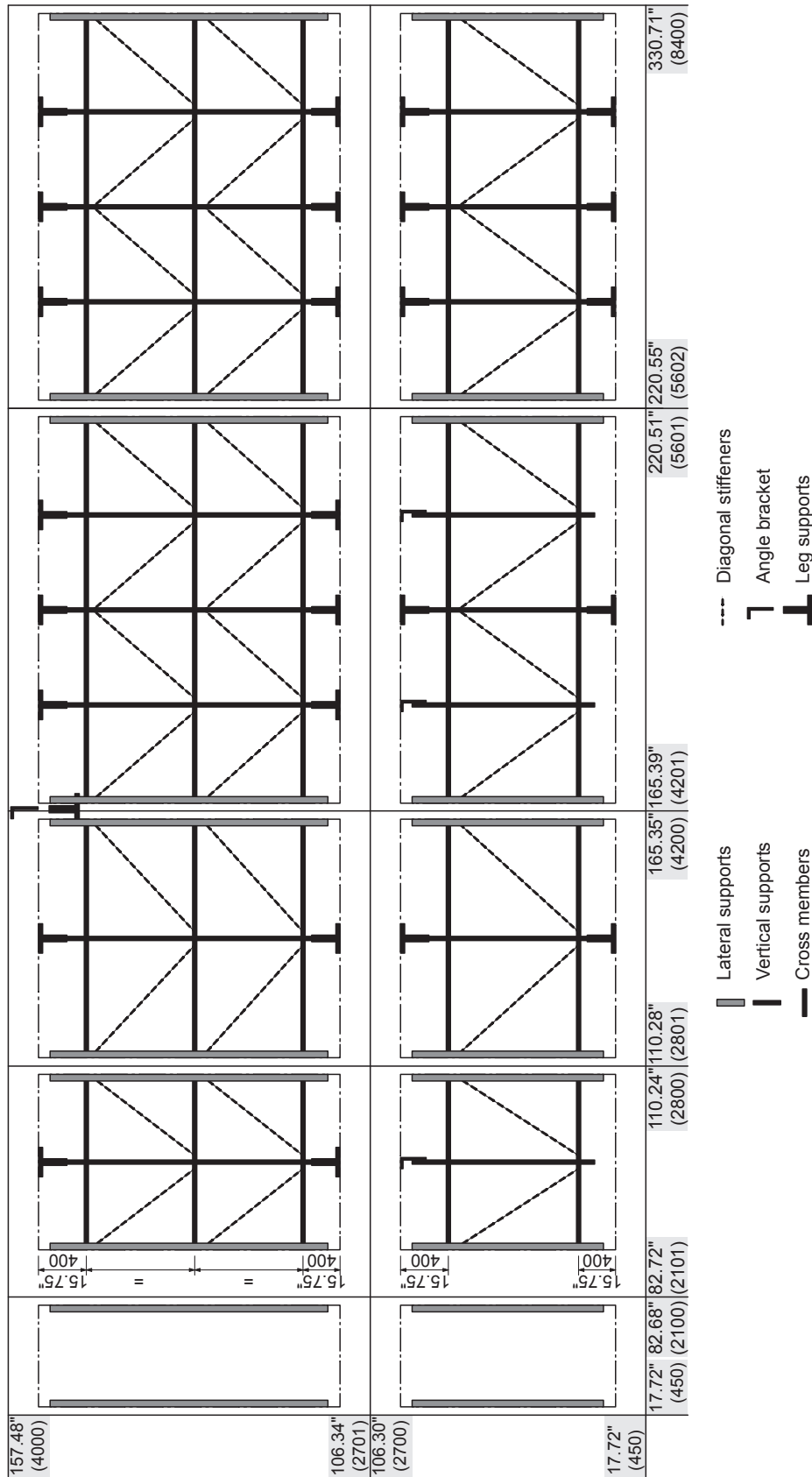

Fig. 4: Overview frame constructions post-evaporation unit - duct inner dimensions in Inch (mm)

4.3.2.2 Mounting procedure post-evaporation unit

1. Marking the positions of the fastening elements inside the duct/AHU:

- Mark the position of the topmost fastening holes (or welding studs) for the fastening of the lateral supports of the post-evaporation unit "A", the nozzle system "C" and the fastening profiles for the lateral sealing plates "B" on both duct walls using the drilling template supplied.
- Mark the position of the outmost fastening holes (or welding studs) for the fastening of the left-most and right-most fastening profiles for the upper sealing plates "D" on duct ceiling using the drilling template supplied.

Note: For marking the fastening holes (or welding studs) "D" the drilling template must be bent 90° on the indicated position.

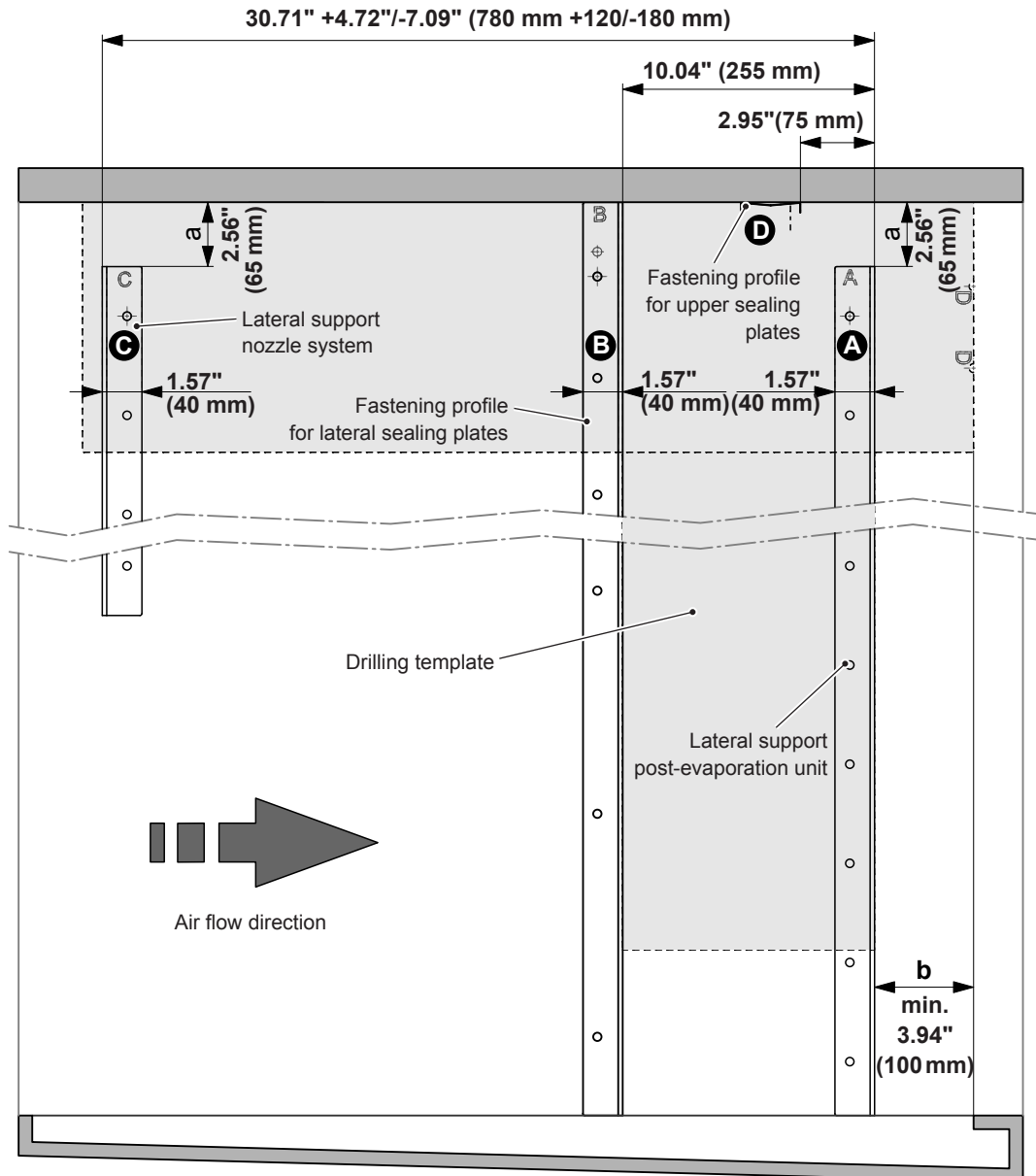

Fig. 5: Positioning of the fastening elements (side view)

2. Mount the base plate:

Note: this step must be carried out only on systems equipped with a droplet separator.

- Attach the base plate to the tub ledge behind the post evaporation unit using the self-tapping screws 6.3 x 25 mm.

Note: Make sure the base plate is flush with the duct walls on each side. If necessary cut ends of base plates to fit in place.

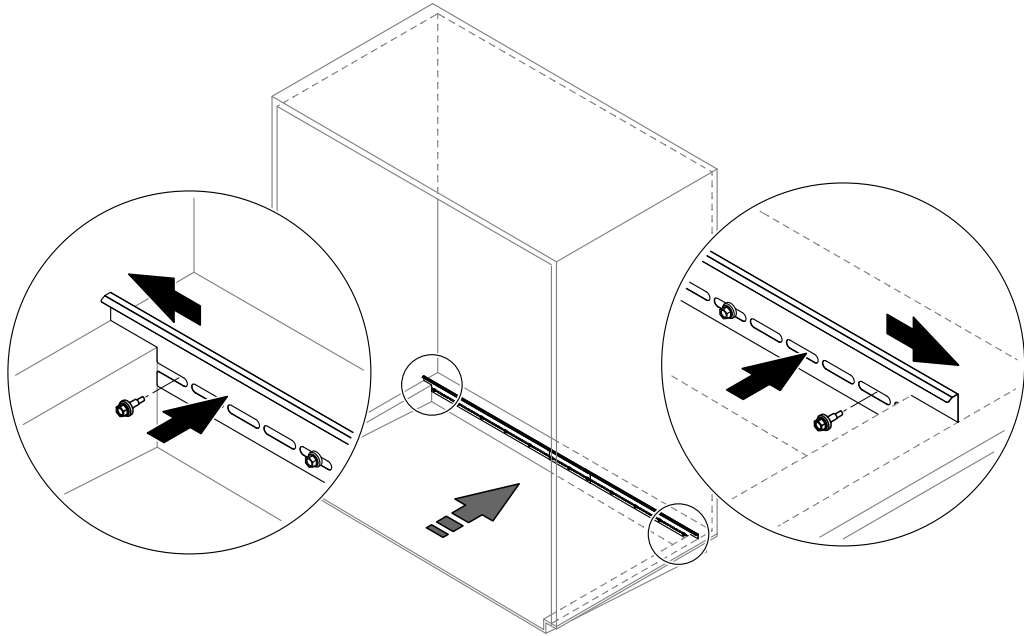

Fig. 6: Mounting the base plate

3. Mount the lateral supports of the post-evaporation unit to the duct walls:

- Align the lateral supports with the "TOP" labeled mounting bracket on top with an identical distance to the duct ceiling (**target measure "a": 2.56" (65 mm), admissible range: 0...3.54" (0...90 mm)**) and with a distance "b" of 3.94" (100 mm) to the intersection of the AHU, then fix them via the topmost fastening hole to the duct wall using an appropriate self-tapping screw (do not tighten the screw yet).

Important: to be able to mount the optional droplet separator the distance of 100 mm to the intersection of the AHU must be maintained.

- Align both supports at right angles to the duct ceiling and check the distance to the duct ceiling once more (the distance must be identical for both supports). Then, fix both supports approx. every 11.81" (300 mm) with appropriate self-tapping screws to the duct walls.

Note: evenly allocate the self-tapping screws over the entire length of the supports.

- This step must be carried out only on ducts with a height >82.68" (>2100 mm) where the supports consist of several profiles: fix the additional supports flush and in line with the upper support approx. every 11.81" (300 mm) with appropriate self-tapping screws to the duct walls.

Note: evenly allocate the self-tapping screws over the entire length of the supports.

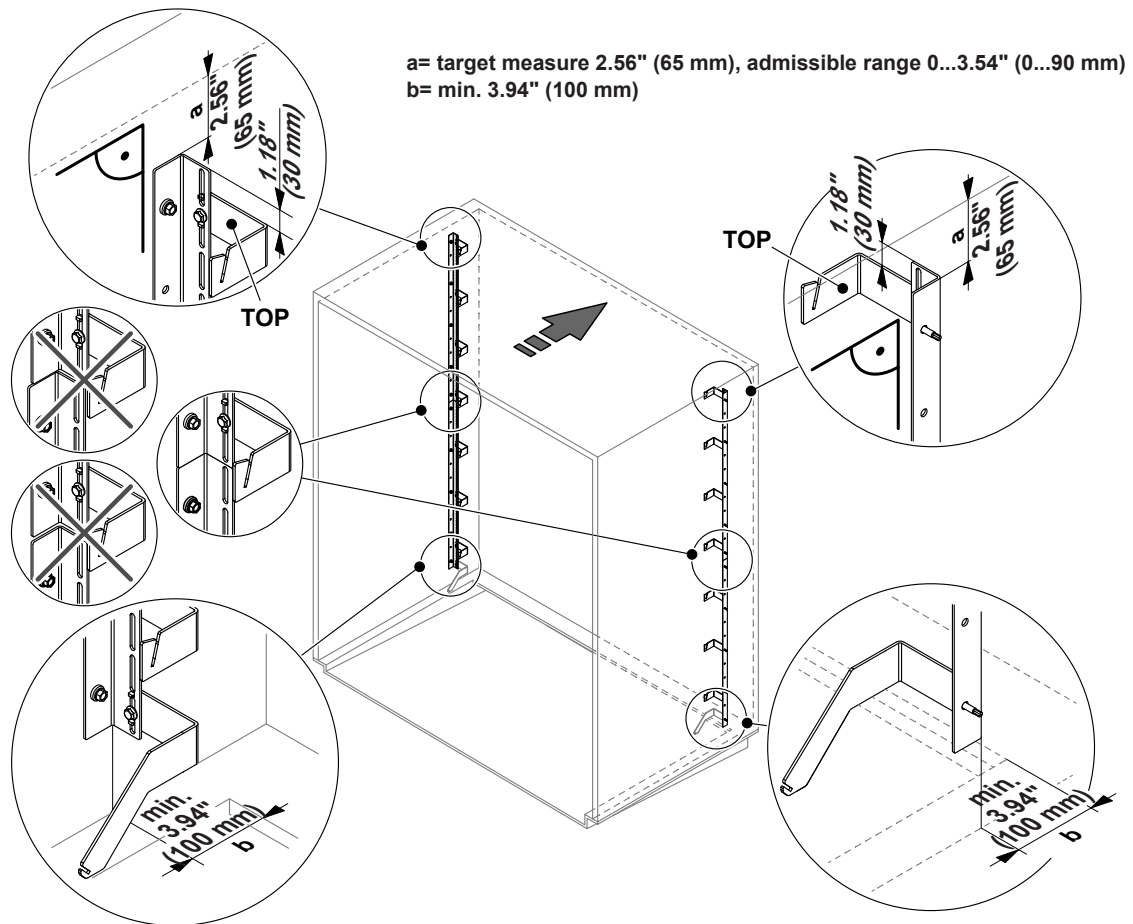

Fig. 7: Mounting the lateral supports

4. Mounting the fastening profiles for the upper sealing plates:

Important: if only one fastening profile is used in the duct width, the fastening profile must be centrally aligned to the duct width in a distance of 2.95" (75 mm) to the lateral supports, then fixed to the duct ceiling using appropriate self-tapping screws.

If several fastening profiles are used in the duct width, proceed as follows:

- If not done already in step 1, mark the position of the outmost fastening holes for the fastening of the leftmost and rightmost fastening profiles for the upper sealing plates "D" on the duct ceiling using the bent drilling template.
- Fix both fastening profiles to the duct ceiling via the marked hole using appropriate self-tapping screws. Then, align both fastening profiles to each other using a cord. When aligned, fix the two fastening profiles to the duct ceiling using appropriate self-tapping screws.
- Fix the remaining fastening profiles evenly allocated over the duct with and flush to the first mounted fastening profiles to the duct ceiling using appropriate self-tapping screws.

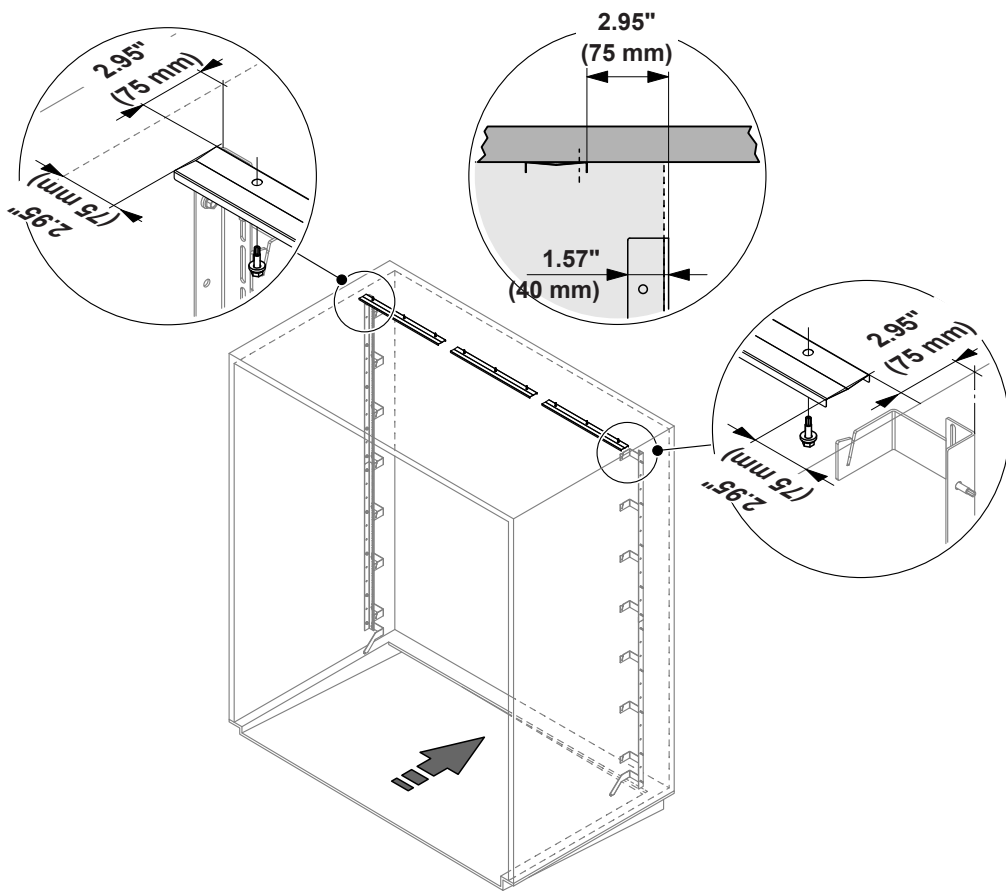

Fig. 8: Mounting the fastening profiles for the upper sealing plates

5. Mounting the fastening profiles for the lateral sealing plates:

- If not done already with the drilling template in step 1, mark the position of the lateral fastening profiles for the lateral sealing plates on both sides of the duct. Distance between fastening profiles and post-evaporation supports 10.04" (255 mm).
- Fix fastening profiles with a distance of 10.04" (255 mm) to the post-evaporation supports and right-angled to the duct ceiling to the duct wall using appropriate self-tapping screws. Do not tighten the screws yet.

Note: Make sure the lateral fastening profiles are evenly allocated over the duct height and in line one below the other and that the lowest profiles are flush with the bottom of the duct and the topmost profiles are flush with the duct ceiling.

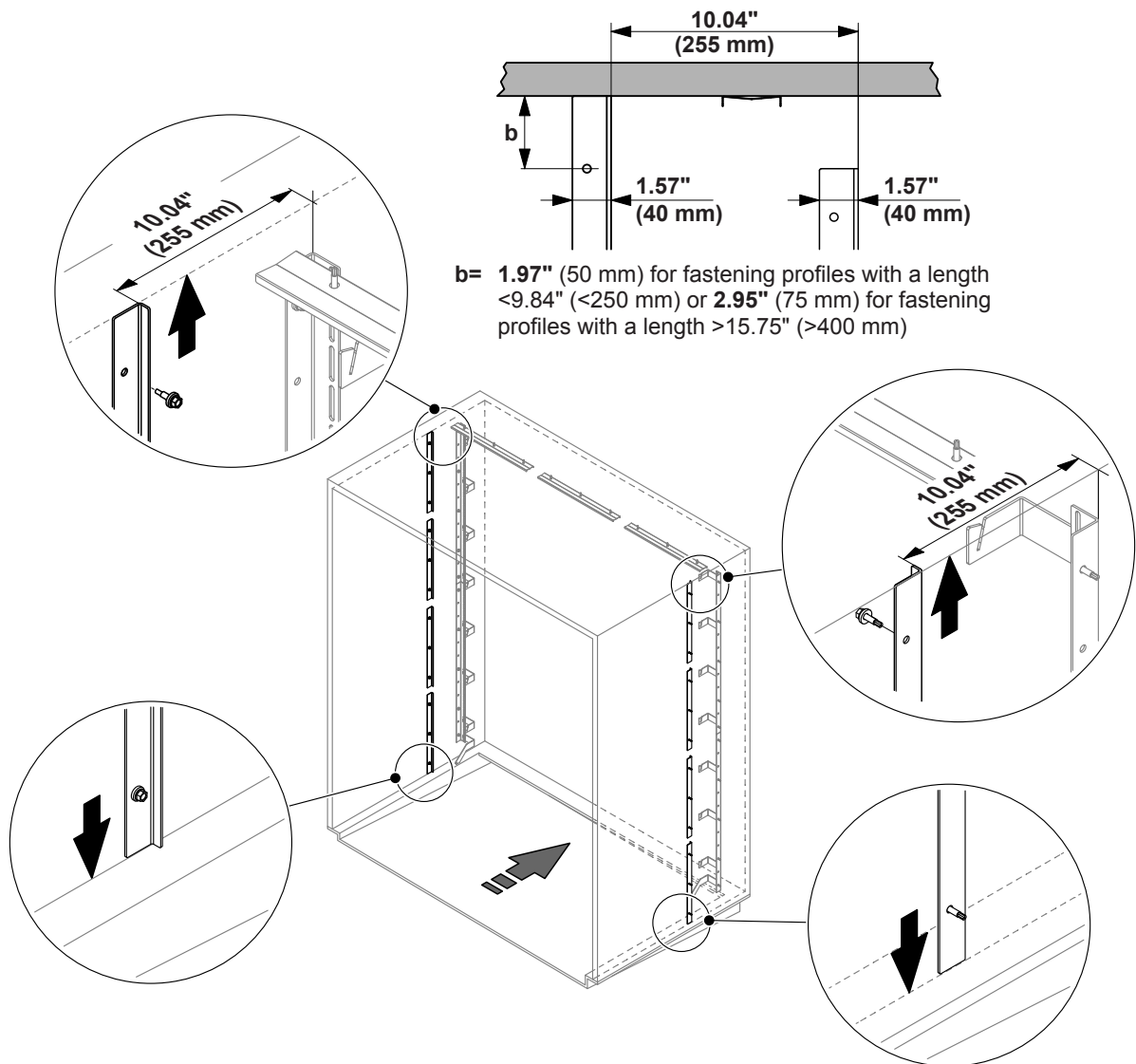

Fig. 9: Mounting the fastening profiles for the lateral sealing plates

6. Mount the cross members:

Note: This step must be carried out only on air ducts /AHU's with a width >82.68" (>2100 mm).

- For air ducts/AHU's with a width >82.68" (>2100 mm) the cross members are supplied in sections and must be bolted together on site. Proceed as follows: arrange cross member sections as shown below and fix them together using the screws M6 x 16 mm and nuts supplied. Exactly align cross member sections and fasten the screw connections.
- Slightly loosen the four screw connections, with which the mounting plates are attached on both sides to the cross members, so the mounting plates can be moved.
- From behind (view in air flow direction) hang up the cross members at the appropriate vertical position to the lateral supports of the post-evaporation unit, then push the cross members downwards until they come to a stop. Now, fasten all screw connections of the cross members.

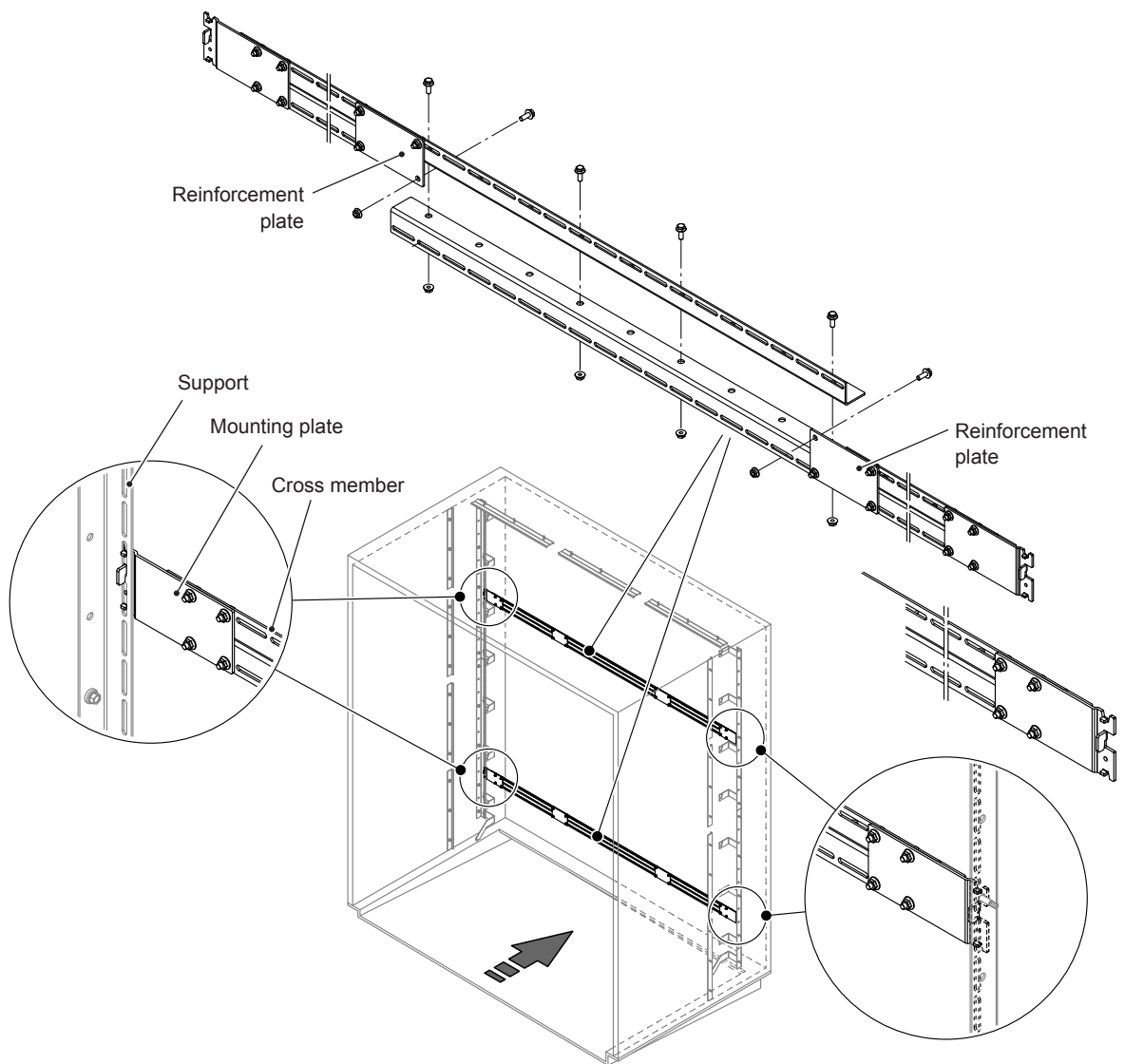

Fig. 10: Mounting the cross members

7. Mount the vertical support(s):

Note: This step must be carried out only on air ducts /AHU's with a width 82.68" (>2100 mm).

7a. Assembling the vertical support(s):

Note: This step must be carried out only on air ducts /AHU's with a height 78.74" (>2000 mm).

For air ducts/AHU's with a height 78.74" (>2000 mm) the vertical supports are supplied in sections and must be bolted together on site. Proceed as follows: Arrange the vertical support sections (with the "TOP" labeled mounting bracket on top) and fix them together using the screws M6 x 16 mm and nuts supplied. Exactly align vertical support sections and fasten the screw connections.

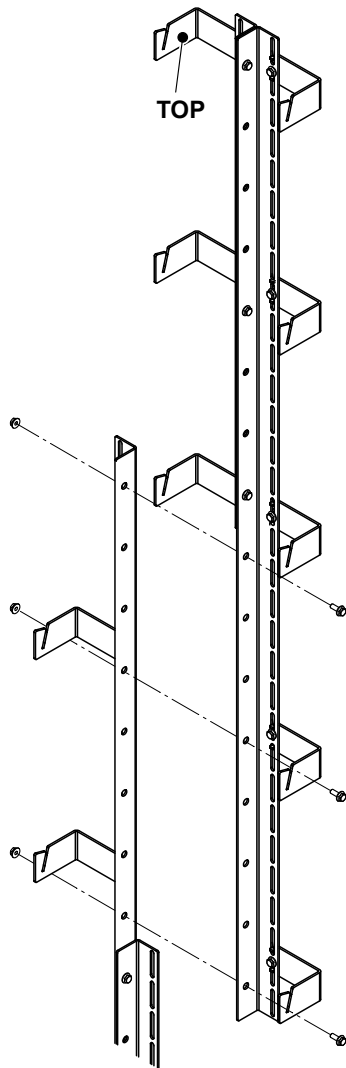

Fig. 11: Assembling the vertical support(s)

Note: for stability reasons some or all vertical supports (depending on the height and the width of the AHU/air duct) are fixed with special leg supports to the duct floor and duct ceiling (see overview frame constructions of the post-evaporation unit in [Section 4.3.2.1](#)). Please refer to steps [7b](#) and [7c](#) for mounting the vertical supports with angle brackets or leg supports.

7b. Mount the vertical support(s) with angle brackets

- If necessary, loosen the two screw connections fixing the angle bracket(s) to the vertical support(s) and position the angle bracket(s) in such a manner that the distance between the leg of the angle bracket and the upper edge of the vertical support has the same distance as the upper edge of the two lateral supports have to the duct ceiling (see [Fig. 5](#) and detail A in [Fig. 12](#)). Fasten the two screw connections again.

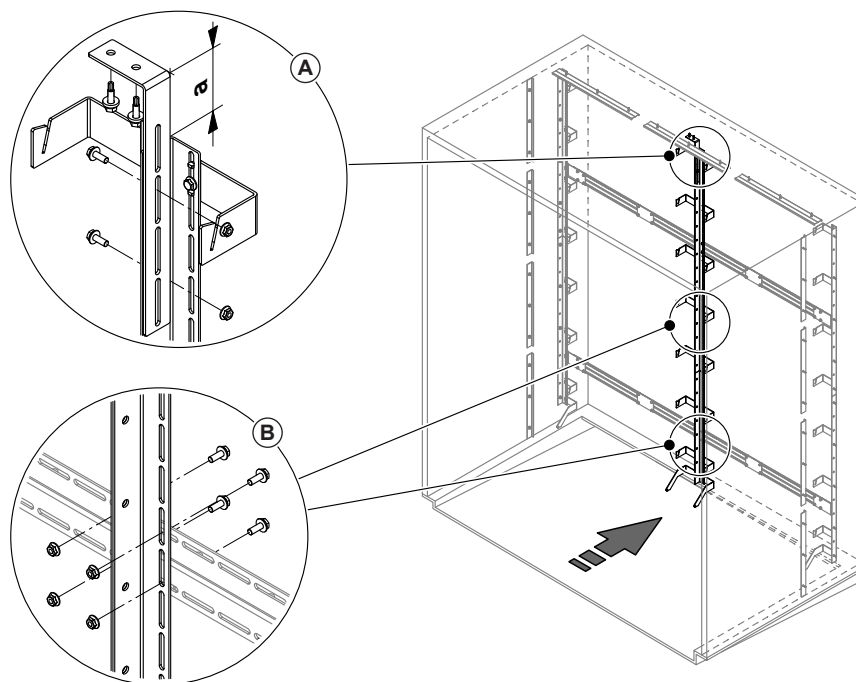

Fig. 12: Mounting the vertical support(s)

- Mark horizontal position(s) of the vertical support(s) on the cross members (one vertical support is always in the middle of the duct, several vertical supports must be evenly allocated over the duct width). From the front (view in air flow direction) attach the vertical support(s) with the angle bracket on top to the cross members, then shift upwards until it comes to a stop and fix the vertical support(s) four screws M6 x 16 mm and nuts to the cross members (see detail B in [Fig. 12](#)). Slightly fasten the screw connections only.
- Check distance between upper edge of the vertical support(s) and the duct ceiling as well as the vertical alignment of the vertical support(s) by measuring the distance between the vertical support(s) and the duct walls on top and on the bottom.
Important! The distance between the upper edge of the vertical support(s) to the duct ceiling must be identical to the distance between the upper edge of the two lateral supports of the post-evaporation unit to the duct ceiling. If necessary, align vertical support(s) horizontally and vertically.
- Fix angle bracket of the vertical support(s) with two appropriate self-tapping screws to the duct ceiling (see detail A in [Fig. 12](#)).
- Check dimensions again and realign if necessary. Then, tighten all screw connections.

7c. Mount the vertical support(s) and the top and bottom leg supports:

Note: this step must be carried out only on air ducts /AHU's with a width >177.17" (>4500 mm).

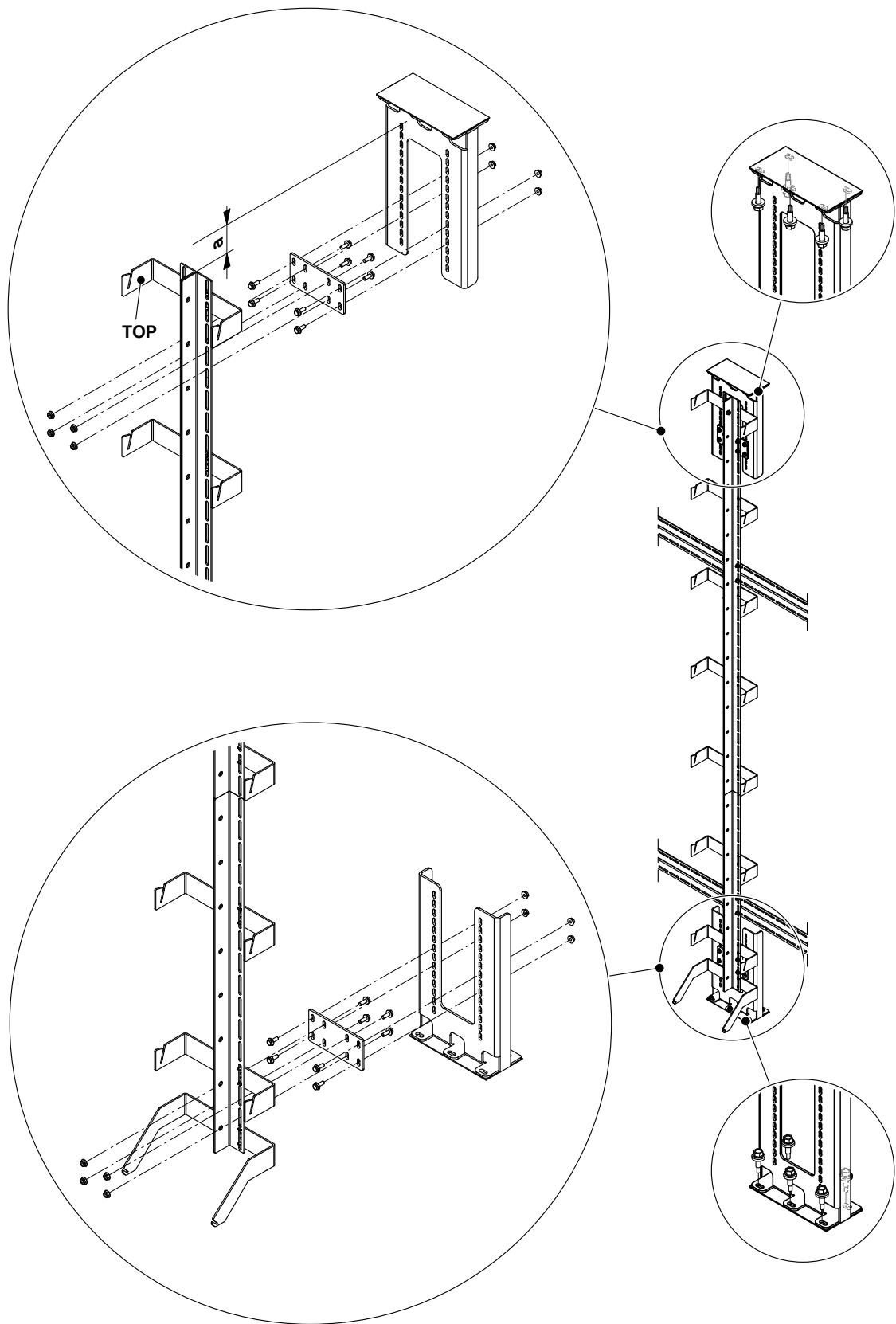

Fig. 13: Mounting the middle vertical support and the top and bottom leg supports

Note: in the duct section where the leg supports are fixed to the duct/AHU floor (or tub) and the duct ceiling a reinforcement traverse may be installed where required. However, make sure the lower leg support does not stand in the water during operation. On ducts/AHU's with a tub divided in longitudinal direction the leg supports may also be fixed to the tub partitionment if a sufficient load bearing capacity is assured.

- From the front (view in air flow direction) attach the middle vertical support to the topmost cross member with four screws M6 x 16 mm and nuts supplied. Make sure the vertical support is exactly in the middle of the air duct/AHU and that the distance between the upper edge of the vertical support has the same distance to the air duct/AHU ceiling as the other vertical supports have (see step "7b").
- Align vertical support exactly vertical, then fix it to the other cross member(s) with four screws M6 x 16 mm and nuts supplied. Then, fasten all screw connections on the cross members.
- Fix fastening plates of the leg supports at the appropriate position on the upper and lower end to the vertical support with four screws M6 x 16 mm and nuts supplied. Slightly fasten the screw connections only.
- Fix leg supports to the fastening plates with four screws M6 x 16 mm and nuts supplied. Slightly fasten the screw connections only.
- Shift the upper leg support to the air duct/AHU ceiling, then fix the leg support to the traverse/ tub partitionment using five appropriate self-tapping screws.
Important: Before fastening the upper leg support to the air duct/AHU ceiling make sure the topmost cross member is flush over the entire duct width.
- Shift the lower leg support down to the air duct/AHU floor, then fix the leg support to the traverse/ tub partitionment using five appropriate self-tapping screws.
Important: Before fastening the lower leg support to the duct/AHU floor make sure the lowermost cross member is flush over the entire duct width.
- Check dimensions again and realign if necessary. Then, tighten the screw connections on both leg supports.

Important! If your system has no service door behind the post-evaporation unit, now place the droplet separator elements in the duct, just behind the frame construction.

8. Mounting the diagonal stiffeners (see also frame construction overviews in [Fig. 5](#)):

Note: this step must be carried out only on air ducts /AHU's with a width 82.68" (>2100 mm).

- First fix the lower stiffener sections from the front (view in air flow direction) with a screw M6 x 16 mm and nut supplied with a distance of approx. 100 mm to the middle of the vertical support(s) to the cross member(s) - use appropriate oblong hole in the lower row of the cross member(s) (see detail A in [Fig. 14](#)). Then, push the stiffener sections in the oblong hole of the cross member against the duct walls until it comes to a stop and slightly fasten the screw connections.
- Fix the upper stiffener sections from the back (view in air flow direction) with a screw M6 x 16 mm and a nut supplied in such a way to the lateral support or the middle vertical support (only applicable for air ducts/AHU's with a width 177.17" (>4500 mm)) that the overlap of the upper and lower stiffener sections is at least 3.94" (100 mm) (see detail B and C in [Fig. 14](#)). Then, push the stiffener sections in the oblong holes downwards until it comes to a stop and slightly fasten the screw connections.
- Overlap the upper and lower stiffener sections and fix overlap with three screws M6 x 16 mm and nuts supplied (see detail C in [Fig. 14](#)).
- Finally, fix the lower stiffener sections with a second screw M6 x 16 mm and nut supplied in the upper row of oblong holes to the cross member(s) (see detail A in [Fig. 14](#)). Then, fasten all screw connections on the diagonal stiffeners.

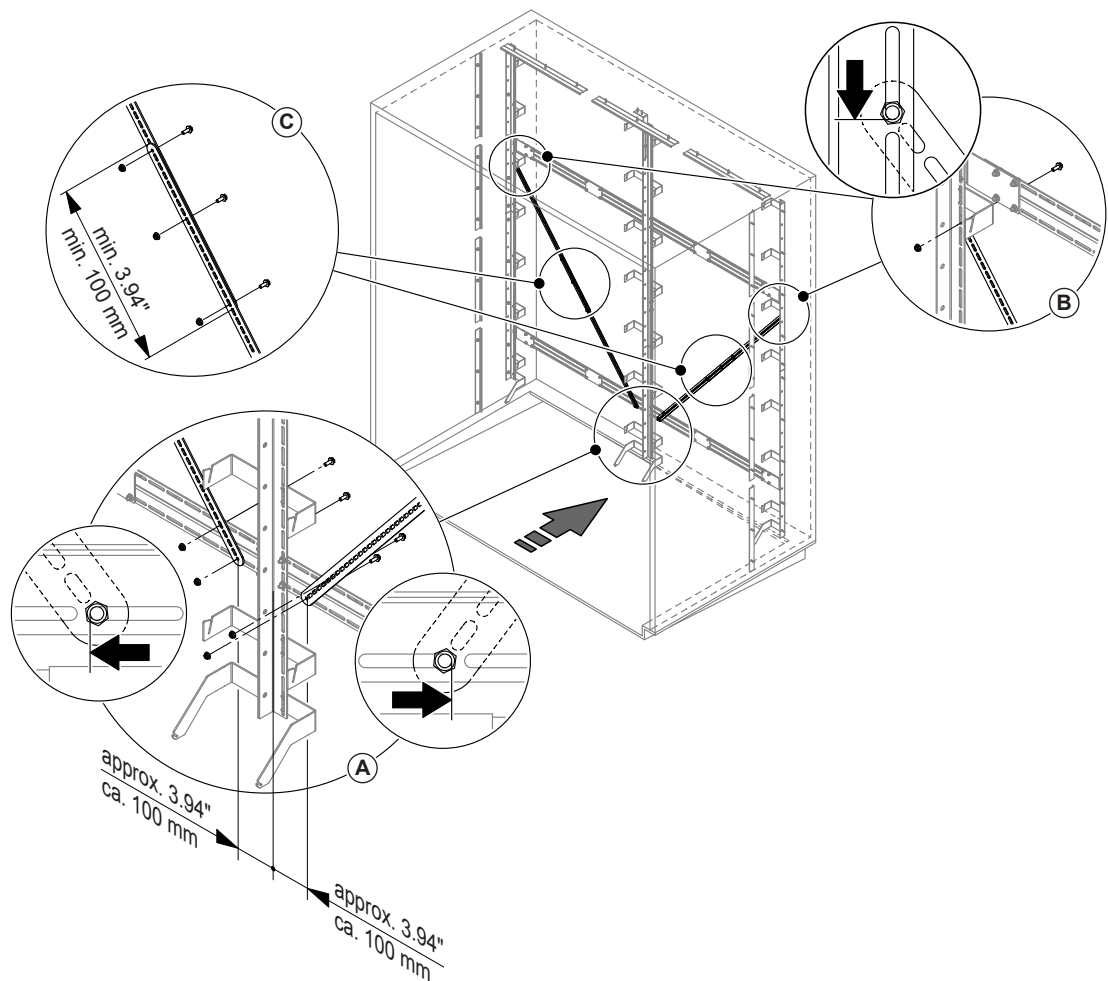

Fig. 14: Mounting the diagonal stiffeners

9. Mounting the droplet separator elements:

Note: this step must be carried out only if your system is equipped with a droplet separator.

On systems with a width up to 82.68" (2100) mm the supplied cross members must be mounted prior to the installation of the droplet separator.

- Slightly loosen the four screw connections, with which the mounting plates are attached on both sides to the cross members, so the mounting plates can be moved.
- From behind (view in air flow direction) hang up the cross members at the appropriate vertical position ((see overview frame constructions in [Section 4.3.2.1](#)) to the lateral supports of the post-evaporation unit, then push the cross members downwards until they come to a stop. Now, fasten all screw connections of the cross members.

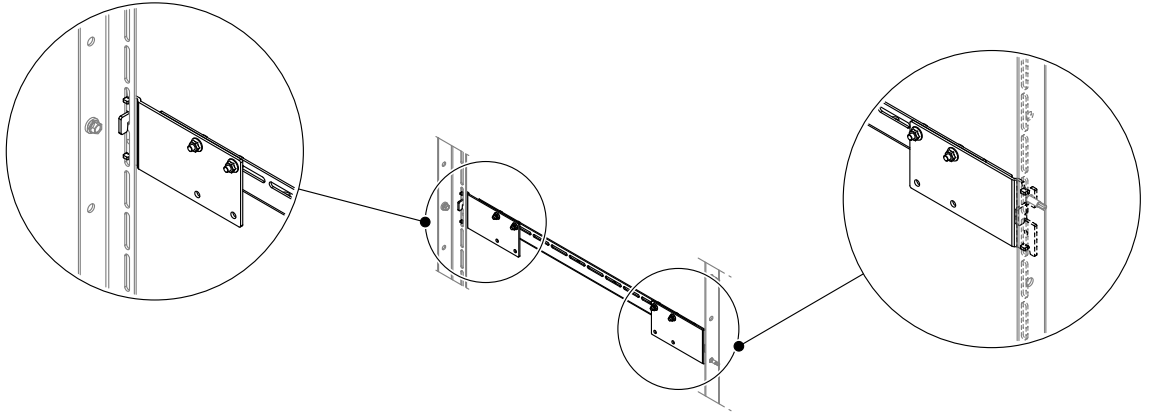

Fig. 15: Mounting the cross members for droplet separator mounting on systems with a width up to 82.68" (2100 mm)

- Fix the two upper brackets at the appropriate position to all droplet separator elements as shown below using the thread plates and the M6 x 20 mm hexagon socket screws supplied.
Important! Tighten the screws by hand only to a point at which the brackets can still be moved.

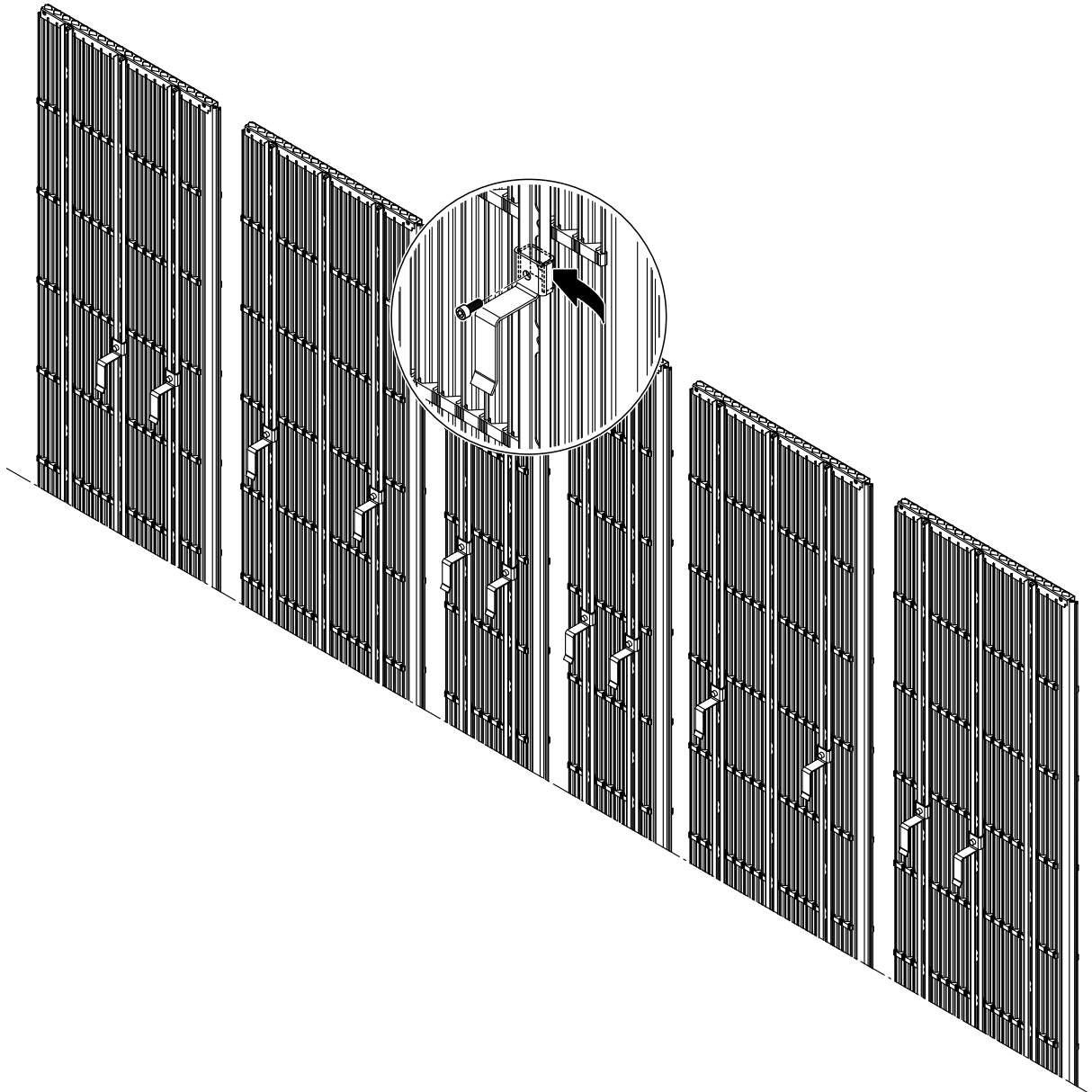

Fig. 16: Mounting the upper brackets to the droplet separator elements

- From the back, hang all droplet separator elements to the topmost cross member. Fix the lower brackets to the droplet separator elements using the thread plates and the M6 x 20 mm hexagon socket screws supplied (tighten the screws by hand only to allow later adjustment of the brackets).
- Couple all droplet separator elements at the top and bottom with a connector piece "A" and two hexagon socket screws M6 x 10 mm as well as with the short snap lashes "B" supplied (attach right below the row of the long snap lashes).
- Align the droplet separator centrally, at equal distance to the left and the right wall of the air duct/ AHU.
- Vertically align the droplet separator in such a way that the lower end of the droplet separator is below the top edge of the base plate. Then tighten the screws of the brackets.

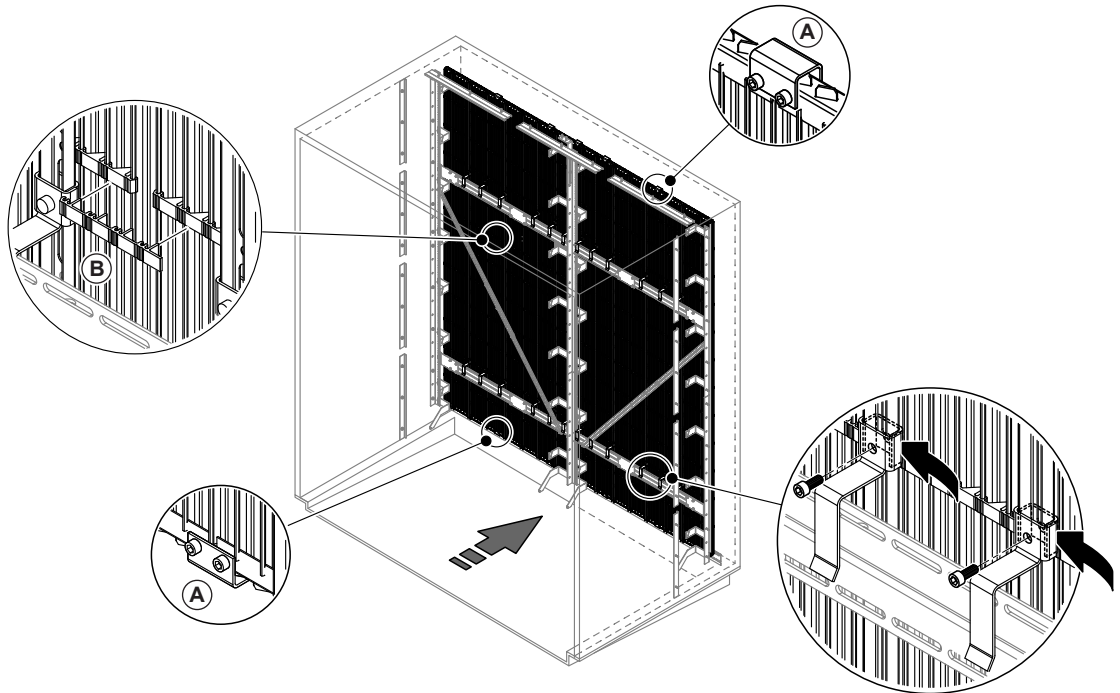

Fig. 17: Mounting the droplet separator elements

10. Mounting the lateral sealing plates:

- Start on the bottom shift the lateral sealing plates with the slightly bent surface behind the fastening profiles. **Important! Make sure the sealing plates on top of each other covers and overlaps the subjacent sealing plates in order to ensure that no water can flow behind the subjacent sealing plates.** Slightly tighten the self-tapping screws of the appropriate fastening profile after the sealing plates have been positioned to ensure that the sealing plates do not slip downwards but can still be moved.
- Shift the topmost sealing plate flush to the duct ceiling and the lowest sealing plate flush to the duct floor. Evenly allocate the overlapping of the sealing plates over the duct height, then tighten all self-tapping screws on the fastening profiles.

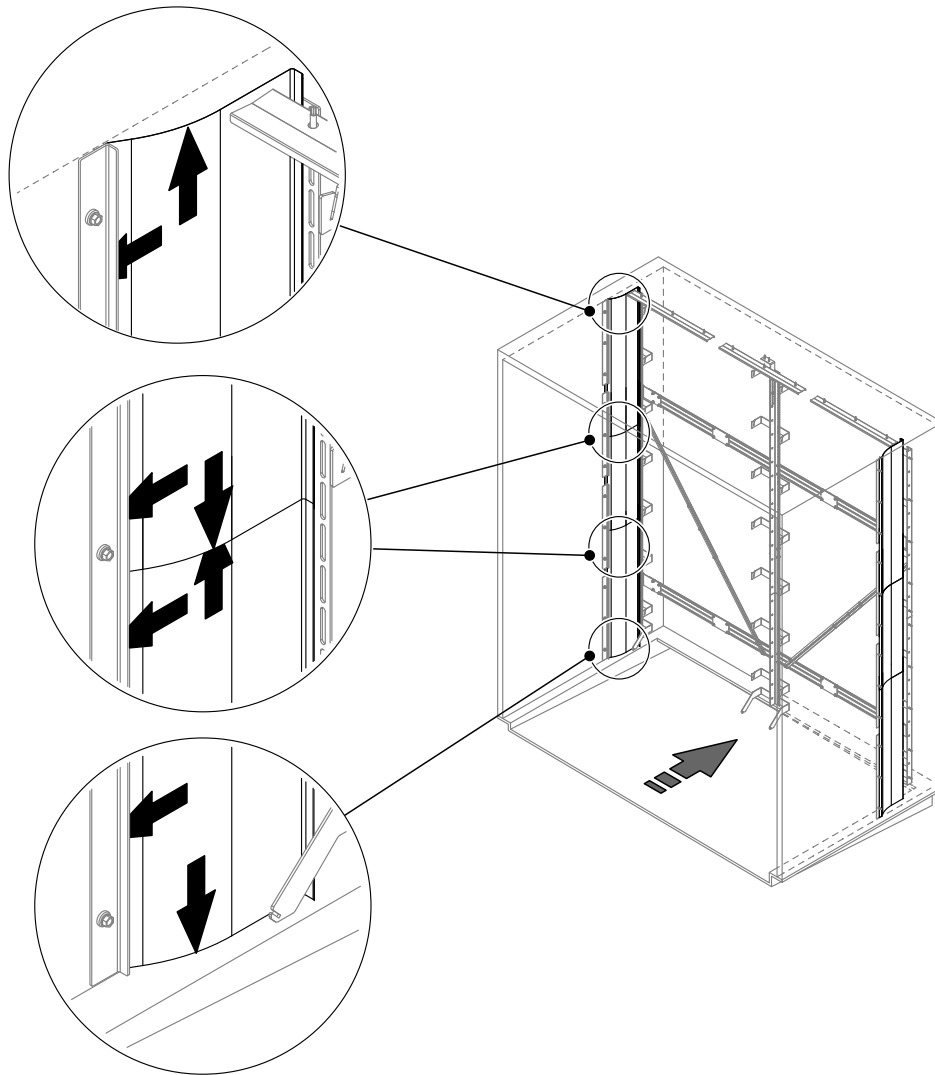

Fig. 18: Mounting the lateral sealing plates

11. Inserting ceramic support profiles:

- Insert the ceramic support profiles into the lowest row of holders. Make sure the support profiles are inserted such that the slots on each side of the support profiles rest on the holder.

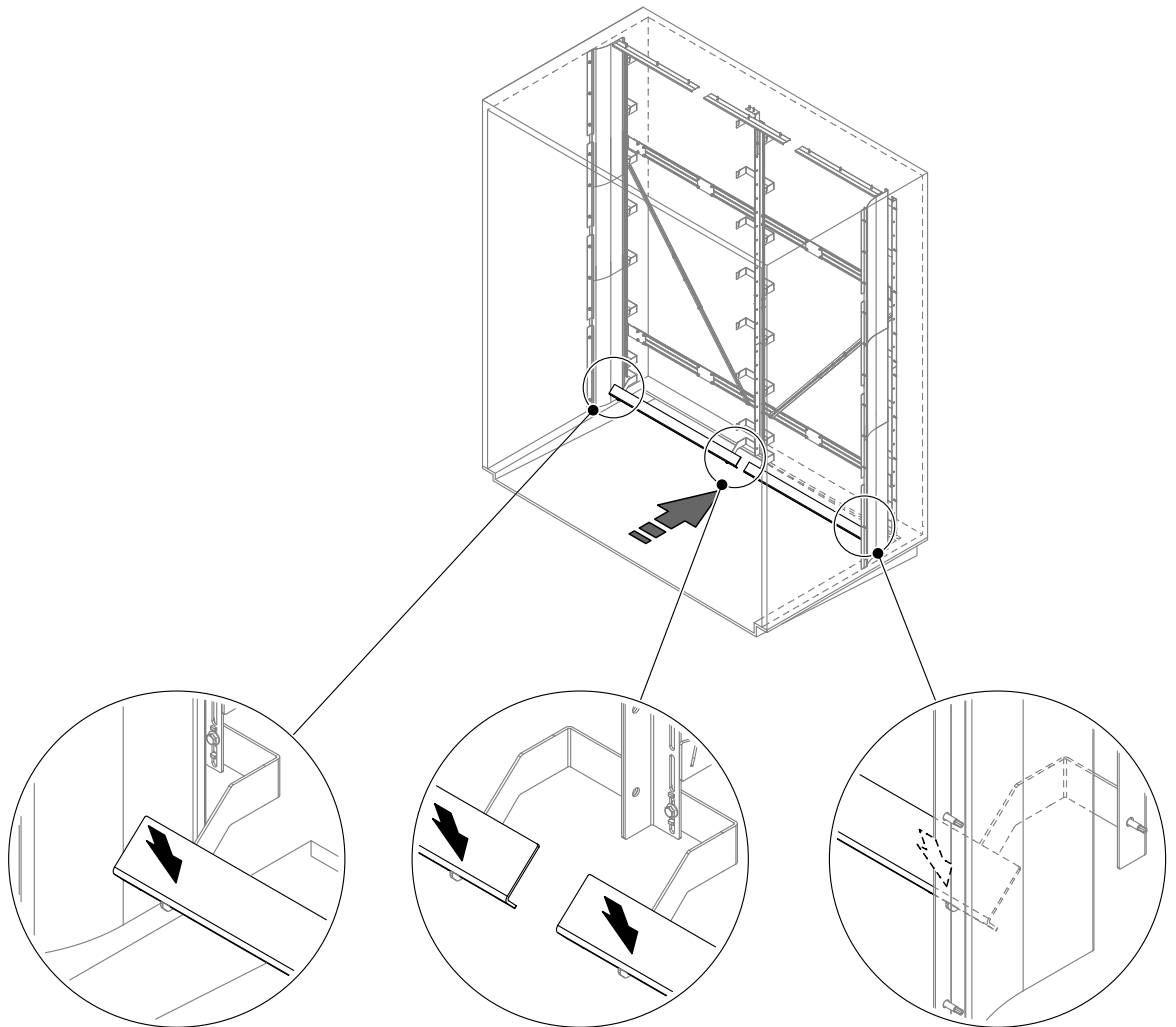

Fig. 19: Inserting ceramic support profiles

12. Mounting the tub rubber sealing:

- Fix tub rubber sealing with the clips to the ceramic support profiles as shown below (longer part of the clip is on the side of the rubber sealing). Cut rubber sealing on both sides of the duct to the appropriate length. Make sure rubber sealing is flush with the edge of the tub and the lateral sealing plates on both duct sides.

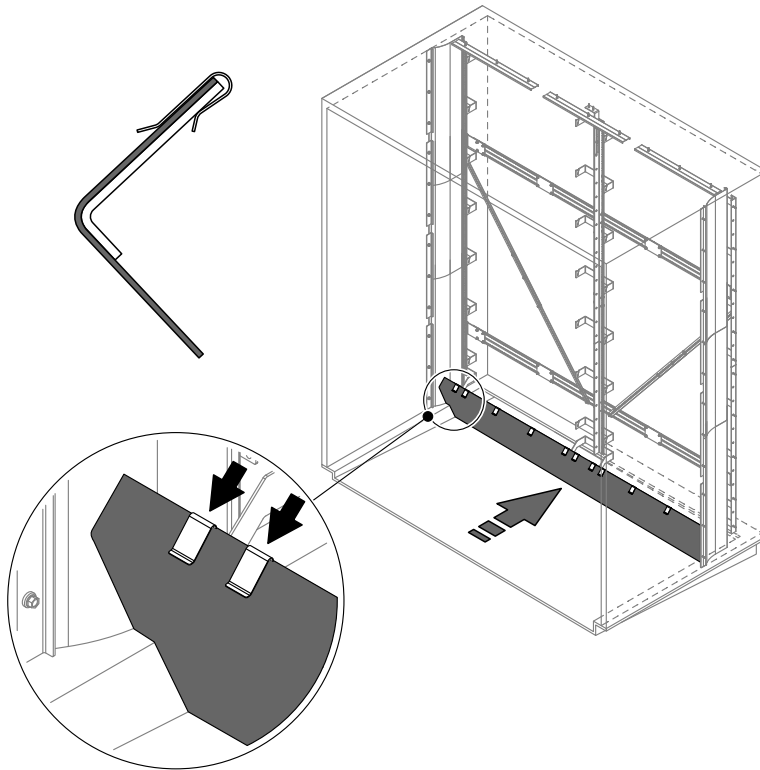

Fig. 20: Mounting the tub rubber sealing

13. Inserting ceramic carrier profiles:

- Insert the ceramic carrier profiles into holders. Make sure the carrier profiles are inserted such that the slots on each side of the carrier profile rest on the holders.

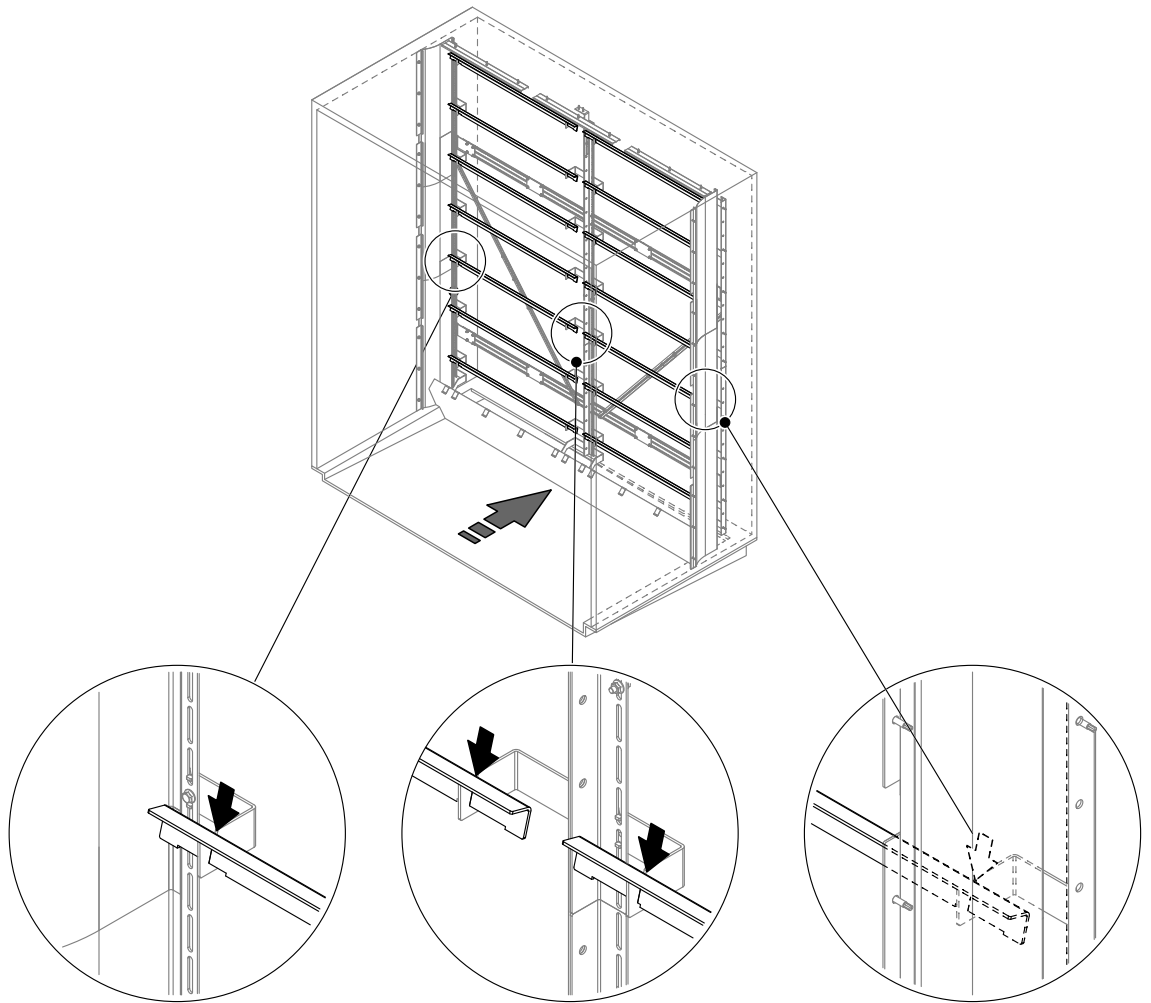

Fig. 21: Inserting ceramic carrier profiles

14. Mount the ceramic plates:



WARNING!
Risk of injury

The ceramic plates of the post-evaporation unit are porous and have partial sharp edges. You may injure your hands on this sharp edges or may injure your eyes by splintering ceramic parts when handling the ceramic plates.

Prevention: when handling the ceramic plates always wear protecting gloves and goggles.

- Start from the bottom left (view in air flow direction) carefully hang the ceramic plates of the bottom row onto the carrier profiles, then align the row to the middle of the duct.

Important: Make sure, the very right and very left ceramic plates have the same distance to the duct wall and that all plates properly rest against each other.

Important: On sites with ceramic plates with a height of 11.81" (300 mm), make sure these plates are mounted always in the bottom rows.

- Start from the left (view in air flow direction) carefully hang the ceramic plates of the remaining rows onto the carrier profiles and carefully align them to the subjacent ceramic plates row.

Important: Make sure the ceramic plates rows are aligned exactly below each other and that all plates properly rest against each other.

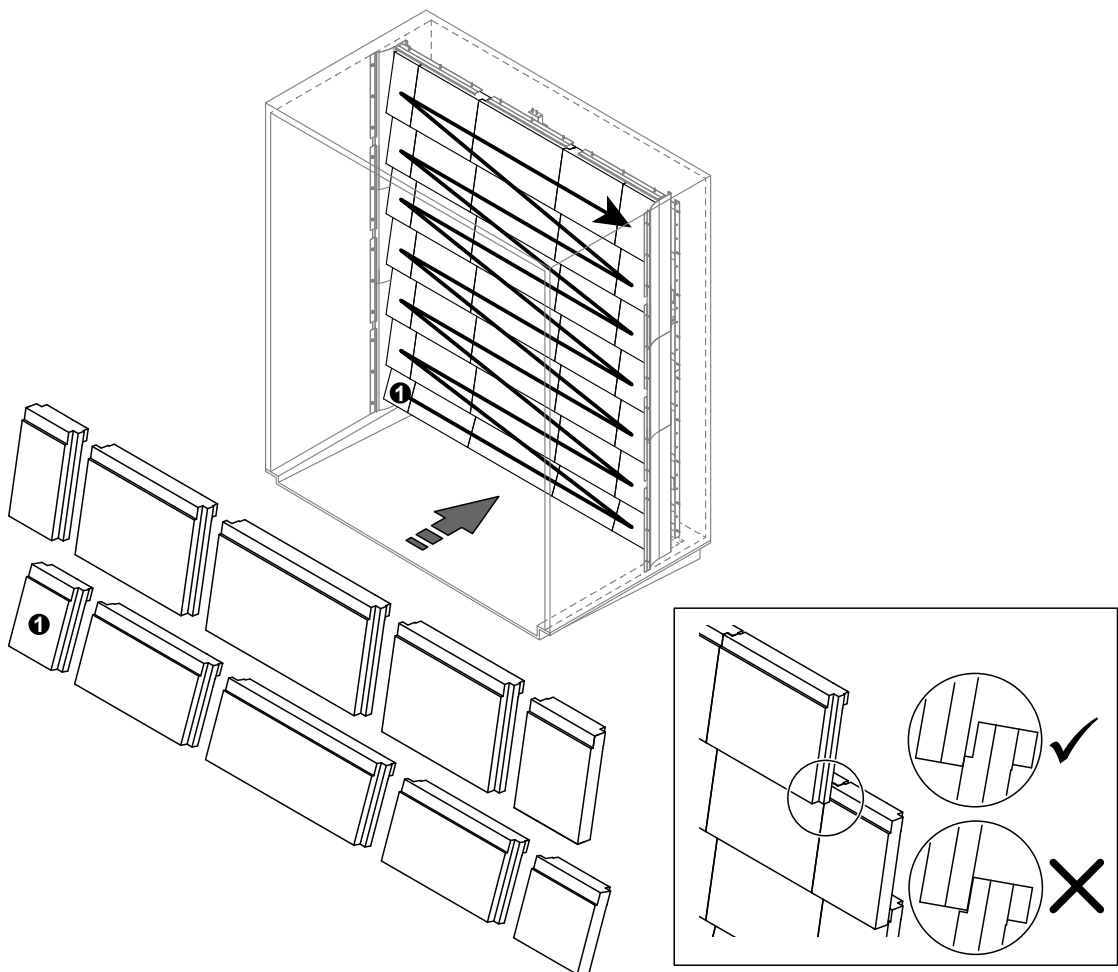

Fig. 22: Mounting the ceramic plates

15. Mount the upper sealing plates:

- Starting on one side push the upper sealing plates underneath the fastening profiles until they touch the ceramic plates of the topmost row.
- Carefully shift the very right and the very left sealing plate against the lateral sealing plates without pushing them away.

Important: Make sure the overlapping of the sealing plates are evenly allocated.

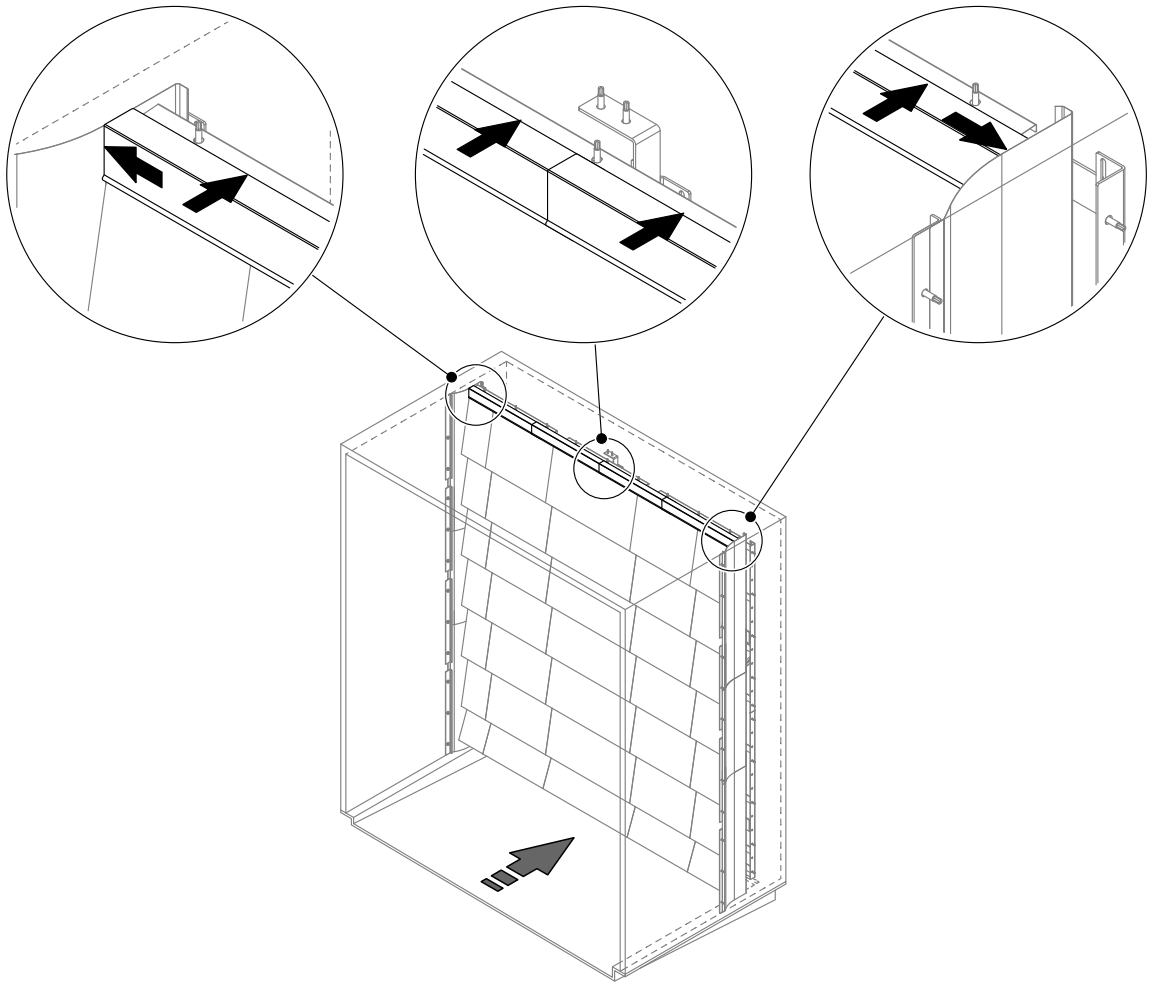

Fig. 23: Mounting the upper sealing plates

4.3.3 Mounting the nozzle system

4.3.3.1 Overview frame constructions nozzle system

The following figure shows an overview of the frame constructions of the nozzle system depending on the air duct/AHU size.

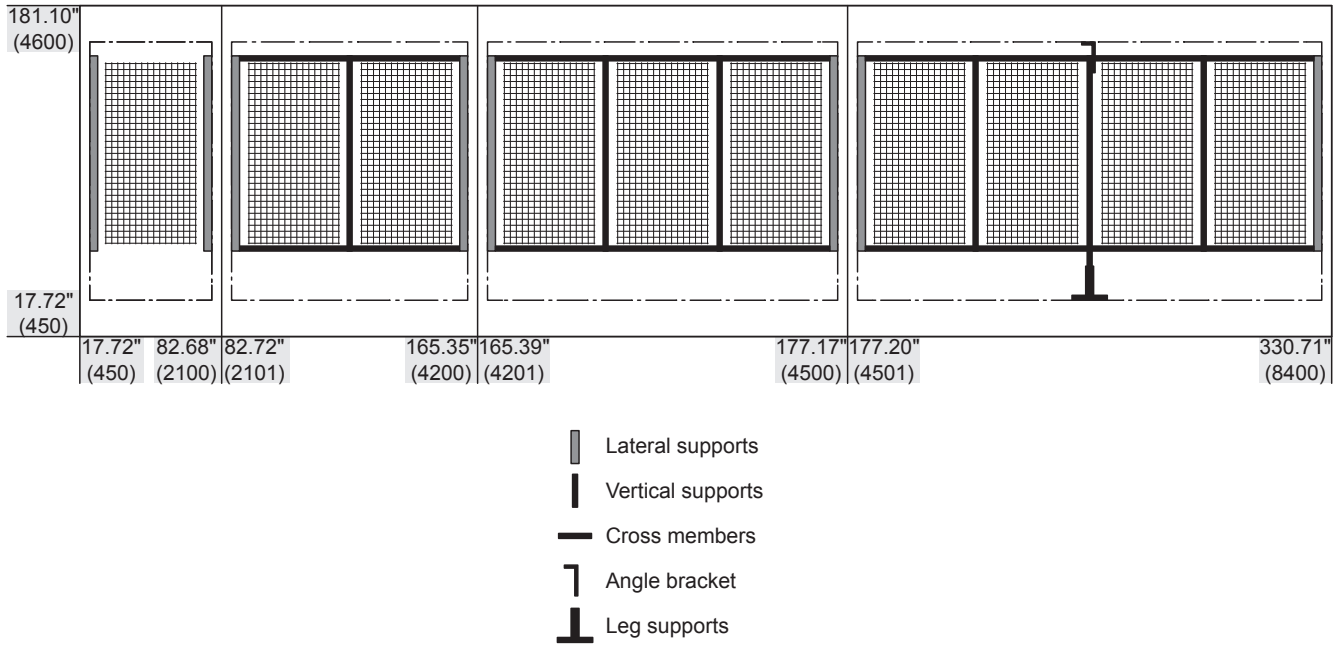

Fig. 24: Overview frame constructions nozzle system - duct inner dimensions in Inch (mm)

4.3.3.2 Mounting procedure nozzle system

1. Mount the lateral supports of the nozzle system to the duct walls:

- Align the lateral supports with the "TOP" labeled mounting bracket on top with an identical distance to the duct ceiling (**target measure "a": 2.56" (65 mm), admissible range: 0...3.54" (0...90 mm)** and with a **distance "d" of 30.71" +4.72"/-7.09" (780 mm +120/-180 mm)** to the supports of the post-evaporation unit, then fix them via the topmost fastening hole to the duct wall using appropriate self-tapping screws (do not tighten the screw yet).
- **Align both supports at right angles to the duct ceiling** and check the distance to the duct ceiling once more (the distance must be identical for both supports). Then, fix both supports approx. every 11.81" (300 mm) with appropriate self-tapping screws to the duct walls.
Note: evenly allocate the self-tapping screws over the entire length of the supports.

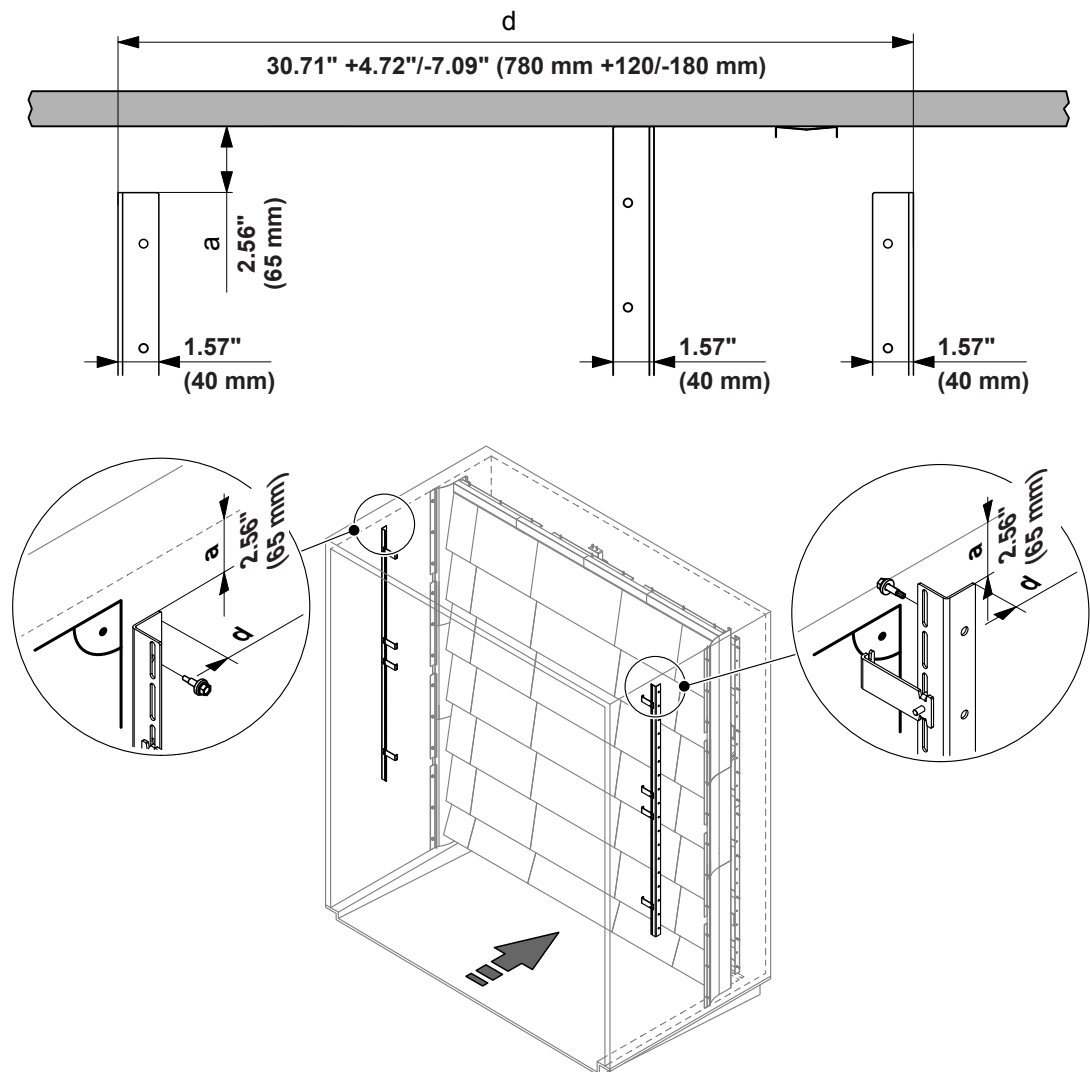

Fig. 25: Mounting the lateral supports of the nozzle system

2. Mount the cross members:

Note: this step must be carried out only on systems with more than one nozzle grid in the width.

- On systems with more than one nozzle grid in the width the cross members are supplied in sections and must be bolted together on site. Proceed as follows: arrange cross member sections as shown below and fix them together using the screws M6 x 16 mm and nuts supplied. Exactly align cross member sections and fasten the screw connections.
- Slightly loosen the four screw connections, with which the mounting plates are attached on both sides to the cross members, so the mounting plates can be moved.
- From the front (view in air flow direction) hang up the cross members at the appropriate vertical position to the lateral supports of the nozzle system, then push the cross members downwards until they come to a stop. Now, fasten all screw connections of the mounting plates.

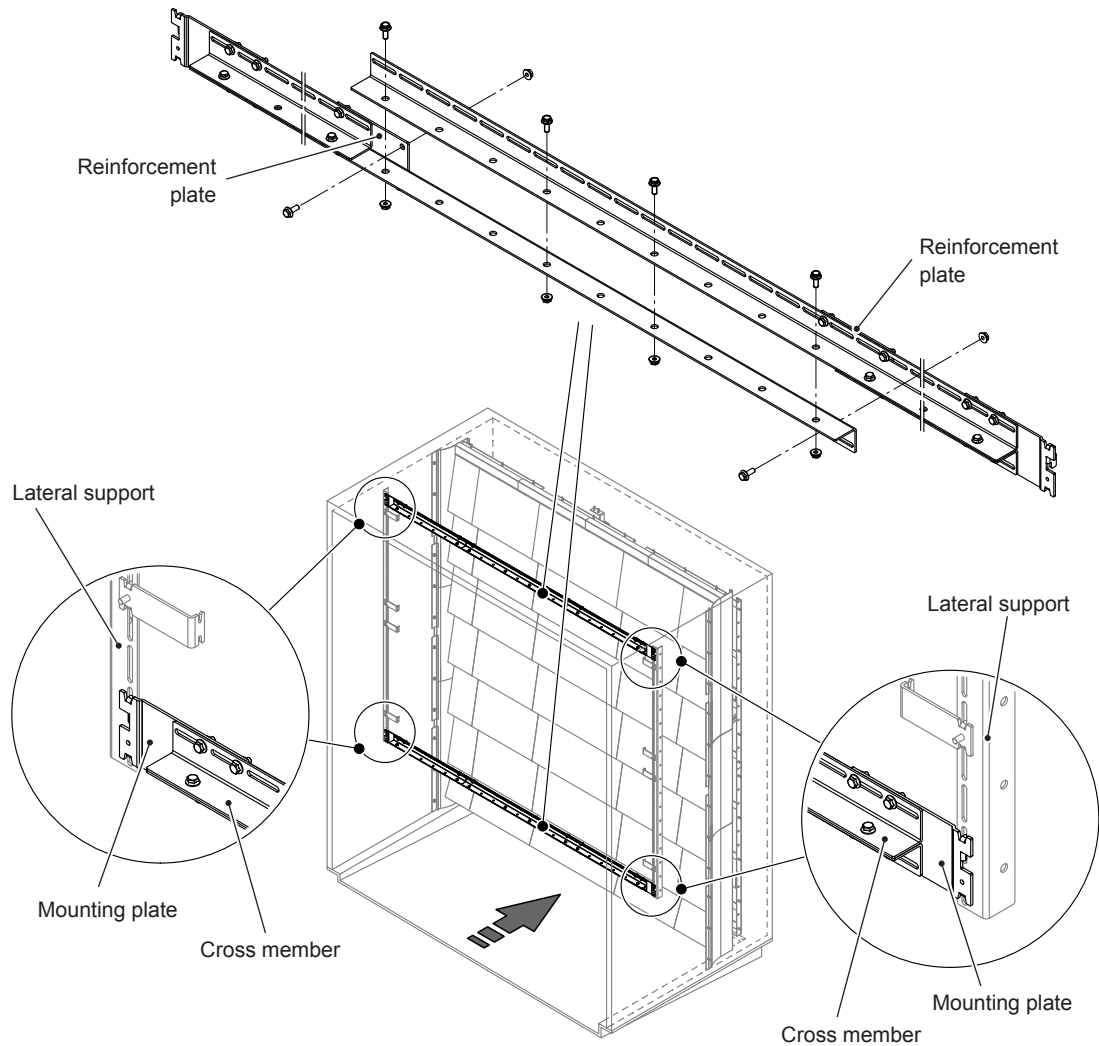

Fig. 26: Mounting the cross members

3. Mount the vertical support(s):

Note: this step must be carried out only on systems with more than one nozzle grid in the width.

3a. Assembling the vertical support(s):

Note: this step must be carried out only, if the vertical supports are supplied in sections due to plant-specific reasons.

- If the vertical supports are supplied in sections they must be bolted together on site. Proceed as follows: arrange the vertical support sections and fix them together using the screws M6 x 16 mm and nuts supplied. Exactly align vertical support sections and fasten the screw connections.

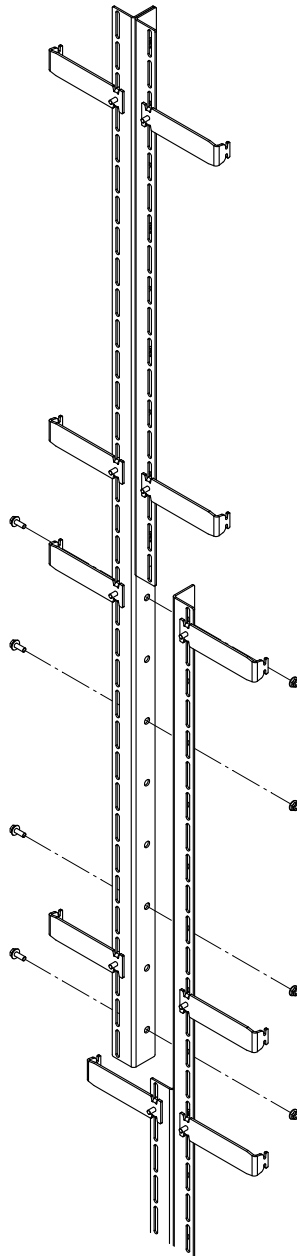

Fig. 27: Assembling the vertical support(s)

3b. Mount the vertical support(s)

Note: for stability reasons the middle vertical support for **ducts with a width >177.17" (>4500 mm)** is fixed with a special leg support to the duct floor and an angle bracket to the duct ceiling. Please refer to step "3c" for mounting the leg support and the angle bracket.

- Mark horizontal position(s) of the vertical support(s) on the cross members (one vertical support is always in the middle of the duct, several vertical supports must be evenly allocated over the duct width). From the front (view in air flow direction) attach the vertical support(s). Slightly fasten the screw connections only.
- Check distance "a" between upper edge of the vertical support(s) and the duct ceiling as well as the vertical alignment of the vertical support(s) by measuring the distance between the vertical support(s) and the duct walls on top and on the bottom.
Important! The distance "a" between the upper edge of the vertical support(s) to the duct ceiling must be identical to the distance between the upper edge of the two lateral supports of the post-evaporation unit to the duct ceiling. If necessary, align vertical support(s) horizontally and vertically.
- Tighten all screw connections.

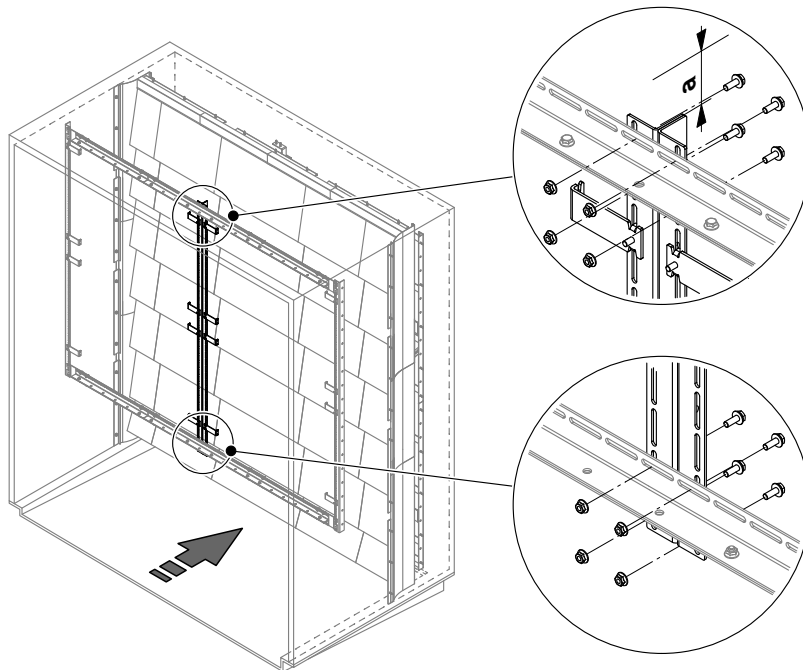

Fig. 28: Mounting the vertical support(s)

3c. Mount the middle vertical support and the top and bottom leg supports:

Note: this step must be carried out only on air ducts /AHU's with a width >177.17" (>4500 mm).

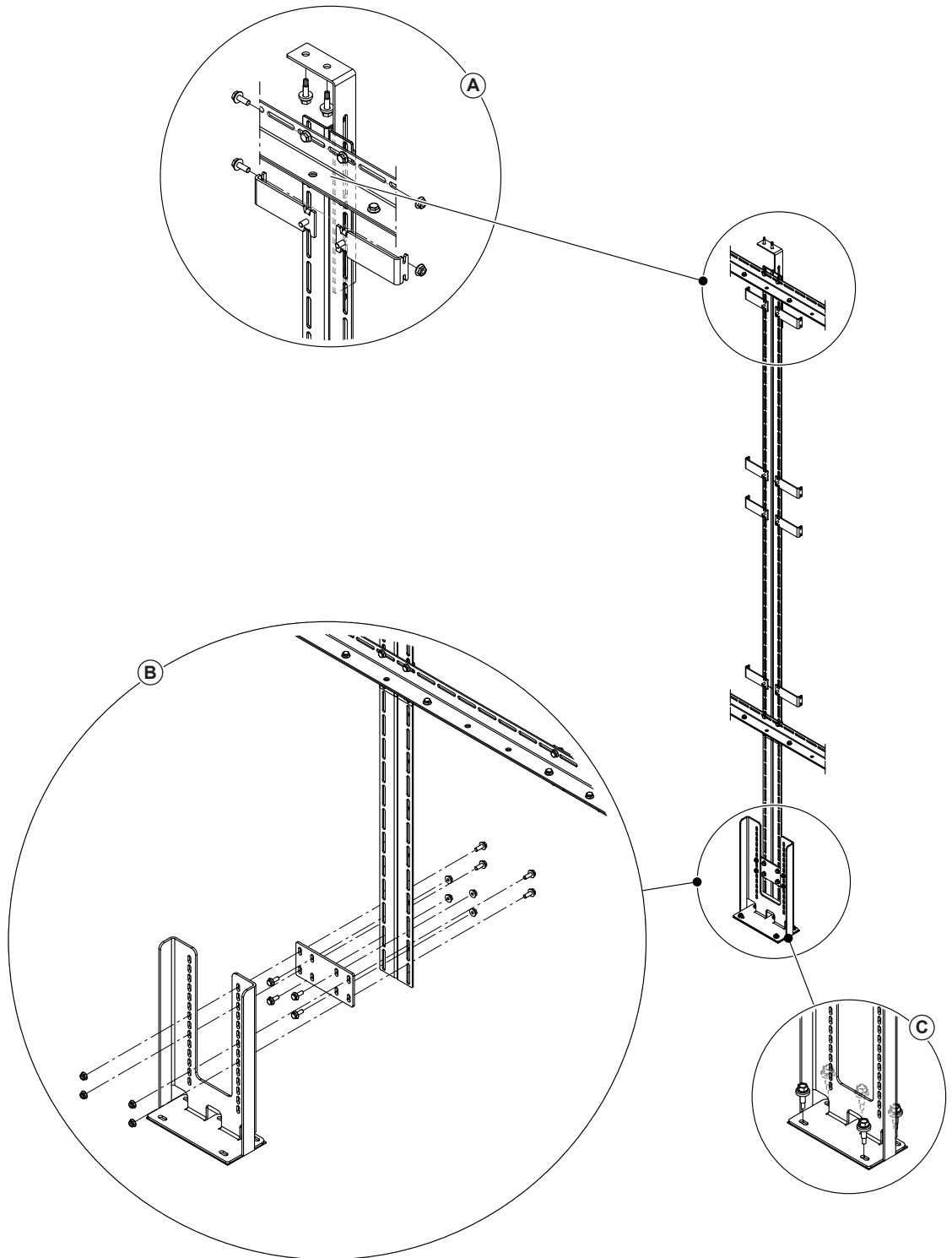

Fig. 29: Mounting the bottom leg support and the angle bracket to the middle vertical support

Note: in the duct section where the leg support is fixed to the duct/AHU floor (or tub) a reinforcement traverse may be installed where required. However, make sure the leg support does not stand in the water during operation. On ducts/AHU's with a tub divided in longitudinal direction the leg support may also be fixed to the tub partitionment if a sufficient load bearing capacity is assured.

- If necessary, loosen the two screw connections fixing the angle bracket to the vertical support, push angle bracket to the duct ceiling, then fasten the two screw connections again (see detail A in [Fig. 29](#)).
- Fix angle bracket of the vertical support(s) with two appropriate self-tapping screws to the duct ceiling (see detail A in [Fig. 29](#)).
- Fix fastening plate of the leg support at the appropriate position on the lower end to the vertical support with four screws M6 x 16 mm and nuts supplied. Slightly fasten the screw connections only (see detail A in [Fig. 29](#)).
- Fix leg support to the fastening plate with four screws M6 x 16 mm and nuts supplied. Slightly fasten the screw connections only (see detail B in [Fig. 29](#)).
- Shift the leg support down to the air duct/AHU floor, then fix the leg support to the traverse/ tub partitionment using five appropriate self-tapping screws (see detail C in [Fig. 29](#)).
Important: Before fastening the leg support to the duct/AHU floor make sure the lowermost cross member is flush over the entire duct width.
- Check dimensions again and realign if necessary. Then, tighten the screw connections on the leg support.

4. Mount the nozzle grid(s):

- Hang up nozzle grid into the holders, then push nozzle grid downwards until it comes to a stop. Repeat step for additional nozzle grid(s) if necessary.

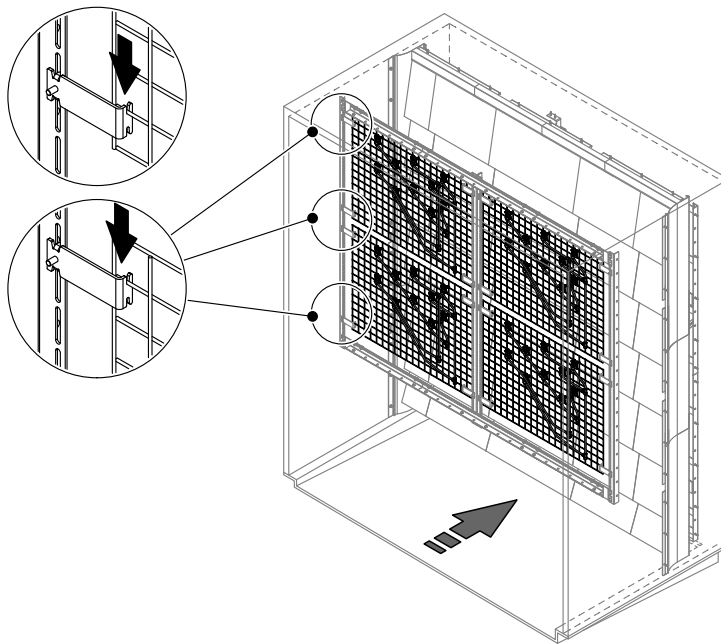

Fig. 30: Mounting the nozzle grid(s)

5. Mount housing feed throughs:

- Mark the required number of feed through holes (vertically or horizontally) on the duct wall using the drilling template supplied (7 steps: 3 feed through holes / 15 steps: 4 feed through holes / 31 steps: 5 feed through holes).

Important: The feed through holes must be below the lowest hose connector on the nozzle grid(s).

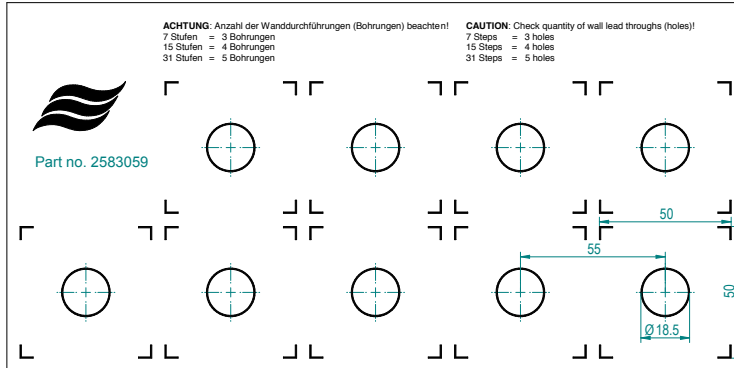

Fig. 31: Drilling template feed through holes

- Drill feed through holes $\varnothing 0.73$ " ($\varnothing 18.5$ mm) into the duct wall and deburr the holes.
- Insert housing feed throughs with gasket from the inside of the duct into the holes and fix them to the duct wall using two appropriate self-tapping screws.
- Screw in and fasten by hand hose connectors on both sides into the housing feed throughs.

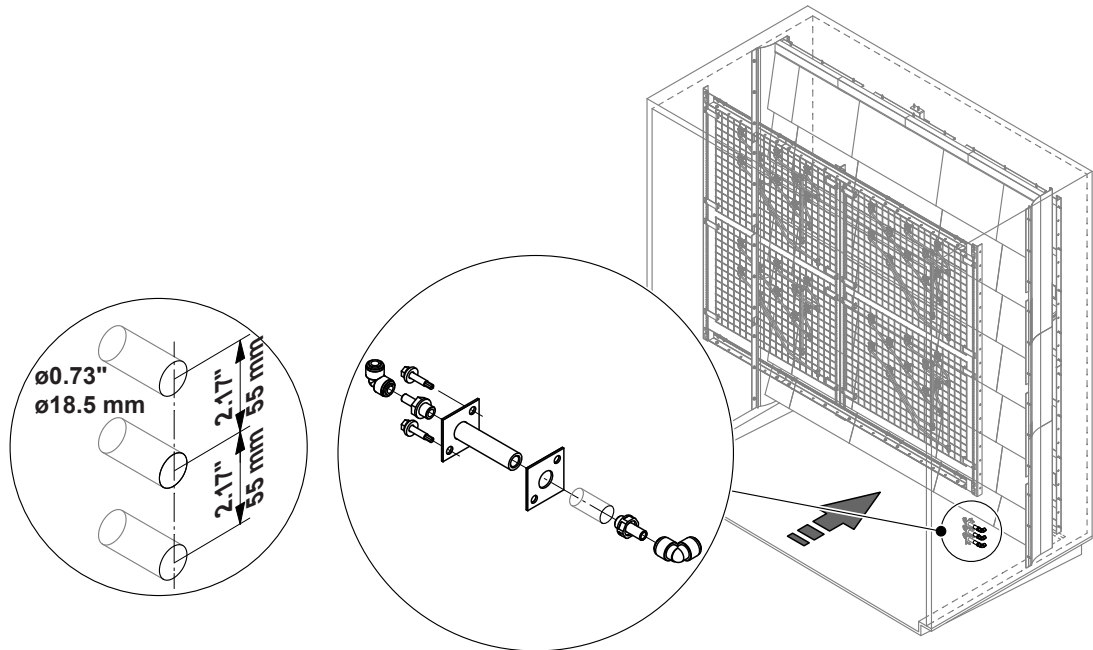

Fig. 32: Mounting the housing feed throughs

6. Connect spray circuits to the housing feed throughs:

- Interconnect the spray circuits of the different nozzle grids (if more than on grid is present). Interconnect spray circuits with same color only.
Important: Make sure the spray circuit lines have a minimum constant downslope of 2 % to the housing feed throughs.
- Connect spray circuits to the appropriate housing feed throughs.

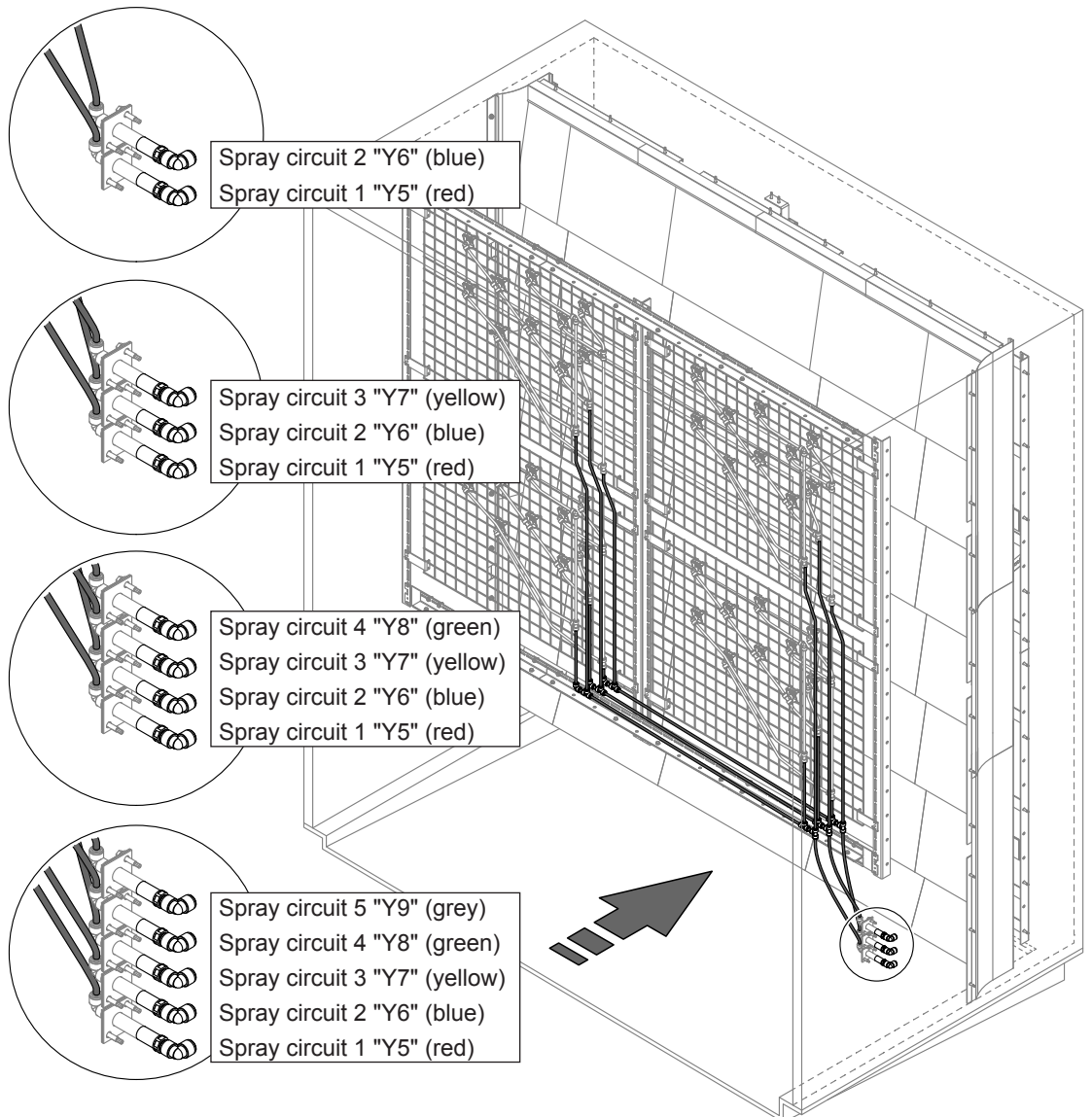

Fig. 33: Connecting spray circuits to the housing feed throughs

4.4 Positioning and mounting the control unit and central unit mounting rack

Positioning the mounting rack

- The mounting rack is designed for floor-mounting in interior spaces. Make sure that the floor surface on which the mounting rack is to be mounted, offers a **sufficient high load-bearing capacity and stability**, and is suitable for the installation.



CAUTION!

Do **not** mount the mounting rack on vibrating floors, not in exposed areas or places with excessive dust load.

- The central unit or the mounting rack, respectively may only be installed in rooms with a floor drain. If for some reason the central unit must be installed in a location without floor drain, it is mandatory to provide a leak monitoring device to safely interrupt the water supply in case of a leak. Additionally make sure that sensitive materials are kept clear of the central unit to prevent damage in case of a water leak.
- Make sure the room in which the mounting rack with the control unit and the central unit is mounted meets the following ambient conditions:
 - Ambient temperature: 41 ... 104 °F (5 ... 40 °C)
 - Ambient humidity: max. 80 %rh, not condensing
- Locate the mounting rack in such a manner that:
 - the length of the spray circuit lines between central unit and housing feed throughs of the duct are as short as possible (**max. 32.81 ft (10 m)**).
 - the spray circuit lines can be installed with a constant downslope (min. 2%) from the housing feed throughs on the duct/AHU to the connections of the central unit.
 - the central unit and the control unit which are mounted to the mounting rack are **freely accessible** with sufficient space available for maintenance purposes (**minimum clearances** showed in [Fig. 35](#) **must be adhered to**).
- The central unit and the control unit are protected according to **IP21**. Make sure the mounting rack is installed in a drip-proof location and the admissible ambient conditions are complied with.
- When fixing the mounting rack to the floor use **only the fixing materials supplied with the mounting rack**. If fixing with the materials supplied is not possible in your particular case, select a method of fixing that is of similar stability.

Assembling and fixing the mounting rack to the floor

1. Assemble the rack stands (1), mounting plates (4 and 5) and the brace (9) with the hexagon socket screws and washers supplied as shown in [Fig. 34](#). Tighten all screws.

Note: mounting plate (5) may be mounted in three different heights.

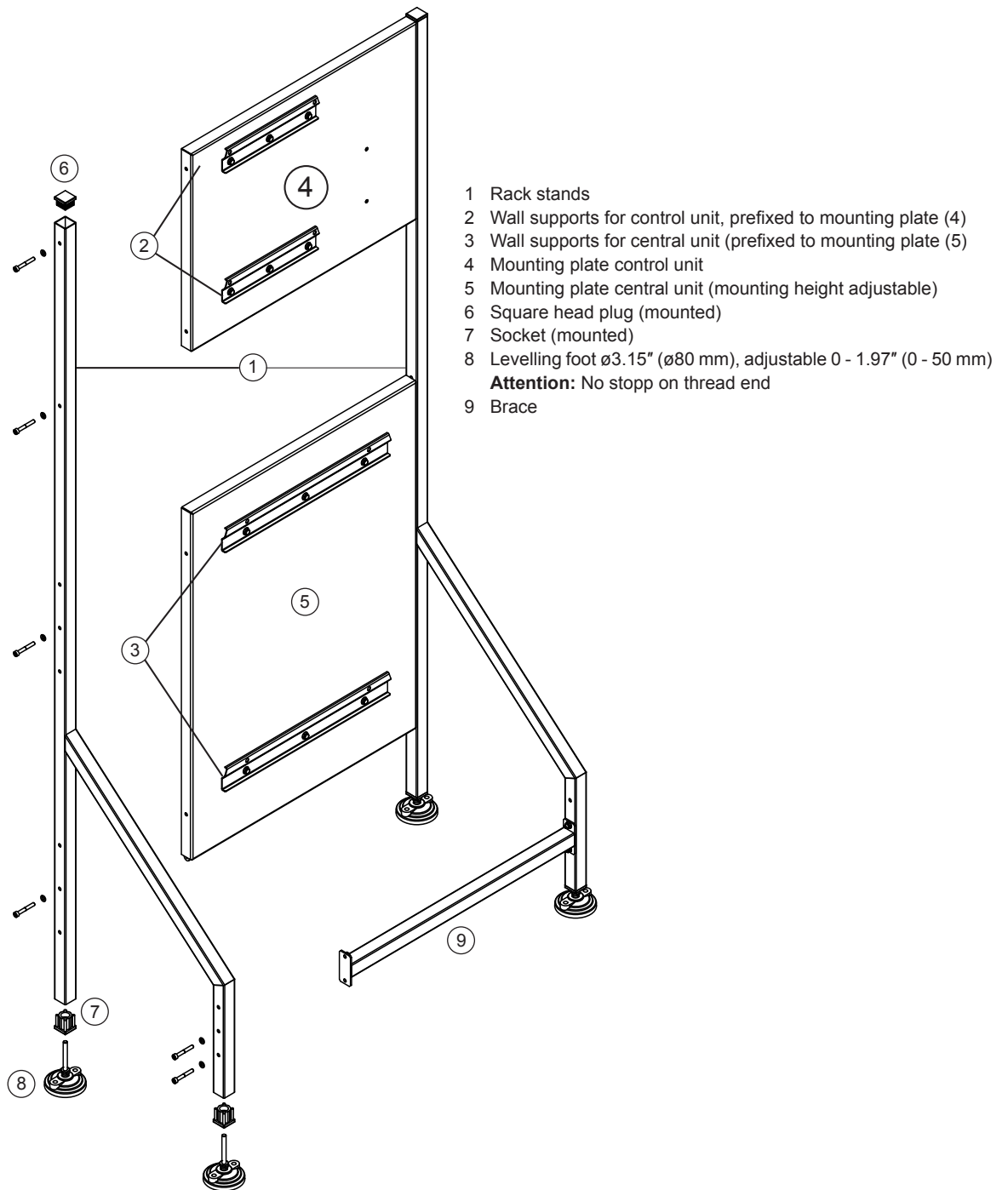

Fig. 34: Assembling the mounting rack

2. Insert levelling feet into the sockets (7).
3. Place mounting rack at the desired position.

Note: Ensure the positioning requirements and minimal clearances are observed.

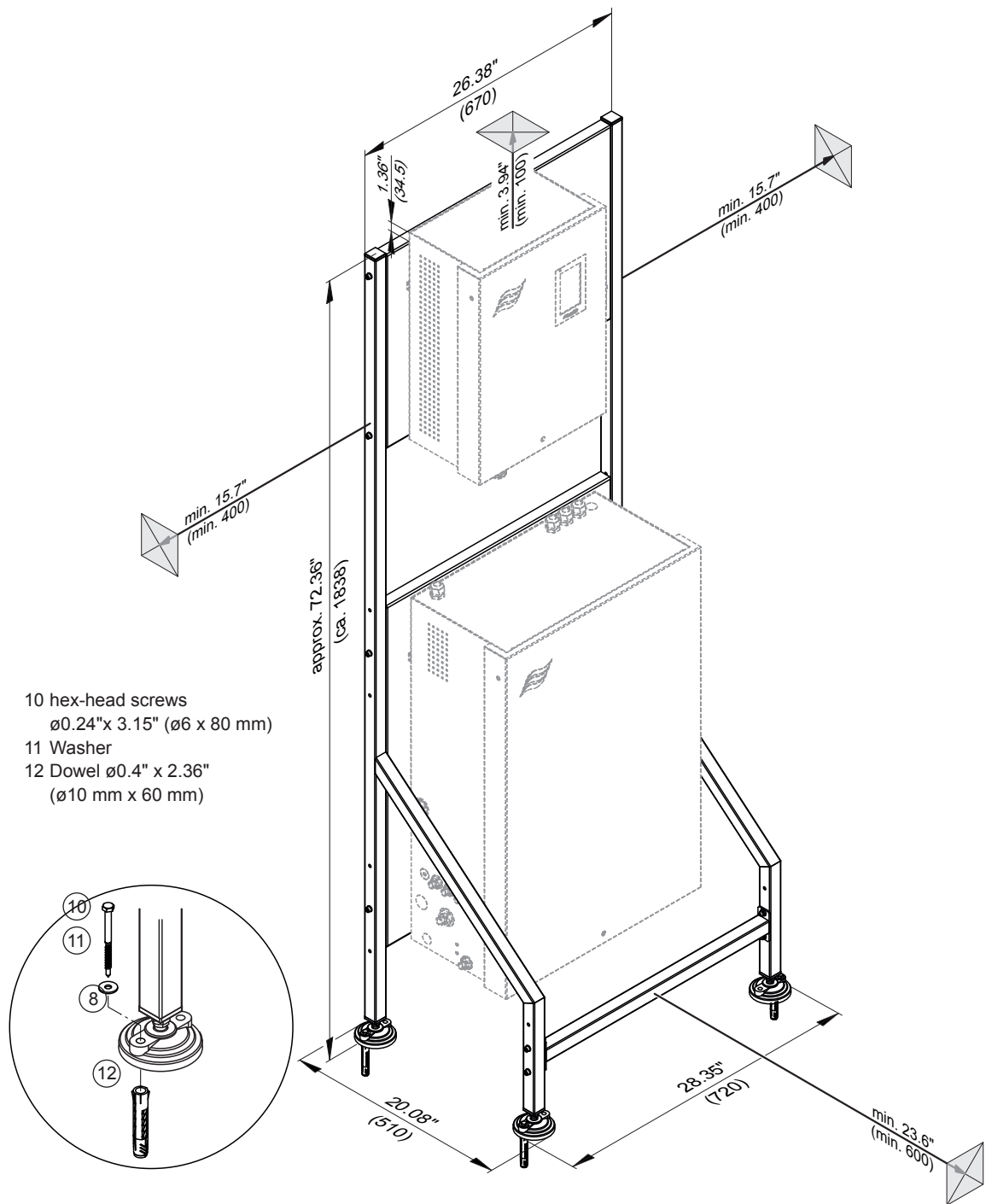

Fig. 35: Fixing the mounting rack to the floor- dimensions in Inch (mm)

4. Adjust mounting rack vertically and horizontally with the help of the levelling feet (8) a spirit level.
5. Mark one fixing hole on each levelling foot. Then, drill holes ø4" (ø10 mm), 2.36" (60 mm) deep into the floor.
6. Remove mounting rack. Insert dowels ø0.4" x 2.36" (ø10 mm x 60 mm) into the bores. Reposition the mounting rack.
7. Fix levelling feet to the floor using the and fix it to the floor using the hex-head screws ø0.24" x 3.15" (ø6 x 80 mm) and washers supplied.
8. Check vertical and horizontal alignment of the mounting rack and realign if necessary. Tighten the counter nuts on all levelling feet.
9. Make sure all screw connections on the mounting rack are fastened.

4.5 Converting the spray circuit outlets from left to right

Ex factory the central unit is delivered with spray circuit outlets on the left side. If, for site specific reasons the spray circuit outlets must be on the right unit side the spray circuits can be repositioned as follows:

1. Disconnect spray circuit hoses inside the central unit from the valve block and the outlet connectors.
2. Remove outlet connectors on the left unit side and close holes with the plugs from the left side.
3. Fix outlet connectors at the appropriate positions into the holes on the right unit side.
4. Connect spray circuit hoses to the valve block and the outlet connectors inside the central unit according to the corresponding figure in the following table.

Important: Make sure to place the colored rings to the appropriate spray line.

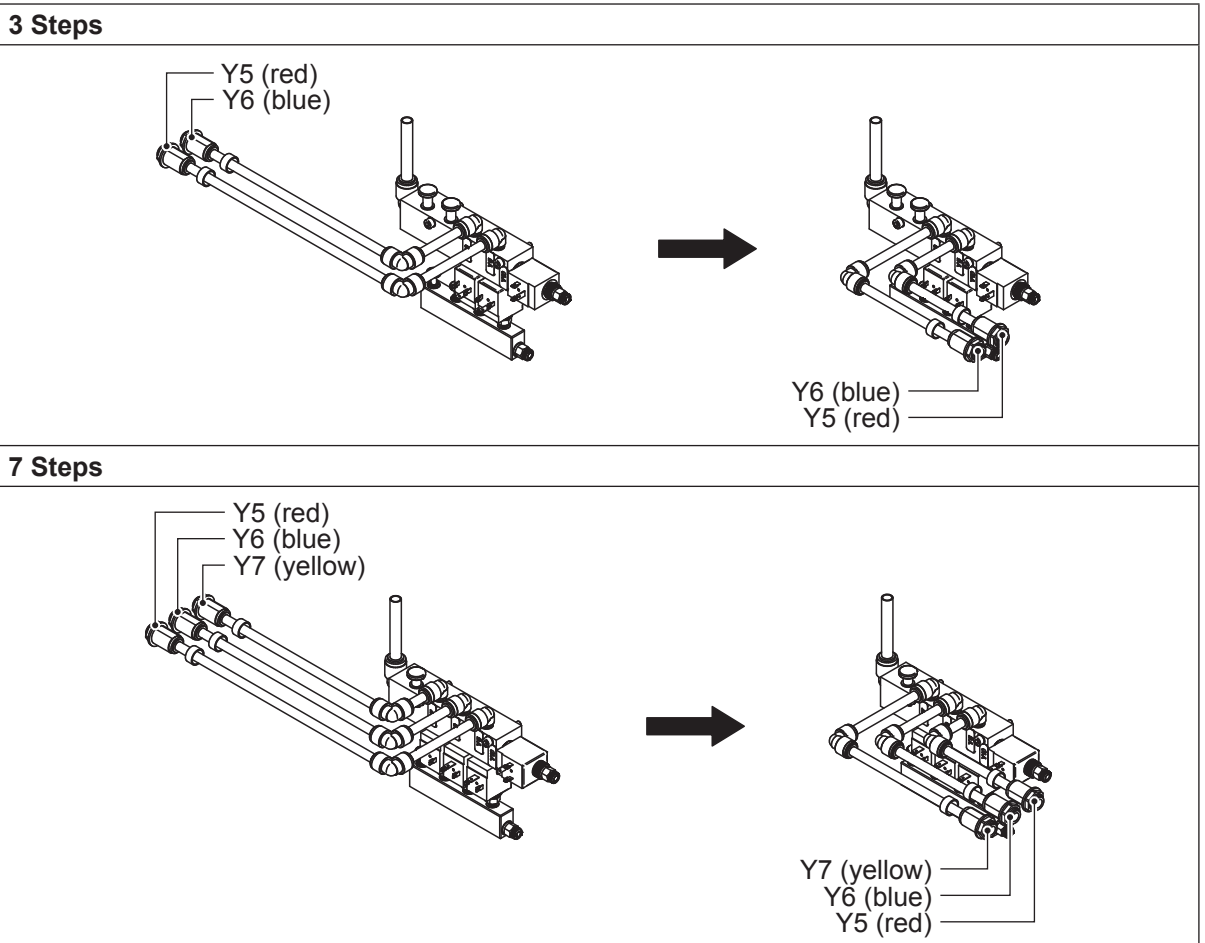

7 Steps with double stage

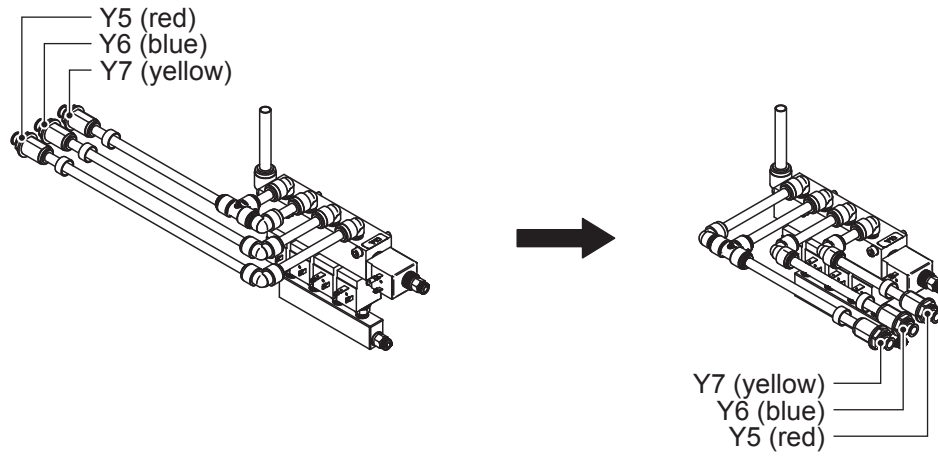

15 Steps

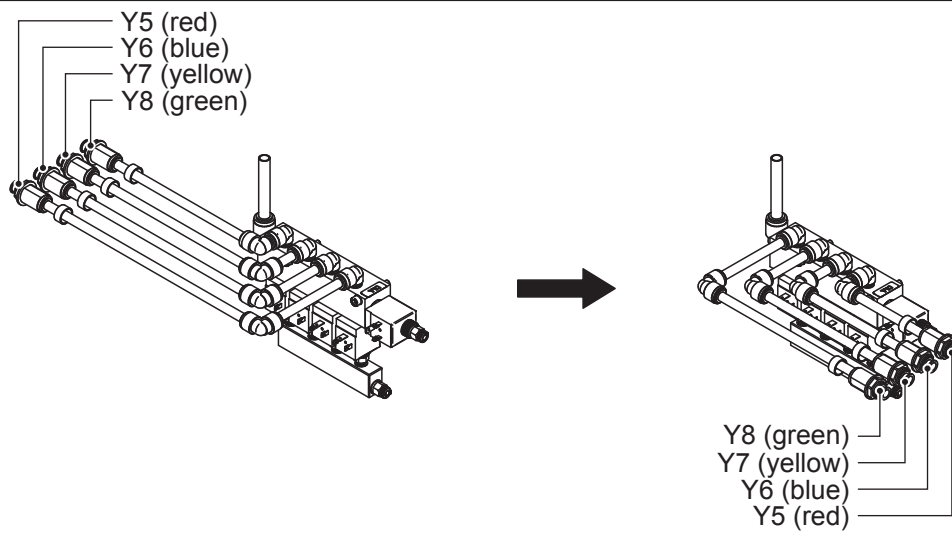

15 Steps with double stage

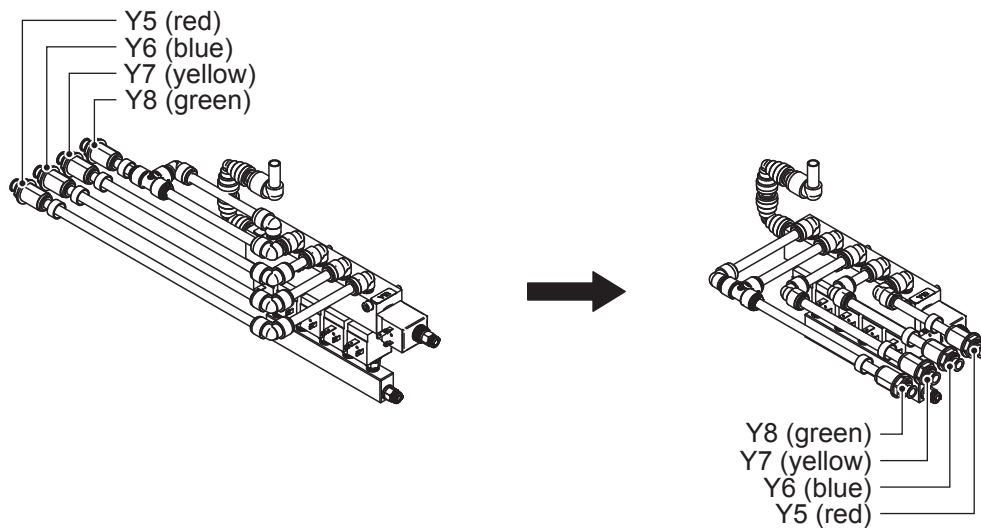

31 Steps

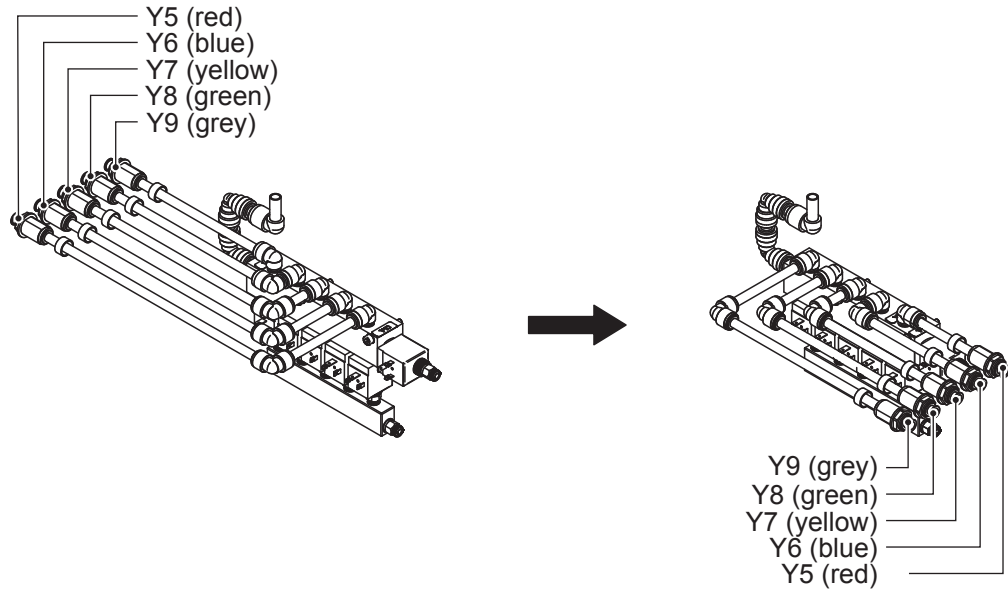

31 Steps with double stage

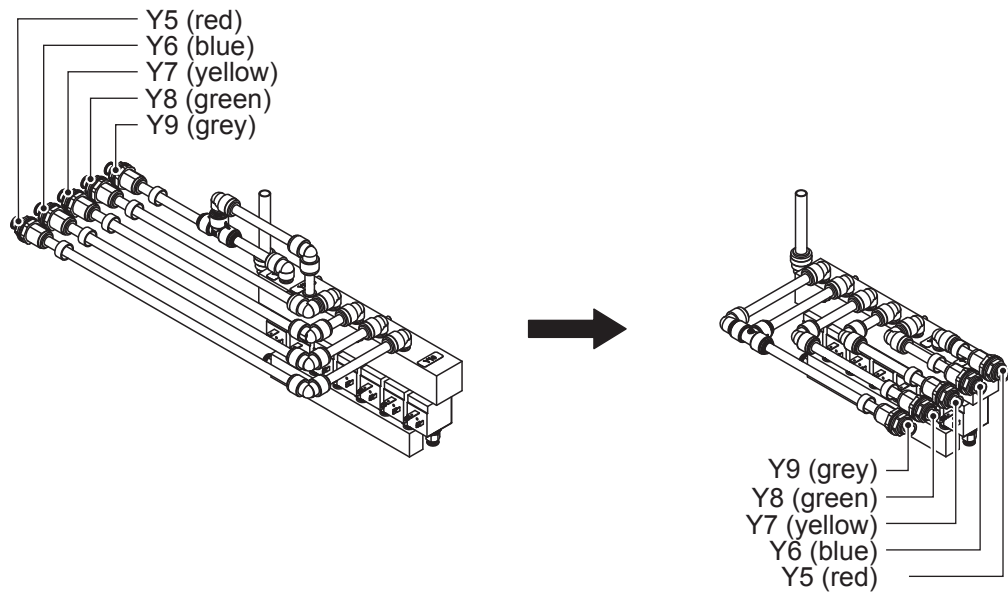

4.6 Mounting the central unit to the mounting rack

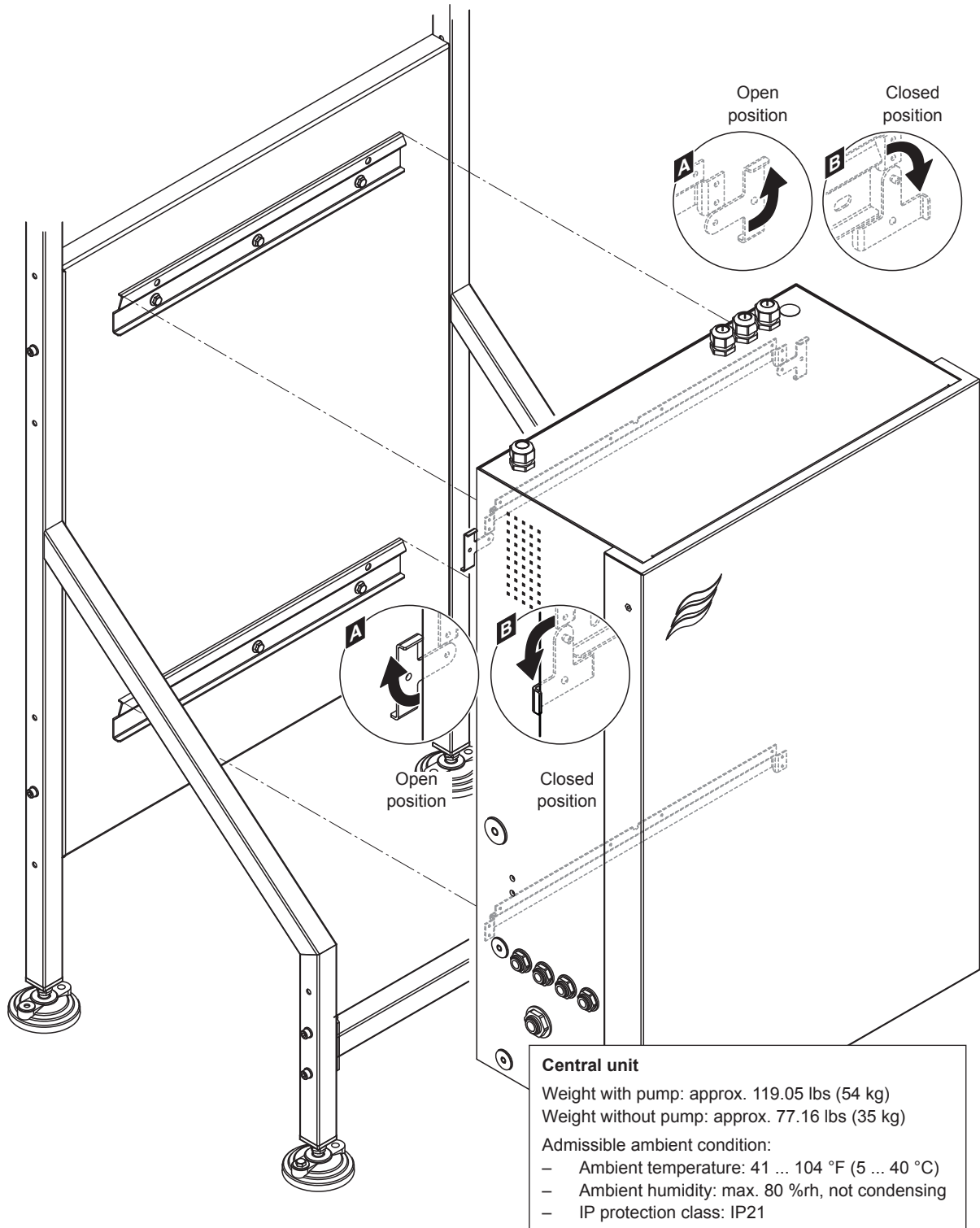

Fig. 36: Mounting the central unit to the mounting rack - dimensions in Inch (mm)

1. Move the locking hooks on the back of the central unit to open position (see [detail "A" in Fig. 36](#)).
2. Hang up the central unit onto the wall supports.
3. Move the locking hooks on the back of the central unit to closed position (see [detail "B" in Fig. 36](#)) in order to fix the central unit to the upper wall support.

4.7 Mounting the control unit to the mounting rack

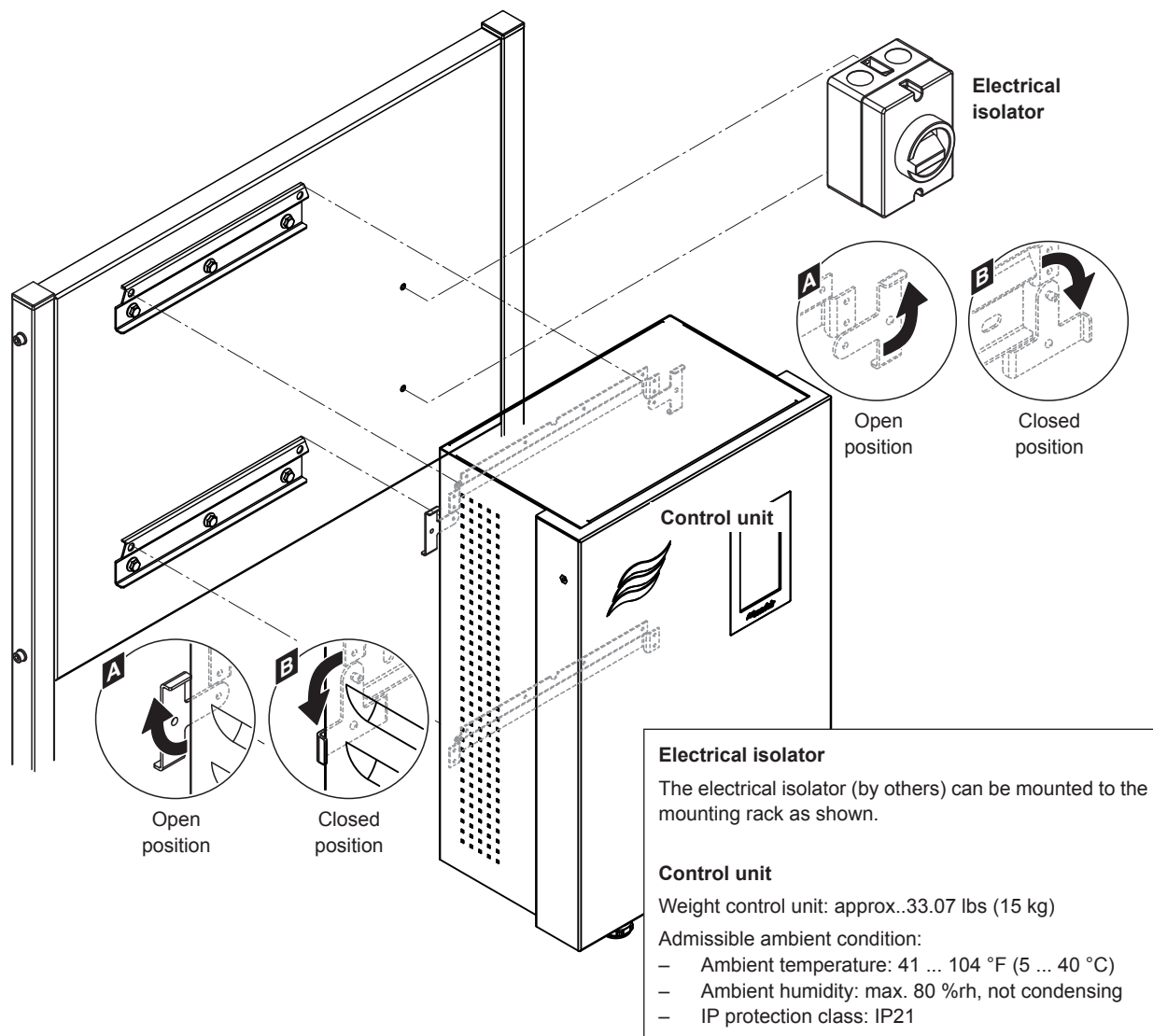

Fig. 37: Mounting the control unit - dimensions in Inch (mm)

1. Move the locking hooks on the back of the control unit to open position (see [detail "A" in Fig. 37](#)).
2. Hang up the control unit onto the wall supports.
3. Move the locking hooks on the back of the control unit to closed position (see [detail "B" in Fig. 37](#)) in order to fix the control unit to the upper wall support.

4.8 Water installation

4.8.1 Overview water installation

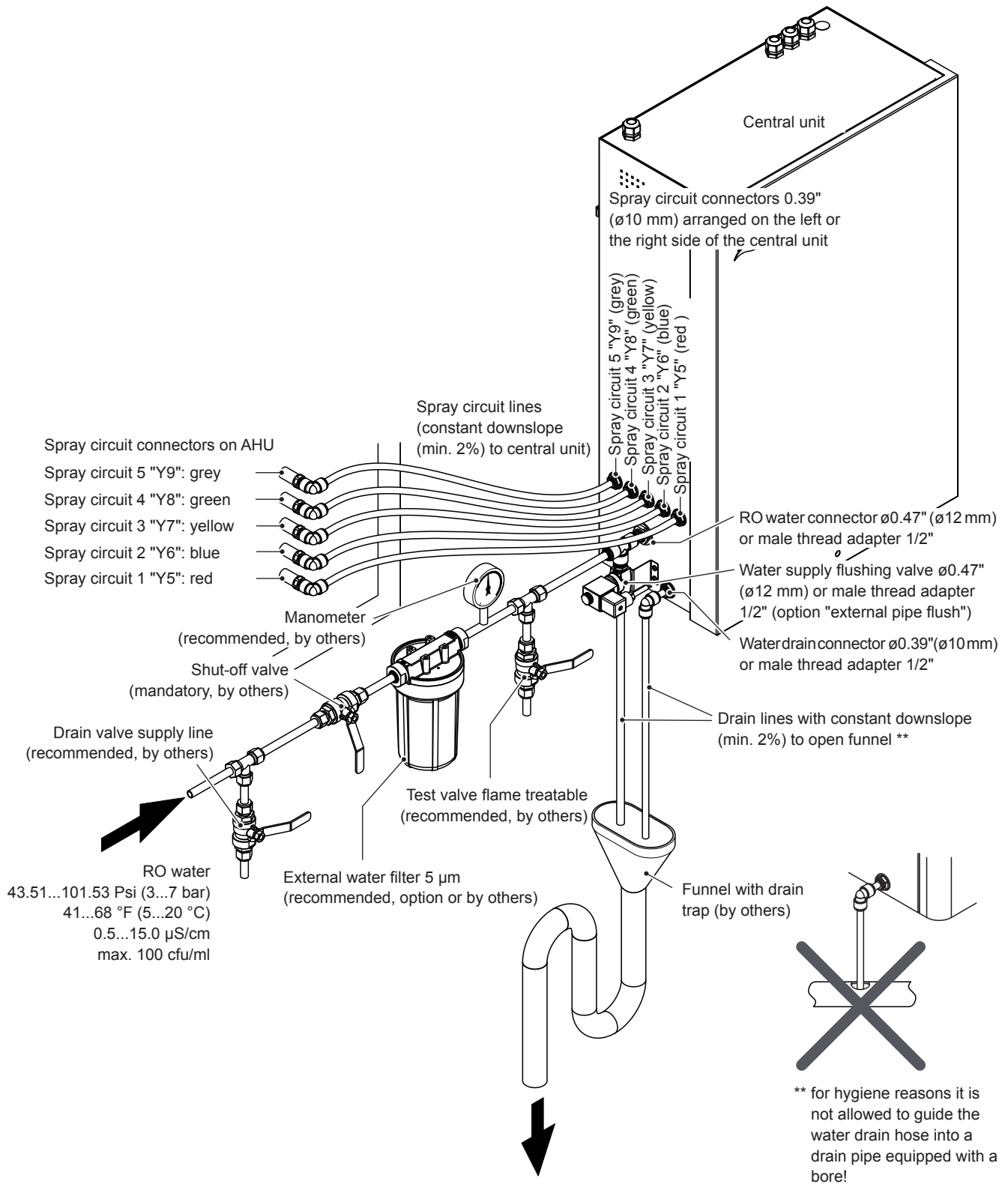

Fig. 38: Overview water installation

4.8.2 Notes on water installation

General notes on installation of the hoses

- Use the supplied black plastic hoses $\varnothing 0.39"/0.31"$ ($\varnothing 10/8$ mm) and $\varnothing 0.47"/0.35"$ ($\varnothing 12/9$ mm) only. For hygienic reasons do not use other hoses (except products supplied by your Condair distributor).



CAUTION!

Fully demineralized water is aggressive. For this reason, the entire water system must contain **fully demineralized water resistant material only** (e.g. do not use copper pipes).

- When cutting hoses use an **appropriate cutting tool** providing **straight, kink-free** cuts.



CAUTION!

After cutting the tubes the **sharp cutting edge must be deburred** otherwise the couplings may be damaged.

- The hoses must be free of kinks and other damage (longitudinal scratches, in particular).
- When cutting hoses always **add at least 0.2" (5 mm)** to the required length. This way the hoses can be fastened correctly (down to the stop) to the quick-action couplings of the nipples.
- Make sure the hoses are not kinked and pay attention to the **minimum bend radius of 3.94" (100 mm)**.
- Do not lead hoses past hot system components (**max. ambient temperature is 104 °F (40 °C)**).
- To prevent damage we strongly recommend leading the hoses inside a duct (or a similar means of protection) between the central unit and the housing feed throughs of the duct/AHU.
- It is mandatory that the hoses between the connections on the nozzle grid and the housing feed throughs on the duct/AHU, and between the housing feed throughs and the corresponding connectors on the central unit are installed with a constant downslope.
- After installation verify correct fastening of all hoses. Correctly mounted hoses can not be removed without pressing the locking ring.



CAUTION!

In order to avoid damage caused by leaking water during operation, all hoses must correctly be secured against accidentally pulling out.

RO water supply

- The water supply line is to be connected either directly or via the supplied 1/2" male thread adapter to the 0.47" ($\varnothing 12$ mm) water supply connector on the left side of the central unit. The installation of a **shut-off valve is mandatory**. The shut-off valve is to be installed as close to central unit as possible. The installation of a water supply drain valve, a water filter with a mesh width of min. 0.005 mm and a test valve is recommended.

Before joining the RO water supply line to the water supply connector on the central unit, **flush the supply line thoroughly for at least 10 minutes**.

If the water pressure is >101.53 psi (>7 bar), install a pressure reducing valve (set to 101.53 psi (7 bar) in the supply line.

- If the length of the water supply line between the water conditioning unit and the central unit of the Condair DL exceeds 65.62 ft (20 m), the supply line must be equipped with a suitable pressure damper (overflow valve, surge tank, etc.). Furthermore, the supply line must be properly fastened according to the regulations
- The RO water must meet the following requirements:
 - **Fully demineralized water from a reverse osmosis system**
 - **Conductivity of the supply water: 0.5 ... 15.0 µS/cm**
 - **Working pressure at maximum humidification capacity: min. 43.51 psi (3 bar)**
 - **Maximum admissible inlet temperature: 68 °F (20 °C)**
 - **No additives** (such as **chlorine, disinfecting agents, ozone**, etc.) , except such approved by Condair.
 - **Max. germ count at the water inlet** on the Condair DL: **100 cfu/ml**

Water drain line central unit

The water drain line is to be connected either directly or via the supplied 1/2" male thread adapter to the ø0.39" (ø10 mm) water drain connector on the left side of the central unit.

The water drain line is led from the central unit with a constant downslope (min 2%) down into an open funnel connected via a siphon to waste water line of the building.

Important: for hygiene reasons, the water drain line of the central unit must under no circumstances be combined together with other drain lines before of the open funnel, but must be routed separately to the open funnel. The drain line must not touch the funnel and other drain lines, an air gap of min. 0.8" (2 cm) must be maintained.

Prevent the water drain line from slipping out of the funnel by fastening it **with appropriate means right above the funnel** (without reducing the diameter of the hose).

Important: for hygiene reasons it is not allowed to guide the water drain hose into a drain pipe equipped with a bore!

Water drain line of the external pipe flush option

The water drain line of the external pipe flush option is to be connected either directly or via the supplied 1/2" male thread adapter to the ø0.47" (ø12 mm) water drain connector of the external water supply flushing valve on the left side of the central unit.

Important: The same regulations apply to the routing of the water drain line of the external pipe flush option as to the water drain line of the central unit (see above).

4.9 Electrical installation

4.9.1 Notes on electrical installation



DANGER!
Danger of electric shock

The control unit of the Condair DL and the pump motor inside the central unit (if applicable) are mains powered. Live parts may be exposed when the control unit and/or the central unit is/are open. Touching live parts may cause severe injury or danger to life.

Prevention: The control unit of the Condair DL must be connected to the mains only after all mounting and installation work has been completed, all installations have been checked for correct workmanship and all unit covers are relocated properly locked.

Important! The frequency converter in the control unit of systems with booster pump contains capacitors. These can remain charged with a potentially deadly voltage for a certain period of time after the control unit has been disconnected from the power supply. Therefore, wait at least 10 minutes after disconnecting the power supply. Then make sure the appropriate contacts on the frequency converter and the terminals on the pump motor are free of voltage before starting any work on these components!



CAUTION!

The electronic components inside the control unit are very sensitive to electrostatic discharge. Before carrying out installations work inside the control unit, appropriate measures must be taken to protect the electronic components against damage caused by electrostatic discharge (ESD protection).

- All work concerning the electrical installation must be performed only by **skilled and qualified technical personnel (e.g. electrician with appropriate training) authorized by the owner**. It is the owner's responsibility to verify proper qualification of the personnel.
- The electrical installation must be carried out according to the wiring diagrams [Section 4.9.2](#), the notes on electrical installation as well as the applicable local regulations. All information given in the wiring diagram must be followed and observed.
- All cables must be lead into the control unit, the central unit and the electrical isolator via appropriate cable feed throughs.
- Make sure the cables are adequately fixed, do not contact any other components, or become a stumbling hazard.
- Observe and maintain maximum cable length and required cross section per wire according to local regulations.
- The mains supply voltage must match the respective voltage stated on the type plate.

4.10 Wiring plan Condair DL

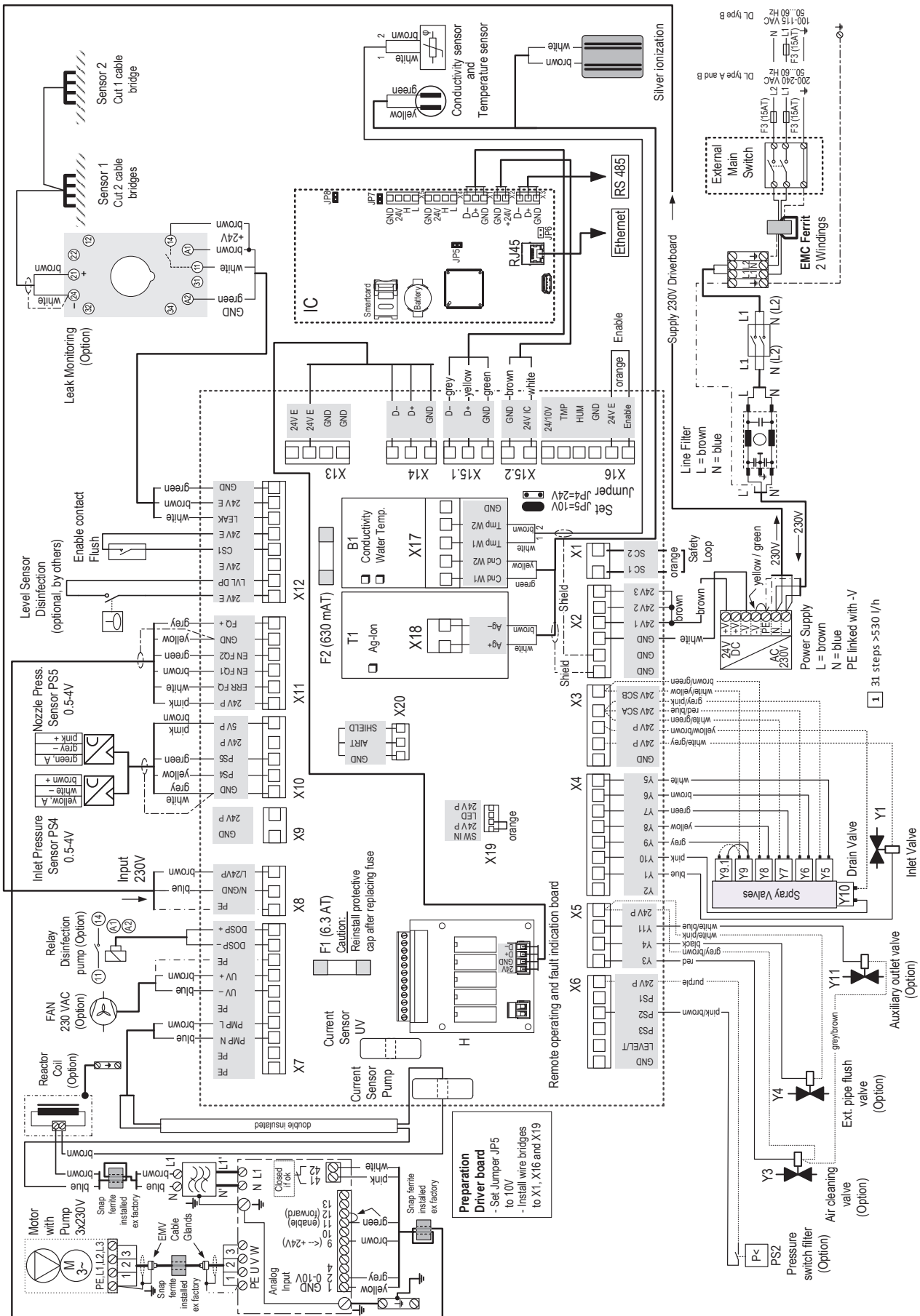

Fig. 40: Wiring plan Condair DL

4.10.1 Electrical connections between central unit and control unit

4.10.1.1 Wiring diagram central unit - control unit

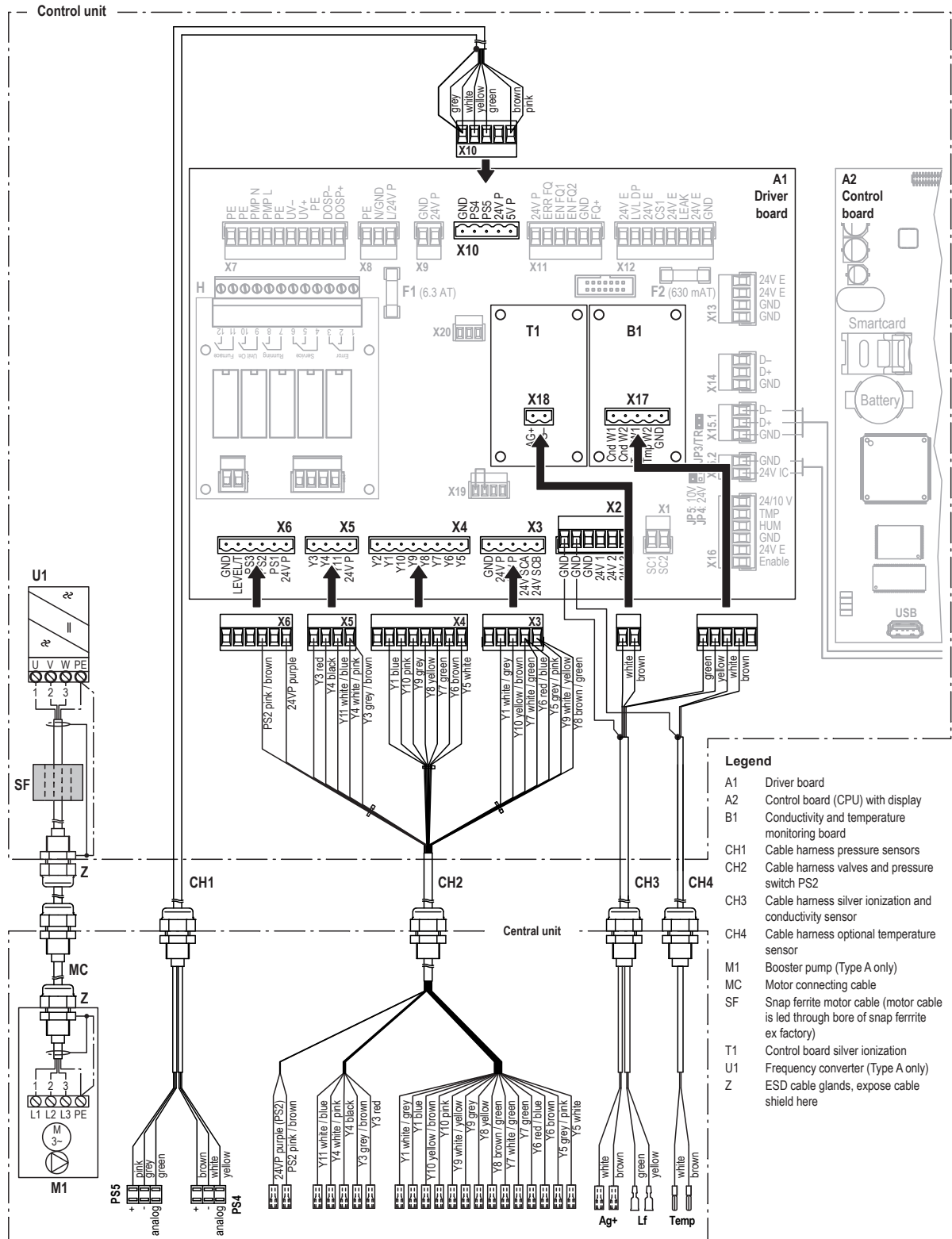
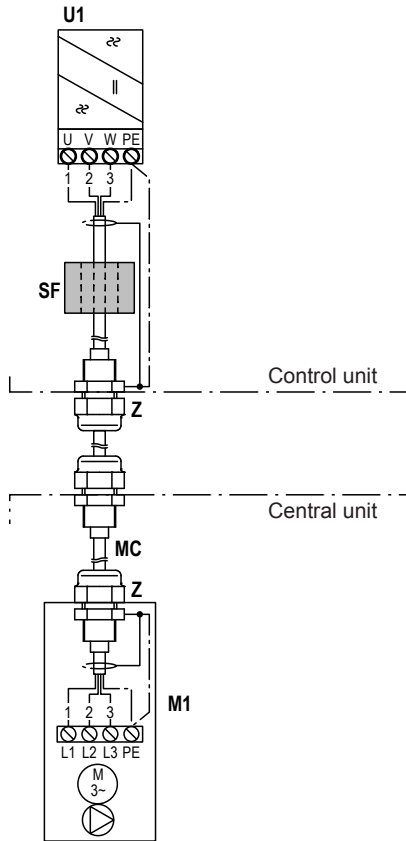

Fig. 41: Wiring diagram central unit - control unit

4.10.1.2 Installation work central unit - control unit

Connecting the motor cable (MC) to the frequency converter (type A only)

Danger of electric shock! The frequency converter in the control unit of systems with booster pump contains capacitors. These can remain charged with a potentially deadly voltage for a certain period of time after the control unit has been disconnected from the power supply. Therefore, wait at least 10 minutes after disconnecting the power supply. Then make sure the appropriate contacts on the frequency converter and the terminals on the pump motor are free of voltage before starting any work on the electrical wiring!



Ex factory the pre-fabricated motor cable is connected to the frequency converter inside control unit. On site the motor cable must be fed via the cable gland (top left) into the central unit, and there be connected to the booster pump motor according to the wiring diagram. The exposed shielding of the motor cable must be placed in the metallic EMV cable gland (Z) so that it has contact with the cable gland (see figure below).

Note: the remaining cable between control and central unit must be pulled down into the central unit and there be inserted in a loop into the corresponding cable duct.

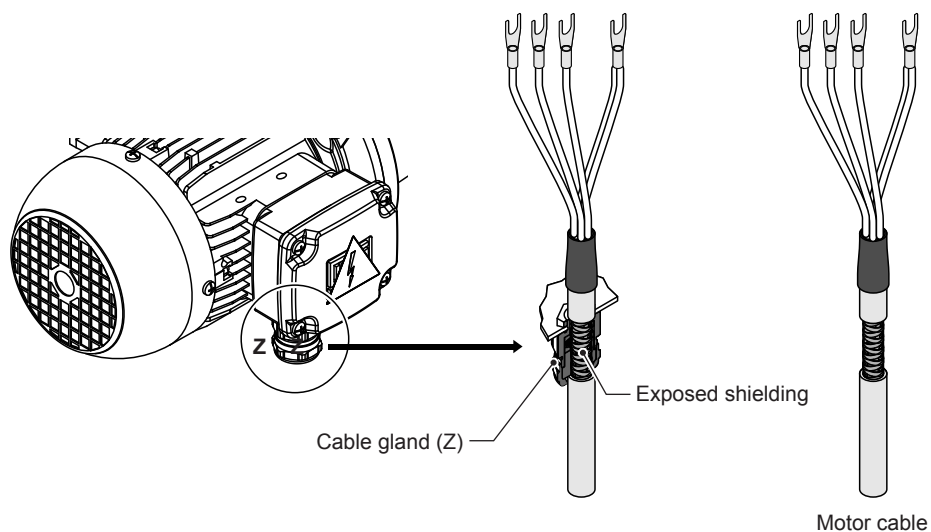

Connecting the cable harness "CH1" (Pressure sensors)

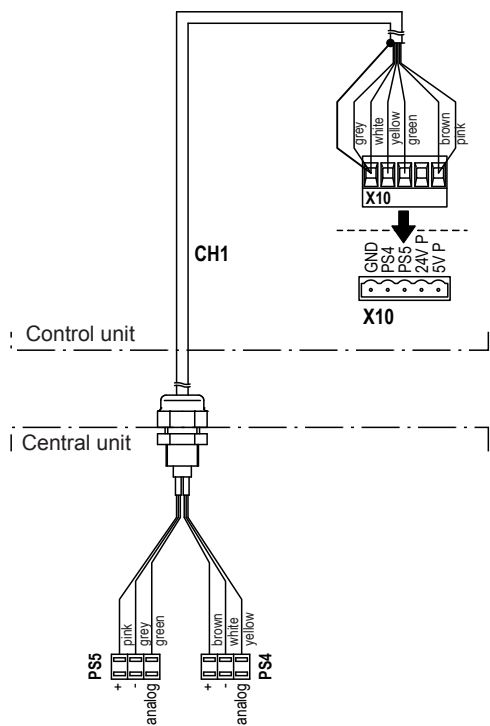

Ex factory the cable harness "CH1" (Pressure sensors) is connected inside central unit to the corresponding pressure sensors. On site the terminal connector of the cable harness must be connected to the appropriate terminal (X10) on the driver board inside the control unit. The cable harness is to be led through the rectangular cable feed through into the control unit.

Note: lead cable harness inside the control unit in the cable ducts to the corresponding terminal on the driver board as shown below. The remaining cable of the cable harness between control and central unit must be pulled down into the central unit and there be inserted in a loop into the corresponding cable duct.

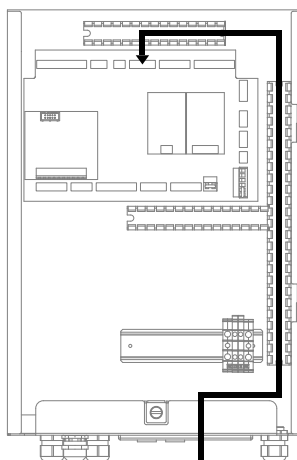

Connecting the cable harness "CH2" (Valves)

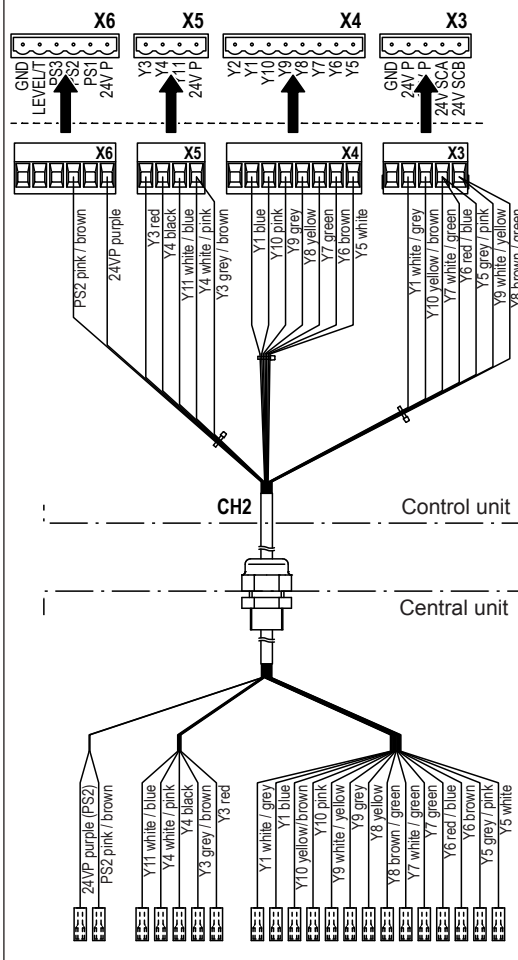

Ex factory the cable harness "CH2" (Valves) is connected inside central unit to the corresponding valves. On site the terminal connectors of the cable harness must be connected to the appropriate terminals (X3 to X6) on the driver board inside the control unit.

The cable harness is to be led through the rectangular cable feed through into the control unit

Note: lead cable harness inside the control unit in the cable ducts to the corresponding terminals on the driver board as shown below. The remaining cable of the cable harness between control and central unit must be pulled down into the central unit and there be inserted in a loop into the corresponding cable duct.

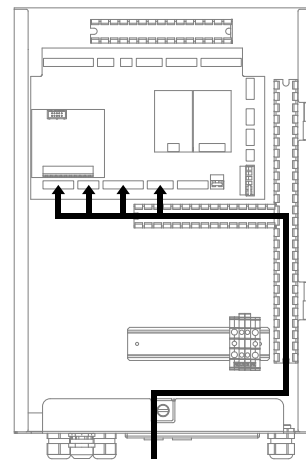

Connecting the cable harness "CH3" (silver ionization "Ag+" and conductivity sensor "Lf") and the cable harness "CH4" (optional temperature sensor)

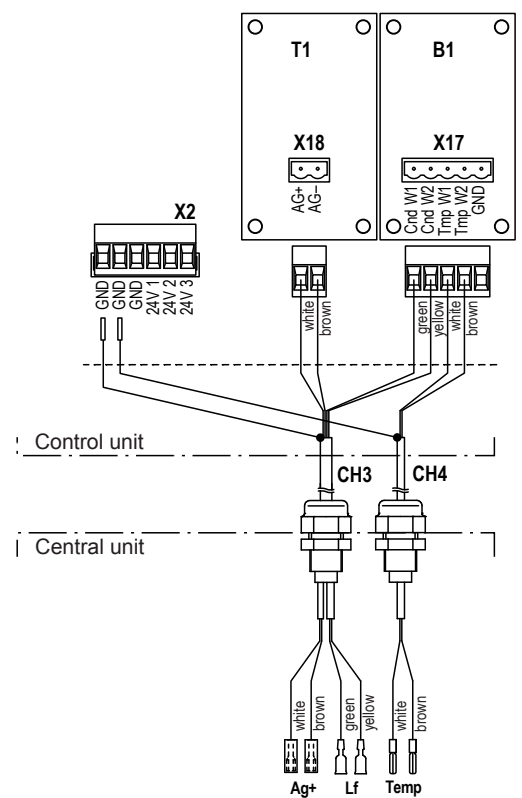

Ex factory the cable harness "CH3" (silver ionization "Ag+" and conductivity sensor "Lf") and the cable harness "CH4" (optional temperature sensor "Temp") are connected inside central unit to the silver ionization cartridge, to the conductivity sensor and to the temperature sensor (optional). On site the terminal connectors of the cable harnesses must be connected to the appropriate terminals on the silver ionization board (X18) and on the conductivity and temperature monitoring board (X17) inside the control unit.

The shielding of the cable harnesses must be connected to the corresponding "GND" terminals on terminal block "X2".

The cable harnesses are to be led through the rectangular cable feed through into the control unit.

Note: lead cable harnesses inside the control unit in the cable ducts to the corresponding terminals of the two boards as shown below. The remaining cable of the cable harnesses between control and central unit must be pulled down into the central unit and there be inserted in a loop into the corresponding cable duct.

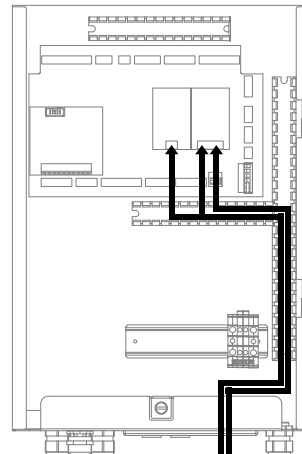

4.10.2 External electrical connections

4.10.2.1 Wiring diagram external electrical connections

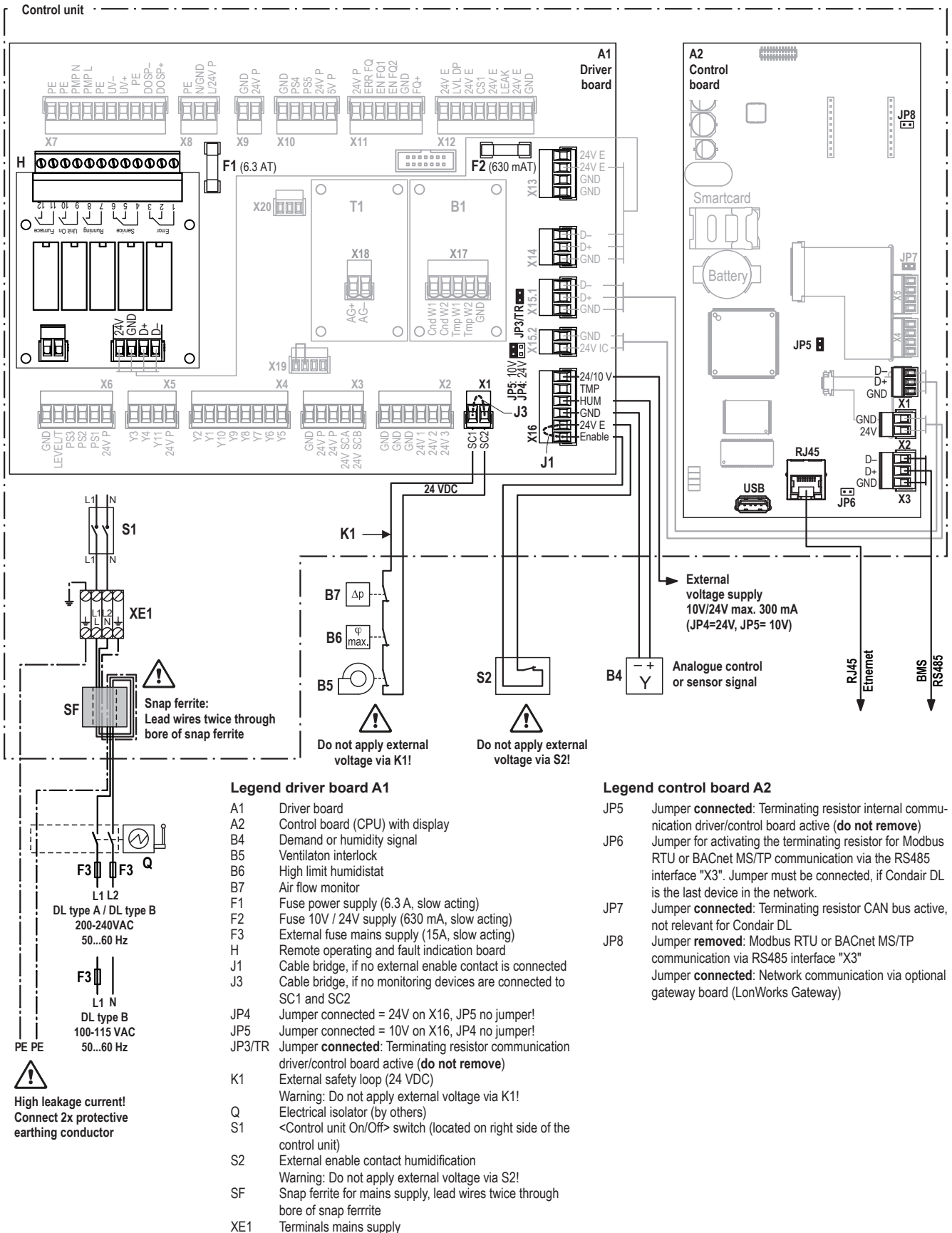
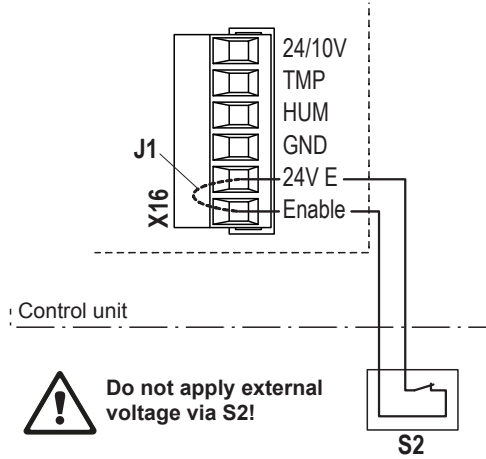

Fig. 42: Wiring diagram external electrical connections

4.10.2.2 Installation work external connections

Connecting the external safety loop	
<p>Control unit</p> <p>Do not apply external voltage via K1!</p> <p>24 VDC</p> <p>X1</p> <p>J3</p> <p>SC1</p> <p>SC2</p> <p>K1</p> <p>B7 Δp</p> <p>B6 φ max.</p> <p>B5</p>	<p>The potential-free contacts of external monitoring devices (e.g. ventilation interlock, safety high limit humidistat, air flow monitor, etc.) are connected in series (safety loop "K1") to the terminals "SC1" and "SC2" of the terminal block "X1" on the driver board in accordance with the wiring diagram.</p> <p>The connecting cable must either be led through the rectangular cable feed through or a free cable gland into the control unit.</p> <p>Note: If, for whatever reason, no external monitoring devices are connected, a cable bridge "J1" must be installed on the contacts "SC1" and "SC2" of the terminal block "X1".</p> <p>CAUTION! Do not apply any external voltage to contacts "SC1" and "SC2" via the contacts of the external monitoring devices.</p>
Connecting a demand or humidity signal	
<p>Control unit</p> <p>JP5: 10V</p> <p>JP4: 24V</p> <p>X16</p> <p>24/10V</p> <p>TMP</p> <p>HUM</p> <p>GND</p> <p>24V E</p> <p>Enable</p> <p>Y 10V/24V</p> <p>B4</p>	<p>The signal cable of an external controller or of a humidity sensor (if the internal P/PI controller is used) are to be connected according to the wiring diagram to the terminals "HUM" and "GND" of the terminal block "X16". The admissible signal values can be found in the technical data table in the operation manual. The connecting cable must either be led through the rectangular cable feed through or a free cable gland into the control unit.</p> <p>Note: if the external controller or the humidity sensor shall be supplied with 10 V or 24 V from the driver board (terminal "24/10V"), the corresponding jumper ("JP5: 10V" or "JP4: 24V") must be set and the other one must be removed.</p> <p>The shielding of the control signal cable must be connected to terminal "GND".</p> <p>Caution! If the shielding of the control signal is already connected to a potential or a grounded conductor, do not connect it to terminal "GND"</p>

Connecting the external enable switch



The potential-free contact of external enable contact is connected to the terminals "24V" and "Enable" of the terminal block "X16" on the driver board in accordance with the wiring diagram.

The connecting cable must either be led through the rectangular cable feed through or a free cable gland into the control unit.

CAUTION! Do not apply any external voltage to terminals via the external enable switch.

Connecting the remote operating and fault indication

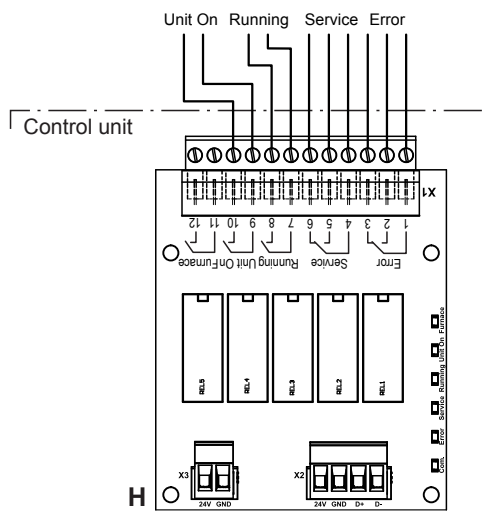

The connection of the error relay is mandatory in order that the Condair DL can signalize any malfunctions!

The remote operating and fault indication board contains four potential-free relay contacts for the connection of the following operating and fault indications:

- "Error" (Terminal 1 and 2/3):
This relay is activated if an error is present.
- "Service" (Terminal 4 and 5/6):
This relay is activated when the set service interval has expired.
- "Running" (Terminal 7 and 8):
This relay closes as soon as the Condair DL humidifies.
- "Unit on" (Terminal 9 and 10):
This relay closes as soon as the voltage supply to the control unit of the Condair DL is switched on.
- "Furnace":
This relay is not supported.

The connecting cable must either be led through the rectangular cable feed through or a free cable gland into the control unit.

The **maximum contact loading is 250V/8A.**

Appropriate suppressor modules are to be used for the switching of relays and miniature contactors.

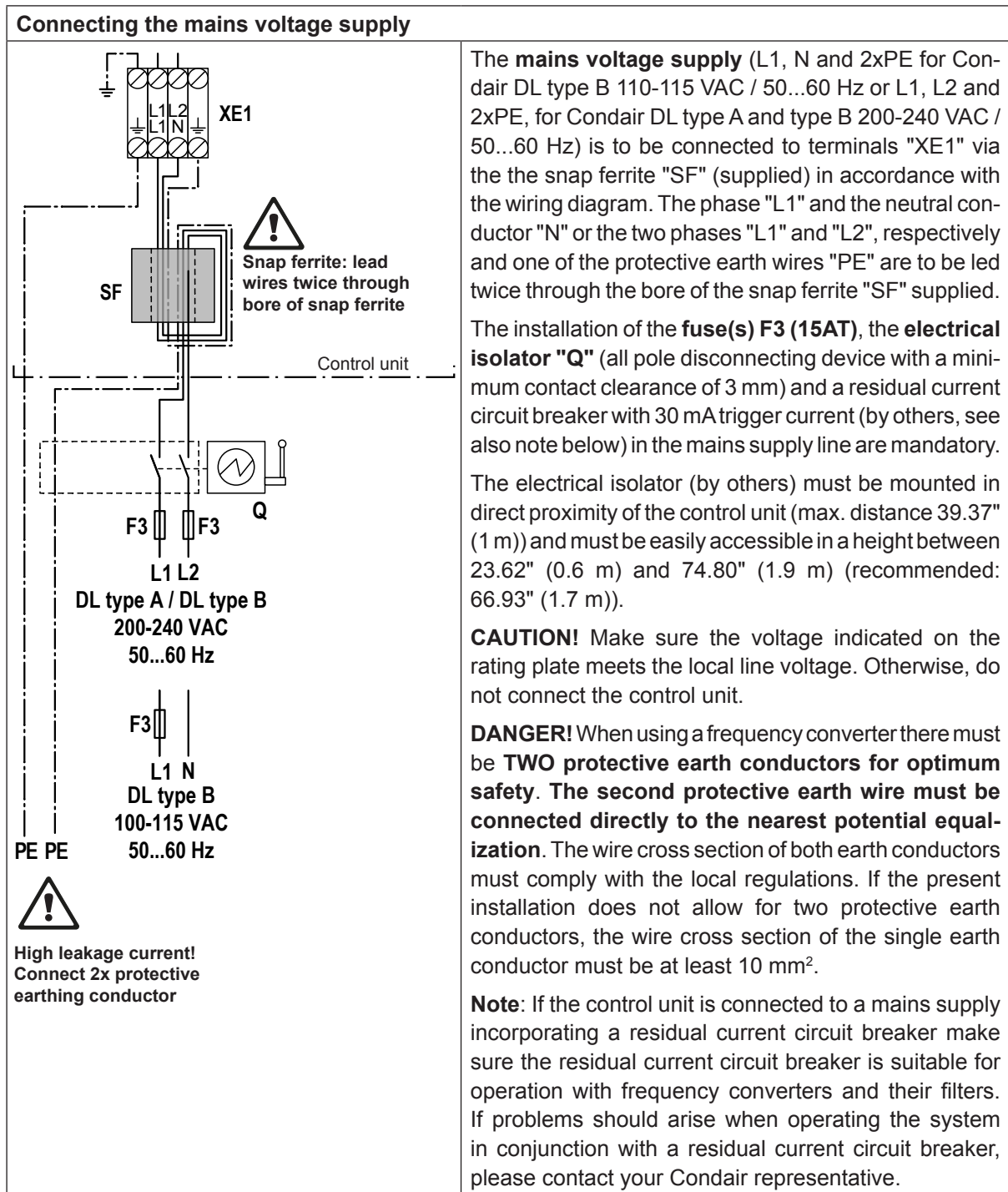

4.10.3 Connecting options

For the electrical connection of options (e.g. leak monitoring) please refer to the separate manual of the corresponding option.

5 Appendix

5.1 Dimensional drawing control unit

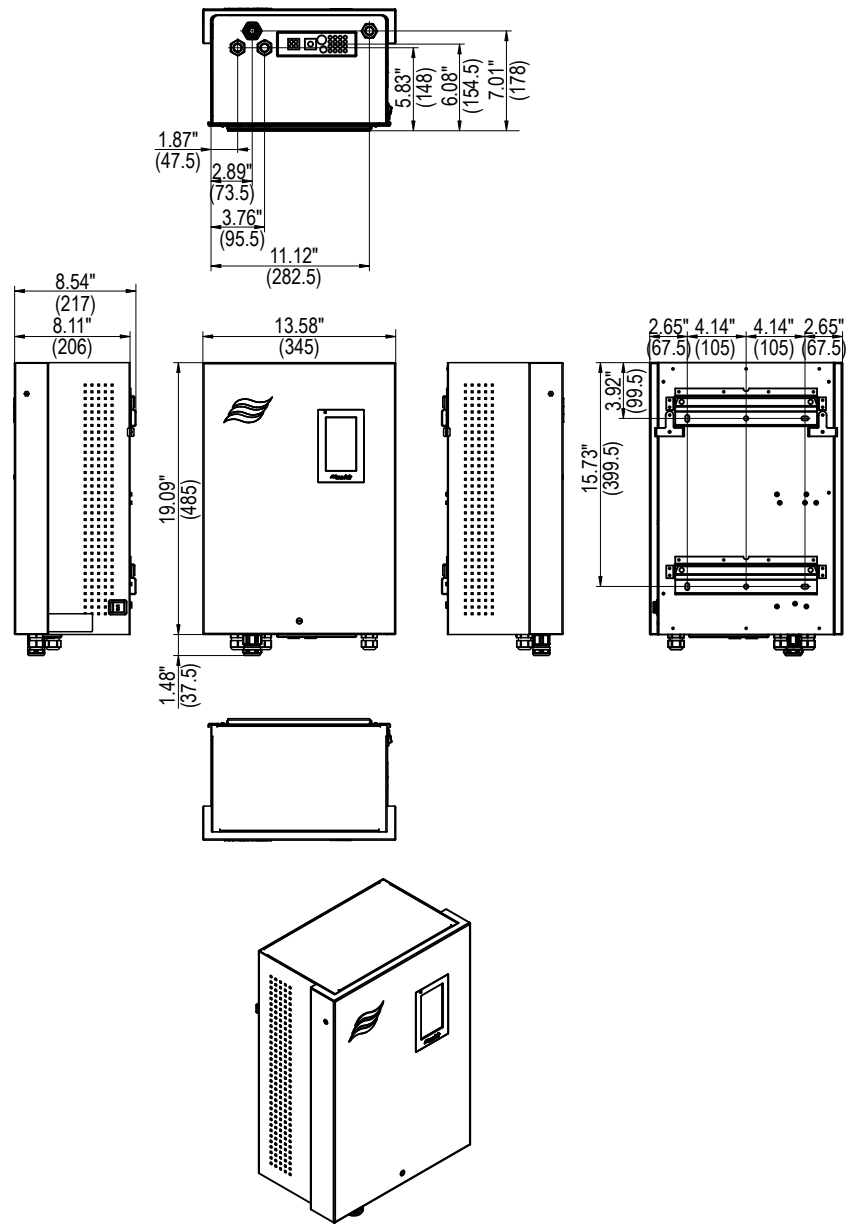

Fig. 43: Dimensional drawing control unit (Dimensions in mm)

5.2 Dimensional drawing central unit

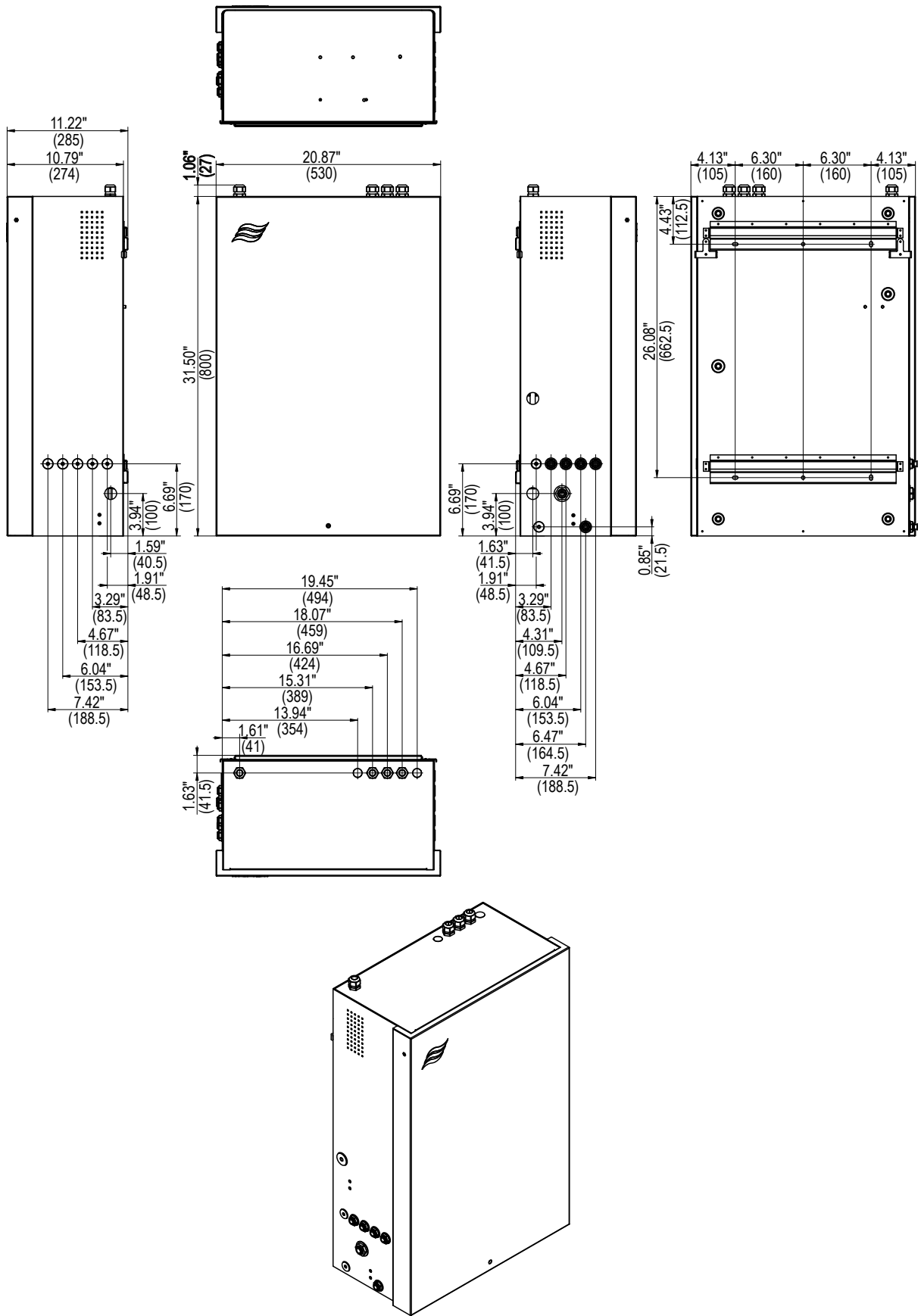

Fig. 44: Dimensional drawing central unit (Dimensions in mm)

Warranty

Condair Inc. and/or Condair Ltd. (hereinafter collectively referred to as THE COMPANY), warrant for a period of two years after installation or 30 months from manufacturer's ship date, whichever date is earlier, that THE COMPANY's manufactured and assembled products, not otherwise expressly warranted, are free from defects in material and workmanship. No warranty is made against corrosion, deterioration, or suitability of substituted materials used as a result of compliance with government regulations.

THE COMPANY's obligations and liabilities under this warranty are limited to furnishing replacement parts to the customer, F.O.B. THE COMPANY's factory, providing the defective part(s) is returned freight prepaid by the customer. Parts used for repairs are warranted for the balance of the term of the warranty on the original humidifier or 90 days, whichever is longer.

The warranties set forth herein are in lieu of all other warranties expressed or implied by law. No liability whatsoever shall be attached to THE COMPANY until said products have been paid for in full and then said liability shall be limited to the original purchase price for the product. Any further warranty must be in writing, signed by an officer of THE COMPANY.

THE COMPANY's parts or materials that are considered consumables, including but not limited to: cylinders, filters, nozzles, membranes, media, gaskets, O-rings, etc. are NOT covered by the warranty.

THE COMPANY makes no warranty and assumes no liability unless the equipment is installed in strict accordance with a copy of the catalog and installation manual in effect at the date of purchase and by a contractor approved by THE COMPANY to install such equipment.

THE COMPANY makes no warranty and assumes no liability whatsoever for consequential damage or damage resulting directly from misapplication, incorrect sizing or lack of proper maintenance of the equipment.

THE COMPANY makes no warranty and assumes no liability whatsoever for damage resulting from freezing of the humidifier, supply lines, drain lines, or quality of the water used.

THE COMPANY retains the right to change the design, specification and performance criteria of its products without notice or obligation.

THE COMPANY's limited warranty on accessories, not of the companies manufacture, such as controls, humidistats, pumps, etc. is limited to the warranty of the original equipment manufacturer from date of original shipment of humidifier.



U.S.A.
835 Commerce Park Drive
Ogdensburg, New York 13669

CANADA
2740 Fenton Road
Ottawa, Ontario K1T 3T7

TEL: 1.866.667.8321
FAX: 613.822.7964

EMAIL: na.info@condair.com
WEBSITE: www.condair.com

