

**IMPORTANT!** Read and save these instructions. This manual to be left with the equipment.



EL  
SERIES



RS  
SERIES

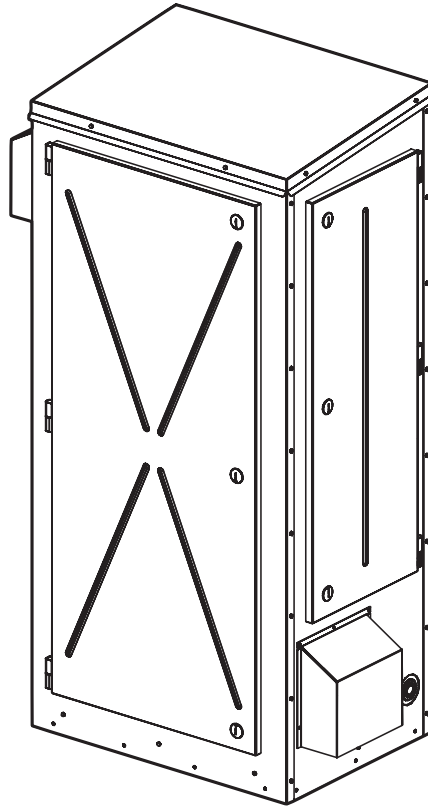

# INSTALLATION, OPERATION AND MAINTENANCE MANUAL

Outdoor Steam Humidifier  
Nortec **EL / RS**

# Thank you for choosing Nortec

Installation date (DD/MM/YYYY):

Commissioning date (DD/MM/YYYY):

Site:

Model:

Serial number:

## **Manufacturer**

Nortec Humidity Ltd.  
2740 Fenton Road, Ottawa, ON, Canada K1T 3T7  
Tel. 1.866.NORTEC1, Fax 613.822.7964  
nortec@humidity.com, www.humidity.com

## **Proprietary Notice**

This document and the information disclosed herein are proprietary data of Nortec Humidity Ltd. Neither this document, nor the information contained herein shall be reproduced, used, or disclosed to others without the written authorization of Nortec Humidity Ltd., except to the extent required for installation, operation or maintenance of the customer's equipment.

## **Liability Notice**

Nortec Humidity Ltd. does not accept any liability due to incorrect installation, maintenance or operation of the equipment, or due to the use of parts/components/equipment that are not authorized by Nortec Humidity Ltd.

## **Copyright Notice**

Copyright 2016, Nortec Humidity Ltd, All rights reserved.

Unistrut® is a trademark of Unistrut Corporation.

Technical modification rights reserved.

# Contents

---

<b>1</b>	<b>Introduction</b>	<b>1</b>
1.1	Before You Start!	1
1.2	General	1
<b>2</b>	<b>For Your Safety</b>	<b>3</b>
<b>3</b>	<b>Receiving and Storage</b>	<b>5</b>
3.1	Inspection	5
3.2	Storage and Transportation	5
<b>4</b>	<b>Product Overview</b>	<b>7</b>
4.1	General Description	7
4.2	Model Designation	9
4.3	Models Overview	10
4.4	Options	11
4.5	Accessories	11
<b>5</b>	<b>Installation</b>	<b>13</b>
5.1	General	13
5.2	Installation Overview	14
5.2.1	Air Handling Unit	14
5.2.2	Rooftop Curb	16
5.2.3	Exterior Wall	18
5.3	Site Requirements	20
5.4	Mounting the Humidifier	22
5.4.1	Location and Suggested Clearances	22
5.4.2	Pipe Chase Location	23
5.4.3	Air Handling Unit Mounting	24
5.4.4	Rooftop Curb Mounting	26
5.4.5	Exterior Wall Mounting	28
5.4.6	Mounting Checklist	30
5.5	Steam Line Connections	30
5.5.1	Steam Line	30
5.5.2	Steam Connections Checklist	31
5.6	Water Connections	32
5.6.1	Water and Drain Lines	32
5.6.2	External Freeze Protection System	35
5.6.2.1	Normally-Open and Normally-Closed Valves	35
5.6.2.2	3-Way Normally-Closed Valve	36
5.6.3	Water Connections Checklist	37
5.7	Electrical Connections	38
5.7.1	Outdoor Enclosure Wiring Diagram	40
5.7.2	Electrical Connections Checklist	40
<b>6</b>	<b>Commissioning</b>	<b>41</b>
6.1	General	41
6.2	Commissioning	41

<b>7</b>	<b>Operation and Maintenance</b>	<b>43</b>
7.1	Operating the Unit	43
7.2	Inspections During Operation	43
7.3	Maintenance	44
7.3.1	General	44
7.3.2	Heater and Fan	44
7.3.3	Freeze Protection System	44
7.3.4	Steam Cylinder	45
7.3.5	Cleaning	45
7.3.6	Scale Management (RS-OC Units only)	45
7.3.7	Restarting After a Freeze-up	46
<b>8</b>	<b>Spare Parts List</b>	<b>47</b>
<b>9</b>	<b>Decommissioning</b>	<b>55</b>
9.1	General	55
9.2	Removal from Service for Disposal or Long-term Storage	55
9.3	Disposal/Recycling	56
<b>10</b>	<b>Product Specifications</b>	<b>57</b>
10.1	Performance Data	57
10.2	Operating Data	57
10.3	Weights	57
10.4	Dimensions	58
<b>A</b>	<b>Appendix</b>	<b>i</b>
A.1	Weather Data	i
<b>B</b>	<b>Appendix</b>	<b>v</b>
B.1	Installation Checklist	v

# 1 Introduction

---

## 1.1 Before You Start!

Thank you for purchasing the Nortec EL/RS Outdoor humidifier.

The Nortec EL/RS Outdoor humidifier incorporates the latest technical advances and meets recognized safety standards. Never-the-less, improper use of the Nortec EL/RS Outdoor humidifier may result in danger to the user or third parties, and/or damage to property.

To ensure safe, proper and economical operation of the Nortec EL/RS Outdoor humidifier, please observe and comply with all information and safety instructions contained in this manual, as well as all relevant documentation of components of the installed humidification system.

If you have additional questions, please contact your Nortec representative. They will be glad to assist you.

## 1.2 General

### Limitations

The subject of this manual is the Nortec EL/RS Outdoor humidifier. It is intended as a supplement to the Nortec EL/Nortec RS installation, operation and maintenance manuals. The various options and accessories for the Nortec EL/RS Outdoor humidifier may only be described in-so-far as is necessary for proper installation and operation of the equipment. Additional information on available options and accessories can be obtained in the instructions that are supplied with them.

This manual is intended for well trained personnel who are suitably qualified for their respective tasks.

### About this Manual

This manual contains supplementary information that applies specifically to the Nortec EL/RS Outdoor humidifier. The Nortec EL/Nortec RS manuals included with the Nortec EL/RS Outdoor humidifier shipment contain information on installation, operation and maintenance which apply to both the indoor and outdoor models.

For information on the installation of controls, interior piping, interior wiring and steam lines refer to the respective Nortec EL/Nortec RS installation manual.

The operation of the Nortec EL/RS Outdoor humidifier is identical to the indoor units. Refer to the respective Nortec EL/Nortec RS operation and maintenance manual for details.

The maintenance items described in this manual are specific to the outdoor model. This is **in addition** to the regular maintenance that is described in the Nortec EL/Nortec RS operation and maintenance manual.

All illustrations in this manual are for representation purposes only. Actual appearance may vary.

### Safety Warnings Usage



#### CAUTION!

The word "CAUTION" in conjunction with the general caution symbol is used to provide safety instructions that, if neglected, may cause damage and/or malfunction of the unit or damage to property.

---



## **WARNING!**

The word "WARNING" in conjunction with the general warning symbol is used to provide safety instructions that, if neglected, may cause injury to personnel. Other specific warning symbols may also be used in place of the general symbol.

---



## **DANGER!**

The word "DANGER" in conjunction with the general danger symbol is used to provide safety instructions that, if neglected, may cause severe injury to personnel or even death. Other specific danger symbols may also be used in place of the general symbol.

---

### **Other Related Publications**

Refer to ["About this Manual" on page 1](#).

### **Storage of Manual**

Keep this manual in a place where it is safe and readily accessible. If the equipment is moved to another location, please make sure that it remains with the equipment.

If the manual is lost or misplaced, please contact your Nortec representative for a replacement.

## 2 For Your Safety

---

### General

Every person who is tasked with the installation, operation and maintenance of the Nortec EL/RS Outdoor humidifier must read and understand this manual, as well as the respective Nortec EL/Nortec RS installation, operation and maintenance manuals before performing any work. Knowing and understanding the contents of these manuals is a basic requirement for protecting personnel against any kind of danger, preventing faulty operation, and operating the unit safely and correctly.

All labels, signs and marking applied to the Nortec EL/RS Outdoor humidifier must be observed and kept in a readable state.

### Personnel Qualifications

All procedures described in this manual must only be performed by personnel who are adequately qualified, well trained and are authorized by the customer.

For safety and warranty reasons, any activity beyond the scope of this manual must only be performed by qualified personnel authorized by Nortec.

All personnel working with the Nortec EL/RS Outdoor humidifier must be familiar with, and comply with the appropriate regulations on workplace safety and prevention of accidents.

### Intended Use

The Nortec EL/RS Outdoor humidifier is intended exclusively for air humidification using a Nortec-approved steam distributor within specified operating conditions (refer to "[Operating Data](#)" on page 57 and "[Site Requirements](#)" on page 20 for details). Any other type of application, without the express written consent of Nortec, is considered to be NOT conforming to its intended purpose, and may lead to dangerous operation and will void the warranty.

In order to operate the equipment in the intended manner all information contained in this manual, in particular the safety instructions, must be observed closely.

### Safety Precautions that Must be Observed



**DANGER!**  
Risk of electric shock!

**The Nortec EL/RS Outdoor humidifier is mains powered. Live parts may be exposed when the door panels are opened. Touching live parts may cause severe injury or even death.**

#### Prevention:

The Nortec EL/RS Outdoor humidifier must be connected to the mains only after all installation work has been completed, checked for correct workmanship, and the door panels are closed and fastened securely.

Only qualified personnel should perform maintenance or repairs on the unit.

DO NOT service the unit while standing on wet or icy surfaces, or in wet weather.

Follow lockout procedures whenever servicing the unit.

---

**WARNING!****Risk of severe burns from contact with hot steam vapors!**

The Nortec EL/RS Outdoor humidifier produces hot steam vapors for humidification. Bare skin in contact with hot steam vapors can result in severe burns.

**Prevention:** Never perform any work on the steam system (including the steam lines, steam distributors, etc.) while the humidifier is operating. Shut down the humidifier and wait for the components to cool down before working on the steam system.

**WARNING!****Risk of severe burns from contact with hot surfaces!**

The components in the humidifier plumbing cabinet get very hot during operation. Bare skin in contact with hot surfaces can result in severe burns.

**Prevention:** Avoid contact with hot surfaces. Shut down the humidifier and wait for the components to cool down before working on the unit.

**CAUTION!****Electrostatic discharge (ESD)!**

The components in the control cabinet are sensitive to electrostatic discharge (ESD).

**Prevention:** Take appropriate measures to protect the electronic components inside the unit against damage caused by electrostatic discharge (ESD). Refer to ANSI/ESD-S20.20.

**Preventing Unsafe Operation**

All personnel working with the Nortec EL/RS Outdoor humidifier must immediately report to the customer any alterations to the unit that may affect safety, and **secure the humidifier against accidental power-up.**

**Modifications to the Unit Prohibited**

**Modifications are NOT permitted** on the Nortec EL/RS Outdoor humidifier without the express written consent of Nortec.

# 3 Receiving and Storage

## 3.1 Inspection

After receiving the shipment, inspect the goods as follows:

- Inspect the shipping boxes for damage.  
Report any shipping box damages to the shipping company without delay.
- Check the goods against the packing slip to ensure that all items have been delivered.
- Report any shortages to your Nortec representative within 48 hours of receipt of the goods. Nortec does not assume responsibilities for any shortages beyond this period.
- Unpack the parts/components and check for any damage.  
If parts/components are damaged, notify the shipping company immediately.
- Verify the model type, capacity and voltage on the specification label to ensure that it is suitable for your installation site. Refer to [Figure 3 on page 9](#).

## 3.2 Storage and Transportation

### Moving and Handling the Unit

The Nortec EL/RS Outdoor humidifier is bolted to a shipping skid and enclosed in a packaging crate before it is shipped from the factory. While still attached to the skid, the humidifier can be lifted onto a rooftop or other mounting location using a forklift or crane. Refer to [Table 9 on page 57](#) for weights.



**CAUTION!**  
**Risk of damage to equipment.**

**Prevention:** DO NOT drop the humidifier when handling the unit. Protect the unit from damage by tethers and other lifting equipment.

### Storage

Store the Nortec EL/RS Outdoor humidifier in its original packaging inside a protected area that meets the following requirements until it is installed, or if it needs to be stored for an extended period of time:

- Room temperature: 41 to 104°F (5 to 40°C)
- Room humidity: 10 to 75% RH

### Transportation

For optimum protection always transport the unit and components in their original packaging, and use appropriate lifting/transporting devices.

### Packaging

Keep the original packaging of the unit/components for later use.

If the packaging needs to be disposed off, observe local regulations on waste disposal. Recycle packaging where possible.

This page intentionally left blank

## 4 Product Overview

### 4.1 General Description

The Nortec EL/RS Outdoor humidifier is UL-approved for installation outdoors. It is housed in an enclosure that has an IP54 rating, and comes with built-in heating, ventilation and freeze protection for the plumbing components. The unit is intended to operate in -40 °F to 104 °F (-40 °C to +40 °C) temperatures.

The Nortec EL/RS Outdoor humidifier comes in three different housing sizes depending on the steam capacity. Refer to [Figure 1](#). These units can range from 5 lb/h (2.2 kg/h) to 200 lb/h (91 kg/h) – refer to "[Models Overview](#)" on page 10.

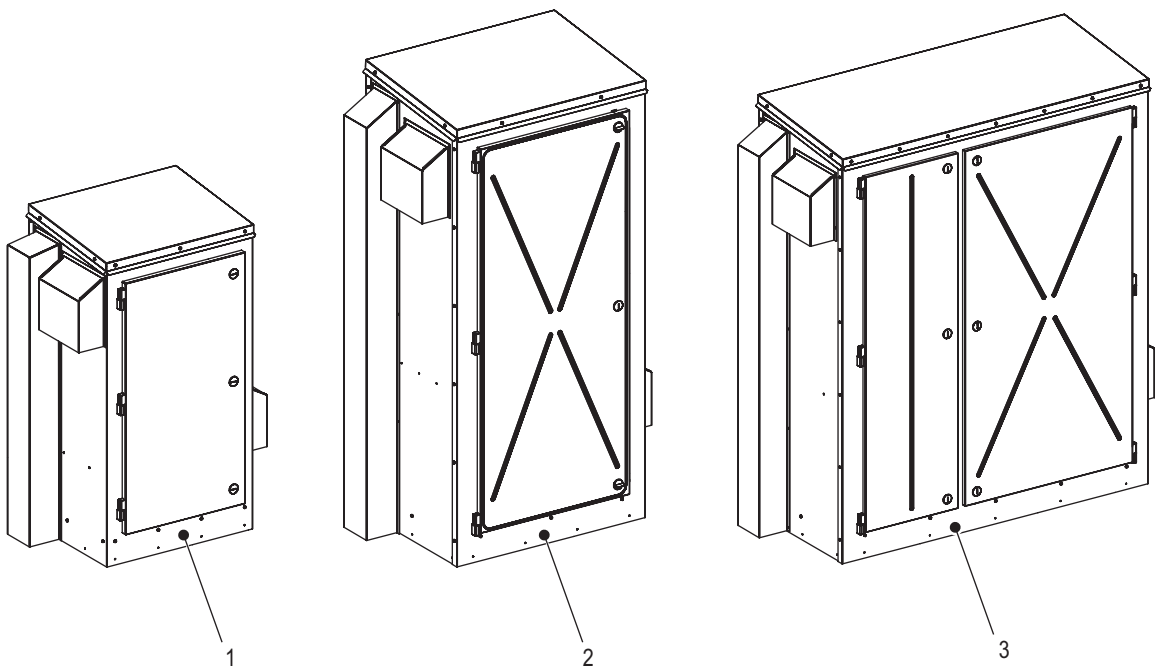

*Figure 1: Nortec EL/RS Outdoor Steam Humidifier Model Sizes*

- 1 Small housing, Nortec EL-OC
- 2 Medium housing, Nortec EL/RS-OC
- 3 Large housing, Nortec EL/RS-OC

[Figure 2 on page 8](#) shows the major components of the Nortec EL/RS Outdoor humidifier. The built-in heating system consists of a heater that is activated during the winter months, and controlled by an internal thermostat to maintain an appropriate operating temperature inside the enclosure. The heat control is automatic, and cannot be activated manually.

In addition, a mechanical freeze protection valve drains all the water from the steam cylinder(s), fill cup, valves and hoses to prevent freeze up when the temperature inside the enclosure drops down to 43 °F (6 °C).

During warm weather, a weather-shielded exhaust fan moves air through the enclosure to maintain an appropriate operating temperature. The exhaust fan is automatically controlled by a thermostat, and cannot be activated manually.

The Nortec EL/RS Outdoor humidifier is also equipped with a remote fault indication board (standard, not shown) that can be used to remotely monitor the unit.

All other features of the Nortec EL/RS Outdoor humidifier are similar to the Nortec EL/RS humidifier. Refer to the respective Nortec EL/RS humidifier manuals for details.

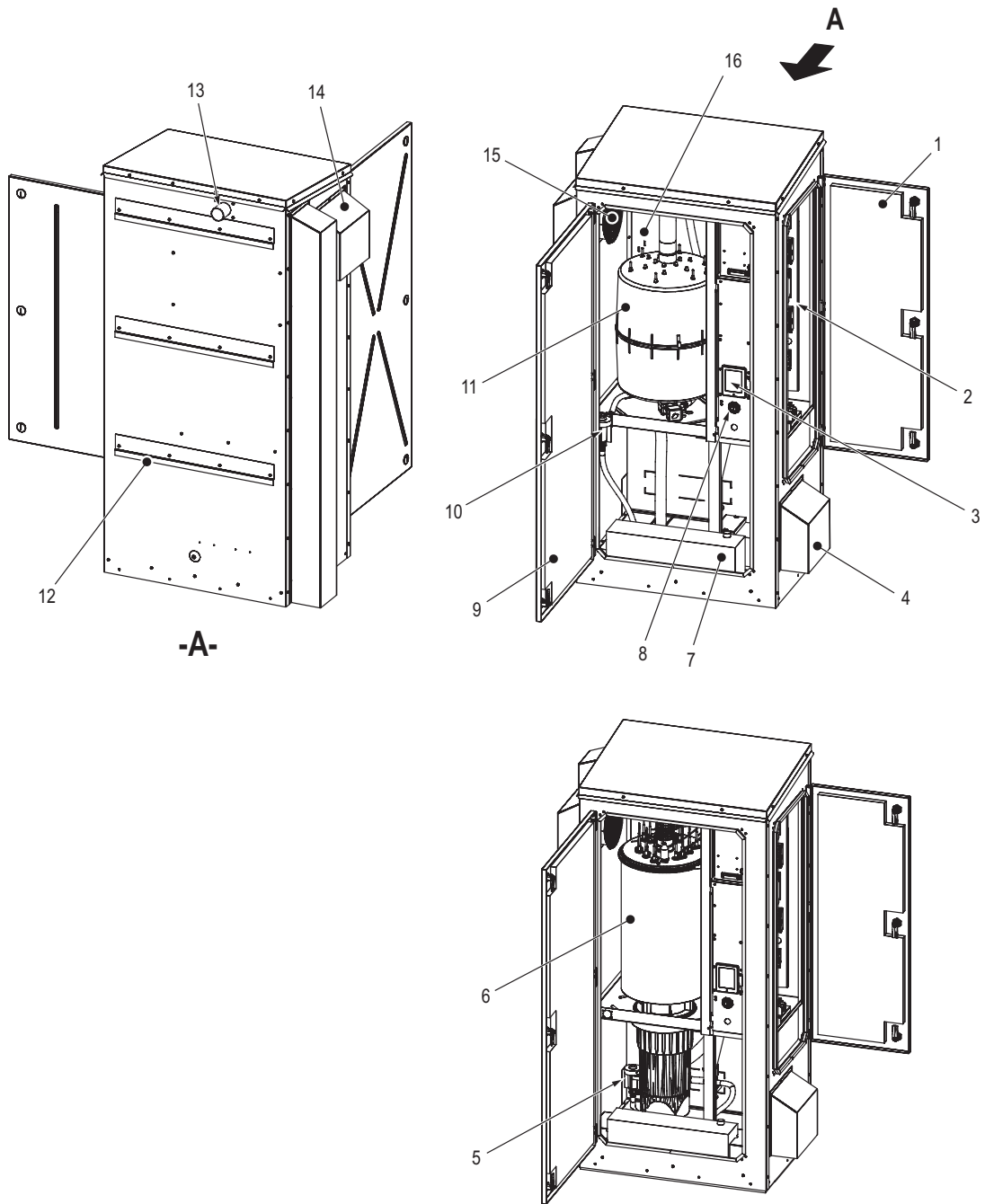

Figure 2: Nortec EL/RS Outdoor Humidifier (medium size unit shown)

- |   |  |    |   |
|---|--|----|---|
| 1 | Side door  | 9  | Front door  |
| 2 | Controls cabinet   | 10 | Mechanical freeze protection valve (EL-OC and RS-OC without scale tank) |
| 3 | Touchscreen display  | 11 | Steam cylinder (EL-OC)  |
| 4 | Intake shroud (and filter)                                 | 12 | Mounting bracket  |
| 5 | Mechanical freeze protection valve (RS-OC with scale tank) | 13 | Steam outlet  |
| 6 | Cylinder, steam (RS-OC)                                    | 14 | Exhaust shroud  |
| 7 | Heater   | 15 | Exhaust fan (and filter)  |
| 8 | Switch, On/Off   | 16 | Plumbing cabinet  |

## 4.2 Model Designation

The specification label on the side of the Nortec EL/RS Outdoor humidifier shows its model number, serial number and ratings – refer to [Figure 3](#). The breakdown of the model number is shown in [Figure 4](#).

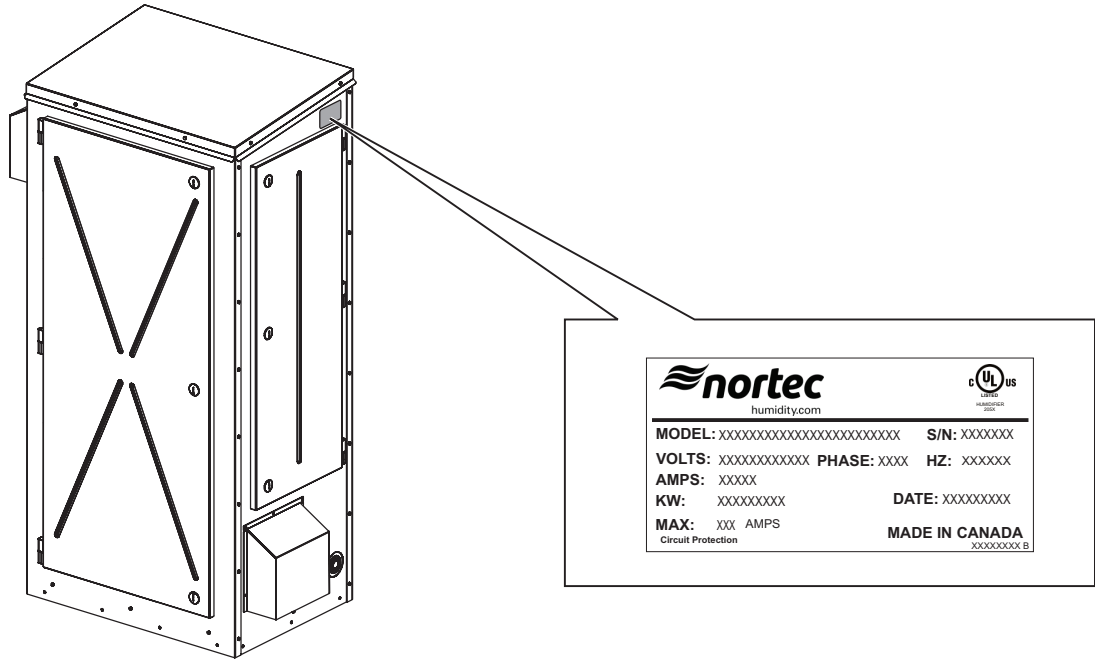

Figure 3: Nortec EL/RS Outdoor Steam Humidifier Specification Label

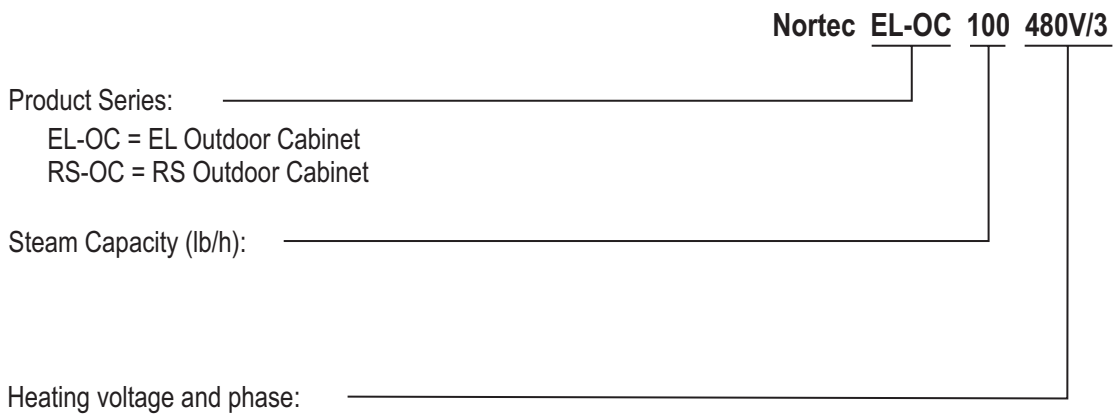

Figure 4: Model Breakdown

## 4.3 Models Overview

The Nortec EL/RS Outdoor humidifier is available in different sizes with different heating voltages and steam capacities as shown in [Table 1](#) below.

*Table 1: Nortec EL/RS Outdoor Steam Humidifier Models*

Housing Size	Nortec Model	110-120V/1~	208V/1~	220-240V/1~	277V/1~	380-415V/1~	440-480V/1~	550-600V/1~	208V/3~	220-240V/3~	380V/3~	440-480V/3~	550-600V/3~
		lb/h (kg/h)	lb/h (kg/h)	lb/h (kg/h)	lb/h (kg/h)	lb/h (kg/h)	lb/h (kg/h)	lb/h (kg/h)	lb/h (kg/h)	lb/h (kg/h)	lb/h (kg/h)	lb/h (kg/h)	lb/h (kg/h)
<b>S</b>	EL-OC 005	5 (2.2)	–	–	–	–	–	–	–	–	–	–	–
	EL-OC 010	–	10 (4.5)	10 (4.5)	10 (4.5)	10 (4.5)	10 (4.5)	10 (4.5)	–	–	–	–	–
	EL-OC 020	–	20 (9)	20 (9)	20 (9)	20 (9)	20 (9)	20 (9)	20 (9)	20 (9)	20 (9)	20 (9)	20 (9)
	EL-OC 030	–	–	–	–	–	–	–	30 (13.6)	30 (13.6)	30 (13.6)	30 (13.6)	30 (13.6)
<b>M</b>	EL-OC 050	–	–	–	–	–	–	–	50 (22.7)	50 (22.7)	50 (22.7)	50 (22.7)	50 (22.7)
	EL-OC 075	–	–	–	–	–	–	–	75 (34)	75 (34)	75 (34)	75 (34)	75 (34)
	EL-OC 100	–	–	–	–	–	–	–	90 (41)	100 (45)	100 (45)	100 (45)	100 (45)
<b>M</b>	RS-OC 010	–	10.9 (4.9)	10.9 (4.9)	–	–	9.7 (4.4)	11.4 (5.2)	10.9 (4.9)	10.9 (4.9)	–	11.3 (5.1)	11.1 (5.0)
	RS-OC 015	–	15.9 (7.2)	14.5 (6.6)	–	–	14.1 (6.4)	14.7 (6.7)	15.9 (7.2)	14.5 (6.6)	–	14.6 (6.6)	17.6 (8.0)
	RS-OC 020	–	21.2 (9.6)	21.2 (9.6)	–	–	18.8 (8.5)	19.6 (8.9)	21.2 (9.6)	21.2 (9.6)	–	19.4 (8.8)	22.8 (10.3)
	RS-OC 030	–	31.8 (14.4)	31.8 (14.4)	–	–	31.5 (14.3)	31.4 (14.2)	28.8 (13.1)	31.8 (14.4)	–	31.5 (14.3)	31.4 (14.2)
	RS-OC 045	–	–	–	–	–	–	–	47.7 (21.6)	47.9 (21.7)	–	45.2 (20.5)	47.1 (21.4)
	RS-OC 065	–	–	–	–	–	–	–	71.6 (32.5)	71.9 (32.6)	–	63.0 (28.6)	70.6 (32.0)
	RS-OC 090	–	–	–	–	–	–	–	–	–	–	94.6 (42.9)	94.3 (42.8)
<b>L</b>	EL-OC 150*	–	–	–	–	–	–	–	150 (68)	150 (68)	150 (68)	150 (68)	150 (68)
	EL-OC 200*	–	–	–	–	–	–	–	180 (82)	200 (91)	200 (91)	200 (91)	200 (91)
<b>L</b>	RS-OC 090*	–	–	–	–	–	–	–	95.4 (43.3)	94.6 (42.9)	–	–	–
	RS-OC 130*	–	–	–	–	–	–	–	143.2 (65.0)	141.8 (64.3)	–	126.0 (57.2)	141.2 (64.1)
	RS-OC 180*	–	–	–	–	–	–	–	–	–	–	189.2 (85.8)	188.6 (85.5)

\* These models have two steam cylinders.

## 4.4 Options

Table 2 shows the list of options for the Nortec EL/RS Outdoor humidifier. Contact your local Nortec representative for details.

Table 2: Nortec EL/RS Outdoor Humidifier Options

Option	Application
Mounting bracket	Provides a means to attach the unit to an air handling unit or an exterior wall.
Scale tank (RS-OC only)	Provides a separate reservoir underneath the steam cylinder for scale collection. The addition of this option reduces maintenance time significantly. Minerals removed from the water during steam production will collect in the scale reservoir rather than in the tank. For the unit with two steam cylinders (RS-OC 90, 130 and 180), order two for each humidifier.
Accessory relay PCB (printed circuit board)	Printed circuit board with relay contacts for connecting other accessories such as fans and supply water flushing valves.
Internal primary fusing (EL-OC only)	Optional internal fuse for heating voltage power supply in the EL-OC models (only). Only available as a factory-installed option. <b>Note:</b> This is not a substitute for a dedicated external disconnect switch.
BACnet MSTP BTL	PCB to provide BTL-certified BACnet MS/TP. This option also enables full Master functionality when using BACnet MS/TP.
BACnet IP BTL	PCB to provide BTL-certified BACnet IP.
LonWorks board	Supplementary board to connect the humidifier to a building management system using LonWorks.

## 4.5 Accessories

Table 3 shows the list of accessories for the Nortec EL/RS Outdoor humidifier. Contact your local Nortec representative for details. To install and operate the accessories, please refer to the instructions supplied with the accessories.

Table 3: Nortec EL/RS Outdoor Humidifier Accessories

Accessory	Application
Steam distributor	Steam distribution system for use in an air duct.
SAME steam distribution manifold	Steam distribution system for use in an air duct where reduced absorption distance is required.
Digital or analog control humidistat with either On/Off or modulating operation	Input device used to meter the output of the humidifier based on the sensed relative humidity. The humidistat can be installed in the conditioned space that is being humidified, or within the duct.
Digital RH transducer	Input device used to communicate the relative humidity in a conditioned space or a duct to the humidifier.
Digital or analog high limit humidistat with either On/Off or modulating operation	Input device used to limit the output of the humidifier by either shutting it down or throttling it down when the humidity in the duct approaches the high limit.
Air proving switch	Input device to ensure that humidification only occurs when air is moving through the duct.
Outdoor temperature sensor	Input device used to communicate the outdoor temperature to the humidistat so that it can lower the setpoint value during cold weather to prevent condensation on exterior windows/surfaces.

This page intentionally left blank

# 5 Installation

---

## 5.1 General

Strictly observe and perform all installation tasks including the mounting of the unit and connection of the water, steam and power supplies as described in this manual.

Comply with all local and national codes dealing with water, steam and electrical installations.

Nortec does not accept any liability for installation of humidification equipment by unqualified personnel, or the use of equipment/parts that are not authorized by Nortec.

### **Personnel Qualifications**

All installation work must be performed only by licensed personnel authorized by the customer. It is the customer's responsibility to verify qualifications of the personnel.

### **Safety**

Observe all safety precautions noted in ["For Your Safety" on page 3](#).

## 5.2 Installation Overview

The Nortec EL/RS Outdoor humidifier can be installed in three different ways – mounted directly on a suitably reinforced vertical surface on the air handling unit (AHU), rooftop on a curb, or a suitable vertical surface on an exterior wall. [Figure 5](#), [Figure 6 on page 16](#) and [Figure 7 on page 18](#) show overviews of the different mounting arrangements.

### 5.2.1 Air Handling Unit

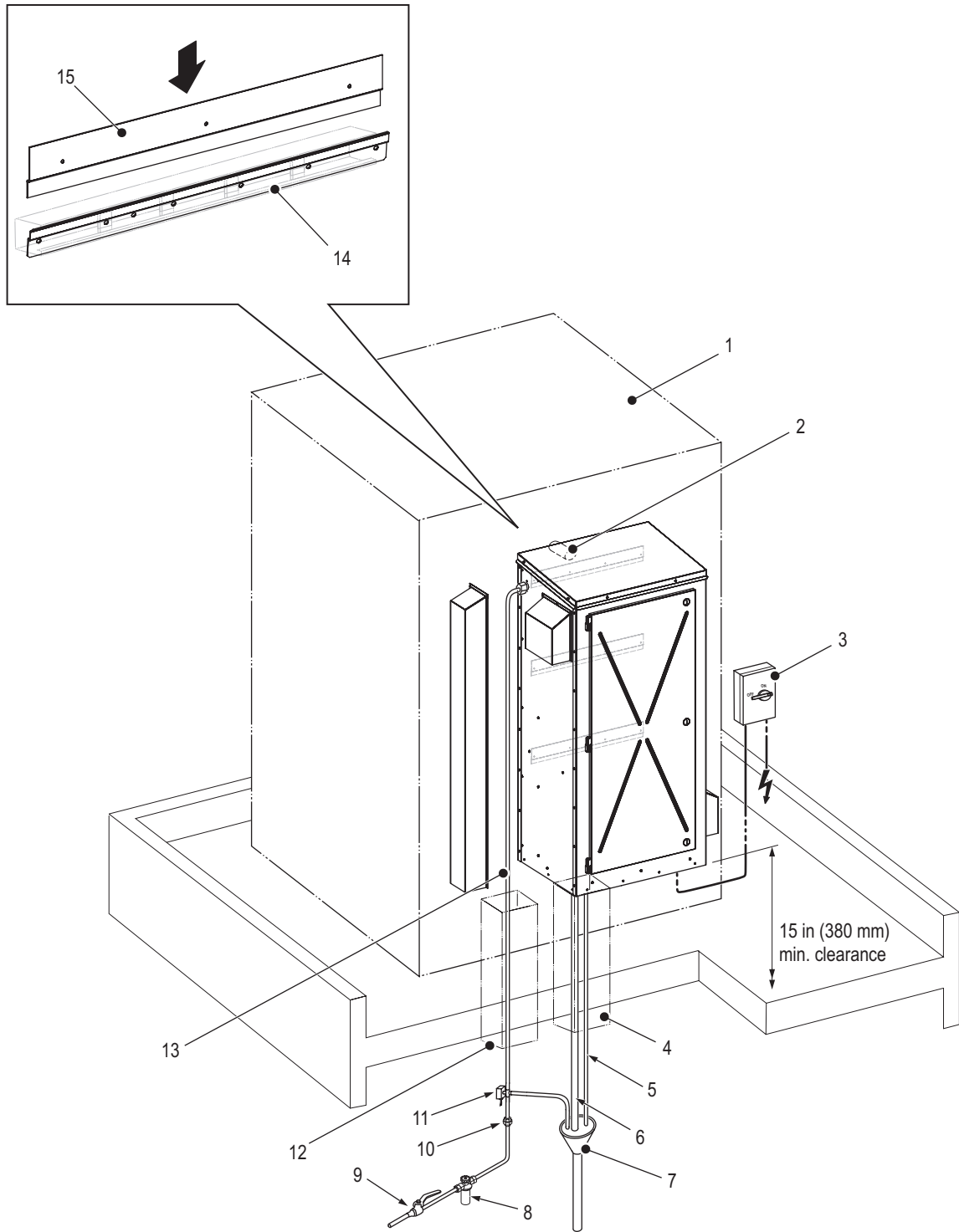

Figure 5: Typical Installation on Air Handling Unit (medium size unit shown)

Legend:

- 1 Air handling unit
- 2 Steam outlet, connection into air handling unit
- 3 External fused disconnect switch (supplied by others)
- 4 Pipe chase (drain lines). See Note 1 below.
- 5 Drain line (freeze protection valve), 3/8 in (9.5 mm) I.D. See Note 2 below.
- 6 Drain line (main) – 1-3/16 in (30 mm) I.D. See Note 2 below.
- 7 Air gap funnel. See Note 3 below.
- 8 Filter, 5 µm (optional, but recommended)
- 9 Shutoff valve (supplied by others)
- 10 Union fitting (supplied by others)
- 11 3-way normally-closed valve, or normally-open and normally-closed valves (supplied by others). See Note 4 below.
- 12 Pipe chase (water supply line)
- 13 Water supply line, minimum 1/2 in (13 mm). See Note 5 below.
- 14 Mounting bar (supplied – ×2 for small unit, ×3 for medium/large unit) secured to air handling unit. See Note 6 below.
- 15 Mounting bracket (×2 for small unit, ×3 for medium/large unit) secured to back of humidifier

**Note 1:** Route all drain lines through a pipe chase. Seal the pipe chase to prevent rising steam from entering the bottom of the humidifier enclosure, and to isolate the unit from the pressure inside the building.

**Note 2:** In cold climates all drain lines must be properly trace heated and insulated to prevent freezing.

**Note 3:** The air gap funnel should be located inside the building, as shown, and connected to a dedicated building drain (recommended) with a drainage capacity of at least 2.3 gpm (8.7 L/min) for an EL-OC unit and 6.7 gpm (30 L/min) for a RS-OC unit – per steam cylinder. The drain line exiting the funnel should be minimum 7/8 in (22 mm) in diameter for an EL-OC unit, and minimum 1-3/4 in (45 mm) for a RS-OC unit. The drain lines into the funnel must not touch the sides or bottom of the funnel. In large units, separate air gap funnels must be used for drain lines from each cylinder.

**Note 4:** In cold climates the water supply line should be protected with a freeze protection system utilizing either a normally-open and a normally-closed valve, or a 3-way normally-closed valve. Refer to ["External Freeze Protection System" on page 35](#) for details.

**Note 5:** The water supply line should have a 1/2 in NPT female end for connection to the unit. It must be routed through a pipe chase. In cold climates it must be properly trace heated and insulated to prevent freezing.

**Note 6:** The supplied mounting bars must be installed on a reasonably flat vertical mounting surface on the air handling unit, that is stable and suitably reinforced (strength equivalent to 2×4 stud or 1-5/8 in × 1-5/8 in ×12 gauge Unistrut® channel). Make sure that the mounting surface is capable of supporting the entire weight of the unit when it is in operation. Refer to [Table 9 on page 57](#) for weight of the unit.

This mounting arrangement is advantageous because the steam piping is shorter, thus minimizing condensate losses and backpressure in the line. Do not install the Nortec EL/RS Outdoor humidifier in an outdoor environment where the unit is exposed to severe weather or where the temperature drops below -40 °F (-40 °C).

---

**IMPORTANT!** In units operating in cold climates, the area around the unit must be kept clear of snow and ice accumulation to permit opening and closing of the front and side doors.

---

Refer to ["Site Requirements" on page 20](#), and ["Air Handling Unit Mounting" on page 24](#) for mounting details. Make sure the required clearance is maintained – refer to [Figure 8 on page 22](#). Observe all local and national installation codes. Nortec is not responsible for any installation code violations.

The water supply and all drain lines must be properly trace heated and insulated to prevent freezing.

---

**IMPORTANT!** The warranty does not cover damage to the humidifier resulting from freezing.

---

## 5.2.2 Rooftop Curb

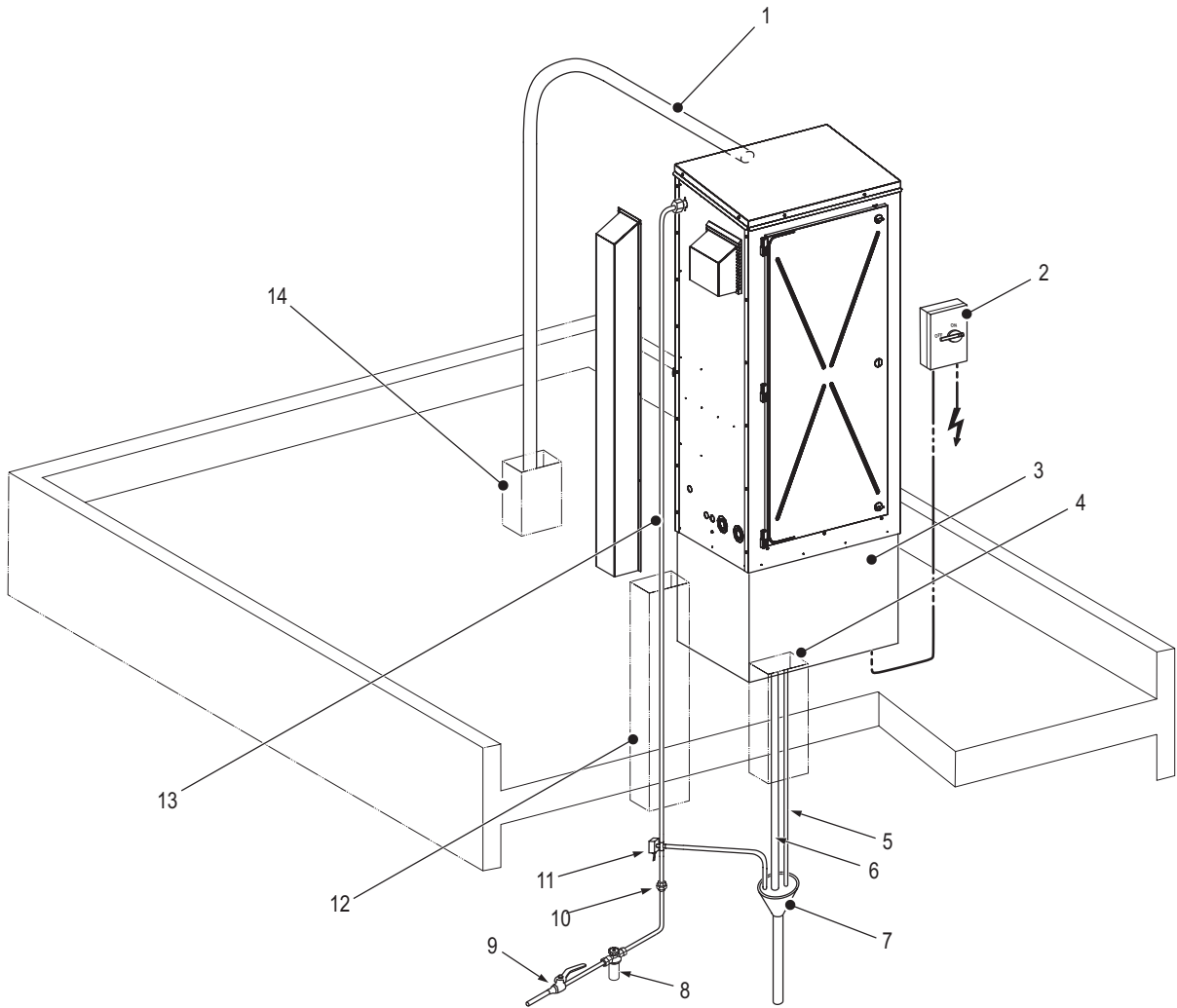

Figure 6: Typical Installation on Rooftop Curb (medium size unit shown)

- 1 Steam line, must maintain a constant minimum upslope of 10° or downslope of 2°, and must be insulated
- 2 External fused disconnect switch (supplied by others)
- 3 Curb. See Note 1 below.
- 4 Pipe chase (drain lines). See Note 2 below.
- 5 Drain line (freeze protection valve), 3/8 in (9.5 mm) I.D. See Note 3 below.
- 6 Drain line (main) – 1-3/16 in (30 mm) I.D. See Note 3 below.
- 7 Air gap funnel. See Note 4 below.
- 8 Filter, 5 µm (optional, but recommended)
- 9 Shutoff valve (supplied by others)
- 10 Union fitting (supplied by others)
- 11 3-way normally-closed valve, or normally-open and normally-closed valves (supplied by others). See Note 5 below.
- 12 Pipe chase (water supply line)
- 13 Water supply line, minimum 1/2 in (13 mm). See Note 6 below.
- 14 Pipe chase (steam line)

**Note 1:** The curb must be capable of supporting the entire weight of the unit when it is in operation – refer to [Table 9 on page 57](#). The curb must be properly anchored to the rooftop.

**Note 2:** Route all drain lines through a pipe chase. Seal the pipe chase to prevent rising steam from entering the bottom of the unit, and to isolate the unit from the pressure inside the building.

**Note 3:** In cold climates all drain lines must be properly trace heated and insulated to prevent freezing.

**Note 4:** The air gap funnel should be located inside the building, as shown, and connected to a dedicated building drain (recommended) with a drainage capacity of at least 2.3 gpm (8.7 L/min) for an EL-OC unit and 6.7 gpm (30 L/min) for a RS-OC unit – per steam cylinder. The drain line exiting the funnel should be minimum 7/8 in (22 mm) in diameter for an EL-OC unit, and minimum 1-3/4 in (45 mm) for a RS-OC unit. The drain lines into the funnel must not touch the sides or bottom of the funnel. In large units, separate air gap funnels must be used for drain lines from each cylinder.

**Note 5:** In cold climates the water supply line should be protected with a freeze protection system utilizing either a normally-open and a normally-closed valve, or a 3-way valve. Refer to ["External Freeze Protection System" on page 35](#) for details.

**Note 6:** The water supply line should have a 1/2 in NPT female end for connection to the unit. It must be routed through a pipe chase. In cold climates it must be properly trace heated and insulated to prevent freezing.

The Nortec EL/RS Outdoor humidifier is designed to be mounted on a curb. When choosing this mounting arrangement, locate the humidifier as close as possible to the steam distributor to minimize condensate losses and backpressure in the line. Do not install the Nortec EL/RS Outdoor humidifier in an outdoor environment where the unit is exposed to severe weather or where the temperature drops below -40 °F (-40 °C).

---

**IMPORTANT!** In units operating in cold climates, the area around the curb must kept clear of snow and ice accumulation to permit opening and closing of the front and side doors in the unit.

---

Refer to ["Site Requirements" on page 20](#), and ["Rooftop Curb Mounting" on page 26](#) for mounting details. Make sure the required clearance is maintained – refer to [Figure 8 on page 22](#). Observe all local and national installation codes. Nortec is not responsible for any installation code violations.

The water supply and all drain lines must be properly trace heated and insulated to prevent freezing.

---

**IMPORTANT!** The warranty does not cover damage to the humidifier resulting from freezing.

---

## 5.2.3 Exterior Wall

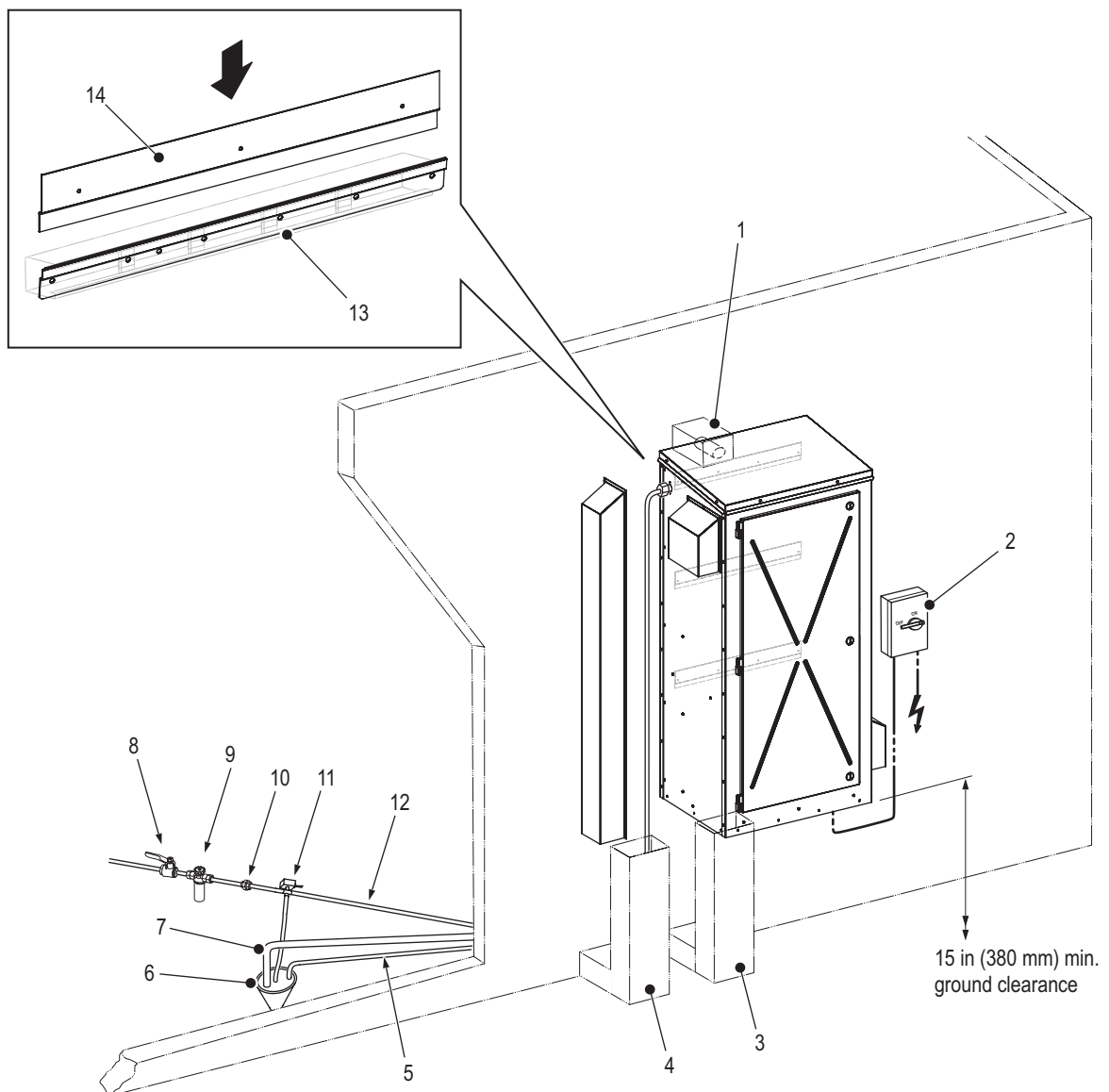

Figure 7: Typical Installation on an Exterior Wall (medium size unit shown)

- 1 Pipe chase (steam line)
- 2 External fused disconnect switch (supplied by others)
- 3 Pipe chase (drain lines). See Note 1 below.
- 4 Pipe chase (water supply line)
- 5 Drain line (freeze protection valve), 3/8 in (9.5 mm) I.D. See Note 2 below.
- 6 Air gap funnel. See Note 3 below.
- 7 Drain line (main) – 1-3/16 in (30 mm) I.D. See Note 2 below.
- 8 Shutoff valve (supplied by others)
- 9 Filter, 5 µm (optional, but recommended)
- 10 Union fitting (supplied by others)
- 11 3-way normally-closed valve, or normally-open and normally-closed valves (supplied by others). See Note 4 below.
- 12 Water supply line, minimum 1/2 in (13 mm). See Note 5 below.
- 13 Mounting bar (supplied – ×2 for small unit, ×3 for medium/large unit) secured to an exterior wall. See Note 6 below.
- 14 Mounting bracket (×2 for small, ×3 for medium/large unit) secured to back of humidifier

**Note 1:** Route all drain lines through a pipe chase. Seal the pipe chase to isolate the unit from the pressure inside the building.

**Note 2:** In cold climates all drain lines must be properly trace heated and insulated to prevent freezing.

**Note 3:** The air gap funnel should be located inside the building, as shown, and connected to a dedicated building drain (recommended) with a drainage capacity of at least 2.3 gpm (8.7 L/min) for an EL-OC unit and 6.7 gpm (30 L/min) for a RS-OC unit – per steam cylinder. The drain line exiting the funnel should be minimum 7/8 in (22 mm) in diameter for an EL-OC unit, and minimum 1-3/4 in (45 mm) for a RS-OC unit. The drain lines into the funnel must not touch the sides or bottom of the funnel. In large units, separate air gap funnels must be used for drain lines from each cylinder.

**Note 4:** In cold climates the water supply line should be protected with a freeze protection system utilizing either a normally-open and a normally-closed valve, or a 3-way valve. Refer to ["External Freeze Protection System" on page 35](#) for details.

**Note 5:** The water supply line should have a 1/2 in NPT female end for connection to the unit. It must be routed through a pipe chase. In cold climates it must be properly trace heated and insulated to prevent freezing.

**Note 6:** The supplied mounting bars must be installed on a reasonably flat vertical mounting surface on the air handling unit, that is stable and suitably reinforced (strength equivalent to 2×4 stud or 1-5/8 in × 1-5/8 in ×12 gauge Unistrut® channel). Make sure that the mounting surface is capable of supporting the entire weight of the unit when it is in operation – refer to [Table 9 on page 57](#).

When choosing this mounting arrangement, locate the humidifier as close as possible to the steam distributor to minimize condensate losses and backpressure in the line. Do not install the Nortec EL/RS Outdoor humidifier in an outdoor environment where the unit is exposed to severe weather or where the temperature drops below -40 °F (-40 °C).

---

**IMPORTANT!** In units operating in cold climates, the area around the unit must kept clear of snow and ice accumulation to permit opening and closing of the front and side doors.

---

Refer to ["Site Requirements"](#) below, and ["Exterior Wall Mounting" on page 28](#) for mounting details. Make sure the required ground clearance is maintained – refer to [Figure 8 on page 22](#). Observe all local and national installation codes. Nortec is not responsible for any installation code violations.

The water supply and all drain lines must be properly trace heated and insulated to prevent freezing.

---

**IMPORTANT!** The warranty does not cover damage to the humidifier resulting from freezing.

---

## 5.3 Site Requirements

As mentioned previously, the Nortec EL/RS Outdoor humidifier can be mounted on a suitably reinforced vertical surface on the air handling unit (AHU), a suitably sized curb on the rooftop, or a suitable vertical surface on an exterior wall. Humidifiers typically operate in the cold winter months. As a result they should be located where services to the unit are not in any danger of freezing, and where it is safe and convenient for maintenance personnel to service the unit. In addition, the length of the steam line should be kept as short as possible to minimize heat losses. In all cases consult national and local installation codes. Nortec is not responsible for installation code violations.

---

**IMPORTANT!** The warranty does not cover damage to the humidifier caused by neglect or due to freezing.

---

Refer to "[Installation Overview](#)" on page 14 for the different ways the Nortec EL/RS Outdoor humidifier can be installed.

In preparation for installation of the Nortec EL/RS Outdoor humidifier, make sure that the following site requirements are satisfied regardless of the mounting arrangement. Report any discrepancies to the site engineer.

### Mounting

- Do not install the Nortec EL/RS Outdoor humidifier in an outdoor environment where the unit is exposed to severe weather, or where the temperature drops below -40 °F (-40 °C). Refer to [Table A1 on page i](#) for weather data.
- Do not mount the unit in locations where the wind speed exceeds 100 mph (160 km/h). When wind speed exceeds this limit, external bracing (supplied by others) will be required. To determine the prevailing wind speeds for the selected location, refer to <http://windspeed.atcouncil.org/>.

---

**IMPORTANT!** The warranty does not cover damage to the humidifier or property caused by winds in excess of 100 mph (160 km/h).

---

- Allow adequate clearances around the humidifier for ease of maintenance – refer to [Table 4 on page 23](#) for minimum clearances. Observe all local and national installation codes. Nortec is not responsible for any installation code violations.
- Make sure that the structure/surface onto which the humidifier is mounted is stable and suitably reinforced (strength equivalent to 2×4 stud or 1-5/8 in × 1-5/8 in ×12 gauge Unistrut channel) to support the full operating weight of the humidifier – refer to [Table 9 on page 57](#) for weights.

### Steam and Condensate Lines:

- When choosing the location of the humidifier, install it as close as possible to the steam distributor to minimize heat loss through the steam line. The steam line can be connected directly to an AHU or routed through a pipe chase into the building.
- Make sure that the selected location permits proper routing of the steam and condensate lines – refer to the Nortec EL/RS manuals for details. The number of bends and the length of the line must be kept to a minimum so that the total system backpressure does not exceed 5.5 in H<sub>2</sub>O (1.37 kPa).
- The steam line should be routed in such a way that it maintains a constant minimum upslope of 10° or downslope of 2°.
- Provision must be made for condensate removal, and suitable care must be taken to ensure lines and trap do not freeze.

## Water Supply

- To ensure proper functioning of the humidifier in cold climates, the water supply line to the humidifier MUST be properly trace heated and insulated to prevent freezing. In addition to the freeze protection valve that is integral to the unit, a normally-open and a normally-closed (NO/NC) valve (or a 3-way normally-closed valve) MUST be installed in the water supply line inside the building. Refer to "[External Freeze Protection System](#)" on page 35 for details of the valve(s).

---

**IMPORTANT!** The warranty does not cover damage to the humidifier due to freezing.

---

- The water supply line to the unit should have a minimum diameter of 1/2 in (13 mm) with a 1/2 in NPT female end. The line should also have a shutoff valve and a union fitting inside the building for ease of maintenance.
- Refer to the Nortec EL/RS manuals for water quality, filtration, temperature and pressure requirements.

## Drainage

- The main drain line connected to the unit should have a minimum inner diameter of 7/8 in (22 mm) for an EL-OC unit, and 1-3/4 in (45 mm) for a RS-OC unit.
- All drain lines from the unit should empty into an air gap funnel that is connected to a dedicated building drain (recommended) with a drainage capacity of at least 2.3 gpm (8.7 L/min) for an EL-OC unit and 6.7 gpm (30 L/min) for a RS-OC unit – per steam cylinder. All drain lines from the humidifier can empty into a single air gap funnel. **Note:** In large units with two steam cylinders, separate air gap funnels must be used for drain lines from each cylinder.
- Some units use a drain pump. Refer to the Nortec EL/RS manuals for drainage rates and pressure requirements.
- The drain line should be capable of handling water temperatures up to 200 °F (93 °C). During normal operations the maximum temperature of discharge water is 140 °F (60 °C).
- In cold climates all drain lines MUST be properly trace heated and insulated to prevent freezing.

---

**IMPORTANT!** The warranty does not cover damage to the humidifier due to freezing.

---

## Power Supply

- The power supply to the humidifier should be adequate to match the full voltage and current draw shown on the specification label of the humidifier – refer to [Figure 3 on page 9](#) for location of the label.
- The power supply MUST have an external dedicated fused disconnect switch in the immediate vicinity of the unit. The fusing must not exceed the maximum circuit protection indicated on the specification label.

## 5.4 Mounting the Humidifier

### 5.4.1 Location and Suggested Clearances

The location of the Nortec EL/RS Outdoor humidifier depends largely on the location of the steam distributor and the preferred mounting arrangement. [Figure 8 on page 22](#) and [Table 4 on page 23](#) show the suggested minimum clearances regardless of the mounting arrangement selected. The clearance values shown are for reference only, and are suggested clearances for ease of maintenance. Consult local and national installation codes. Nortec does not accept responsibility for violations of the installation codes.

**Note:** Although an overhead clearance is not required for operation of the Nortec EL/RS Outdoor humidifier, adequate overhead clearance must be provided to permit installation of the unit.

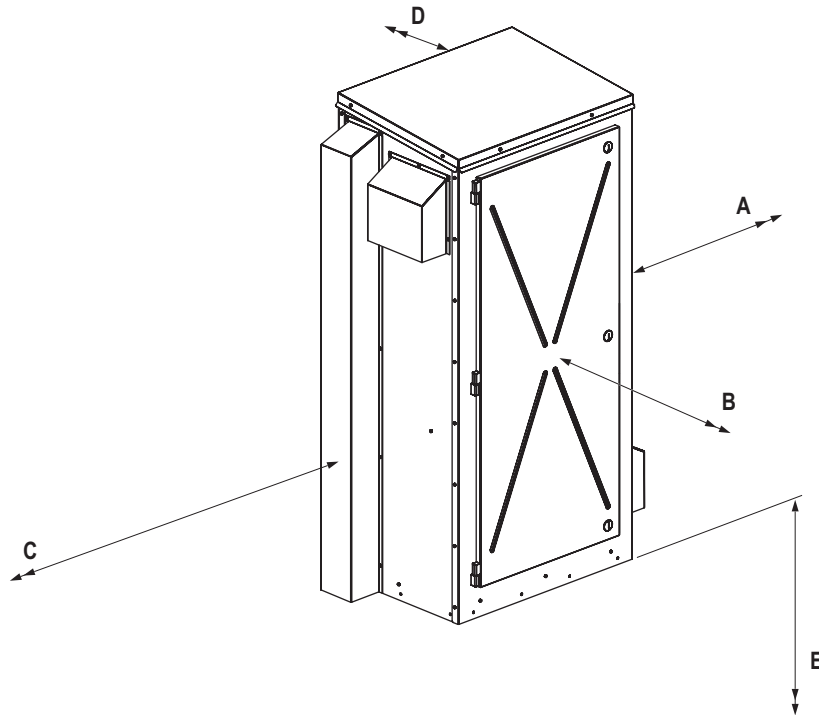

Figure 8: Nortec EL/RS Outdoor Humidifier Suggested Minimum Clearances

Table 4: Nortec EL/RS Outdoor Humidifier Suggested Minimum Clearances

Housing Size	Nortec Model	Suggested Minimum Clearances in (mm)				
		Right Side "A"	Front "B"	Left Side "C"	Back "D" *	Ground/ Roof "E" **
Small	EL-OC 005-050	36 (914)	36 (914)	36 (914)	12 (300)	15 (380)
Medium	EL-OC 050-100 and RS-OC 010-090	36 (914)	36 (914)	36 (914)	12 (300)	15 (380)
Large	EL-OC 150-200*** and RS-OC 90-180***	36 (914)	36 (914)	36 (914)	12 (300)	15 (380)

\* Applies only to units mounted on a rooftop curb

\*\* Minimum clearance. **Note:** In units operating in cold climates, the area around the unit must kept clear of snow and ice accumulation to permit opening and closing of the front and side doors.

\*\*\* Units with two steam cylinders

## 5.4.2 Pipe Chase Location

All external drain lines and water supply line must be routed through suitable pipe chases. Refer to [Figure 9](#) for the general locations of the pipe chases.

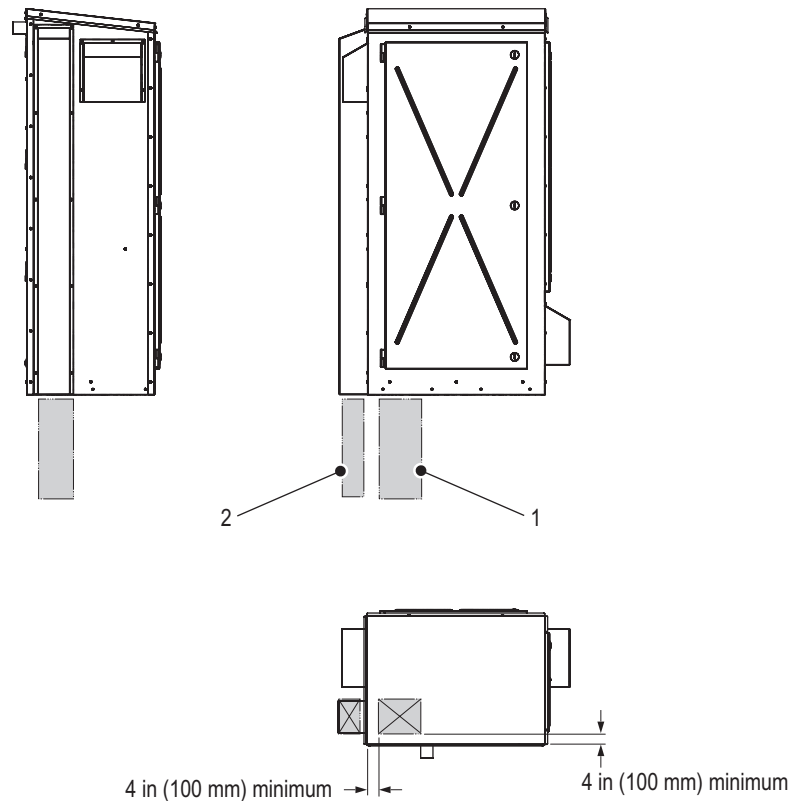

Figure 9: Pipe Chase Location

- 1 Pipe chase (water supply line)
- 2 Pipe chase (drain lines)

### 5.4.3 Air Handling Unit Mounting

Refer to the installation overview in [Figure 5 on page 14](#) and required clearances in "[Location and Suggested Clearances](#)" on [page 22](#), then mount the humidifier on the air handling unit as follows:

1. Select a location where the unit is not exposed to severe weather, or where the temperature drops below -40 °F (-40 °C), and where the wind speed does not exceed 100 mph (160 km/h). External bracing (supplied by others) will be required when wind speed exceeds 100 mph (160 km/h).

---

**IMPORTANT!** The warranty does not cover damage to the humidifier or property caused by winds in excess of 100 mph (160 km/h).

---

2. Select a reasonably flat, non-vibrating vertical mounting surface on the air handling unit that is suitably reinforced (strength equivalent to 2x4 stud or 1-5/8 in x 1-5/8 in x 12 gauge Unistrut channel), and capable of supporting the full operating weight of the humidifier – refer to [Table 9 on page 57](#) for weights.
3. Mark the attachment points "A" and "B" at the desired position with the help of a level. Refer to [Figure 10 on page 25](#) and [Table 5 on page 24](#).
4. Mark the location of the cutout "C" for the steam line, and cut out a suitable size opening in the air handling unit. Refer to "[Dimensions](#)" on [page 58](#) for the size of the steam outlet.
5. Secure the mounting bars to the air handling unit with four 1/4-20 UNC bolts (supplied by others). Make sure that the mounting bars are level, and tighten the bolts.
6. Install suitably sized pipe chases for the drain lines and water supply line – refer to [Figure 9 on page 23](#) for general locations.
7. Remove the shipping straps, the packaging crate and the foam spacers around the unit. Then remove the shipping screws that secure the unit to the shipping skid, and carefully slide the unit to the rear of the skid so that the unit is flush with the edge of the skid.
8. Install the shipping screws and secure the unit to the shipping skid again.



**WARNING!**  
**Heavy object – risk of personal injury and damage to equipment!**

**Prevention:** While the unit is still attached to the shipping skid, raise the humidifier using a forklift or crane. Protect the unit from damage by tethers and other lifting equipment, and do not drop the humidifier.

---

9. Carefully raise the humidifier into position and align the mounting brackets on the back of the humidifier with the installed mounting bars, as shown. Lower the humidifier onto the mounting bars, and make sure that the unit is seated properly and level.
10. Secure the humidifier to the mounting surface at attachment point(s) "B" with 1/4-20 UNC bolt(s) (supplied by others). Tighten the bolt(s).
11. Seal the opening in the air handling unit around the steam line.
12. Remove the shipping screws and the shipping skid from the bottom of the unit.

*Table 5: Holes Spacing*

Housing Size	Dimension in (mm)										
	X1	X2*	X3	X4	X5	X6	Y1**	Y2	Y3*	Y4	Y5
Small	4.21 (107)	4.00 (102)	6.36 (162)	–	10.21 (259)	–	15.00 (381)	15.13 (384)	16.00 (406)	36.75 (933)	0.95 (24)
Medium	2.67 (68)	4.00 (102)	8.55 (217)	–	12.67 (322)	–	15.00 (381)	15.88 (403)	16.00 (406)	52.34 (1329)	4.50 (114)
Large	6.22 (158)	4.00 (102)	9.07 (230)	14.30 (363)	10.07 (256)	24.30 (617)	15.00 (381)	15.88 (403)	16.00 (406)	52.34 (1329)	9.00 (229)

\* Typical  
 \*\* Minimum clearance

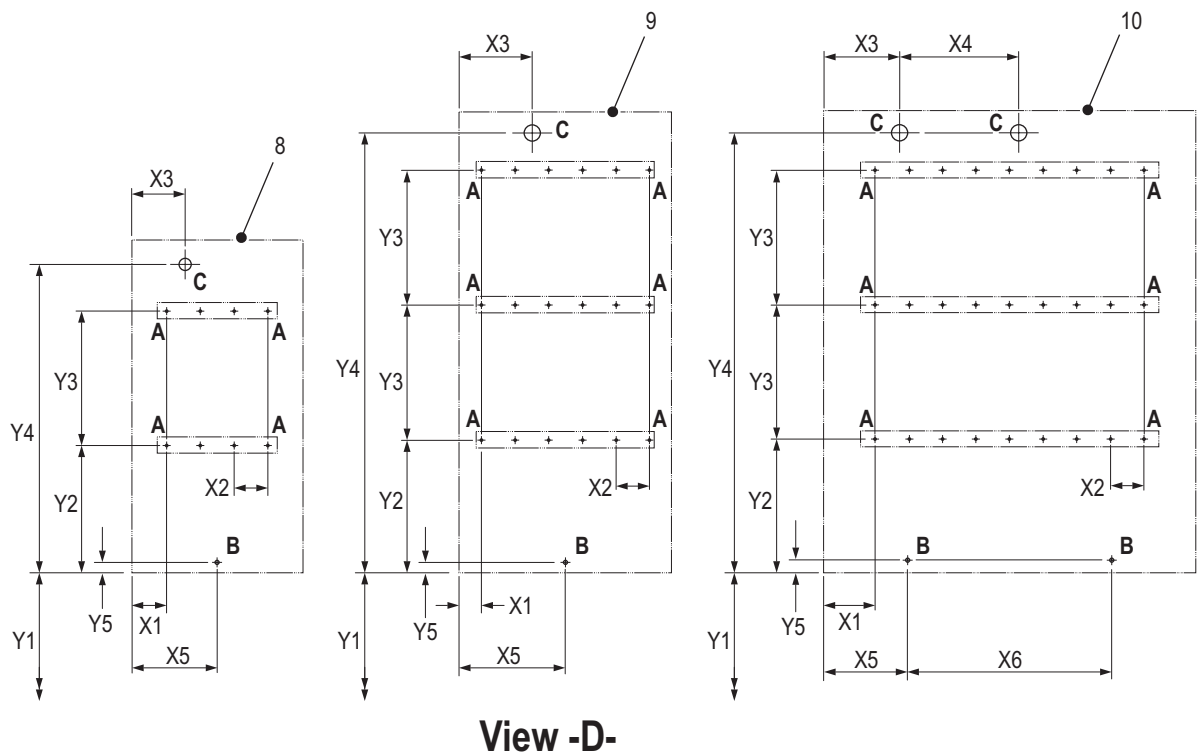

**View -D-**

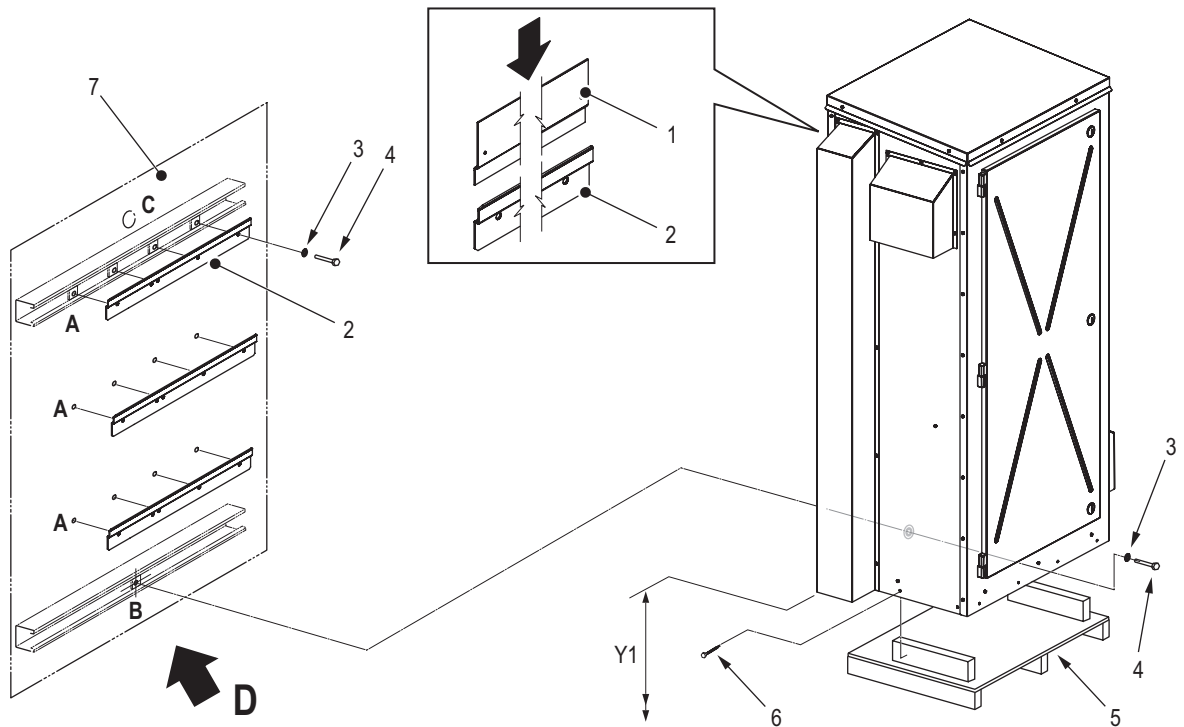

**Figure 10: Air Handling Unit Mounting**

- |   |  |    |  |
|---|--|----|--|
| 1 | Mounting bracket, attached to the humidifier rear panel<br>(×2 for small unit, ×3 for medium and large unit) | 6  | Screw (used for shipping)                                  |
| 2 | Mounting bar, supplied (×2 for small unit, ×3 for medium and large unit)                                     | 7  | Mounting surface, air handling unit                        |
| 3 | Flat washer, 1/4 in diameter (supplied by others)  | 8  | Outline of unit's rear panel – small size unit, reference  |
| 4 | Bolt, 1/4-20 UNC (supplied by others)  | 9  | Outline of unit's rear panel – medium size unit, reference |
| 5 | Shipping skid  | 10 | Outline of unit's rear panel – large size unit, reference  |

## 5.4.4 Rooftop Curb Mounting

Refer to the installation overview in [Figure 6 on page 16](#) and required clearances in "[Location and Suggested Clearances](#)" on [page 22](#), then install the humidifier on the rooftop curb as follows:

1. Select a location where the unit is not exposed to severe weather, or where the temperature drops below -40 °F (-40 °C), and where the wind speed does not exceed 100 mph (160 km/h). External bracing (supplied by others) will be required when wind speed exceeds 100 mph (160 km/h).

---

**IMPORTANT!** The warranty does not cover damage to the humidifier or property caused by winds in excess of 100 mph (160 km/h).

---

2. Choose the location of the curb on the rooftop so that the humidifier is as close as possible to the steam distributor.
3. Construct the curb to the dimension shown in [Figure 11 on page 27](#) and [Table 6](#). Make sure that the curb is capable of supporting the full operating weight of the unit – refer to [Table 9 on page 57](#).

---

**IMPORTANT!** Make sure that the curb is properly anchored to the rooftop.

---

4. Cut suitably sized openings in the roof and install pipe chases – refer to [Figure 9 on page 23](#) for general locations.
5. Remove the shipping straps, the packaging crate and the foam spacers around the unit, but DO NOT remove the screws at the bottom that secure the unit to the shipping skid.



**WARNING!**  
Heavy object – risk of personal injury and damage to equipment!

**Prevention:** While the unit is still attached to the shipping skid, raise the humidifier using a forklift or crane. Protect the unit from damage by tethers and other lifting equipment, and do not drop the humidifier.

---

6. Carefully lower the unit onto the curb, then remove the shipping screws and the shipping skid from the bottom of the unit.
7. Make sure the unit is seated properly and level on the curb, and fasten the unit securely to the curb using suitable 1/4 in (6 mm) diameter fasteners (supplied by others) through all the pre-drilled holes in the base of the unit.

Table 6: Curb Dimensions

Housing Size	Dimension in (mm)		
	X	Y	Z
Small	20.1 (511)	13.3 (338)	15 (380)
Medium	25.1 (638)	18.1 (460)	15 (380)
Large	41.1 (1044)	18.1 (460)	15 (380)

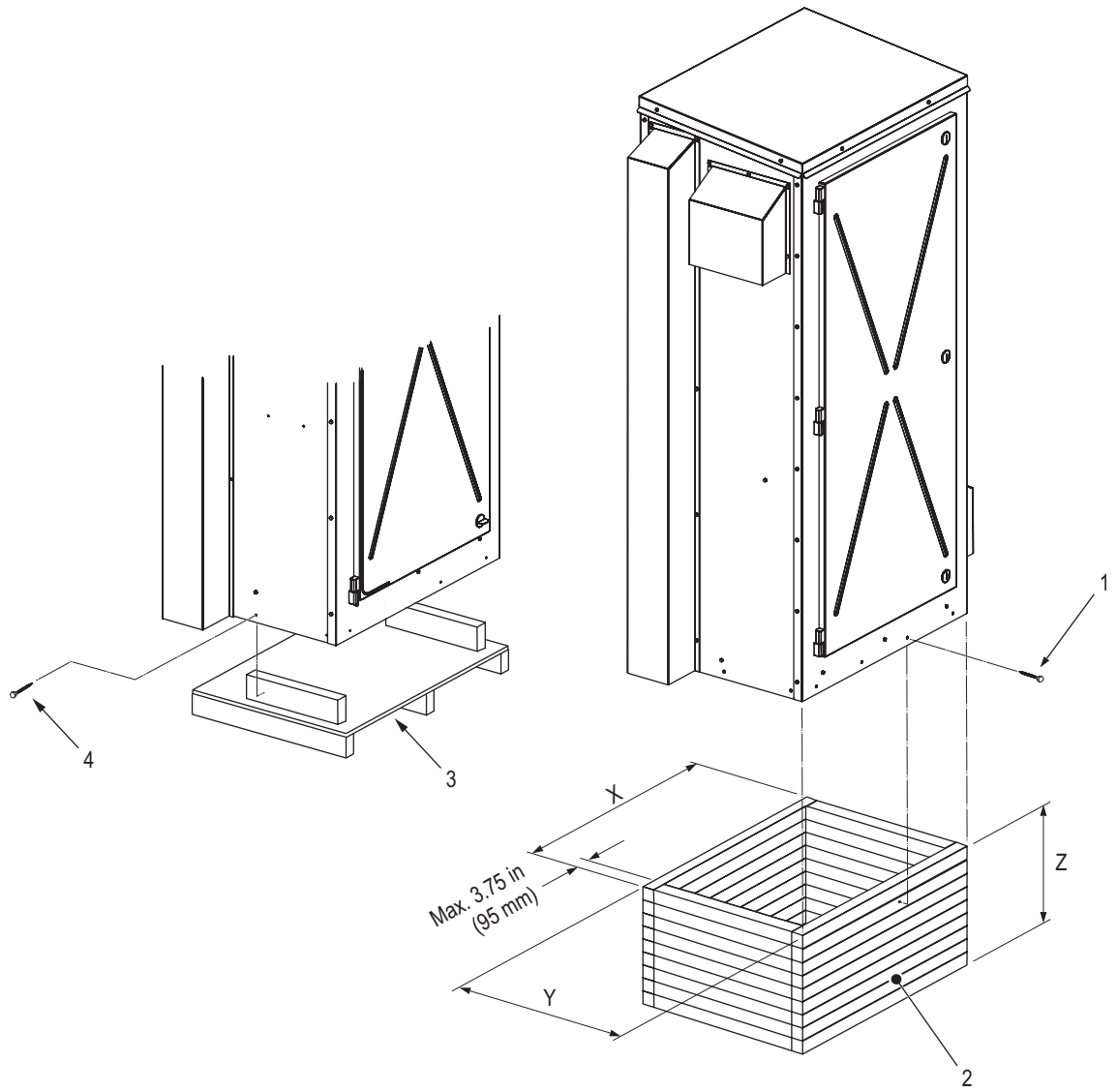

*Figure 11: Rooftop Curb Mounting*

- 1 Fastener (supplied by others)
- 2 Curb
- 3 Shipping skid
- 4 Screw (used for shipping)

## 5.4.5 Exterior Wall Mounting

Refer to the installation overview in [Figure 7 on page 18](#) and required clearances in "[Location and Suggested Clearances](#)" on [page 22](#), then install the humidifier on an exterior wall as follows:

1. Select a location where the unit is not exposed to severe weather, or where the temperature drops below -40 °F (-40 °C), and where the wind speed does not exceed 100 mph (160 km/h). External bracing (supplied by others) will be required when wind speed exceeds 100 mph (160 km/h).

**IMPORTANT!** The warranty does not cover damage to the humidifier or property caused by winds in excess of 100 mph (160 km/h).

2. Select a reasonably flat vertical mounting surface on a suitably reinforced exterior wall (strength equivalent to 2×4 stud or 1-5/8 in × 1-5/8 in × 12 gauge Unistrut channel) that is capable of supporting the full operating weight of the humidifier – refer to [Table 9 on page 57](#) for the weight.
3. Mark the attachment points "A" and "B" at the desired position with the help of a level. Refer to [Figure 12 on page 29](#) and [Table 7](#).
4. Mark the location of the cutout "C" for the steam line, and cut out a suitable size opening in the exterior wall. Refer to "[Dimensions](#)" on [page 58](#) for the size of the steam outlet.
5. Secure the mounting bars to the mounting surface with four 1/4-20 UNC bolts (supplied by others). Make sure that the mounting bars are level, and tighten the bolts.
6. Install suitably sized pipe chases for the drain lines and water supply line – refer to [Figure 9 on page 23](#) for general locations.
7. Remove the shipping straps, the packaging crate and the foam spacers around the unit. Then remove the shipping screws that secure the unit to the shipping skid, and carefully slide the unit to the rear of the skid so that the unit is flush with the edge of the skid.
8. Install the shipping screws and secure the unit to the shipping skid again.



**WARNING!**

**Heavy object – risk of personal injury and damage to equipment!**

**Prevention:** While the unit is still attached to the shipping skid, raise the humidifier using a forklift or crane. Protect the unit from damage by tethers and other lifting equipment, and do not drop the humidifier.

9. Carefully raise the humidifier into position and align the mounting brackets on the back of the humidifier with the installed mounting bars, as shown. Lower the humidifier onto the mounting bars, and make sure that the unit is seated properly and level.
10. Secure the humidifier to the mounting surface at attachment point(s) "B" with 1/4-20 UNC bolt(s) (supplied by others). Tighten the bolt(s).
11. Seal the opening in the wall around the steam line.
12. Remove the shipping screws and the shipping skid from the bottom of the unit.

*Table 7: Holes Spacing*

Housing Size	Dimension in (mm)										
	X1	X2*	X3	X4	X5	X6	Y1**	Y2	Y3*	Y4	Y5
Small	4.21 (107)	4.00 (102)	6.36 (162)	–	10.21 (259)	–	15.00 (381)	15.13 (384)	16.00 (406)	36.75 (933)	0.95 (24)
Medium	2.67 (68)	4.00 (102)	8.55 (217)	–	12.67 (322)	–	15.00 (381)	15.88 (403)	16.00 (406)	52.34 (1329)	4.50 (114)
Large	6.22 (158)	4.00 (102)	9.07 (230)	14.30 (363)	10.07 (256)	24.30 (617)	15.00 (381)	15.88 (403)	16.00 (406)	52.34 (1329)	9.00 (229)

\* Typical

\*\* Minimum clearance

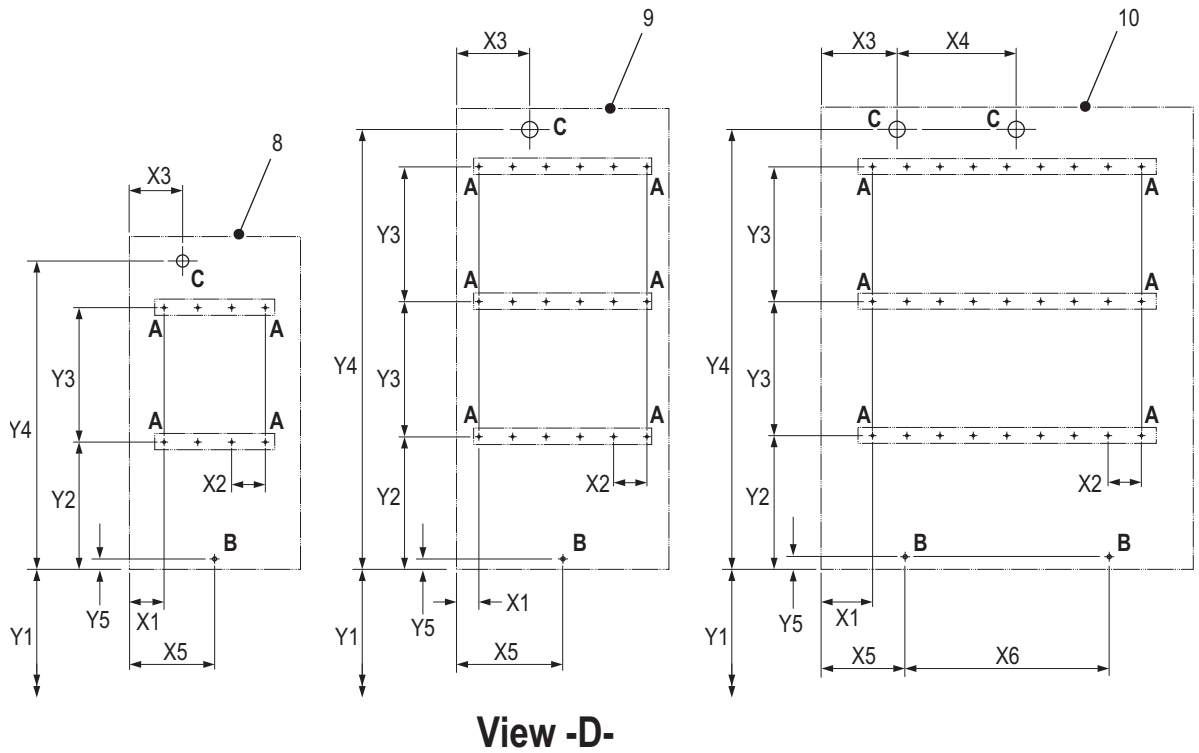

**View -D-**

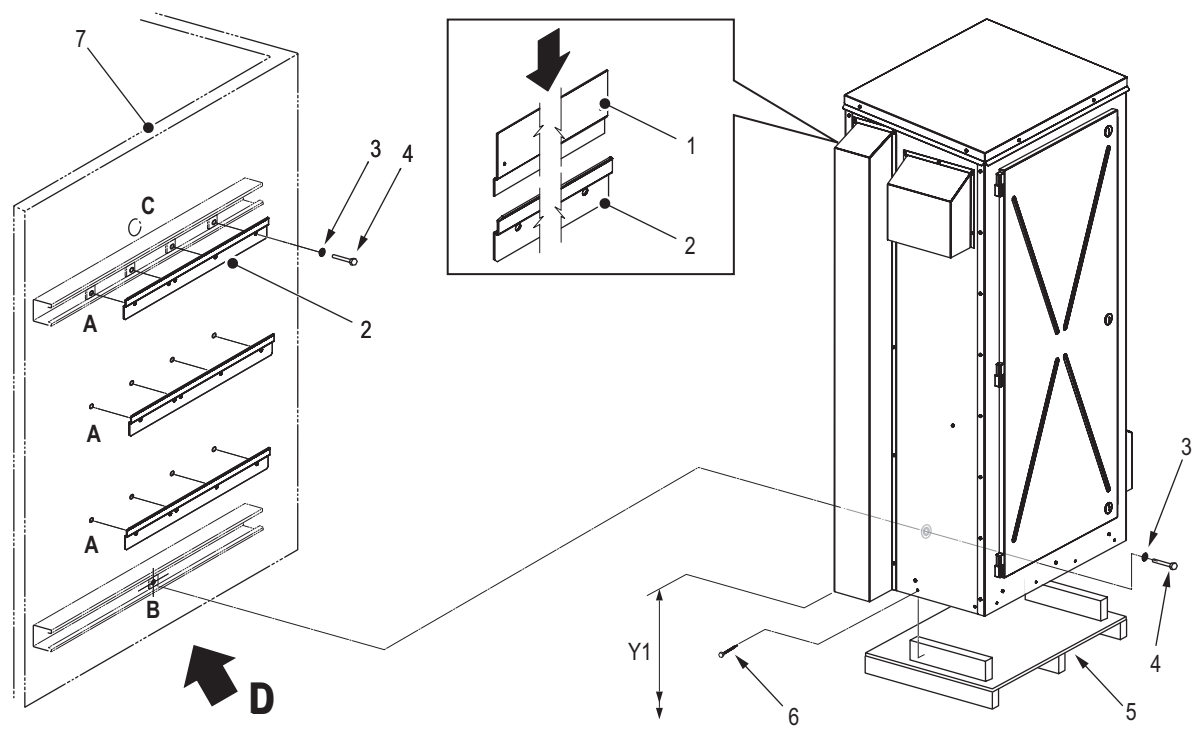

**Figure 12: Exterior Wall Mounting**

- 1 Mounting bracket, attached to the humidifier rear panel (×2 for small unit, ×3 for medium and large unit)
- 2 Mounting bar, supplied (×2 for small unit, ×3 for medium and large unit)
- 3 Flat washer, 1/4 in diameter (supplied by others)
- 4 Bolt, 1/4-20 UNC (supplied by others)
- 5 Shipping skid
- 6 Screw (used for shipping)
- 7 Mounting surface, external wall
- 8 Outline of unit's rear panel – small size unit, reference
- 9 Outline of unit's rear panel – medium size unit, reference
- 10 Outline of unit's rear panel – large size unit, reference

## 5.4.6 Mounting Checklist

After mounting the humidifier, check the following:

- Unit mounted in an outdoor environment where it is not exposed to severe weather, or where the temperature drops below  $-40\text{ }^{\circ}\text{F}$  ( $-40\text{ }^{\circ}\text{C}$ ), and where the wind speed does not exceed 100 mph (160 km/h)?
- Adequate clearances maintained (according to "[Location and Suggested Clearances](#)" on page 22, and all local and national installation codes)?
- Mounting surface stable and reinforced to support the full operating weight of the humidifier?
- Unit level?
- Unit fastened securely?

## 5.5 Steam Line Connections

### 5.5.1 Steam Line

The steam outlet is located on the rear of the Nortec EL/RS Outdoor humidifier – refer to [Figure 2 on page 8](#). Steam hose(s) and clamps are supplied to permit connection to the steam line into the building.

Refer to the Nortec EL/RS manuals for steam and condensate line routing and connection details, as well as sizing and materials. The number of bends and the length of the line must be kept to a minimum so that the total system backpressure (backpressure in the line plus duct static pressure) does not exceed 5.5 in H<sub>2</sub>O (1.37 kPa).

The steam lines can be routed to an air handling unit or through a pipe chase in the roof or exterior wall into the building.

The steam lines must maintain a constant minimum upslope of  $10^{\circ}$  or downslope of  $2^{\circ}$ , and must be insulated. If the steam line runs upward, a condensate trap must be installed at the location where the steam exits the unit – refer to [Figure 13](#). The condensate line and trap MUST be trace heated to prevent freezing.

All steam lines MUST be insulated to minimize condensation and maximize efficiency.

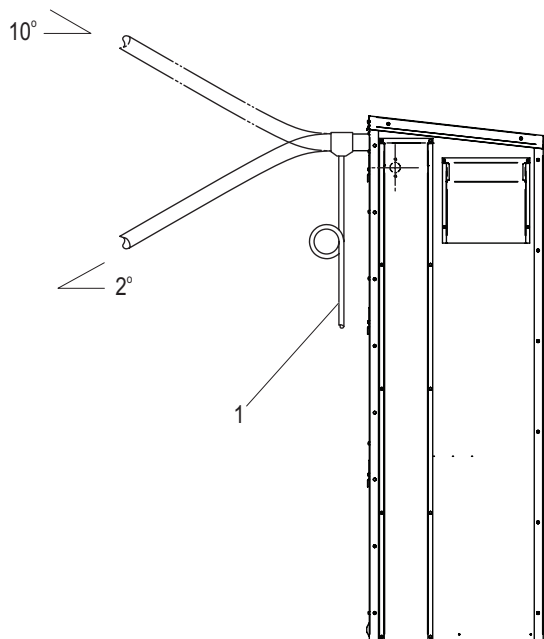

*Figure 13: Condensate Drain at Steam Exit*

- 1 Condensate trap (on steam line running upward)

## 5.5.2 Steam Connections Checklist

Check the following to ensure that the steam and condensate connections for the outdoor humidifier have been installed properly.

### Steam Line

- Total system backpressure does not exceed 5.5 in H<sub>2</sub>O (1.37 kPa)?
- Steam line maintain constant minimum upslope of 10° or downslope of 2°? If steam line runs upward, is a condensate trap installed at the location where the steam exits the unit? Condensate line and trap trace heated?
- Steam line sized correctly, and does not exceed maximums specified in the Nortec EL/RS manuals?
- Minimum bend radius of 12 in (300 mm) for steam hose, or 5× internal diameter for rigid pipes maintained?
- Steam line does not reduce in diameter except at the steam distributor? Condensate line installed just before the restriction?
- Steam lines do not merge except at the steam distributor through a Nortec adaptor?
- Steam line does not sag or kink? Supported adequately? Condensate trap installed at all low points in line?
- If a steam hose is used, is it attached securely with clamps? Clamps secure without crushing steam line?
- Allowances for thermal expansion during operation, and shortening of the hose due to aging taken into consideration?
- Steam line properly insulated?
- Steam line purged?

### Condensate Lines

- Drain water temperature meet local code requirements?
- Condensate line from the steam distributor condensate port connected to the humidifier fill cup port, or the drain?
- Condensate lines installed at all low points, and at horizontal -to-vertical transitions in the steam line?
- Condensate lines in the steam line always connect to full-size "T" connectors?
- Condensate traps have a minimum loop height of 8 in (200 mm) and installed at least 12 in (300 mm) below the "T" connector or steam distributor?
- All condensate lines have a constant minimum downslope of 1 in/48 in (1.2°)?
- Maximum distance between the condensate traps on long runs 15 ft (4.5 m)?
- Condensate lines free of kinks?
- Condensate lines purged?
- Condensate traps primed with water?



Legend:

- 1 Mechanical freeze protection valve
- 2 Flexible bent hose and clamp, 1-3/16 in (30 mm) I.D. (supplied)
- 3 Drain cup (EL-OC)
- 4 Drain cup (RS-OC)
- 5 Drain line, 1-3/16 in (30 mm) I.D. (supplied by others)
- 6 Bottom panel
- 7 Knockout (spare)
- 8 Drain line, 3/8 in (9.5 mm) I.D. (mechanical freeze protection valve)
- 9 Mechanical freeze protection valve (RS-OC with scale tank only)
- 10 Trace heating and insulation (supplied by others)
- 11 Air gap funnel (supplied by others)
- 12 Filter, 5 µm (optional, but recommended)
- 13 Shutoff valve (supplied by others)
- 14 Union fitting (supplied by others)
- 15 3-way normally-closed valve, or normally-open and normally-closed valves (supplied by others)
- 16 Trace heating and insulation (supplied by others)
- 17 Water supply line, minimum 1/2 in (13 mm) (supplied by others)
- 18 Adaptor, 3/4 BSPP to 1/2 in NPT (supplied)
- 19 Inlet, fill valve (3/4 in BSPP plastic threads)

## Water Supply Line

- The water supply must be installed to local plumbing codes.
- In cold climates make sure that an external freeze protection system (utilizing either a normally-open and a normally-closed valve, or a 3-way normally-closed valve – supplied by others) is installed inside the building to protect the water supply line from freezing. Refer to ["External Freeze Protection System" on page 35](#).

---

**IMPORTANT!** The warranty does not cover damage to the humidifier resulting from freezing.

---

- For ease of maintenance, make sure that a water shutoff valve and union fitting are installed in the supply line (inside the building), as close as possible to the humidifier.
- The water filter (optional, but recommended) must be installed on the inside of the building as close as possible to the humidifier.
- The water supply line should be minimum 1/2 in (13 mm) in diameter, and have a 1/2 in NPT female end.
- Route the water supply line through a pipe chase to the unit. In cold climates, install trace heating and insulation to prevent the line from freezing.



**CAUTION!**

**Risk of damage to the plastic threads of the fill valve!**

**Prevention:** Hand-tighten the NPT adaptor to the fill valve.

---

- Install the NPT adaptor and O-ring (supplied) on the fill valve and hand-tighten. Connect the water supply line to the adaptor.

## Drain Lines

- Make sure that the air gap funnel is located inside the building, and connected to a dedicated building drain (recommended) with a drainage capacity of at least 2.3 gpm (8.7 L/min) for an EL-OC unit and 6.7 gpm (30 L/min) for a RS-OC unit – per steam cylinder. The drain line exiting the funnel should be minimum 7/8 in (22 mm) in diameter for an EL-OC unit, and minimum 1-3/4 in (45 mm) for a RS-OC unit. In large units, separate air gap funnels must be used for drain lines from each cylinder.
- All drain lines described below should be as short as possible, and routed through a pipe chase. Drain lines must have a constant minimum downslope of 1 in/48 in (1.2°) and empty into the funnel

without touching its sides or bottom.

- Route a drain line (supplied by others) with an inside diameter of 1-3/16 in (30 mm) through the large hole in the bottom panel and connect it to the flexible bent hose (supplied) exiting the humidifier – refer to [Figure 14 on page 32](#). Secure the line with clamps (supplied). Route the other end of the drain line to the air gap funnel.
- Route the 3/8 in (9.5 mm) I.D. drain hose from the mechanical freeze protection valve (and scale tank in RS-OC units) through the small hole in the bottom panel to the air gap funnel, as shown.
- In cold climates, install trace heating and insulation to prevent the drain lines from freezing.
- All drain lines must be installed to local plumbing codes.

Upon completion of the water and drain connections, perform the following:

- To ensure that the IP54 rating of the unit is maintained, seal all gaps around the drain lines where they pass through the bottom panel in the unit.

---

**IMPORTANT!** Seal all pipe chases to prevent any rising steam from entering the bottom of the unit, and to isolate the unit from the pressure inside the building.

---

- Disconnect and flush the water supply and drain lines to clear out any debris in the lines. Check the strainer in the fill valve to ensure it is clear of all debris (refer to the Nortec EL/RS manuals for details). Reconnect the lines.

## 5.6.2 External Freeze Protection System

In cold climates, the external freeze protection system (supplied by others) is an important part of the protection for the Nortec EL/RS Outdoor humidifier against freezing. The external freeze protection system must be installed correctly and fully functional at all times.

---

**IMPORTANT!** The warranty does not cover damage to the humidifier resulting from freezing.

---

### 5.6.2.1 Normally-Open and Normally-Closed Valves

This arrangement consists of a normally-open and a normally-closed valve installed inside the building to protect the water supply line from freezing. Refer to [Figure 15](#).

The water supply flows to the fill valve through the normally-closed valve and a tee. This valve remains closed unless it is energized by the humidifier. This stops the water flow into the humidifier when there is no demand, or in the event of a power failure.

At the same time, a normally-open valve which is also connected to the tee remains open unless it is energized by the humidifier. This allows any water in the line (from the tee to the fill valve) to drain as long as there is no demand on the humidifier, or in the event of a power failure.

The electrical connections are shown in [Figure 15](#).

When there is a demand for humidity, the normally-closed valve opens, and the normally-open valve closes to permit water flow to the fill valve.

In the event the temperature of the water in the (trace heated) line drops below 35 °F (2 °C), the bi-metal strip (supplied by others) interrupts the circuit, and the water supply to the unit is shut off. Any water in the line is then allowed to drain.

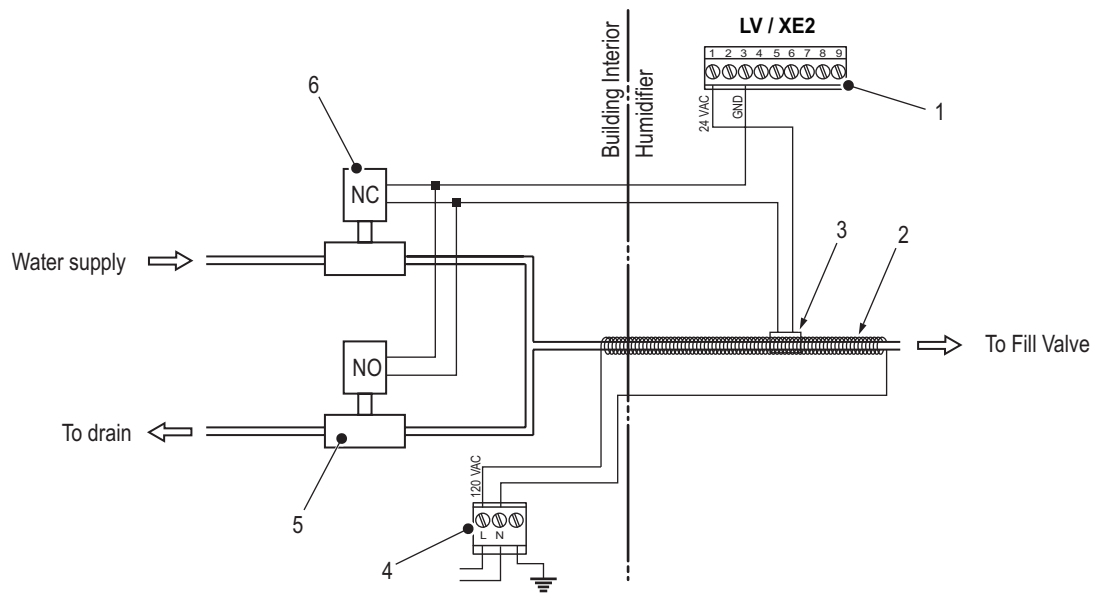

*Figure 15: Normally-Open and Normally-Closed Valve Arrangement*

- 1 Low voltage terminal strip in the humidifier (LV / XE2)
- 2 Trace heating (supplied by others), minimum 37-41 °F (3-5 °C)
- 3 Bi-metal strip (supplied by others) set to 35 °F (2 °C) and installed around the trace heated pipe
- 4 120 VAC exterior power supply, trace heating (supplied by others)
- 5 24 V normally-open valve (supplied by others)
- 6 24 V normally-closed valve (supplied by others)

### 5.6.2.2 3-Way Normally-Closed Valve

This arrangement consists of a normally-closed 3-way valve (instead of the "Normally-Open and Normally-Closed Valves" on page 35) installed inside the building to protect the water supply line from freezing. Refer to [Figure 16](#).

The water supply flows to the fill valve when the 3-way valve is energized by the humidifier. When there is no demand, or in the event of a power failure, the valve is de-energized and the water in the line is allowed to drain.

The electrical connections are shown in [Figure 16](#).

In the event the temperature of the water in the (trace heated) line drops below 35 °F (2 °C), the bi-metal strip (supplied by others) interrupts the circuit and the water supply to the unit is shut off. Any water in the line is then allowed to drain.

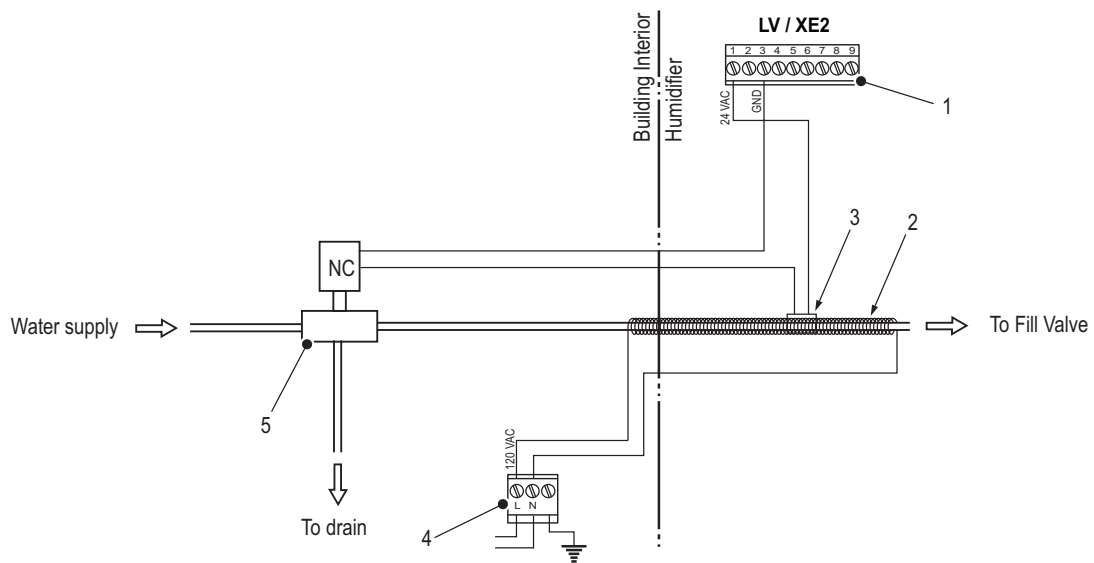

**Figure 16: 3-Way Normally-Closed Valve Arrangement**

- 1 Low voltage terminal strip in the humidifier (LV / XE2)
- 2 Trace heating (supplied by others), minimum 37-41 °F (3-5 °C)
- 3 Bi-metal strip (supplied by others) set to 35 °F (2 °C) and installed around the trace heated pipe
- 4 120 VAC exterior power supply, trace heating (supplied by others)
- 5 24 V normally-closed 3-way valve (supplied by others)

### 5.6.3 Water Connections Checklist

Check the following to ensure that the water connections for the outdoor humidifier have been installed properly.

- Water and drain lines installed to local plumbing codes?
- Shutoff valve and union fitting installed in supply line?
- Water supply piping minimum 1/2 in (13 mm) diameter, and routed through a pipe chase to the unit?
- Optional 5 µm water filter installed in the water supply line (inside the building) close to the humidifier?
- Water supply surge-free and pressure regulated to 30-80 psig (207-550 kPa)?
- Water temperature 34-104°F (1-40°C) for EL-OC unit, and 140°F (60°C) for RS-OC unit?
- Cold potable drinking water only (not RO or DI) for EL-OC unit?
- For EL-OC unit, is conductivity of the water 150-1200 micro-seimens/cm, hardness 0-12 gpg (when Silica is between 0-4 ppm), or 0-3 gpg (when Silica is between 4-14 ppm), and pH 7-7.5?
- For RS-OC unit, is conductivity of the water 1-1500 micro-seimens/cm, hardness 0-12 gpg, Silica 0-12 ppm, pH 6.5-7.5 pH, and chloride 0-50 ppm?
- If the unit is installed in a cold climate, are the freeze protection valves (normally-open and a normally-closed valve, or a 3-way normally-closed valve) installed inside building?
- All drain lines routed through the bottom panel in the unit through a pipe chase to the air gap funnel?
- All gaps around the drain lines sealed where they pass through the bottom panel in the unit?
- Drain lines have a constant minimum downslope of 1 in/48 in (1.2°) to funnel without touching its sides or bottom?
- Drain lines from large humidifiers empty into separate air gap funnels before connecting to the building drain?
- Air gap funnel(s) connected to a dedicated building drain (recommended) with a drainage capacity of at least 2.3 gpm (8.7 L/min) for an EL-OC unit and 6.7 gpm (30 L/min) for a RS-OC unit – per steam cylinder?
- Drain line exiting the funnel minimum 7/8 in (22 mm) in diameter for an EL-OC unit, and minimum 1-3/4 in (45 mm) for a RS-OC unit?
- If the unit is installed in a cold climate, are the water supply and drain lines trace heated and insulated?
- All pipe chases sealed to isolate the unit from pressure inside the building?
- Any leaks?
- Supply and drain lines flushed to remove all debris? Strainer in the fill valve clear of all debris?

## 5.7 Electrical Connections



**DANGER!**  
Risk of electric shock!

**The Nortec EL/RS Outdoor humidifier is mains powered. Live parts may be exposed when the doors are open. Touching live parts may cause severe injury or even death.**

**Prevention:** All electrical work must only be performed by a licensed electrician. The humidifier must be connected to the mains only after all installation work has been completed, checked for correct workmanship, and the doors are closed and fastened securely.



**CAUTION!**  
Electrostatic discharge (ESD)!

**The electronic components inside the humidifier are sensitive to electrostatic discharge (ESD).**

**Prevention:** Take appropriate measures to protect the electronic components inside the unit against damage caused by electrostatic discharge (ESD). Refer to ANSI/ESD-S20.20.

- All wiring must be performed by a licensed electrician in accordance with national and local codes.
- Make sure that power supply voltage and current ratings match the requirements shown on the specification label (refer to [Figure 2 on page 8](#)).
- All electrical cables MUST enter the side or bottom of the unit through minimum IP54-rated cable glands (supplied by others) to ensure that the IP54 rating for the unit is maintained. Knockouts are available on the side and bottom of the unit for routing the cables into the unit – refer to [Figure 17 on page 39](#).

**Note:** Knockouts for the small unit are located on the left side of the unit.

- A NEMA Type 3R (or greater) weatherproof fused disconnect switch (supplied by others) must be installed external to the unit to permit power interruption for service/maintenance. The fusing must not exceed the maximum circuit protection indicated on the specification label.

**IMPORTANT!** In order to maintain the IP54 rating of the unit, DO NOT mount the disconnect switch, or any other component, directly on the outdoor enclosure of the unit. Such installations may permit entry of moisture into the unit and cause heat loss, and will void the warranty.

- The power cable must be connected to the terminal block (X0). Refer to [Figure 17 on page 39](#) and ["Outdoor Enclosure Wiring Diagram" on page 40](#).
- Connect the external freeze protection valves (supplied by others) to the humidifier's safety circuit as described in ["External Freeze Protection System" on page 35](#).
- For all other electrical connection details (including low voltage control wiring) refer to the Nortec EL/RS manuals.

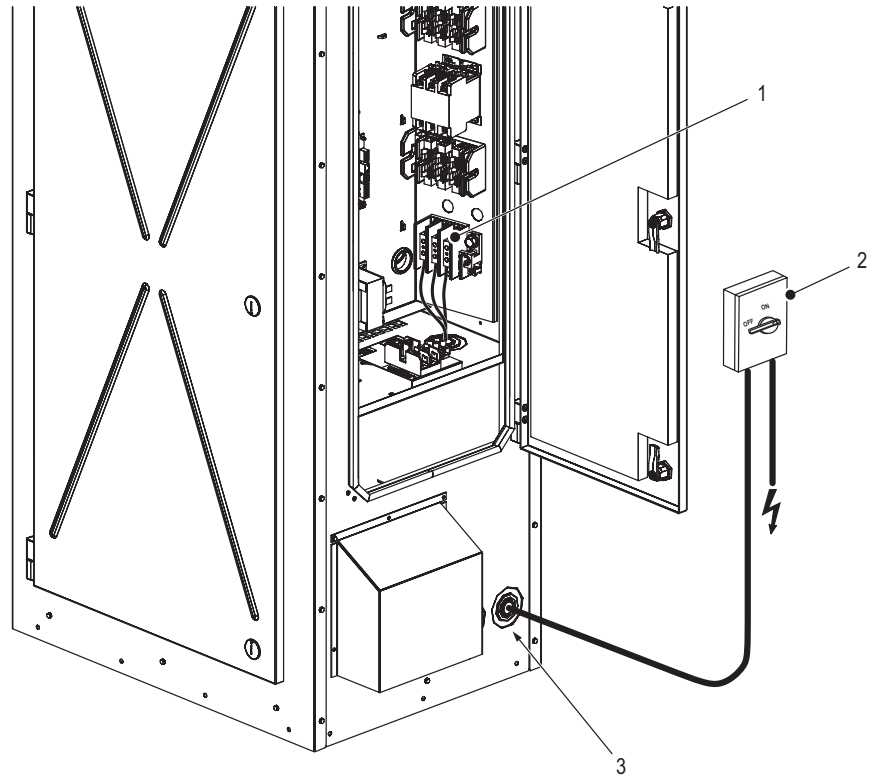

*Figure 17: Nortec EL/RS Outdoor Humidifier Power Connection*

- 1 Terminal block (X0)
- 2 External disconnect switch (NEMA Type 3R or greater)
- 3 Knockout for routing power cable

## 5.7.1 Outdoor Enclosure Wiring Diagram

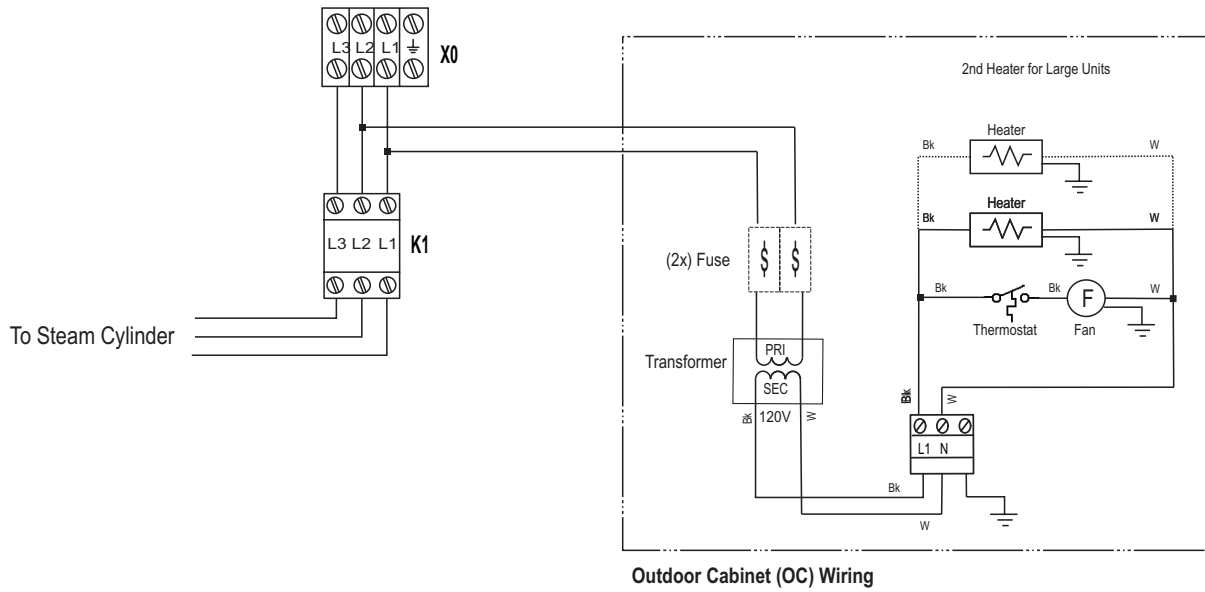

Figure 18: Outdoor Cabinet Wiring Diagram - Nortec EL/RS Outdoor Humidifier

## 5.7.2 Electrical Connections Checklist

Check the following to ensure that the electrical connections for the humidifier have been installed properly:

- Power supply meet the voltage and current requirements shown on the specification label ([Figure 2 on page 8](#))?
- All electrical cables enter the bottom of the unit through minimum IP54-rated cable glands?
- Power supply have a NEMA Type 3R (or greater) weatherproof fused disconnect switch? Fusing rated for maximum circuit protection indicated on the specification label? Disconnect switch installed external to the unit, and NOT directly attached to unit?
- All wiring done according to the wiring diagrams and instructions in this manual?
- Electrical installation meet the applicable national and local codes?

# 6 Commissioning

---

## 6.1 General

The Nortec EL/RS Outdoor humidifier must be commissioned and operated only by personnel who are well qualified and properly trained to commission the Nortec humidifier. It is the customer's responsibility to verify the qualifications of personnel.

## 6.2 Commissioning

The unit must always be commissioned for the first time by a service technician from your Nortec representative, or by personnel who are well trained and authorized by the customer. For the consolidated installation checklist, refer to the ["Installation Checklist" on page v](#).

The steps are in the following order:

1. Inspect the mounting of the outdoor steam humidifier.
2. Inspect the steam and condensate line connections.
3. Inspect the water and drain connections.
4. Inspect the electrical connections.
5. Inspect the external freeze protection system.
6. Flush the water supply and drain lines.
7. Make sure that the steam cylinder is seated properly in its base.
8. Configure the controls and the Nortec EL/RS Outdoor humidifier.
9. Wire the unit to a remote monitoring system, and verify that it is functional.
10. Conduct performance tests, including control and monitoring devices.
11. Fill out the commissioning protocol documents.

This page intentionally left blank

# 7 Operation and Maintenance

---

## 7.1 Operating the Unit

The Nortec EL/RS Outdoor humidifier is operated in the same manner as its indoor counterpart. Refer to respective Nortec EL/Nortec RS operation and maintenance manual for details.

## 7.2 Inspections During Operation

Regularly inspect the following when the unit is in operation:

- Inspect the water, drain and steam connections for any leaks.
- Make sure that the drain lines are not blocked or kinked, and empty into the air gap funnel inside the building.
- Check the unit and other system components have not shifted from their mountings, and are fastened securely.
- Visually check for any damage to the electrical wiring.
- Visually check the heating wires and insulation around the water and drain lines for damage.
- Inspect the heater and fan for buildup of dirt and pollen, and make sure that the air intake and exhaust shrouds are free of all blockages.
- Check the Home screen on the unit for maintenance or alarm messages. **Note:** The remote fault board can also be used to remotely monitor the unit for maintenance or alarm messages.
- Check that the doors on the unit are closed and fastened securely.
- In units operating in cold climates, inspect the external freeze protection system and make sure that it is fully functional at all times. Refer to ["Freeze Protection System" on page 44](#).
- In units operating in cold climates, keep the area around the unit clear of snow and ice accumulation to permit opening and closing of the front and side doors.

## 7.3 Maintenance

### 7.3.1 General

To ensure proper performance and long operating life of the Nortec EL/RS Outdoor humidifier, Nortec recommends inspection of the appliance and installation at least once a year by a qualified service person.



**DANGER!**  
Risk of electric shock!

**The Nortec EL/RS Outdoor humidifier is mains powered. Live parts may be exposed when the door panels are opened. Touching live parts may cause severe injury or even death.**

**Prevention:**

Shut down the Nortec EL/RS Outdoor humidifier properly and disconnect power to the unit before performing any maintenance work on the unit – refer to the respective Nortec EL/Nortec RS operation and maintenance manual for proper shutdown procedure.

Only qualified personnel should perform maintenance or repairs on the unit.

DO NOT service the unit while standing on wet or icy surfaces, or in wet weather.

---

Observe all other safety precautions described in *"For Your Safety" on page 3*, as well as the respective Nortec EL/Nortec RS operation and maintenance manual.

During cold weather, all maintenance on the unit must be performed in a heated service tent.

The maintenance items discussed in this section are **in addition** to those listed in the Nortec EL/Nortec RS operation and maintenance manual. Refer to the respective Nortec EL/Nortec RS operation and maintenance manual for other maintenance requirements.

---

**IMPORTANT!** Damage caused by use of non-approved parts is not covered by warranty. Use only original Nortec replacement parts.

---

### 7.3.2 Heater and Fan

- Use a vacuum cleaner or compressed air to remove all dirt and pollen from the heater and fan. Make sure that the fan spins freely.
- Clean/replace the filter in the exhaust fan. Refer to *"Spare Parts List" on page 47*.
- Clean/replace the filter in the intake shroud.
- Make sure that the air intake and exhaust shrouds are not clogged with animals, nesting materials or other foreign matter.

### 7.3.3 Freeze Protection System

---

**IMPORTANT!** In cold climates the external freeze protection system (refer to *"External Freeze Protection System" on page 35*) must be properly maintained and fully functional at all times. All water supply and drain lines must be trace heated and properly insulated. The warranty does not cover damage to the humidifier due to freezing.

---

- Make sure that the drain hose connected to the mechanical freeze protection valve inside the unit is not blocked or kinked.
- Make sure that the external freeze protection valves (normally-open and normally-closed valves, or 3-way normally-closed valve inside the building), if installed, are properly maintained and fully functional at all times.

- Make sure the bi-metal strip around the water supply line is securely in place and working properly.
- Inspect the water supply line and all drain lines to make sure the insulation around the piping is undamaged. Make sure the trace heating is working.
- Inspect all external freeze protection system wiring for damage or loose connections.

### 7.3.4 Steam Cylinder

- Replace the steam cylinder on the EL-OC unit, and service the steam cylinder on the RS-OC unit when the service reminder appears on the touchscreen display. Refer to the respective Nortec EL/Nortec RS operation and maintenance manual for replacement procedure.

### 7.3.5 Cleaning

In addition to cleaning the heater, fans and shrouds, use a vacuum cleaner or compressed air to remove all dust and pollen from inside the control cabinet and plumbing cabinet in the unit.

### 7.3.6 Scale Management (RS-OC Units only)

- Depending on the water supply quality, empty the scale collection tank(s) in the RS-OC unit periodically – at the very minimum, twice every year/season.
- Every third time the scale collection tank is cleaned, disassemble and clean the steam cylinder and heating elements. Refer to the Nortec RS operation and maintenance manual.

**Note:** The procedure for removing the steam cylinder is the same as on the indoor units, except for the following – open the drain outlet located at the rear of the scale collection tank (as opposed to the side) and drain the tank. Then disconnect the freeze protection drain hose connection (refer to [Figure 19](#)) and remove the tank. The steam cylinder can now be removed for cleaning.

---

**IMPORTANT!** Make sure that the freeze protection drain hose is reconnected after installing the scale collection tank, and the spigot on the tank is in the Open position.

---

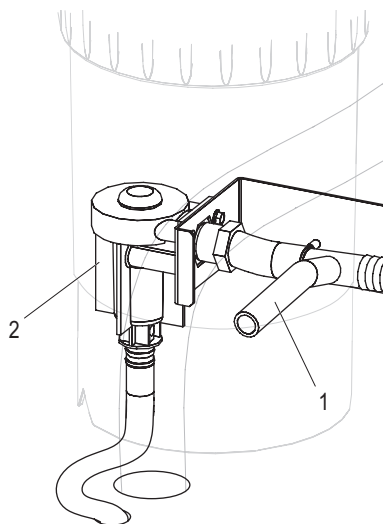

*Figure 19: Drain Hose Connection – RS-OC with Scale Tank*

- 1 Freeze protection drain hose
- 2 Freeze protection valve

### 7.3.7 Restarting After a Freeze-up

In the event of a freeze-up, inspect then restart the unit as follows:

1. Inspect all hoses, fittings, valves and seals for cracks or damage. Contact your Nortec representative to order replacement parts. Check all connections after replacing damaged parts.
2. Make sure that the external freeze protection system (refer to "[External Freeze Protection System](#)" on [page 35](#)) is properly installed and fully functional.
3. Inspect the water supply line and all drain lines and make sure that the trace heating is working and the insulation around the piping is undamaged.
4. Make sure the bi-metal strip around the water supply line is securely in place and working properly.
5. Inspect all external freeze protection system wiring.
6. Make sure that the condensate lines and traps are not ruptured. Prime the condensate traps.
7. Power up the humidifier. The heater will automatically turn on and begin to warm up the humidifier enclosure. Once the temperature inside the enclosure has risen to the appropriate level, the unit will automatically resume normal operation.

## 8 Spare Parts List

---

The spare parts for the Nortec EL/RS Outdoor humidifier is listed in this section. Refer to [Figure 20 on page 48](#).

For all other spare parts refer to the respective Nortec EL/RS Spare Parts List.

# Nortec EL/RS Outdoor Humidifier

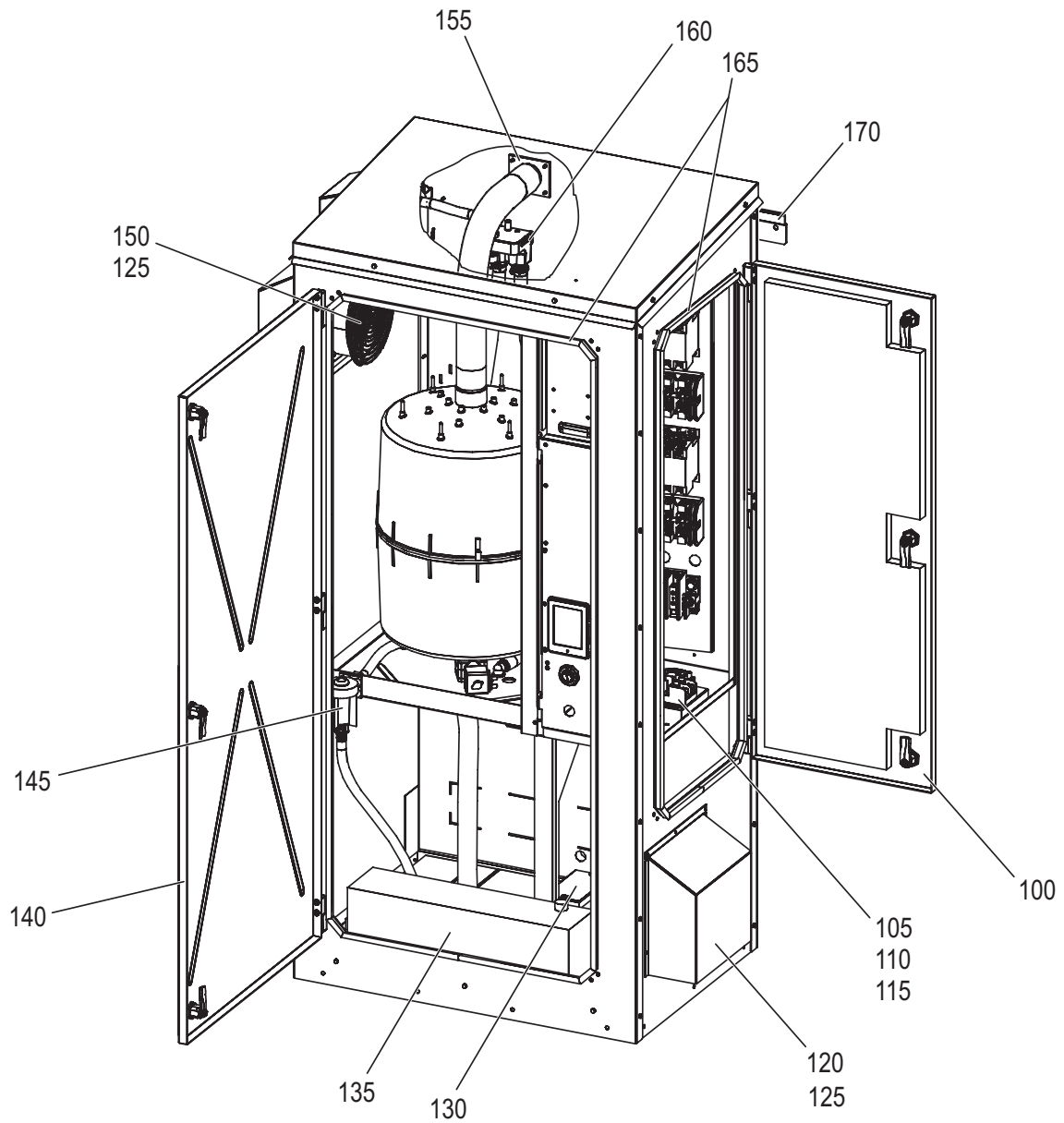

Figure 20: Nortec EL/RS Outdoor Humidifier

## Parts List – Nortec EL/RS Outdoor Humidifier

Item No.	Item Description	Details	Quantity	Nortec Part Number
100	SP, EL RS OC, Door, Cabinet, Controls Kits consist of: Door assembly, insulation, latches, hinges and mounting hardware	Small	1	2585120
	SP, EL RS OC, Door, Cabinet, Controls	Medium/Large	1	2585121
105	SP, EL RS OC, Thermostat (refer to <a href="#">Figure 22 on page 52</a> for details) Kit consists of: Thermostat, STC-100 (qty. 1) Screw (qty. 2)	All	1	2585107
110	SP, EL RS OC, Block, Fuse (refer to <a href="#">Figure 22 on page 52</a> for details) Kit consists of: Block, fuse, 2-pole HCTR (qty. 1) Screw (qty. 2)	All	1	2585114
115	SP, EL RS OC, Fuse (only), 2.5 A (refer to <a href="#">Figure 22 on page 52</a> for details) Kit consists of: Fuse (qty. 2)	See <a href="#">Table 8 on page 51</a>	1	2590290
	SP, EL RS OC, Fuse (only), 3.2 A	See <a href="#">Table 8 on page 51</a>	1	2590291
	SP, EL RS OC, Fuse (only), 3.5 A	See <a href="#">Table 8 on page 51</a>	1	2590292
	SP, EL RS OC, Fuse (only), 4 A	See <a href="#">Table 8 on page 51</a>	1	2590293
	SP, EL RS OC, Fuse (only), 5 A	See <a href="#">Table 8 on page 51</a>	1	2590294
	SP, EL RS OC, Fuse (only), 6 A	See <a href="#">Table 8 on page 51</a>	1	2590295
	SP, EL RS OC, Fuse (only), 7.5 A	See <a href="#">Table 8 on page 51</a>	1	2590296
	SP, EL RS OC, Fuse (only), 8 A	See <a href="#">Table 8 on page 51</a>	1	2590297
120	SP, EL RS OC, Filter, Intake (refer to <a href="#">Figure 22 on page 52</a> for details) Kit consists of: Filter, IP54, 172 mm (qty. 1) Screw (qty. 8) Washer, Lock (qty. 8)	All	1	2585103
125	SP, EL RS OC, Filter (media only) (qty. 5) (refer to <a href="#">Figure 22 on page 52</a> for details)	All	1	2585104
130	SP, EL RS OC, Transformer, 240 V-120 V, 500 VA (refer to <a href="#">Figure 22 on page 52</a> for details) Kits consist of: Transformer, enclosed (qty. 1) Screw (qty. 4) Grommet (qty. 2)	Small/Medium	1	2586081
	SP, EL RS OC, Transformer, 240 V-120 V, 1000 VA	Large	1	2586082
	SP, EL RS OC, Transformer, 600/480 V-120 V, 500 VA	Small/Medium	1	2586083
	SP, EL RS OC, Transformer, 600/480 V-120 V, 1000 VA	Large	1	2586084
	SP, EL RS OC, Transformer, 380 V-120 V, 500 VA	Small/Medium	1	2586472
	SP, EL RS OC, Transformer, 380 V-120 V, 1000 VA	Large	1	2586473
	SP, EL RS OC, Transformer, 208 V-120 V, 500 VA	Small/Medium	1	2586474
	SP, EL RS OC, Transformer, 208 V-120 V, 1000 VA	Large	1	2586475
	SP, EL RS OC, Transformer, 277 V-120 V, 500 VA	Small/Medium	1	2586476
135	SP, EL RS OC, Heater (refer to <a href="#">Figure 22 on page 52</a> for details) Kit consists of: Heater, 500 W (qty. 1) Screw (qty. 2) Connector, Pigtail, 22-14 AWG (qty. 2)	All	1	2585105
140	SP, EL RS OC, Door, Cabinet, Plumbing (qty. 1) Kits consist of: Door assembly, insulation, latches, hinges and mounting hardware	Small	1	2585117
	SP, EL RS OC, Door, Cabinet, Plumbing (qty. 1)	Medium	1	2585118
	SP, EL RS OC, Door, Cabinet, Plumbing (qty. 2)	Large	1	2585119

Note: Refer to [Table 1 on page 10](#) for details of the humidifier sizes.

## Nortec EL/RS Outdoor Humidifier

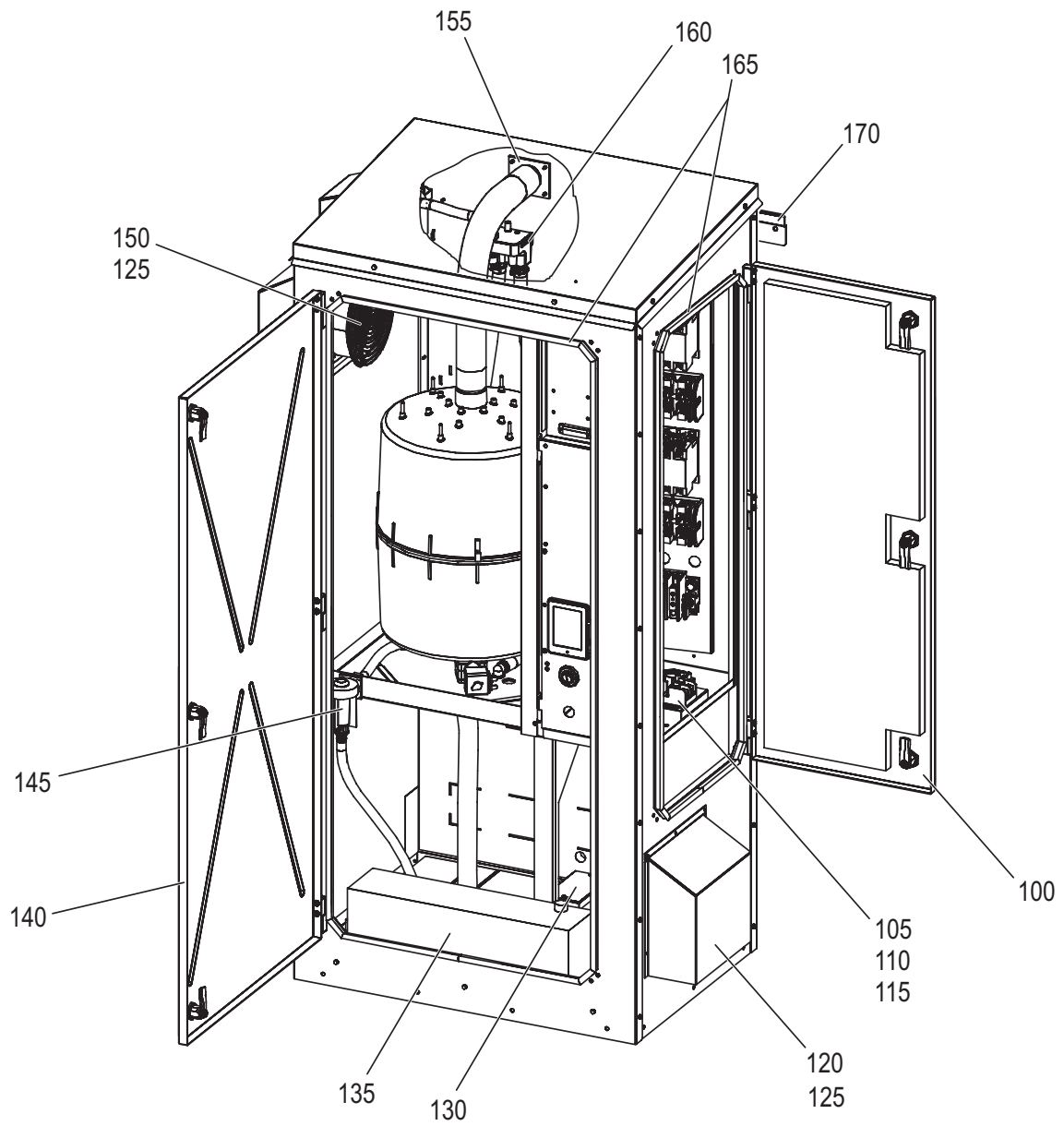

Figure 21: Figure 20: Nortec EL/RS Outdoor Humidifier, continued...

## Parts List (continued...) – Nortec EL/RS Outdoor Humidifier

Item No.	Item Description	Details	Quantity	Nortec Part Number
145	SP, EL RS OC, Freeze Protection (refer to <a href="#">Figure 22 on page 52</a> for details) Kit consists of: Valve, freeze protection, FP-45 (qty. 1) Adaptor, hose barb, 1/2 NPTF × 1/2 in (qty. 1) Hose, 7/6 in (11.5 mm) I.D. × 26 in (670 mm) Clamp, spring (qty. 2) (mounting hardware included)	All	1	2585106
150	SP, EL RS OC, Fan, Exhaust (refer to <a href="#">Figure 23 on page 53</a> for details) Kit consists of: Fan, 180 CFM (5 m <sup>3</sup> /min), IP54, 120 V (qty. 1) Filter, IP54, 172 mm (qty. 1) Screw (qty. 8) Washer, Lock (qty. 8)		1	2585102
155	SP, EL OC, Gasket, Steam Outlet, 7/8 in (22 mm) (refer to <a href="#">Figure 23 on page 53</a> for details) Kits consist of: Gasket (qty. 2)	Small	1	2585122
	SP, EL RS OC, Gasket, Steam Outlet, 1-3/4 in (45 mm)	Medium/Large	1	2585123
160	SP, RS OC, Fill Cup (refer to <a href="#">Figure 23 on page 53</a> for details) Kits consist of: Assembly, fill cup (qty. 1) – includes fill cup, hoses, gaskets, fitting, spring clamps	Medium/Large	1	2585108
	SP, EL OC, Fill Cup (refer to <a href="#">Figure 23 on page 53</a> for details)	Small	1	2585109
	SP, EL OC, Fill Cup	Medium/Large	1	2585110
165	SP, EL RS OC, Gasket, Door Kit consists of: Seal, rubber, trim, push-on-edge, bulk (qty. 8 ft (2.4 m)) Seal, rubber, trim, push-on-edge, bulk (qty. 7 ft (2.1 m))	Small	1	2585111
	SP, EL RS OC, Gasket, Door Kit consists of: Seal, rubber, trim, push-on-edge, bulk (qty. 11 ft (3.4 m)) Seal, rubber, trim, push-on-edge, bulk (qty. 7.75 ft (2.4 m))	Medium	1	2585112
	SP, EL RS OC, Gasket, Door Kit consists of: Seal, rubber, trim, push-on-edge, bulk (qty. 11.5 ft (3.5 m)) Seal, rubber, trim, push-on-edge, bulk (qty. 11 ft (3.4 m)) Seal, rubber, trim, push-on-edge, bulk (qty. 7.75 ft (2.4 m))	Large	1	2585113
170	SP, EL OC, Bracket, Mounting (mounting hardware not included)	Small	1	2585124
	SP, EL RS OC, Bracket, Mounting (mounting hardware not included)	Medium	1	2585125
	SP, EL RS OC, Bracket, Mounting (mounting hardware not included)	Large	1	2585126

Note: Refer to [Table 1 on page 10](#) for details of the humidifier sizes.

**Table 8: Item number 115, SP, EL RS OC, Fuse (only)**

Fuse part #'s 2 fuses required per unit	Supply voltage					
	208 Vac	240 Vac	277 Vac	380 Vac	480 Vac	600 Vac
<b>Small/Medium units (0.5 kVA transformer)</b>	2590293 (4 A)	2590292 (3.5 A)	2590295 (6 A)	2590293 (4 A)	2590291 (3.2 A)	2590290 (2.5 A)
<b>Large units (1.0 kVA transformer)</b>	2590297 (8 A)	2590296 (7.5 A)	2590295 (6 A)	2590294 (5 A)	2590292 (3.5 A)	2590294 (5 A)

# Nortec EL/RS Outdoor Humidifier

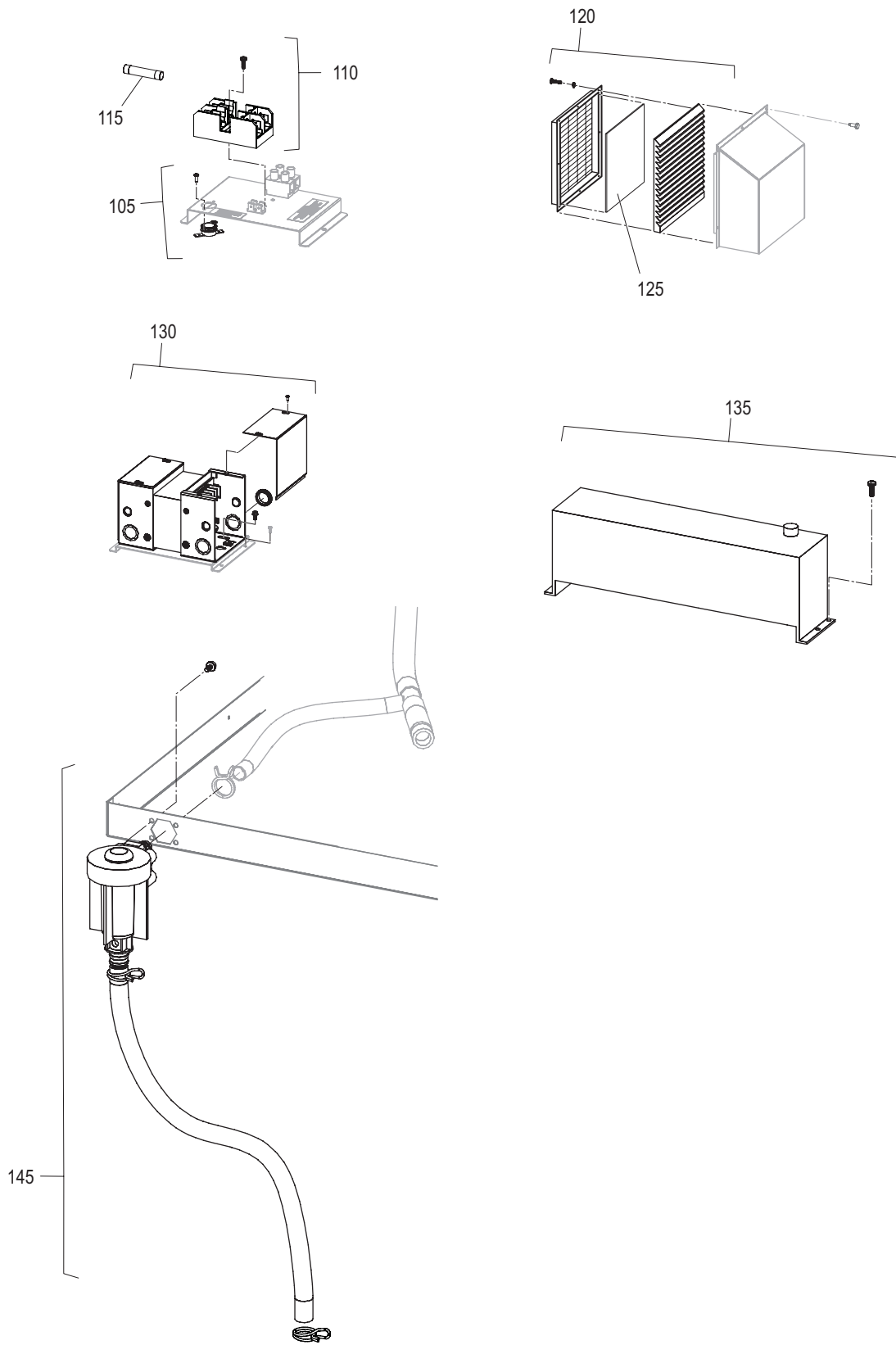

Figure 22: Nortec EL/RS Outdoor Humidifier – Kit Details

Note: Greyed out items are not a part of the kits.

# Nortec EL/RS Outdoor Humidifier

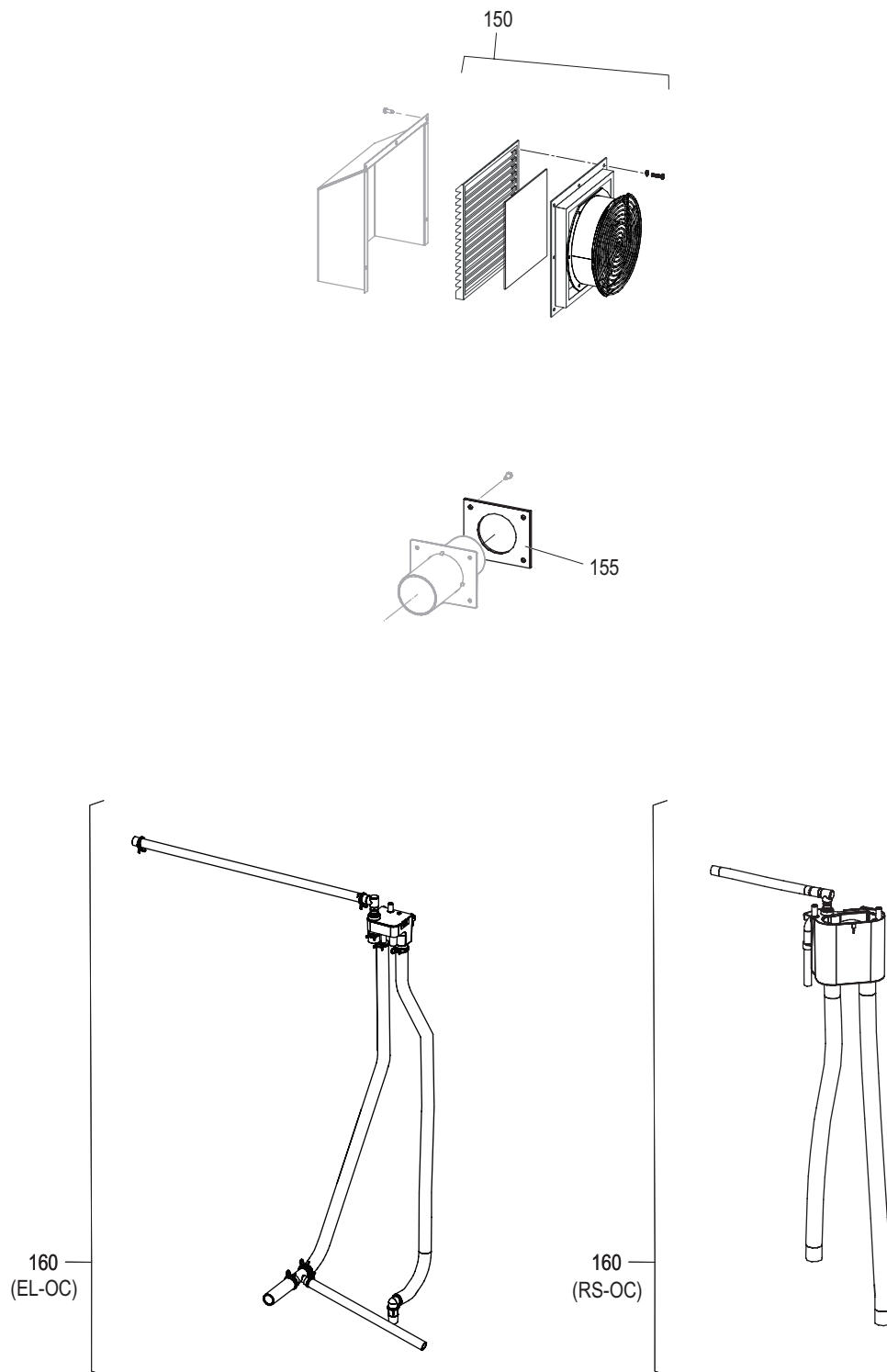

Figure 23: Nortec EL/RS Outdoor Humidifier – Kit Details, continued...

Note: Greyed out items are not a part of the kits.

This page intentionally left blank

# 9 Decommissioning

## 9.1 General

If the Nortec EL/RS Outdoor humidifier needs to be removed from service (for disposal or long-term storage), strictly follow all instructions in this chapter.

### Personnel Qualifications

Decommissioning of the Nortec EL/RS Outdoor humidifier must only be performed by a qualified service technician authorized by the customer. It is the customer's responsibility to verify qualifications of the personnel.

### Safety

Decommissioning of the Nortec EL/RS Outdoor humidifier will require personnel to access the inside of the control and plumbing cabinets in the humidifier, which may expose personnel and equipment to safety hazards.

Observe all other safety precautions described in *"For Your Safety" on page 3*, as well as the respective Nortec EL/Nortec RS operation and maintenance manual.

## 9.2 Removal from Service for Disposal or Long-term Storage

Remove the Nortec EL/RS Outdoor humidifier from service (for disposal or long-term storage) as follows:

1. Drain the steam cylinder (and the scale tank on the RS-OC unit), and shut down the humidifier – refer to the respective Nortec EL/Nortec RS operation and maintenance manual. Follow all safety precautions.
2. Disconnect and remove the power supply to the Nortec EL/RS Outdoor humidifier. Refer to *"Outdoor Enclosure Wiring Diagram" on page 40*, and the wiring diagrams in the Nortec EL/Nortec RS manuals.
3. Disconnect and remove the control signal inputs from the humidifier.
4. Disconnect the steam and condensate lines, and empty out all fluids.
5. Disconnect the water and drain connections to the humidifier.



### WARNING!

**Heavy object – risk of personal injury and damage to equipment!**

**Prevention:** Use a forklift or crane to lift the humidifier, and protect the unit from damage by tethers and other lifting equipment.

6. Carefully remove the humidifier from its mounting surface.
7. Cap the pipe chases.
8. If the Nortec EL/RS Outdoor humidifier is to be put into long-term storage, store the humidifier in its original packaging inside a protected area that meets the following requirements:
  - Room temperature: 41 to 104 °F (5 to 40 °C)
  - Room humidity: 10 to 75% RH
9. If the Nortec EL/RS Outdoor humidifier is to be disposed off, refer to *"Disposal/Recycling" on page 56*.

### **9.3 Disposal/Recycling**

The Nortec EL/RS Outdoor humidifier should not be disposed off in domestic waste, and should only be disposed off in accordance with local regulations at authorized collection facilities.

If you have any questions, contact the appropriate local authorities or your local Nortec representative.

# 10 Product Specifications

## 10.1 Performance Data

Refer to the respective Nortec EL/RS Operation and Maintenance manual for the performance data.

## 10.2 Operating Data

The following data pertains to the Nortec EL/RS Outdoor humidifier. Refer to the respective Nortec EL/RS Operation and Maintenance manual for additional operating data.

Ambient Conditions	
Ambient temperature	-40 °F to 104 °F (-40 °C to +40 °C)

## 10.3 Weights

Table 9: Nortec EL/RS Outdoor Humidifier Weights

Housing Size	Nortec Model	Weight lb (kg)	
		Net	Operating
Small	EL-OC 005-010	123 (56)	132 (60)
	EL-OC 020	123 (56)	143 (65)
	EL-OC 030	123 (56)	159 (72)
Medium	EL-OC 050-100	172 (78)	236 (107)
	RS-OC 010-020	220 (100)	249 (113)
	RS-OC 030-090	220 (100)	278 (126)
Large	EL-OC 150/200*	256 (116)	381 (173)
	RS-OC 090-180*	346 (157)	459 (208)

\* Units with two steam cylinders

## 10.4 Dimensions

All dimensions are in inches, and values in brackets are in millimeters. Drawings not to scale.

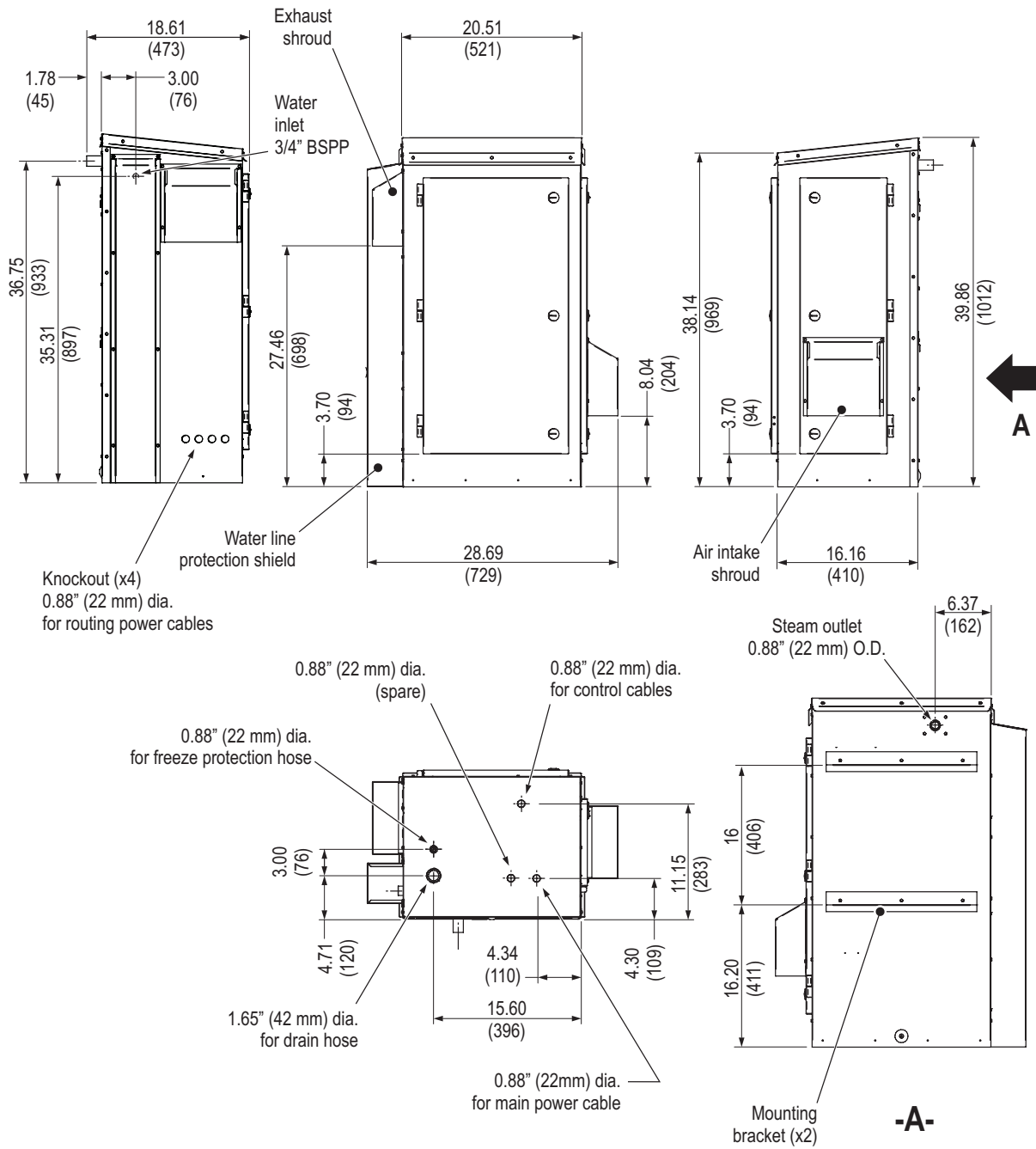

Figure 24: Nortec EL/RS Outdoor Steam Humidifier, Small Housing\*

\* EL-OC 005-030

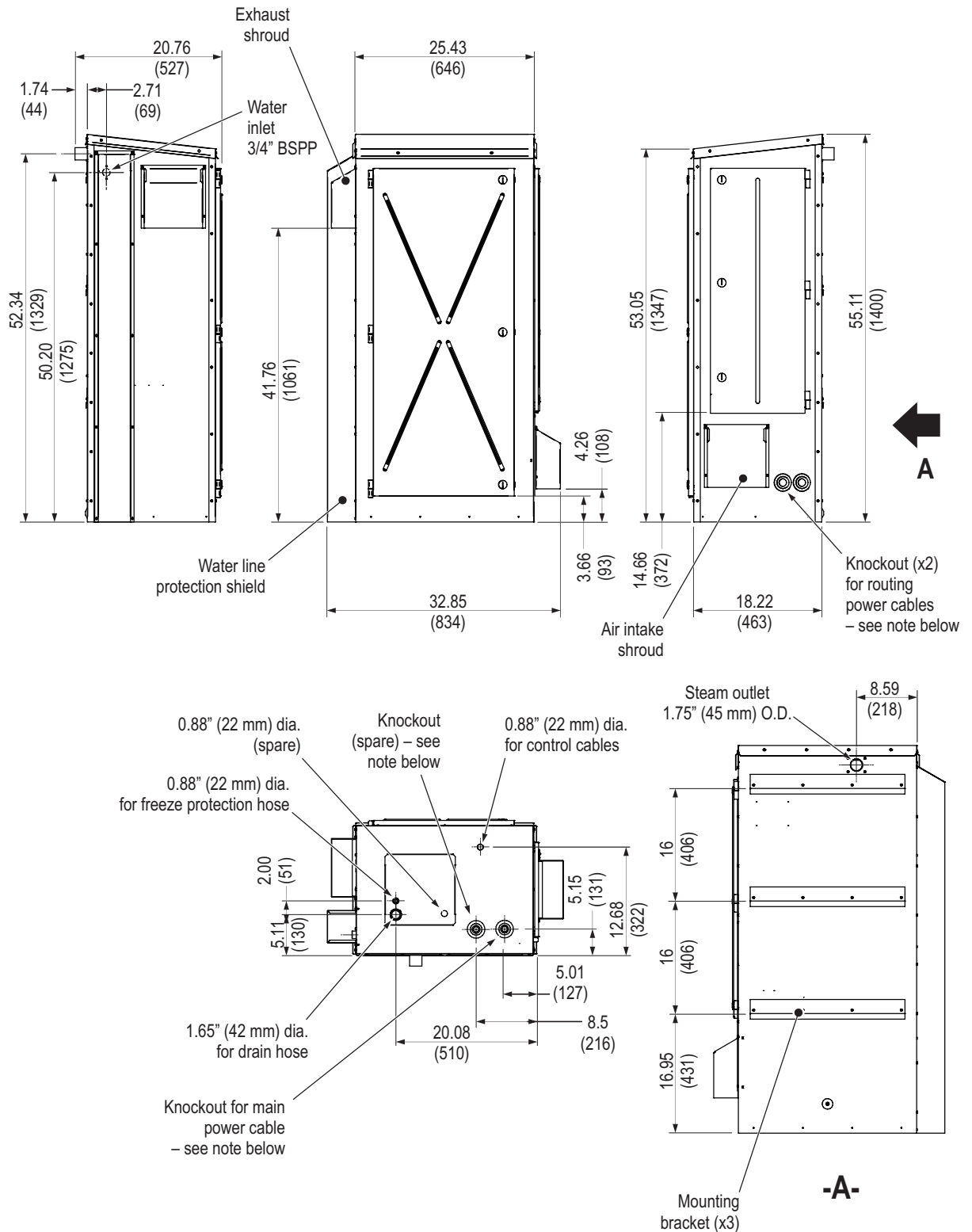

Figure 25: Nortec EL/RS Outdoor Steam Humidifier, Medium Housing\*

\* EL-OC 050-100 and RS-OC 010-090. For RS-OC 090 with two cylinders, refer to [Figure 26 on page 60](#).

**Note:** The main power and auxiliary power cables enter the unit through multi-diameter knockouts with the following hole sizes: 7/8 in (22 mm), 1-1/8 in (29 mm), 1-3/4 in (45 mm) and 2.5 in (64 mm).



# A Appendix

## A.1 Weather Data

The following weather design data is provided to assist in determining suitable locations for rooftop mounting of the Nortec EL/RS Outdoor units. Locations that experience very cold winter conditions are not good candidates for rooftop mounting of the Nortec EL/RS Outdoor units. Installing the humidifier in areas where temperature drops below -40 °F (-40 °C) during January, or rises above 104 °F (40 °C) during July (see [Table A1](#) below) is not recommended. These harsh climates can make performing maintenance difficult, and increase the risk of the humidifier freezing or overheating.

To determine the prevailing wind speeds for the selected location, refer to <http://windspeed.atcouncil.org/>.

*Table A1: Weather Data by Location (Source: ASHRAE, except as noted)*

Location		January Temperature		January Relative Humidity (% RH)			July Temperature		July Relative Humidity (% RH)		
State/Province	City	Dry Bulb °F	Dry Bulb °C	7:30 A.M.	1:30 P.M.	7:30 P.M.	Dry Bulb °F	Dry Bulb °C	7:30 A.M.	1:30 P.M.	7:30 P.M.
Alabama	Birmingham	10	-12	81	61	66	95	35	84	56	68
	Mobile	10	-12	–	–	–	95	35	90	64	78
Arizona	Flagstaff	-10	-23	83	58	–	90	32	77	36	–
	Phoenix	25	-4	75	47	39	105	41	53	31	23
	Yuma	30	-1	56	37	27	110	44	51	31	23
Arkansas	Little Rock	5	-15	80	67	68	95	35	85	55	59
California	Eureka	30	-1	87	–	77	90	32	92	–	80
	Fresno	25	-4	93	80	66	105	41	61	36	20
	Los Angeles	35	2	63	46	51	90	32	85	50	54
	Sacramento	30	-1	90	82	70	100	38	76	46	28
	San Diego	35	2	76	58	60	85	29	86	68	65
	San Francisco	35	2	84	68	70	85	29	92	75	78
Colorado	Denver	-10	-23	54	37	41	95	35	55	27	30
	Grand Junction	-15	-26	77	64	64	95	35	48	27	22
	Pueblo	-20	-29	67	44	48	95	35	73	34	35
Connecticut	New haven	0	-18	75	65	69	95	35	77	64	74
Deleware	Wilmington	0	-18	77	62	70	95	35	80	52	69
District of Columbia	Washington	0	-18	73	56	64	95	35	78	52	64
Florida	Jacksonville	25	-4	89	56	75	95	35	85	57	76
	Miami	35	2	87	59	75	91	33	83	64	76
Georgia	Atlanta	10	-12	80	64	69	95	35	83	57	68
	Augusta	10	-12	84	59	69	98	37	83	55	69
	Savannah	20	-7	83	58	72	95	35	85	61	80
Idaho	Boise	-10	-23	82	75	74	95	35	54	34	23
	Lewiston	-5	-20	79	73	71	95	35	64	37	25
Illinois	Cairo	0	-18	81	69	–	98	37	83	57	–
	Chicago	-10	-23	81	70	75	95	35	78	51	55
	Peoria	-10	-23	83	72	77	96	35	81	53	58
Indiana	Fort Wayne	-10	-23	84	75	81	95	35	84	53	58
	Indianapolis	-10	-23	83	72	78	95	35	84	54	60
	Terre Haute	0	-18	82	70	76	95	35	77	50	56
Iowa	Davenport	-15	-26	–	–	–	95	35	–	–	–
	Sioux City	-20	-29	78	67	72	95	35	86	55	54

Location		January Temperature		January Relative Humidity (% RH)			July Temperature		July Relative Humidity (% RH)		
State/Province	City	Dry Bulb °F	Dry Bulb °C	7:30 A.M.	1:30 P.M.	7:30 P.M.	Dry Bulb °F	Dry Bulb °C	7:30 A.M.	1:30 P.M.	7:30 P.M.
Kansas	Dodge City	-10	-23	78	57	61	95	35	77	45	52
	Topeka	-10	-23	78	64	67	100	38	85	54	54
Kentucky	Louisville	0	-18	78	68	69	95	35	77	52	57
Louisiana	New Orleans	20	-7	85	67	73	95	35	84	64	72
	Shreveport	20	-7	83	67	66	100	38	86	56	62
Maine	Portland	-5	-21	81	65	74	90	32	78	58	76
Maryland	Baltimore	0	-18	72	68	56	95	35	71	52	65
Massachusetts	Boston	0	-18	72	59	67	92	33	72	55	70
Michigan	Detroit	-10	-23	82	71	77	95	35	74	50	56
	Grande Rapids	-10	-23	85	78	80	95	35	76	51	54
Minnesota	Duluth	-25	-32	78	74	74	93	33	87	61	66
	Minneapolis	-20	-29	82	72	75	95	35	82	54	54
Mississippi	Vicksburg	10	-12	82	65	67	95	35	87	61	70
Missouri	Kansas City	-10	-23	78	64	66	100	38	76	48	47
	St. Louis	0	-10	77	65	68	95	35	73	50	55
Montana	Billings	-25	-32	67	73	60	90	32	65	40	33
	Butte	-20	-29	76	70	71	95	35	82	36	33
Nebraska	North Platte	-20	-29	80	62	66	85	29	84	50	46
	Omaha	-10	-23	82	68	73	95	35	80	51	51
Nevada	Reno	-5	-21	82	67	54	95	35	72	25	20
New Hampshire	Concord	-15	-26	78	60	69	90	32	80	49	69
New Jersey	Atlantic City	5	-15	79	68	74	95	35	81	72	82
	Newark	0	-18	72	79	65	95	35	75	51	65
	Trenton	0	-18	73	62	68	95	35	77	55	68
New Mexico	Albuquerque	0	-18	68	51	46	95	35	59	33	28
New York	Albany	-10	-23	75	63	71	93	34	79	52	64
	Buffalo	-5	-21	79	72	78	93	34	78	53	63
	New York	0	-18	72	61	66	95	35	75	58	68
	Rochester	-5	-21	81	73	79	95	35	80	50	60
North Carolina	Asheville	0	-18	82	59	69	93	34	88	56	73
	Raleigh	10	-12	82	57	69	95	35	86	55	72
North Dakota	Bismarck	-30	-34	77	71	75	95	35	85	52	49
Ohio	Cincinnati	0	-18	82	70	74	95	35	84	52	60
	Cleveland	0	-18	81	72	79	95	35	79	52	58
	Columbus	-10	-23	83	71	76	95	35	78	52	60
	Toledo	-10	-23	79	72	75	95	35	76	52	59
Oklahoma	Oklahoma City	0	-18	79	62	65	101	38	80	49	51
Oregon	Baker	-5	-21	83	81	78	90	32	69	68	36
	Portland	10	12	87	82	78	90	32	86	63	48
Pennsylvania	Harrisburg	0	-18	72	49	65	95	35	78	51	62
	Philadelphia	0	-18	74	65	68	95	35	78	52	64
	Pittsburg	0	-18	77	67	63	95	35	80	52	63
	Scranton	-5	-21	80	67	-	95	35	77	50	-
Rhode Island	Providence	0	-18	73	60	67	93	34	79	57	73
South Carolina	Charleston	15	-9	87	55	76	95	35	88	64	82
	Columbia	10	-12	81	57	65	95	35	83	56	68
South Dakota	Huron	-20	-29	79	72	76	95	35	86	52	49
	Rapid City	-20	-29	71	69	67	95	35	71	42	40
Tennessee	Knoxville	0	-18	83	65	69	95	35	83	55	66
	Memphis	0	-18	82	67	73	95	35	85	55	59

Location		January Temperature		January Relative Humidity (% RH)			July Temperature		July Relative Humidity (% RH)		
State/Province	City	Dry Bulb °F	Dry Bulb °C	7:30 A.M.	1:30 P.M.	7:30 P.M.	Dry Bulb °F	Dry Bulb °C	7:30 A.M.	1:30 P.M.	7:30 P.M.
Texas	Amarillo	-10	-23	71	51	52	100	38	77	43	42
	Corpus Christi	20	-7	88	66	75	95	35	93	58	68
	Dallas	10	-12	81	62	62	100	38	79	50	47
	El Paso	10	-12	63	45	39	100	38	60	37	30
	Houston	20	-7	85	66	73	95	35	90	58	66
	San Antonio	20	-7	82	60	59	100	38	88	49	45
Utah	Salt Lake City	-10	-23	80	71	72	95	35	56	27	23
Vermont	Burlington	-10	-23	81	69	78	90	32	76	54	67
Virginia	Richmond	15	-9	84	60	68	95	35	81	57	72
Washington	Seattle	15	-9	86	80	74	85	29	86	63	47
	Walla Walla	-5	-21	80	74	78	95	35	50	33	22
West Virginia	Charleston	0	-18	79	64	70	95	35	88	53	67
	Parkersburg	-10	-23	82	66	74	95	35	80	52	65
Wisconsin	Green Bay	-15	-26	75	68	73	95	35	85	58	64
	Milwaukee	-15	-26	76	70	73	95	35	81	58	64
Wyoming	Cheyenne	-15	-26	59	48	55	95	35	73	36	40
Alberta	Calgary	-29	-34		71		87	31		34	
	Edmonton	-29	-34		75		86	30		42	
	Grande Prairie	-43	-42		80		84	29		38	
	Lethbridge	-32	-36		66		91	33		30	
	Medicine Hat	-30	-34		73		96	36		31	
British Columbia	Estevan point	17	-8		84		87	31		32	
	Fort Nelson	-40	-40		79		94	34		32	
	Penticton	0	-18		81		85	29		44	
	Prince George	-37	-38		82		73	23		53	
	Prince Rupert	11	-12		87		80	27		54	
	Vancouver	15	-9		87		80	27		41	
Manitoba	Brandon	-29	-34		73		90	32		50	
	Churchill	-40	-40		76		79	26		57	
	The Pas	-35	-37		77		85	29		54	
	Winnipeg	-29	-34		78		90	32		50	
New Brunswick	Campbellton	-18	-28		77		87	31		54	
	Fredricton	-16	-27		72		89	32		47	
	Moncton	-12	-24		82		88	31		52	
	Saint John's	-12	-24		82		81	27		62	
Newfoundland	Corner Brook	-10	-23		84		84	29		47	
	Gander	-5	-21		76		85	29		45	
	Goose Bay	-26	-32		85		86	30		42	
	St. John's	1	-17				79	26		60	
North-West Territories	Frobisher	-45	-43		77		63	17		67	
	Resolute	-49	-45		71		54	12		81	
	Yellowknife	-49	-45		82		78	26		50	
Nova Scotia	Halifax	0	-18		83		83	28		50	
	Sydney	1	-17		84		84	29		56	
	Yarmouth	5	-15		83		76	24		70	
Nunavut	Iqaluit (Source: Internet)	-38	-39		56		64	18		95	

Location		January Temperature		January Relative Humidity (% RH)			July Temperature		July Relative Humidity (% RH)		
State/Province	City	Dry Bulb °F	Dry Bulb °C	7:30 A.M.	1:30 P.M.	7:30 P.M.	Dry Bulb °F	Dry Bulb °C	7:30 A.M.	1:30 P.M.	7:30 P.M.
Ontario	Hamilton	0	-18	75			91	33	52		
	Kapuskasing	-30	-34	79			87	31	52		
	Kingston	-11	-24				85	29	69		
	Kitchener	-3	-19	84			88	31	58		
	London	0	-18	80			90	32	53		
	North Bay	-20	-29	77			87	31	46		
	Ottawa	-17	-27				90	32	50		
	Peterborough	-13	-25	77			90	32	53		
	Sault Ste. Marie	-20	-29				88	29	48		
	Sioux Lookout	-33	-36	78			65	18	69		
	Sudbury	-20	-29	81			89	32	44		
	Thunder Bay	-27	-33	80			86	30	52		
	Timmins	-33	-36	79			90	32	45		
	Toronto	-3	-19	82			90	32	56		
Windsor	-3	-16				92	31	51			
Prince Edward Island	Charlottetown	-6	-21	86			84	29	57		
Quebec	Knob Lake	-40	-40	79			55	13	70		
	Mont Joli	-11	-24	75			62	17	71		
	Montreal	-16	-27				88	31	58		
	Port Harrison	-39	-39	76							
	Quebec City	-19	-28	81			86	30	60		
	Sept-Iles	-27	-33				80	27	47		
	Sherbrooke	-18	-28				87	31	58		
Trois Rivieres	-18	-28				88	31	58			
Saskatchewan	Prince Albert	-41	-41	77			88	31			
	Regina	-34	-37	81			92	33			
	Saskatoon	-34	-37	76			90	32			
	Swift Current	-29	-34	79			93	34			
Yukon Territory	Dawson	-56	-49	76			57	14	60		
	Whitehorse	-45	-43	82			78	26	40		

# B Appendix

## B.1 Installation Checklist

The following is a consolidated installation checklist that can be used in the commissioning of the unit:

### Mounting

- Unit mounted in an outdoor environment where it is not exposed to severe weather, or where the temperature drops below -40 °F (-40 °C), and where the wind speed does not exceed 100 mph (160 km/h)?
- Adequate clearances maintained (according to *"Location and Suggested Clearances" on page 22*, and all local and national installation codes)?
- Mounting surface stable and reinforced to support the full operating weight of the humidifier?
- Unit level?
- Unit fastened securely?

### Steam Line

- Total system backpressure does not exceed 5.5 in H<sub>2</sub>O (1.37 kPa)?
- Steam line maintain constant minimum upslope of 10° or downslope of 2°? If steam line runs upward, is a condensate trap installed at the location where the steam exits the unit? Condensate line and trap trace heated?
- Steam line sized correctly, and does not exceed maximums specified in the Nortec EL/RS manuals?
- Minimum bend radius of 12 in (300 mm) for steam hose, or 5× internal diameter for rigid pipes maintained?
- Steam line does not reduce in diameter except at the steam distributor? Condensate line installed just before the restriction?
- Steam lines do not merge except at the steam distributor through a Nortec adaptor?
- Steam line does not sag or kink? Supported adequately? Condensate trap installed at all low points in line?
- If a steam hose is used, is it attached securely with clamps? Clamps secure without crushing steam line?
- Allowances for thermal expansion during operation, and shortening of the hose due to aging taken into consideration?
- Steam line properly insulated?
- Steam line purged?

### Condensate Line

- Drain water temperature meet local code requirements?
- Condensate line from the steam distributor condensate port connected to the humidifier fill cup port, or the drain?
- Condensate lines installed at all low points, and at horizontal -to-vertical transitions in the steam line?
- Condensate lines in the steam line always connect to full-size "T" connectors?
- Condensate traps have a minimum loop height of 8 in (200 mm) and installed at least 12 in (300 mm) below the "T" connector or steam distributor?
- All condensate lines have a constant minimum downslope of 1 in/48 in (1.2°)?
- Maximum distance between the condensate traps on long runs 15 ft (4.5 m)?

- Condensate lines free of kinks?
- Condensate lines purged?
- Condensate traps primed with water?

### **Water Connections**

- Water and drain lines installed to local plumbing codes?
- Shutoff valve and union fitting installed in supply line?
- Water supply piping minimum 1/2 in (13 mm) diameter, and routed through a pipe chase to the unit?
- Optional 5 µm water filter installed in the water supply line (inside the building) close to the humidifier?
- Water supply surge-free and pressure regulated to 30-80 psig (207-550 kPa)?
- Water temperature 34-104°F (1-40°C) for EL-OC unit, and 140°F (60°C) for RS-OC unit?
- Cold potable drinking water only (not RO or DI) for EL-OC unit?
- For EL-OC unit, is conductivity of the water 150-1200 micro-seimens/cm, hardness 0-12 gpg (when Silica is between 0-4 ppm), or 0-3 gpg (when Silica is between 4-14 ppm), and pH 7-7.5?
- For RS-OC unit, is conductivity of the water 1-1500 micro-seimens/cm, hardness 0-12 gpg, Silica 0-12 ppm, pH 6.5-7.5 pH, and chloride 0-50 ppm?
- If the unit is installed in a cold climate, are the freeze protection valves (normally-open and a normally-closed valve, or a 3-way normally-closed valve) installed inside building?
- All drain lines routed through the bottom panel in the unit through a pipe chase to the air gap funnel?
- All gaps around the drain lines sealed where they pass through the bottom panel in the unit?
- Drain lines have a constant minimum downslope of 1 in/48 in (1.2°) to funnel without touching its sides or bottom?
- Drain lines from large humidifiers empty into separate air gap funnels before connecting to the building drain?
- Air gap funnel(s) connected to a dedicated building drain (recommended) with a drainage capacity of at least 2.3 gpm (8.7 L/min) for an EL-OC unit and 6.7 gpm (30 L/min) for a RS-OC unit – per steam cylinder?
- Drain line exiting the funnel minimum 7/8 in (22 mm) in diameter for an EL-OC unit, and minimum 1-3/4 in (45 mm) for a RS-OC unit?
- If the unit is installed in a cold climate, are the water supply and drain lines trace heated and insulated?
- All pipe chases sealed to isolate the unit from pressure inside the building?
- Any leaks?
- Supply and drain lines flushed to remove all debris? Strainer in the fill valve clear of all debris?

### **Electrical Connections**

- Power supply meet the voltage and current requirements shown on the specification label ([Figure 3 on page 9](#))?
- All electrical cables enter the bottom of the unit through minimum IP54-rated cable glands?
- Power supply have a NEMA Type 3R (or greater) weatherproof fused disconnect switch? Fusing rated for maximum circuit protection indicated on the specification label? Disconnect switch installed external to the unit, and NOT directly attached to unit?
- All wiring done according to the wiring diagrams and instructions in this manual?
- Electrical installation meet the applicable national and local codes?

# Warranty

Nortec Humidity Inc. and/or Nortec Humidity Ltd. (hereinafter collectively referred to as THE COMPANY), warrant for a period of two years after installation or 30 months from manufacturer's ship date, whichever date is earlier, that THE COMPANY's manufactured and assembled products, not otherwise expressly warranted (with the exception of the cylinder), are free from defects in material and workmanship. No warranty is made against corrosion, deterioration, or suitability of substituted materials used as a result of compliance with government regulations.

THE COMPANY's obligations and liabilities under this warranty are limited to furnishing replacement parts to the customer, F.O.B. THE COMPANY's factory, provided that the defective part(s) is returned freight prepaid by the customer. The replacement parts are warranted for the balance of the term of the warranty on the original humidifier or 90 days, whichever is longer.

The warranties set forth herein are in lieu of all other warranties expressed or implied by law. No liability whatsoever shall be attached to THE COMPANY until said products have been paid for in full and then said liability shall be limited to the original purchase price for the product. Any further warranty must be in writing, signed by an officer of THE COMPANY.

THE COMPANY's limited warranty on accessories, not manufactured by the COMPANY, such as controls, humidistats, pumps, etc., is limited to the warranty of the original equipment manufacturer from date of original shipment of humidifier.

THE COMPANY makes no warranty and assumes no liability unless the equipment is installed in strict accordance with a copy of the catalog and installation manual in effect at the date of purchase, and by a contractor approved by THE COMPANY to install such equipment.

THE COMPANY makes no warranty and assumes no liability whatsoever for consequential damage or damage resulting directly from misapplication, incorrect sizing or lack of proper maintenance of the equipment.

THE COMPANY makes no warranty and assumes no liability whatsoever for damage to the humidifier, supply lines, drain lines, or steam distribution systems caused by freezing.

THE COMPANY reserves the right to change the design, specifications and performance criteria of its products without notice or obligation.



Consulting, Sales and Service:

**U.S.A.**  
835 Commerce Park drive  
Ogdensburg, NY 1366-2209

**CANADA**  
2740 Fenton Road  
Ottawa, ON, K1T 3T7

Tel: 1.866.667.8321  
Fax: 613.822.7964

Email: [na.info@condair.com](mailto:na.info@condair.com)  
Website: [www.condair.com](http://www.condair.com)

