



# OPERATION AND MAINTENANCE MANUAL

Gas-fired Steam Humidifier  
Condair GS  
Series II



**DANGER!**

**Fire or explosion hazard!**

**If the information in this manual is not followed exactly, a fire or explosion may result causing property damage, personal injury or loss of life.**

**DO NOT store or use gasoline or other flammable vapors and liquids in the vicinity of this or any other appliance.**

#### **WHAT TO DO IF YOU SMELL GAS**

- DO NOT try to light any appliance.
- DO NOT touch any electrical switch.
- DO NOT use any phone in the building.
- Close the gas valve.
- Open windows and doors.
- Immediately call your gas supplier from a neighbor's phone. Follow the gas supplier's instructions.
- If you cannot reach your gas supplier, call the fire department.

# Thank you for choosing Condair

Installation date (DD/MM/YYYY):

Commissioning date (DD/MM/YYYY):

Site:

Model:

Serial number:

## Proprietary Notice

This document and the information disclosed herein are proprietary data of Condair Ltd. Neither this document, nor the information contained herein shall be reproduced, used, or disclosed to others without the written authorization of Condair Ltd., except to the extent required for installation, operation or maintenance of the customer's equipment.

## Liability Notice

Condair Ltd. does not accept any liability due to incorrect installation, maintenance or operation of the equipment, or due to the use of parts/components/equipment that are not authorized by Condair Ltd.

## Copyright Notice

© Condair Ltd., All rights reserved.

Technical modifications reserved

# Contents

---

<b>1</b>	<b>Introduction</b>	<b>6</b>
1.1	Notes on this manual	6
<b>2</b>	<b>For Your Safety</b>	<b>8</b>
<b>3</b>	<b>Product Overview</b>	<b>12</b>
3.1	General Description	12
3.2	Functional Description	15
<b>4</b>	<b>Operator Interface</b>	<b>18</b>
4.1	Controls	18
4.2	Control Software	19
4.2.1	Home Screen	19
4.2.2	Operating Status	20
4.2.3	Maintenance and Fault Status	21
4.2.4	Help	21
4.2.5	System Information	22
4.2.6	Main Menu	27
4.2.6.1	Configuration Menu	28
4.2.6.2	Service Menu	42
4.2.6.3	Setpoint	44
4.2.6.4	Administrator Menu	45
4.3	Software Configuration	47
4.3.1	Configuring the Control Software	47
4.3.2	Configuring for Multi-Unit Operation	48
<b>5</b>	<b>Operation</b>	<b>49</b>
5.1	General	49
5.2	Operating Procedures	49
5.2.1	Filling the System	49
5.2.2	Ignition Safety Shutoff Test	49
5.2.3	Starting the Humidifier	50
5.2.4	Remote Monitoring	51
5.2.5	Inspections During Operation	51
5.2.6	Manually Initiate Tank Draining	52
5.2.7	Full Tank Blowdown	53
5.2.8	Shutting Down	53
5.2.9	Restarting After Shutdown	54

<b>6</b>	<b>Maintenance</b>	<b>55</b>
6.1	General	55
6.2	Mandatory Maintenance Schedule	56
6.3	List of Consumables	57
6.4	Management of Scale and Chloride Levels	58
6.4.1	Adjusting Blowdown Settings	59
6.5	Maintenance Procedures	60
6.5.1	Removal and Installation of Access Panels	60
6.5.2	Cleaning the Tank	62
6.5.3	Cleaning the Secondary Heat-exchanger	63
6.5.4	Cleaning the Float Chamber	64
6.5.5	Cleaning Hoses, Dual Fill Valves and Drain Pump	65
6.5.6	Cleaning the Burner Assembly	67
6.5.7	Replacing Backup Battery	68
6.5.8	Replacing Internal Fuse	69
6.5.9	Resetting Service Reminder	69
6.5.10	Installing Software Updates	69
<b>7</b>	<b>Fault Isolation</b>	<b>70</b>
7.1	General	70
7.2	Fault Indication	70
7.3	General Troubleshooting	70
7.4	Warning and Fault List	72
7.5	Resetting Fault Status	78
<b>8</b>	<b>Decommissioning</b>	<b>79</b>
8.1	General	79
8.2	Removal from Service for Disposal or Long-term Storage	79
8.3	Disposal/Recycling	79
<b>9</b>	<b>Performance and Operating Data</b>	<b>80</b>
9.1	Performance Data	80
9.2	Operating Data for GS Series II Indoor Models	80

# 1 Introduction

Thank you for purchasing the Condair GS steam humidifier.

The Condair GS steam humidifier incorporates the latest technical advances and meets all recognized safety standards. Improper use of the Condair GS humidifier may result in danger to the user or third parties, and/or damage to property.

To ensure a safe, proper, and economical operation of the Condair GS steam humidifier, observe and comply with all information and safety instructions contained in this manual, as well as all relevant documentation of components of the installed humidification system. Comply with all local and regional regulations dealing with gas, combustion air, flue gases, water, steam and electrical systems.

If you have additional questions, contact your Condair representative. They will be glad to assist you.

## 1.1 Notes on this manual

### Limitation

The subject of this manual is the Condair GS steam humidifier in its different versions. The various options and accessories may only be described in-so-far as is necessary for proper installation and operation of the equipment. Additional information on available options and accessories can be obtained in the instructions that are supplied with them.

This manual is restricted to the operation and maintenance of the Condair GS steam humidifier, and is intended for well trained personnel who are suitably qualified for their respective tasks.

### Symbols used in this manual



**CAUTION!**

The catchword "CAUTION" used in conjunction with the caution symbol in the circle designates notes in this operation manual that, if neglected, may cause **damage and/or malfunction of the unit or damage to property**.



**WARNING!**

The catchword "WARNING" used in conjunction with the general caution symbol designates safety and danger notes in this operation manual that, if neglected, may cause **injury to persons**. Other specific warning symbols may also be used in place of the general symbol.



**DANGER!**

The catchword "DANGER" used in conjunction with the general caution symbol designates safety and danger notes in this operation manual that, if neglected, may lead to **severe injury or even death of persons**. Other specific warning symbols may also be used in place of the general symbol.

### **Other Related Publications**

This manual is supplemented by other publications such as the Installation Manual , Spare Parts List, etc., which are included in the delivery of the equipment. Where necessary, appropriate cross-references to these publications have been added in this manual.

### **Storage of Manual**

Keep this manual in a place where it is safe and readily accessible. If the equipment is moved to another location, make sure that the manual is passed on to the new user. If the manual is lost or misplaced, contact your Condair representative for a replacement copy.

### **Language Versions**

This manual is also available in other languages – contact your Condair representative.

## 2 For Your Safety

### General

Every person who is tasked with the operation and maintenance of the Condaire GS humidifier must read and understand this manual before performing any work on the unit. Knowing and understanding the contents of the Installation Manual, and the Operation and Maintenance Manual is a basic requirement for protecting personnel against any kind of danger, preventing faulty operation, and operating the unit safely and correctly.

All labels, signs and markings applied to the Condaire GS humidifier must be observed and kept in a readable state.

### Personnel Qualifications

All procedures described in this manual must only be performed by personnel who are adequately qualified, well trained and are authorized by the customer.

For safety and warranty reasons, any activity beyond the scope of this manual must only be performed by qualified personnel authorized by Condaire.

All personnel working with the Condaire GS humidifier must be familiar with, and comply with the appropriate regulations on workplace safety and prevention of accidents.

### Intended Use

The humidifier is intended exclusively for air humidification using a Condaire-approved steam distributor within specified operating conditions (refer to ["Operating Data for GS Series II Indoor Models" on page 80](#)). Any other type of application, without the express written consent of Condaire, is considered to be NOT conforming to its intended purpose, and may lead to dangerous operation and will void the warranty.

In order to operate the equipment in the intended manner all information contained in this manual, in particular the safety instructions, must be observed closely.

### Safety Precautions that Must be Observed



**DANGER!**  
Risk of electric shock!

**The Condaire GS humidifier is mains powered. Live parts may be exposed when the access panels are removed. Touching live parts may cause severe injury or even death.**

**Prevention:** Before performing any work inside the Condaire GS humidifier shut down the humidifier properly and secure it against accidental power-up as described in ["Shutting Down" on page 53](#).



**WARNING!**  
Wiring errors can cause improper and dangerous operation of the humidifier!

**Prevention:** Tag all wires before disconnecting them. Reconnect all wires correctly after servicing, and check the unit functions properly.



**CAUTION!**  
Electrostatic discharge (ESD)!

**The electronic components inside the control cabinet in the humidifier are sensitive to electrostatic discharge (ESD).**

**Prevention:** Take appropriate measures to protect the electronic components inside the unit against damage caused by electrostatic discharge (ESD).



**DANGER!**  
Risk of fire or explosion!

The Condair GS is a gas-fired humidifier. Improper installation, adjustment, alteration, service, maintenance or use can cause carbon monoxide poisoning, explosion, fire or other hazards that can cause serious injury, death or property damage.

**If over-heating occurs or if the gas fails to shut off:** Shut off the gas supply at the manual gas shutoff valve before shutting off the electrical power supply.

**DO NOT spray aerosols in the vicinity of this appliance while it is in operation.**

**DO NOT place articles on or against this appliance.**

**DO NOT use or store flammable materials in or near this appliance.**

**DO NOT use this appliance if any part has been under water.** Call a qualified service technician immediately to inspect and replace any part of the control system or gas control that has been under water.

Any work on the gas system must only be performed by a qualified installer, service agency or your local gas supplier. Use only factory-authorized and listed kits or accessories when installing or modifying this appliance.

DO NOT store or use gasoline or other flammable vapours and liquids in the vicinity of the humidifier or any other appliance.

#### **What to do if You Smell Gas:**

DO NOT try to light any appliance.

DO NOT touch any electrical switch.

DO NOT use any phone in the building.

Leave the building immediately.

Call your gas supplier immediately from a location far away from the building with the gas leak.

Follow the gas supplier's instructions.

If you cannot reach your gas supplier, call the fire department.



**WARNING!**  
Risk of severe burns from contact with hot surfaces, steam or hot water!

The tank may contain steam or hot water at up to 100 °C (212 °F). Contact with the hot surfaces, steam vapours or hot water can result in severe burns.

**Prevention:** Always drain the tank, and allow the unit to cool down to a safe temperature before cleaning the tank. Never open the tank until it has been fully drained. Never use the manual drain valve until the unit has cooled down. Use the manual drain valve to verify that the tank is empty before removing the tank cover.



**WARNING!**  
Risk of severe burns from contact with hot steam vapours!

The Condair GS humidifier produces hot steam vapours for humidification. Bare skin in contact with hot steam vapours can result in severe burns.

**Prevention:** Never perform any work on the steam system (including the steam lines, steam distributors, etc.) while the humidifier is operating. Shut down the Condair GS steam humidifier, as described in ["Shutting Down" on page 53](#) before fixing any leaks in the steam system.



**WARNING!**  
**Risk of severe burns from contact with hot surfaces!**

The water tank, steam line and exhaust gas system in the Condair GS humidifier get very hot during operation. Bare skin in contact with hot surfaces can result in severe burns.

Prevention: Shut down the Condair GS steam humidifier as described in ["Shutting Down" on page 53](#) and wait for the components to cool down before performing any work on the unit. Never use the manual drain valve until the unit has cooled down. Use the manual drain valve to verify that the tank is empty before removing the tank cover. Drain the tank as described in ["Manually Initiate Tank Draining" on page 52](#).



**WARNING!**  
**Risk of personal injury!**

Wear a safety mask and clean the burner assembly in a well ventilated area.



**CAUTION!**  
**Risk of damage to the humidifier components!**

**Do not** use solvents, aromatized or halogenized hydrocarbons, or other harsh chemicals for cleaning. Disinfectants may only be used if they do not leave behind toxic residue. Rinse all parts thoroughly with clean tap water after cleaning.



**WARNING!**  
**Risk of fire!**

**DO NOT** clean the sacrificial anode with any chemicals. The anode can react with acids to create flammable hydrogen gas.



**WARNING!**  
**Risk of damage to the humidifier components or injury!**

**DO NOT** over-torque the bolts. Ensure the proper order of torquing is followed. Failure to do so may cause damage to the humidifier components or injury.



**DANGER!**  
**Risk of harm to personnel or damage to property.**

**Operating a damaged or improperly secured humidifier presents a risk of danger to personnel or damage to property.**

**Prevention:** Do not start a damaged or improperly secured humidifier.

### Preventing Unsafe Operation

All personnel working with the unit must immediately report to the customer any alterations to the unit that may affect safety, and if it is suspected that the Condair GS steam humidifier cannot be operated safely for any of the reasons listed below, shut it down immediately as described in ["Shutting Down" on page 53](#) and secure it against accidental power-up.

- Humidifier is damaged
- Electrical connections are loose or damaged
- Humidifier is not operating properly
- Leaks in the steam system or gas supply **DO NOT** modify this appliance.

Modifications are **NOT** permitted on the Condair GS humidifier without the express written consent of Condair.

Always use original Condair replacement parts and accessories available through your Condair representative.

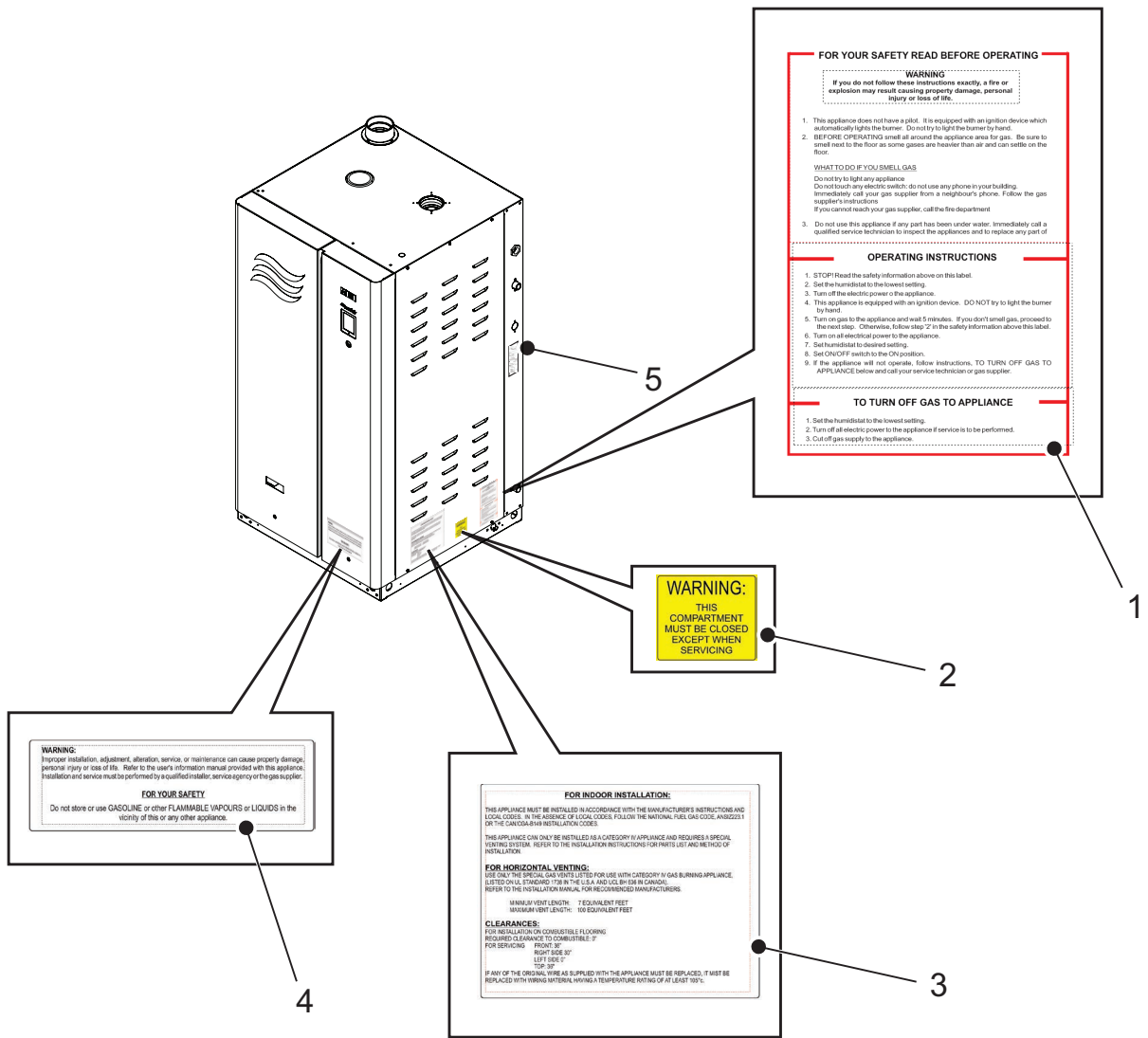

Figure 1: Safety Labels

- 1 Label, gas safety warning
- 2 Label, keep cabinet closed warning
- 3 Label, installation guidelines
- 4 Label, general safety warning
- 5 Label, specification

# 3 Product Overview

## 3.1 General Description

The Condair GS series is a completely new design of gas-fired steam humidifiers. It is designed to provide clean steam humidification at an economical price. The Condair GS humidifier is available in condensing high-efficiency (CS), ultra-low NOx condensing (NX), and Mid-Temperature models in capacities ranging from 50 lb/h to 600 lb/h (23 kg/h to 260 kg/h). The CS, MT and NX models are installed as Category IV appliances.

A high-efficiency GS CS unit operates at maximum efficiency by optimizing fuel combustion. To meet South Coast Air Quality Management District (SCAQMD) requirements, the burners are detuned, resulting in the NX model. This adjustment reduces emissions while maintaining high performance, ensuring compliance with environmental standards.

The humidifier has an integrated control board that controls the humidifier, and also allows the humidifier to be connected to a building automation system (BACnet, Lonworks, Modbus), or the internet so it can be controlled and monitored remotely. In addition, up to four humidifiers can be set up in a "Main-Extension" configuration using Condair's Linkup system to satisfy large humidification needs.

The Condair GS humidifier comes in two housing styles – compact 50-100 lb/h (23-45 kg/h), and full-size 150-600 lb/h (65-260 kg/h). Refer to [Figure 2](#).

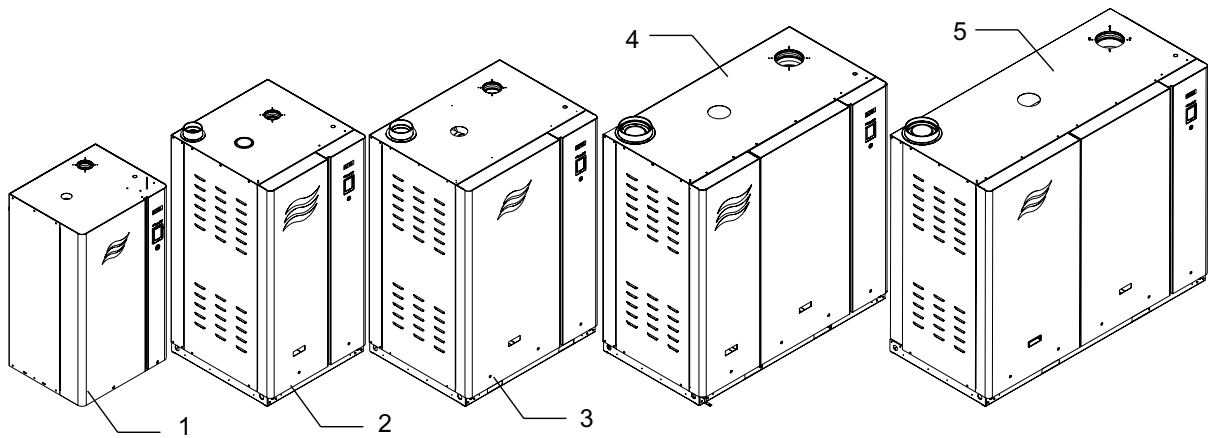

Figure 2: Condair GS-Series II Humidifiers

- |   |                                     |   |  |   |                                    |
|---|-------------------------------------|---|--|---|------------------------------------|
| 1 | Condair GS 50/100 (compact housing) | 3 | Condair GS 200/300 (full-size housing) | 5 | Condair GS 600 (full-size housing) |
| 2 | Condair GS 150 (full-size housing)  | 4 | Condair GS 450 (full-size housing)     |   |                                    |

The table below lists the summary of major components in each GS model. Refer to [Figure 3 on page 14](#).

**Table 1: Table 1: GS Components by Model**

Component	Quantity				
	Condair GS 50/100	Condair GS 150	Condair GS 200/300	Condair GS 450	Condair GS 600
Primary heat-exchanger	1	1	2	3	4
Secondary heat-exchanger	1 *	1 *	2 *	2 *	2 *
Water tank	1	1	1	1	1
Burner	1	1	2	3	4
Blower	1	1	2	3	4
Gas valve	1	1	2	3	4
Ignition control module	1	1	2	3	4
Spark-igniter and flame sensor	1	1	2	3	4
Dual fill valve	1	1	1	2	2

\* Secondary heat-exchanger on CS and NX models only.

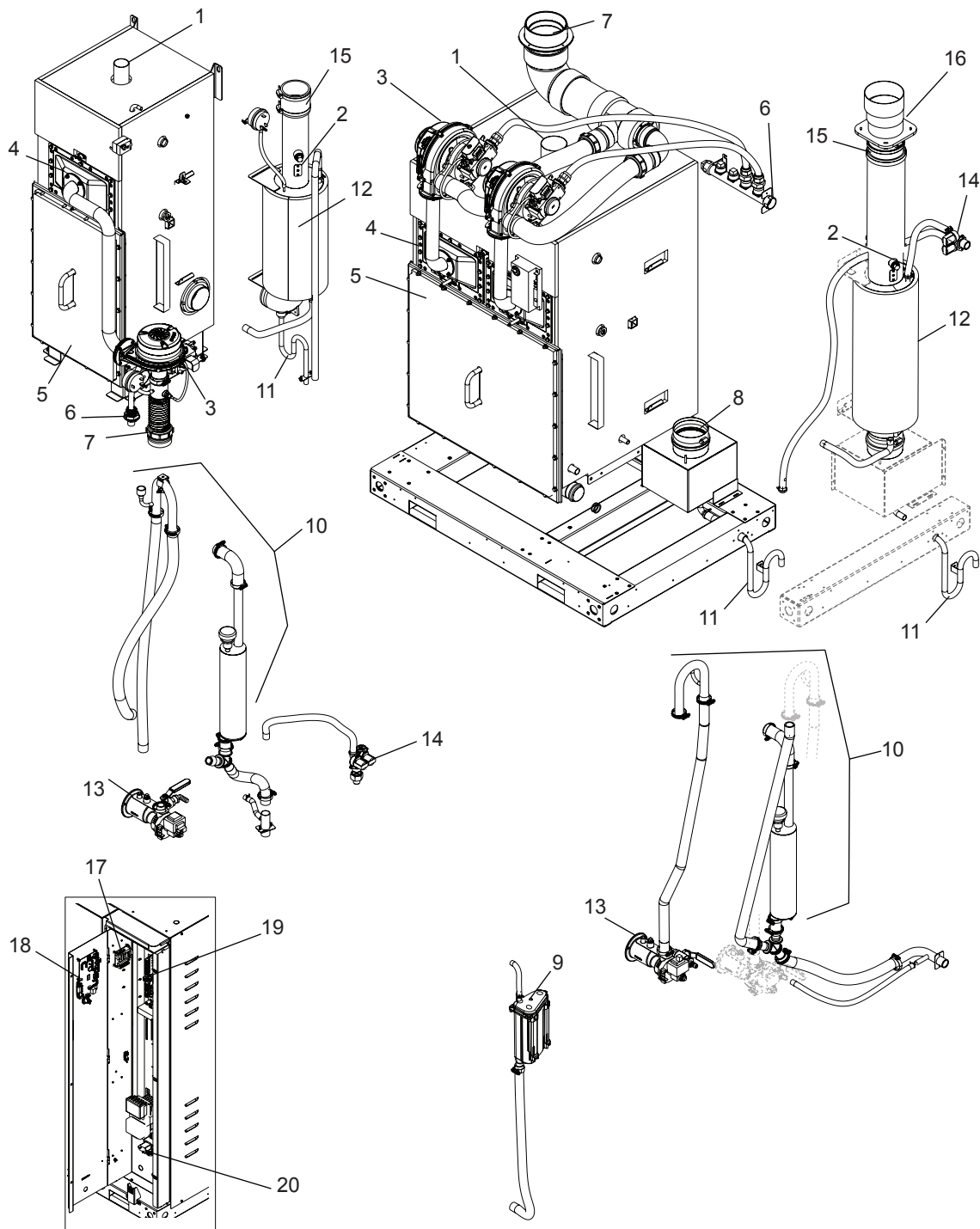

Figure 3: Humidifier Components (GS 100 and 300 shown). Door, side and top panels removed for clarity

- |   |                      |    |                                  |    |                          |
|---|----------------------|----|----------------------------------|----|--------------------------|
| 1 | Steam outlet         | 8  | Exhaust Manifold (GS 200-600)    | 15 | Silicone tube, exhaust   |
| 2 | High limit sensor    | 9  | Float chamber                    | 16 | Exhaust adapter          |
| 3 | Blower               | 10 | Overflow                         | 17 | Low voltage terminal     |
| 4 | Burner               | 11 | Condensate trap (from exhaust)   | 18 | Integrated control board |
| 5 | Tank door            | 12 | Secondary heat-exchanger (CS/NX) | 19 | PCB board                |
| 6 | Gas inlet            | 13 | Drain valve                      | 20 | High voltage terminal    |
| 7 | Combustion air inlet | 14 | Dual fill valve                  |    |                          |

## 3.2 Functional Description

### Combustion

The combustion system consists of a fully modulating forced-draft combustion air blower(s), a negative pressure regulated gas valve(s), and a premix burner(s). On a call for humidity, the blower is energized to purge the system. During this time the control software performs diagnostic checks of the safety systems – the air proving switch (not shown), the over-temperature switch and the external vent, as well as the blowers. If the air proving switch is open, the warning message "[AP Open Warn](#)" appears, and escalates to the fault message "[AP Open Fault](#)" if three consecutive warnings occur. At the same time, if the over-temperature switch is open, the fault message "[Over-Temperature Fault](#)" appears. In addition, if any of the blowers fail to operate during this time, the fault message "[Blower Not Operating](#)" appears. When the functions of the safety systems have been verified successfully, the gas valve(s) opens and the gas-air mixture is pushed through the burner ports into the combustion chamber(s). The spark-igniter(s) is simultaneously activated to ignite the gas-air mixture.

If a flame is not sensed by the flame sensor(s), the above sequence is repeated after 15 seconds. The sequence is repeated up to a maximum of three times, after which the ignition control module(s) locks out and the fault message "[Ignition Fail](#)" appears. If a flame is sensed by the flame sensor(s), the gas valve(s) remains open and combustion continues. The gas valve(s) continues to maintain a constant air-to-gas ratio independent of the blower speed or external conditions.

On the CS and NX models, the hot flue gases pass through the primary heat-exchanger then the secondary heat-exchanger, where it is cooled further before it exits through the exhaust vent. The heat recovered by the secondary heat-exchanger is used to warm up the feed water. On the standard-efficiency model, the hot flue gases pass through the primary heat-exchanger and exit through the exhaust vent.

### Water Management

The humidifier is equipped with a float chamber that monitors the water level in the tank.

The tank is supplied with water from the water supply, and from the secondary heat exchanger in CS and NX models. A vacuum break valve is used to prevent siphoning in the drain connection.

In the CS and NX model, a secondary heat-exchanger promotes higher efficiencies. This is achieved by using the heat from the exhaust to pre-heat the cold fill water entering the tank.

The float chamber is connected to the top and bottom of the tank to monitor water levels with reference to the low operational pressure inside the tank. The float chamber and its control board consists of two magnetic floats (one is a backup) that measure the water level. These levels correspond to 3 LEDs on a display panel and are monitored by the control software.

#### Water Levels:

L5 (yellow LED) — high water level	L2 (green and red LED) — intermediate water level
L4 (green and yellow LED) — intermediate water level	L1 (red LED) — low water level
L3 (green LED) — middle water level	

On initial start-up, the dual fill valves fill the tank and the float chamber. A start-up test monitors the water level as the tank and float chamber fills, and ensures proper functioning of the unit.

**Note:** A fault message "Float Level" may appear at any time. This indicates an invalid combination of readings from the control software (for example, if L5 and L1 LEDs activate at the same time).

1. The water level reaches the backup float, then the main float.
2. As water fills the float chamber and reaches the L1 level, the control software performs a test to verify proper functioning of the dual fill valves and the drain pump.
  - a. Water enters the float chamber via the tank. The fill valves will allow water to fill the tank and raise the water level in the float chamber to L5.
  - b. The drain pump energizes to lower the water level to just below L3.

**Note:** The water levels should appear in ascending then descending order; L1, L2, L3, L4, L5, L4, L3. A fault message "Fill Check Fault" appears if the water level does not rise to level L5. A fault message "Drain Check" appears if the water level does not drop below the level L3.

3. When the test is complete, the dual fill valves activate and the water level should rise to level L3.
4. If a demand signal is present, the humidifier begins the combustion sequence.
5. The drain pump and dual fill valves maintain the water level between levels L2 and L5.

If Float Check is enabled during steam production, the control software will activate the drain sequence every 24 hours (adjustable to any time of day) to verify proper functioning of the floats, dual fill valves, and the drain pump.

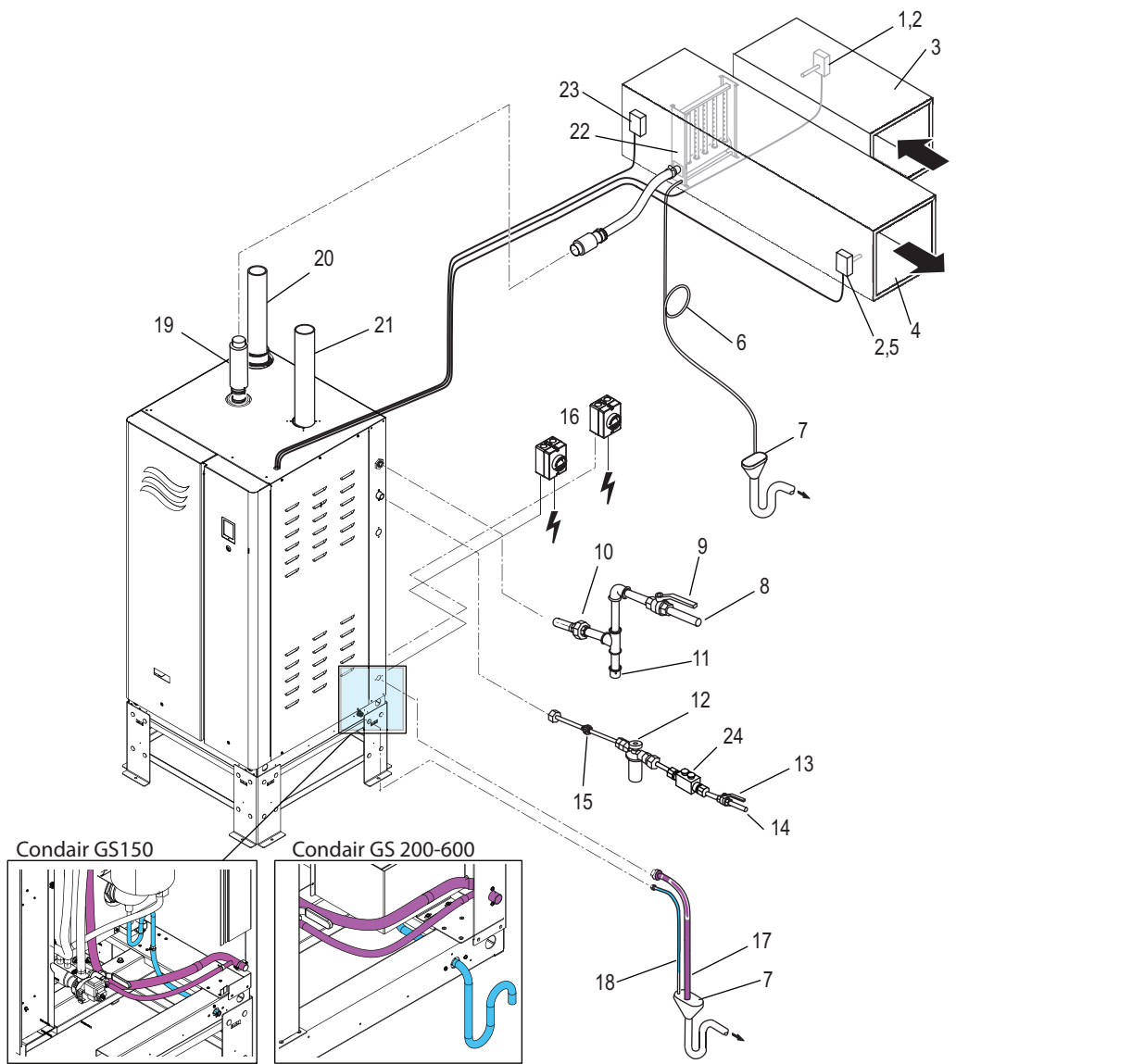

Figure 4: General System Overview (full-size unit Condair GS 150 shown)

- |   |  |    |  |    |  |
|---|--|----|--|----|--|
| 1 | Humidistat, On/Off (used for humidity control)   | 9  | Manual gas shutoff valve                         | 19 | Steam line   |
| 2 | Humidity sensor or modulating humidistat (used for control of the space in the return duct, high limit in the supply duct) | 10 | Fitting, union                                   | 20 | Vent, air intake (connected to exterior – optional)        |
| 3 | Duct, return air   | 11 | Trap, sediment                                   | 21 | Vent, exhaust vent (connected to exterior)                 |
| 4 | Duct, supply air   | 12 | Filter, water (optional, but recommended)        | 22 | Distributor, steam   |
| 5 | Humidistat, On/Off, high limit (external security loop)  | 13 | Valve, water shutoff                             | 23 | Switch, air proving (external security loop)               |
| 6 | Drain line, condensate (with trap)   | 14 | Supply line, water                               | 24 | Double check valve backflow preventer (supplied by others) |
| 7 | Funnel, air gap (with optional trap)   | 15 | Fitting, union                                   |    |  |
| 8 | Supply line, gas   | 16 | Switch, disconnect, electrical fused (dedicated) |    |  |
|   |  | 17 | Drain line                                       |    |  |
|   |  | 18 | Drain line, exhaust condensate (CSNX model only) |    |  |

# 4 Operator Interface

## 4.1 Controls

The operator interface in the Condair GS humidifier is located on the front of the unit – refer to [Figure 5](#). It consists of a touchscreen display with a LED status indicator, and an On/Off switch. Refer to [Table 2](#) for a description of each of these elements.

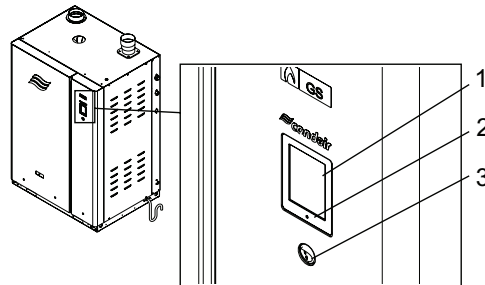

Figure 5: Operator Interface

- 1 Display, touchscreen
- 2 Status indicator, LED
- 3 Switch, On/Off



**DANGER!**  
Risk of electric shock!

**The control cabinet in the humidifier has live voltage. Turning off the unit at the On/Off switch does not shut off power to the control cabinet, which still has live voltage. Touching live parts may cause severe injury or even death.**

**Prevention:** Shut down the humidifier properly as described in ["Shutting Down" on page 53](#) before accessing the control cabinet in the humidifier.

Table 2: Operator Interface Element Functions

Element	Description
Touchscreen display	Allows the user to monitor or control the Condair GS humidifier. Refer to <a href="#">"Control Software" on page 19</a> for details of the software interface.
LED status indicator	The status LED is a multi-function LED, which lights up in different colours depending on the operating status of the humidifier. Green: indicates that the Condair GS humidifier is operating normally and humidifying. Flashing Green: indicates that the Condair GS humidifier is in standby mode. Yellow: indicates that a warning condition is present, or the humidifier is due for maintenance. Red: indicates that a fault condition is present, and humidification is stopped.
On/Off switch	Allows the user to turn the Condair GS humidifier on or off.

## 4.2 Control Software

### 4.2.1 Home Screen

When the Condair GS humidifier is turned on, it starts initializing and performs system checks. When initialization and system checks are completed successfully, it goes into the normal operating mode. The Home screen then appears on the touchscreen display.

The major elements of the Home screen are shown in [Figure 6](#).

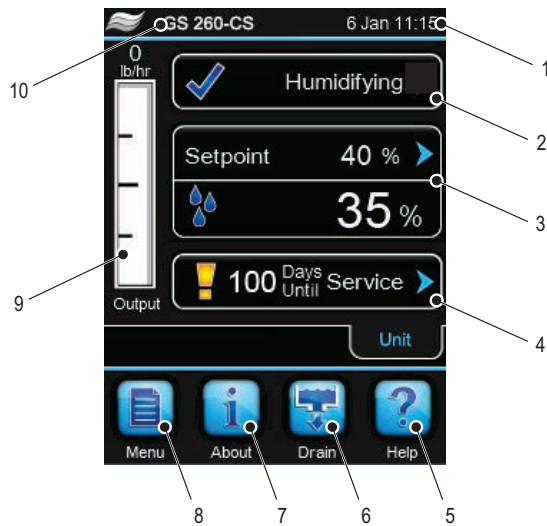

**Figure 6: Home Screen Elements**

- |   |   |   |  |    |  |
|---|---|---|--|----|--|
| 1 | Date and time, Current  | 4 | Service/Warning/Fault status message – refer to <a href="#">"Maintenance and Fault Status" on page 21</a> for details.                     | 7  | Button, <About> – access the system information. Refer to <a href="#">"System Information" on page 22</a> for details. |
| 2 | Operating status message – refer to <a href="#">"Operating Status" on page 20</a> for details.  | 5 | Button, <Help> – access technical support help information. Refer to <a href="#">"Help" on page 21</a> for details.                        | 8  | Button, <Menu> – access the Main menu. Refer to <a href="#">"Main Menu" on page 27</a> for details.                    |
| 3 | Humidity control information – shows the type of control signal and the steam output requested. | 6 | Button, <Drain> – manually initiate the drain function. Refer to <a href="#">"Manually Initiate Tank Draining" on page 52</a> for details. | 9  | Visual indication, current steam output level  |
|   |   |   |  | 10 | Model number, humidifier   |



## 4.2.2 Operating Status

The operating status area of the Home screen (refer to [Table 3](#)) shows the current operating status message and an associated status icon. The messages are described in [Table 3](#), and the status icons are described in [Table 4](#).

*Table 3: Operating Status Descriptions*

Message	Description
Humidifying	The humidifier is generating steam.
Stopped	The humidifier is stopped because a condition with a "Fault" status is active.
Disabled	The Condair humidifier is disabled by the BMS (building management system).
Safety Loop	One or more contacts in the external security loop is open, so the humidifier has stopped producing steam.
Idle	The humidifier is in standby mode (no humidity demand). The humidifier will remain in this state until it receives a valid humidity demand signal.
Idle Drain	The humidifier is in standby mode (no humidity demand) and will remain in this state until a demand signal is received, or until the <a href="#">Idle Drain Time</a> has elapsed (and the <a href="#">Idle Drain</a> function is active). The humidifier will drain when <a href="#">Idle Drain Time</a> has elapsed.
Idle Empty	Indicates that the tank is empty during idle.
Keep Warm	The humidifier is in standby mode, and the <a href="#">Keep Warm</a> function is activated.
Filling	Indicates that the tank is being filled.
Fill check	The humidifier is performing a fill check.
Drain check	The humidifier is performing a drain check.
Draining	The humidifier is draining.

*Table 4: Status Icon Descriptions*

Icon	Description
	The icon appears to the left of the operating status message or the maintenance/fault message when the system is working normally.
 Warning	The icon appears to the left of the maintenance/fault status message when a maintenance reminder or a condition with a "Warning" status is active. The humidifier will continue to produce steam when there is a demand (unless the warning relates to a control signal). A condition with a "Warning" status is active. Typically, these conditions are of a temporary nature, or conditions that cannot cause damage to the system. Depending on the condition, the Condair GS humidifier may be stopped or remains operable (unless the warning relates to a control signal). If the cause of the condition clears on its own accord, the warning message is automatically reset. If the condition becomes worse, a fault message may be triggered. When a warning message is active, the status LED turns yellow in color.
 Fault	The icon shown appears to the left of the maintenance/fault status message when a condition with a "Fault" status is active. The humidifier stops producing steam. A condition with a "Fault" status is active. Typically, these are conditions which prevent further operation of the humidifier, or conditions that can cause damage to the system. When a fault condition occurs, the Condair GS humidifier stops steam production immediately. When a fault message is active, the status LED turns red in color.

### 4.2.3 Maintenance and Fault Status

The Service/Warning/Fault status area of the Home screen (refer to [Table 5](#)) shows maintenance reminders, warning and fault status messages along with associated status icons. This field also allows access to the "[Service Menu](#)". When a maintenance reminder, warning or fault status message is active, the list of current faults/warnings can be accessed directly from this field to view additional details.

The general maintenance reminders and alarm messages displayed in this area are described in [Table 5](#), and the status icons are described in [Table 4 on page 20](#). Refer to "[Warning and Fault List](#)" on page 72 .

*Table 5: Maintenance/Fault Status Descriptions*

Message	Description
Service info	No faults conditions present.
Maint. Warning	This maintenance reminder appears when the <a href="#">Service Interval</a> time set in the control software has elapsed. The unit can continue to operate for another 200 hours, after which a corresponding fault message appears and the unit stops operating. Perform the required scheduled maintenance, then reset the service reminder in the Service menu. Refer to " <a href="#">Maintenance Procedures</a> " on page 60.
Warning	A condition with a "Warning" status is active. Depending on the warning condition, the humidifier will continue to produce steam when there is a demand (unless the warning relates to a control signal). In addition, the status LED turns yellow in colour.
Fault	A condition with a "Fault" status is active. The humidifier will not produce steam until the fault condition is cleared. In addition, the status LED turns red in colour.

### 4.2.4 Help

Touch the <Help> button on the Home screen (refer to [Figure 6 on page 19](#)) to view your local technical support help details.

## 4.2.5 System Information

Select the <About> button on the Home screen (refer to [Figure 6 on page 19](#)) to view the system information for your Condair GS humidifier. The tab structure for this selection is shown below.

### General Tab



- **Serial Number:** shows the serial number, which is also shown on the specification label.
- **Humidifier Model:** shows the model number, which is also shown on the specification label (on the right side of the humidifier).
- **Humidifier Capacity:** shows the total steam output capacity of the humidifier.
- **Software Version:** shows the current version of the control software. Select the field to update the control software – refer to ["Software Settings Tab" on page 46](#) for details.
- **Driver Board A/B Version:** shows the current version of the driver board.
- **Graph:** shows you a trend data.
- **Export Trend Data:** sends the data to a connected USB drive.

### Timer Tab



- **On/Off Timers:** allow you to enable or disable the On/Off timer function to permit disabling of steam production during specified days and times.  
Configuration > Features > Operation > On/Off Timers
- **Capacity Timers:** allow you to enable or disable the timer function, and configure up to eight different events with different output capacities. The event timers for the capacity set in  
Configuration > Features > Operation > Capacity Timers

## Operational Status Tab

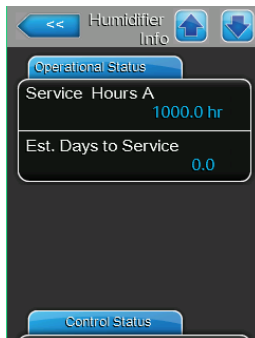

- **Output:** shows the current actual steam output level of the humidifier.
- **Operating Hours:** shows the current accumulated number of hours the humidifier has been producing steam since startup.
- **Weighted Hours:** shows the number of operating hours on the unit weighted x demand % output.
- **Average Demand:** shows the time-averaged demand on the system.
- **Service Hours:** shows the service interval.
- **Est(imated) Days to Service:** shows the number of days before the unit is due for service (based on average humidifier demand).

## Control Status Tab

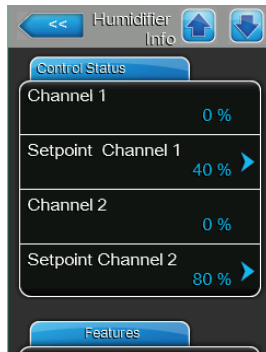

- **Demand:** shows the calculated demand for the unit as a percentage of its maximum capacity.
- **Linkup:** shows the humidifier's 'position' in the linkup chain. Select to set the humidifier
- **Safety Loop:** shows the current status of the On/Off devices in the safety loop. If the loop is open, the unit will not produce steam.
- **Manual Capacity:** shows the capacity limitation value as a percentage of the maximum capacity of the unit. Select the field to set a fixed maximum output capacity.
- **Channel 1:** shows the input signal for Channel 1. If configured for demand control, it represents the demand. If configured for RH(P/PI), it represents sensed humidity.
- **Setpoint Channel 1:** shows the current fixed humidity setpoint value for the unit. Select the field to adjust the setpoint value. Refer to ["PI Control Parameters Tab" on page 33](#) for more details.  
**Note:** This field appears only if [Control Mode](#) is set to "RH P" or "RH PI".
- **Channel 2:** shows the input signal for Channel 2. If configured for demand control, it represents the demand. If configured for RH(P/PI), it represents sensed humidity.  
**Note:** This field appears only if the [Control Channels](#) is set to "Dual".
- **Setpoint Channel 2:** shows the high limit setpoint value for the unit. Select the field to adjust the value.  
**Note:** This field appears only if [Control Mode](#) is set to "RH P" or "RH PI", and [Control Channels](#) is set to "Dual".

## Features Tab

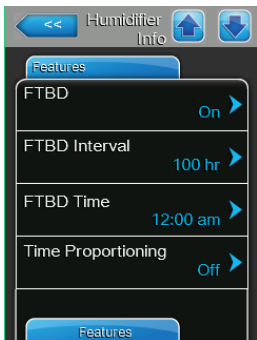

- **Blowdown Rate:** shows the rate at which the tank is partially drained, as a percentage of actual steam production. Refer to the ["Water Management Tab" on page 29](#) for more details.
- **Drain Cool:** shows the configuration setting of the drain cool function. Select the field to choose a different mode – "Off", "On" or "Smart". Refer to the ["Water Management Tab" on page 29](#) for more details.
- **Float Check:** shows the configuration setting of the float check function. Select the field to enable or disable the function. Refer to the ["Operation Tab" on page 31](#) for more details.
- **Float Check Time:** allows you to see and set the time of day when the float check function will occur.
- **FTBD (Full Tank Blowdown):** shows the configuration setting of the full tank blowdown function. Select the field to enable or disable the function. Refer to the ["Water Management Tab" on page 29](#) for more details.
- **FTBD Interval:** shows how often a full tank blowdown will occur. Refer to the ["Water Management Tab" on page 29](#) for more details.
- **FTBD Time:** shows the time of day when a full tank blowdown will occur. Refer to the ["Water Management Tab" on page 29](#) for more details.
- **Time Proportioning:** shows the configuration setting of the time proportioning function. Select the field to enable or disable the function. Refer to the ["Operation Tab" on page 31](#) for more details.
- **Idle Mode:** allows you to set the idle function of the humidifier when it is in standby mode.
- **Idle Drain Time:** allows you to set the time duration the humidifier stays in standby mode without a demand, after which the humidifier carries out the function specified in [Idle Mode](#).
- **Short Cycle:** allows you to enable or disable a timer function that delays steam production until the already delivered humidity can stabilize in the conditioned environment. This feature prevents the humidifier from flooding the environment with excess humidity from false humidity readings.
- **Short Cycle Time:** allows you to set the time duration that the unit waits in standby mode before responding to a new demand signal.

## Networking Settings Tab

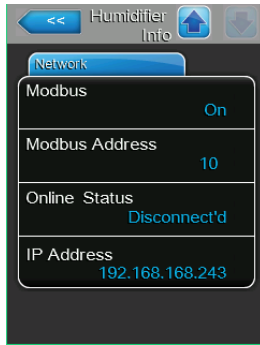

- **Modbus:** shows Modbus communication. Options shown: Off, Modbus/RTU, or Modbus/TCP.
- **Modbus Address:** shows the Modbus address.
- **BACnet MSTP MAC:** shows the MAC address assigned to the humidifier.
- **IP Address:** shows the IP address assigned to the humidifier.

## 4.2.6 Main Menu

Select the <Menu> button on the Home screen to view the Main menu. The Main menu and its contents are password-protected. Refer to [Figure 7](#). Enter the password "0335" to access the Main menu.

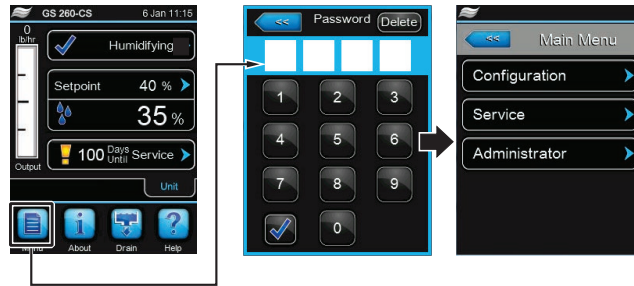

Figure 7: Main Menu Access

The structure of the Main menu and its sub-menus is shown in [Table 6](#).

Table 6: Main Menu Structure

<a href="#">"Main Menu" on page 27 &gt;</a>	<a href="#">"Configuration Menu" on page 28 &gt;</a>	<a href="#">"Features Menu" on page 29 &gt;</a>	<a href="#">"Water Management Tab" on page 29</a>
			<a href="#">"Operation Tab" on page 31</a>
		<a href="#">"Control Settings Menu" on page 32 &gt;</a>	<a href="#">"Basic Tab" on page 32</a>
			<a href="#">"PI Control Parameters Tab" on page 33</a>
			<a href="#">"RH Alerts Tab" on page 34</a>
			<a href="#">"Multi-Unit Operation Tab" on page 35</a>
		<a href="#">"General Menu" on page 37 &gt;</a>	<a href="#">"Basic Tab" on page 37</a>
			<a href="#">"Time Date Tab" on page 37</a>
		<a href="#">"Communications Menu" on page 38 &gt;</a>	<a href="#">"Remote Enable Tab" on page 38</a>
			<a href="#">"IP Parameters Tab" on page 38</a>
			<a href="#">"BMS Timeout Tab" on page 39</a>
			<a href="#">"Modbus Parameters Tab" on page 39</a>
			<a href="#">"BACnet Parameters Tab" on page 39</a>
		<a href="#">"Remote Fault Board Tab" on page 41</a>	
	<a href="#">"Service Menu" on page 42</a>	<a href="#">"Humidifier Service Tab" on page 42</a>	
		<a href="#">"General Service Tab" on page 42</a>	
		<a href="#">"Fault/Service History Tab" on page 43</a>	
	<a href="#">"Diagnostics Tab" on page 43 &gt;</a>		<a href="#">Input Diagnostics</a>
			<a href="#">Output Diagnostics</a>
			<a href="#">Relay Diagnostics</a>
	<a href="#">"Setpoint" on page 44</a>		
	<a href="#">"Administrator Menu" on page 45 &gt;</a>	<a href="#">"Password Setting Tab" on page 45</a>	
		<a href="#">"Software Settings Tab" on page 46</a>	

### 4.2.6.1 Configuration Menu

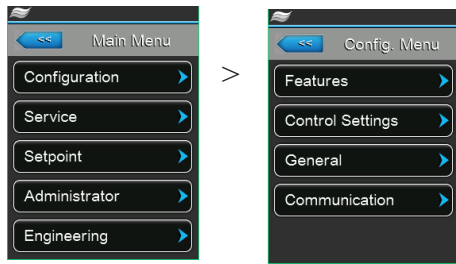

The Configuration menu lets you configure the operation of the Condair GS humidifier. The menu and sub-menu items are discussed below. Refer to [Table 6 on page 27](#) for the menu structure.

## Features Menu

Each tab under the Features menu is discussed below.

### Water Management Tab

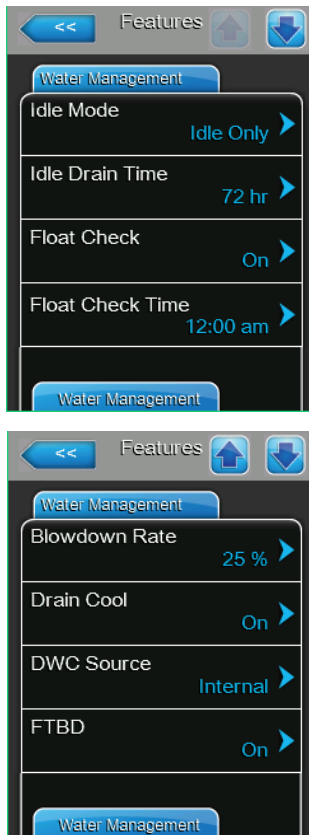

- **Idle Mode:** allows you to set the idle function of the humidifier when it is in standby mode.  
Options:
  - Idle Only* – the humidifier waits indefinitely for a demand signal.
  - Idle Drain* – the tank is drained after [Idle Drain Time](#) elapses without demand.
  - Keep Warm* – the water in the tank is kept warm while in standby mode.Factory setting: *Idle Drain*
- **Idle Drain Time:** allows you to set the time duration the humidifier stays in standby mode without a demand, after which the humidifier carries out the function specified in [Idle Mode](#).  
Setting range: *1-100 h*  
Factory setting: *72 h*
- **Float Check:** allows you to enable or disable the float check function. When enabled, the humidifier performs a float check at start-up and every 24 hours (without interrupting steam production if humidifier is operating, or in standby mode), to verify that the float system is working properly. .  
Options: *On or Off*  
Factory setting: *On*
- **Float Check Time:** allows you to set the time of day when the float check function will occur.
- **Blowdown Rate:** allows you to set the rate (as a percentage of actual steam production) at which the tank is drained. Refer to ["Adjusting Blowdown Settings" on page 59](#) for additional details.  
Setting range: *1-50%*  
Factory setting: *25%*
- **Drain Cool:** allows you to enable or disable the drain water cooling function that is used to cool down the drain water before it is discharged.  
Options:
  - On* – enable the function.
  - Off* – disable the function.
  - Smart* – drain water cooling happens only if the tank is hot.Factory setting: *On*
- **DWC (Drain Water Cooling) Source:** allows you to select the water source used in drain water cooling.  
Options:
  - Internal* – use the fill valve in the unit to supply water for drain water cooling
  - Seperate* – use an alternate source to cool the drain water (only for DWC setting)Factory setting: *Internal or Seperate*



- **FTBD (Full Tank Blowdown):** allows you to enable or disable the full tank blowdown function. Depending on the water quality, this function can be used to extend operational life and service intervals by reducing mineral build-up in the tank. When enabled, the FTBD function performs a full drain of the tank when the weighted runtime hours exceed the *FTBD Interval*. When blowdown is completed, the tank is refilled and the unit resumes normal operation.

Options: *On or Off*

Factory setting: *On*

- **FTBD Time:** allows you to set the time of day when a full tank blowdown will occur.

- **FTBD Interval:** allows you to set the frequency of full tank blowdowns in weighted hours (equivalent to a unit operating at 100% output). Refer to ["Adjusting Blowdown Settings" on page 59](#) for additional details.

Setting range: *1-200 h*

Factory setting: *100 h*

- **Fill Correction 1:** allows you to adjust all the parameters for the high volume fill valve(s) to compensate for valve tolerances, as well as site-specific conditions.

---

**CAUTION!** Do not adjust this value unless instructed to do so by a Condair representative.

---

Setting range: *0.1-2.0*

Factory setting: *1.0*

- **Fill Correction 2:** allows you to adjust all the parameters for the low volume fill valve(s) to compensate for valve tolerances, as well as site-specific conditions.

---

**CAUTION!** Do not adjust this value unless instructed to do so by a Condair representative.

---

Setting range: *0.1-2.0*

Factory setting: *1.0*

- **Drain Correction:** allows you to adjust all the parameters used for draining the tank and blowdowns to compensate for drain pump flow rates and site-specific conditions.

---

**CAUTION!** Do not adjust this value unless instructed to do so by a Condair representative.

---

Setting range: *0.5-1.5*

Factory setting: *1.0*

## Operation Tab

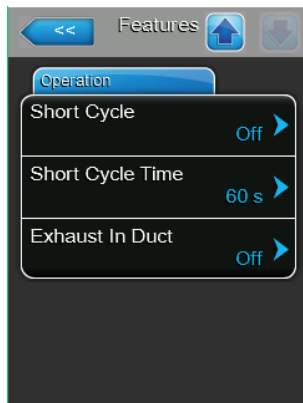
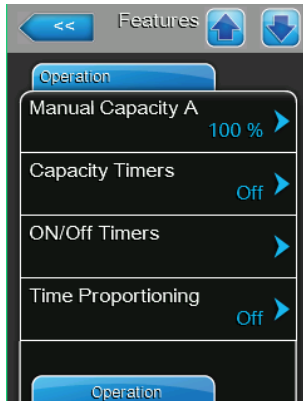

- **Manual Capacity:** allows you to set the capacity limitation value as a percentage of the maximum capacity of the unit.  
Setting range: 20-100 %  
Factory setting: 100 %
- **Capacity Timers:** Present status of the timer controlled capacity limitation ("On": timer controlled capacity limitation activated, "Off": timer controlled capacity limitation deactivated).
- **On/Off Timers:** Present status of the On/Off timer function ("On": On/Off timer function activated, "Off": On/Off timer function deactivated). A warning message is displayed whenever the humidifier is turned off via the On/Off timer.
- **Time Proportioning:** allows you to enable or disable the time proportioning function, which allows the controller to operate the burners on a time-proportional sequence when the system demand is below the minimum output of a single burner.  
Options: On or Off  
Factory setting: Off
- **Short Cycle:** allows you to enable or disable a timer function that delays steam production until the already delivered humidity can stabilize in the conditioned environment. This feature prevents the humidifier from flooding the environment with excess humidity from false humidity readings.  
Options: On – the humidifier remains in standby mode until the timer elapses even if there is a new demand signal.  
Off – disables the timer function.  
Factory setting: Off
- **Short Cycle Time:** allows you to set the time duration that the unit waits in standby mode before responding to a new demand signal.  
Setting range: 0-300 s  
Factory setting: 60 s
- **Exhaust in Duct:** When set to ON, terminal 9 on the Low Voltage terminal strip is monitored at all times for a 24V input. This input behaves similarly to the security loop but is used for the on/off controls required for the Exhaust in Duct feature. At any time, if the on/off controls open and the 24V is lost on the terminal 9 input, a E153 Exhaust in Duct Fault is generated and humidification will stop immediately. A power cycle reset is required to clear the fault. In addition to setting the feature in the software, a jumper selection needs to be made on the driver board. JP1 needs to be moved to position 2-3.  
Options: On or Off  
Off – When set to OFF, all of the above is ignored. JP1 should be in position 1-2..
- Factory setting: Off

## Control Settings Menu

Control Settings menu is discussed below. Refer to the structure of the tabs in [Table 6 on page 27](#).

### Basic Tab



- **Source:** allows you to select the source of incoming control/humidity signal to the humidifier.

Options: *Analog* – signals from analog sensors or humidistats connected to the humidifier's low voltage terminal block.  
*Modbus* – signals from BMS via the Modbus communication protocol.  
*BACnet* – signals from the BMS via the BACnet/IP or BACnet/MSTP communication protocol.

Factory setting: *Analog*

- **Control Channels:** select one or two control signals to control the humidifier.

Options: *Single* – single control signal.  
*Dual* – two control signals (typically a control, plus a high limit signal).

Factory setting: *Single*

- **Control Mode CH 1:** select the general control mode for the incoming control signal.

Options: *Demand* – signal from an external controller.  
*RH P* – uses the internal (proportional) controller to interpret the sensed humidity into a demand.

*RH PI* – uses the internal (proportional-integral) controller to interpret the sensed humidity into a demand.

*On/Off* – control signal is from an external On/Off humidistat.

Factory setting: *Demand*

- **Limiter Mode CH2:** only appears when control mode is set to double. Allows you to set the limiter signal type.

- **Signal Type Channel 1:** select the signal type of the incoming control signal. **Note:** This setting is ignored if signal [Source](#) is not set to "Analog".

Options: *0-5V, 1-5V, 0-10V, 2-10V, 0-20V, 0-16V, 3.2-16V, 0-20mA, 4-20mA*

Factory setting: *0-10V*

- **Signal Type Channel 2:** select the signal type for the high limit signal. **Note:** This setting is ignored if signal [Source](#) is not set to "Analog". Channel 2 applies only when [Control Channels](#) is set to "Dual".

Options: *0-5V, 1-5V, 0-10V, 2-10V, 0-20V, 0-16V, 3.2-16V, 0-20mA, 4-20mA*

Factory setting: *0-10V*

## PI Control Parameters Tab

**Note:** This tab appears only if [Control Mode](#) is set to "RH P" or "RH PI".



- **Setpoint Channel 1:** allows you to set the humidifier to operate at a fixed humidity setpoint value.

Setting range: *0-95% RH*  
 Factory setting: *40%*

- **Band Channel 1/2:** allows you to set the proportional range for the internal P/PI controller as a percentage of relative humidity (% RH) within which the humidifier will modulate between 0 and 100% output. **Note:** Band channel 2 setting appears only if [Control Channels](#) is set to "Dual".

---

**CAUTION!** Do not adjust this value unless instructed to do so by a Condaire representative.

---

Setting range: *6-65%*  
 Factory setting: *15%*

- **ITime Channel 1:** allows you to set the integral time for error corrections by the internal P/PI controller.

---

**CAUTION!** Do not adjust this value unless instructed to do so by a Condaire representative.

---

Setting range: *1-60 minutes*  
 Factory setting: *5 minutes*

- **Setpoint Channel 2:** allows you to set the high limit setpoint value. **Note:** This setting appears only if [Control Channels](#) is set to "Dual".

Setting range: *0-95% RH*  
 Factory setting: *80%*

- **Damp Channel 2:** allows you to set the time duration after which the high limit setpoint value takes control of the demand signal. **Note:** This setting appears only if [Control Channels](#) is set to "Dual".

Setting range: *1-60 s*  
 Factory setting: *5 s*



## RH Alerts Tab

**Note:** This tab appears only if [Control Mode](#) is set to "RH P" or "RH PI".



- **RH Alerts:** allows you to enable or disable the alert function that warns if sensed humidity is too high or too low.

Options:                    *On* – enables the function.  
                                  *Off* – disables the function.

Factory setting:        *Off*

**Note:** The following settings are only available if the RH Alerts function is enabled.

- **RH High:** allows you to set the upper limit value of the humidity sensor signal. The RH High warning message is triggered when the signal value exceeds this limit.

Setting range:        *20-95%*

Factory setting:       *75%*

- **RH Low:** allows you to set the lower limit value of the humidity sensor signal. The RH Low warning message is triggered when the signal value drops below this limit.

Setting range:        *20-95%*

Factory setting:       *20%*

- **Sensor Min:** allows you to set the minimum signal value of the humidity sensor. If the signal value drops below this setting, the sensor is assumed to be damaged or disconnected. The RH Signal warning message is triggered when the signal value drops below this limit, and humidification stops.

Setting range:        *1-10%*

Factory setting:       *5%*

## Multi-Unit Operation Tab



- **Linkup:** allows you to enable or disable the Linkup function, which allows up to six humidifier to connect and operate together from a single set of control signals. It also allows you to designate the humidifier to operate as a "Main" or "Extension" unit.

Options:                    *Main* – designated as the main (master) unit.  
                                  *Ext 1* – designated as the first extension unit.  
                                  *Ext 2* – designated as the second extension unit.  
                                  *Ext 3* – designated as the third extension unit.  
                                  *Ext 4* – designated as the fourth extension unit.  
                                  *Ext 5* – designated as the fifth extension unit.  
                                  *Off* – disables Linkup. The humidifier performs as a single unit.

Factory setting:        *Off*

**Note:** The remaining settings in this tab and the next are only available on the main unit when the Linkup function is enabled.

- **Linkup Units:** allows you to set the number of humidifiers in the Linkup chain.

Setting range:            *1-6*

Factory setting:        *1*

- **Linkup Type:** allows you to select the mode of operation of the humidifier in the Linkup chain.

Options:                    *Parallel* – the humidity demand (from a single zone) is distributed evenly on all humidifiers in the Linkup chain.

*Series* – the main unit operates to its maximum capacity, and as demand increases the extension units generate steam in sequential order. Each unit scales steam production in small increments. Series setting maximizes turndown.

Factory setting:        *Series*

- **Sequence Rotation:** allows you to enable or disable the function that manages the starting order to balance operating hours of all linked humidifiers. **Note:** This setting is available only if [Linkup Type](#) is set to "Series".

Options:                    *On or Off.*

Factory setting:        *On*

## Multi-Unit Operation Tab, continued...

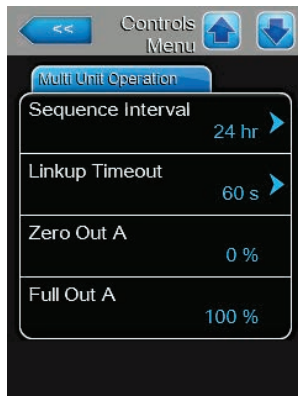

- **Sequence Interval:** allows you to set the time interval used by the control software to establish a new operating sequence to balance operating hours of linked humidifiers. **Note:** This setting is available only if [Sequence Rotation](#) is enabled.  
Setting range: 24-1000 h  
Factory setting: 24 h
- **Linkup Timeout:** allows you to set the maximum time limit that the units in the Linkup chain can operate without communication to each other before a timeout warning message is generated.  
Setting range: 60-120 s  
Factory setting: 60 s
- **Zero Out:** shows the percentage value of the system demand signal at which the unit is switched on.  
Setting range: 0-100%  
Factory setting: 0%  
**Note:** This setting can only be modified if more than one unit is physically connected to the Linkup chain.
- **Full Out:** shows the percentage value of the system demand signal at which the unit achieves 100% demand.  
Setting range: 0-100%  
Factory setting: 100%  
**Note:** This setting can only be modified if more than one unit is physically connected to the Linkup chain.

Refer to ["Configuring for Multi-Unit Operation" on page 48](#) for setup procedure.

## General Menu

Each tab under the General menu is discussed below. Refer to [Table 6 on page 27](#) for the menu structure.

### Basic Tab

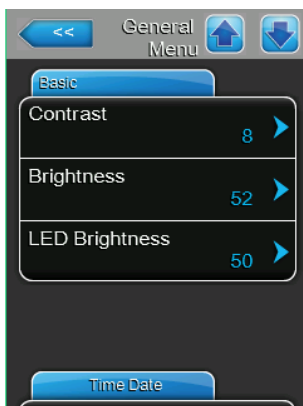
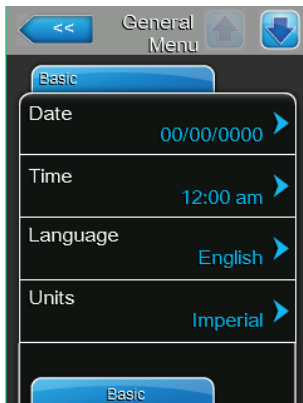

- **Date:** allows you to set the current date in MM/DD/YYYY or DD/MM/YYYY format depending on the [Date Format](#) setting.
- **Time:** allows you to set the current time in 12-hour or 24-hour format depending on the [Clock Format](#) setting.
- **Language:** allows you to select the language displayed on the touchscreen display.  
Options: *English, German, French, Italian, Spanish, Dutch, Danish, Finnish, Swedish, Polish, Czech, Hungarian, Russian, Japanese or Chinese*
- **Units:** allows you to select the units of measurement.  
Options: *Imperial or Metric*
- **Contrast:** allows you to set the contrast level of the touchscreen display.  
Setting range: *1 (low) - 31 (high)*  
Factory setting: *8*
- **Brightness:** allows you to set the brightness level of the touchscreen display.  
Setting range: *1 (black) - 100 (white)*  
Factory setting: *52*
- **LED Brightness:** allows you to adjust the brightness of the LEDs.  
Setting Range: *1-100*  
Factory setting: *50*

### Time Date Tab



- **Date Format:** allows you to select the date format.  
Options: *MM/DD/YY or DD/MM/YY*  
Factory setting: *MM/DD/YY*
- **Clock Format:** allows you to select the time format.  
Options: *12 hour or 24 hour*  
Factory setting: *24 hour*

## Communications Menu

Each tab under the Communications menu is discussed below. Refer to [Table 6 on page 27](#) for the menu structure.

### Remote Enable Tab

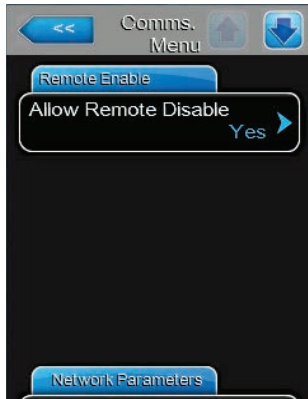

- **Allow Remote Disable:** allows you select whether steam production by the humidifier can be remotely disabled via the BMS.  
Options: Yes – remote disable permitted.  
No – remote disable not permitted.  
Factory setting: Yes

### IP Parameters Tab



The following settings are used only for communications via the integrated BACnet IP protocol and web pages.

- **IP Type:** allows you to select how the IP address settings are assigned.  
Options: *DHCP* – automatically acquire network address settings. **Note:** After five unsuccessful attempts to acquire the address, the system will revert to Fixed assignment.  
*Fixed* – manually configure the network address and settings.  
Factory setting: *DHCP*

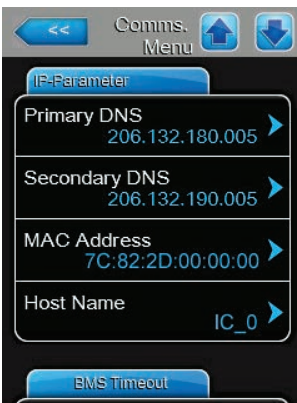

- **IP Address:** allows you to manually set the IP address. Set the IP address only if [IP Type](#) is set to "Fixed".
- **Subnet Mask:** allows you to manually set the IP subnet mask for the IP network. **Note:** Set the subnet mask only if [IP Type](#) is set to "Fixed".
- **Default Gateway:** allows you to manually set the default gateway for the IP network. **Note:** Set the default gateway only if [IP Type](#) is set to "Fixed".
  - **Primary DNS:** allows you to manually set the primary DNS (domain name server) for the IP address. **Note:** Set the primary DNS only if [IP Type](#) is set to "Fixed".
  - **Secondary DNS:** allows you to manually set the secondary DNS (domain name server) for the IP address. **Note:** Set the secondary DNS only if [IP Type](#) is set to "Fixed"
  - **MAC Address:** displays the MAC (media access control) address for the Condair GS humidifier.
  - **Host Name:** displays the host name for the Condair GS humidifier.

## BMS Timeout Tab

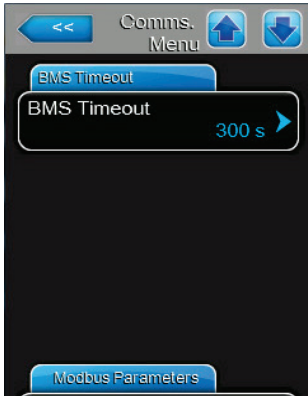

- **BMS Timeout:** allows you to set the maximum time the humidifier will wait without any communications from the BMS network before a timeout warning is generated.  
Setting range: 1-300 s  
Factory setting: 300 s

## Modbus Parameters Tab

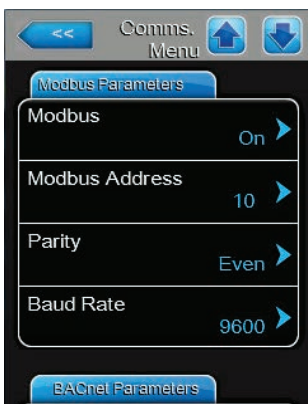

- **Modbus:** allows you to enable or disable the Modbus communications protocol. Enabling or disabling Modbus always requires a power cycle of the unit.  
Options: Off, Modbus/RTU, Modbus/TCP  
Factory setting: Modbus/RTU

The following settings appear only if [Modbus](#) is enabled.

- **Modbus Address:** allows you to set the Modbus address of the humidifier on the network.  
Setting range: 1-247  
Factory setting: 10
- **Parity:** allows you to set the parity bit for the data transfer.  
Options: None, Even or Odd  
Factory setting: Even
- **Baudrate:** allows you to set the baudrate for the data transfer.  
Options: 110, 300, 600, 1200, 2400, 4800, 9600, 19200, 38400, 57600, 76800 or 115200  
Factory setting: 9600

## BACnet Parameters Tab



- **BACnet:** allows you to enable or disable the BACnet communications protocol. Enabling or disabling BACnet always requires a power cycle of the unit.  
Options: *BACnet/IP* – enables BACnet/IP over the RJ45 (Ethernet) interface.  
*MSTP* – enables BACnet MSTP over the RS485 interface. **Note:** The Condair GS humidifier is a slave-only BACnet MSTP device.  
*Off* – disables BACnet communications protocol.  
Factory setting: Off

## BACnet Parameters Tab (continued)

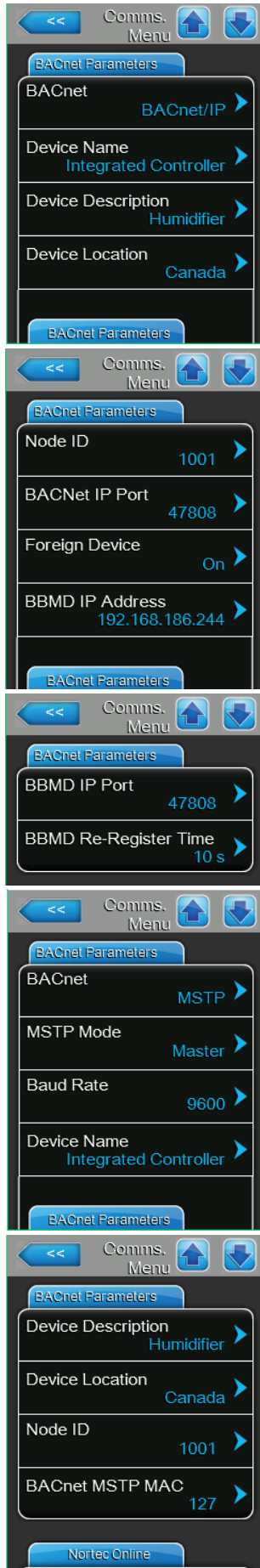

The following settings appear only if [BACnet](#) is set to "BACnet/IP" or "MSTP".

- **Device Name:** allows you to assign a name to the humidifier for communications over the BACnet/IP protocol.
- **MSTP Mode:** Master or Slave  
When set to BACnet MSTP the Condair GS humidifier communicates as a BACnet slave only. BACnet master functionality requires installation of optional hardware.
- **Baud Rate:** Determines the speed of data transmission for communication on the Modbus network. The higher the value, the more its per second is transferred.
- **Device Description:** allows you to enter a description for the humidifier.
- **Device Location:** allows you to enter the location of the humidifier.
- **Node ID:** allows you to assign a node ID to the humidifier for communications over the BACnet/IP protocol.  
Setting range: 1-9999999  
Factory setting: 1001
- **BACnet IP Port:** allows you to assign a IP port number for the humidifier.  
Setting range: 1-65535  
Factory setting: 47808
- **BACnet MSTP MAC:** allows you to assign a MSTP MAC address for the humidifier.  
Setting range: 128-254  
Factory setting: 128
- **Foreign Device:** When Foreign Device is ON, BBMD IP Port, IP Address, and Re-Register Time appears.  
A foreign device will need to connect to the BACnet network. When a foreign device is connected, it has to communicate through a BBMD (such as an IP router) first. You will need the IP address, IP port, and re-register time.
- **BBMD IP Address:** Appears when Foreign Device is ON. Enter the IP address of the foreign device.
- **BBMD IP Port:** Appears when Foreign Device is ON.  
Factory setting: 47808
- **BBMD Re-Register Time:** Appears when Foreign Device is ON. When a foreign device is connected, a client (external is 'registered' for a fixed amount of time. To conserve 'space' in the foreign device, the registered device is removed if the device fails to re-register within the preset time.  
Factory setting: 10 s

## Remote Fault Board Tab

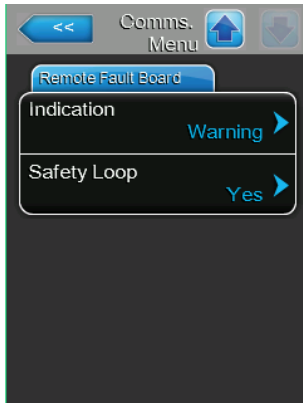

- **Indication:** Alters how system warnings are generated on the remote fault board. If warning is selected the RFB will activate the service output on any system warning, including system notifications prior to completing automated corrective actions (ex. fill time-out). If Service is selected, the RFB will activate the service output only for service warnings.  
Options: *Warning, Service*  
Factory setting: *Warning*
- **Safety Loop:** when enabled the remote fault board will activate the service relay upon the security loop opening  
Options: *Yes, No*  
Factory setting: *No*

## 4.2.6.2 Service Menu

The Service menu lets you enter the startup code, reset the service reminder after performing scheduled maintenance, access the fault and maintenance history lists and perform diagnostics. Refer to [Figure 7 on page 27](#). Refer to [Table 6 on page 27](#) for the menu structure.

Each tab under the Service menu is discussed below. The Service menu can also be accessed from the maintenance and fault status area on the Home screen – refer to [Figure 6 on page 19](#).

### Humidifier Service Tab



- **Drain Tank:** allows you to drain the tank. It can take up to 1 hour to drain the tank using this function. A warning message is displayed asking you to confirm if you want to proceed with draining the tank. Refer to ["Manually Initiate Tank Draining" on page 52](#) for detailed instructions.
- **Clean Tank:** allows you to flush the tank in preparation for maintenance. It can take up to 2 hours to flush and drain the tank using this function. A warning message is displayed asking you to confirm if you want to proceed.



#### WARNING!

**Risk of severe burns from contact with hot steam vapours or hot water!**

**DO NOT** remove the tank cover until the unit has cooled down to a safe temperature and the tank is fully empty.

- **Service Interval:** allows you to set the time interval between scheduled maintenance on the unit.  
Setting range: 0-3999 h  
Factory setting: 500 h
- **Reset Service Reminder:** allows you to reset the service reminder message after performing scheduled maintenance on the unit. A warning message is displayed asking you to confirm the reset.



#### CAUTION!

**Risk of damage to equipment!**

**DO NOT** reset the service reminder unless the scheduled maintenance has been performed.

### General Service Tab

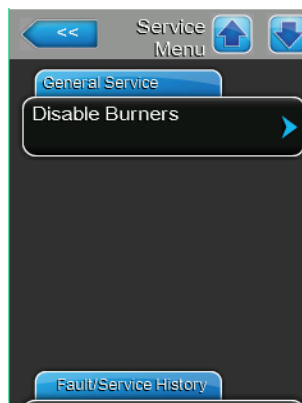

- **Disable Burners:** allows you to view the Burners tab (not shown) so you can enable or disable individual burners in the unit.
- **Burner "n":** allows you to enable or disable the individual burner; where "n" represents the burner number (1 to 4, depending on the number of blowers in the unit).  
Options: On or Off  
Factory setting: On

## Fault/Service History Tab

**Note:** Make sure that [Date](#) and [Time](#) are set correctly so that fault and maintenance history events can be correctly analyzed.



- **Fault History:** allows you to view the fault history list.
- **Service History:** allows you to view the service history list.
- **Reset Fault History:** (requires special service code - contact your Condair representative) allows you to reset the fault history. A warning message is displayed asking you to confirm the reset. All previously recorded fault history is erased.
- **Reset Service History:** (requires special service code - contact your Condair representative) allows you to reset the service history. A warning message is displayed asking you to confirm the reset. All previously recorded service history is erased.
- **Export History:** allows you to send your fault and service history to a USB device.

## Diagnostics Tab



- **Input Diagnostics:** allows you to access the Input Diagnostics menu and view the following tabs which show the current status of all inputs to the integrated controller, as well as calculated parameters.

### Controls Tab

- Digital RH/Demand Channel 1 and Channel 2
- FTBD
- Exhaust in Duct
- Safety Loop

### System Tab

- Over Temp
- Tank Temp
- Float Low
- Float Mid
- Float High
- A/P 1-4
- G/V 1-4

### Blowers Tab

- Blower RPM 1-4

### Counters Tab

- Primary Valve 1 and 2 Count
- Secondary Valve 1 and 2 Count
- Pulse Time On 1 and 2

- **Output Diagnostics:** (requires special service code - contact your Condair representative) allows you to access the Output Diagnostics menu to enable or disable various system components.  
**Note:** The diagnostic menu will only be displayed after you acknowledge the warning message that the humidifier will be placed in standby mode.

**Output Diagnostics Tab**

- Blower Relay
- Secondary Fill Valve 1 and 2
- Freeze Valve
- Drain Water Cool Valve
- Drain Pump
- Blower PWM
- Primary Fill Valve 1 and 2
- Fan On
- Blower RPM 1 and 2
- Ignition Mod 1-4

- **Relay Diagnostics:** allows you to access the Relay Diagnostics menu to enable or disable the relays on the remote fault board.  
**Note:** The diagnostic menu will only be displayed after you acknowledge the warning message that the humidifier will be placed in standby mode.

**Remote Fault Board Tab**

- Running
- Service
- Fault

**4.2.6.3 Setpoint**



- **Setpoint:** the desired conditions (RH setpoint) that the humidifier must try to maintain. This setting only appears when the Control Mode CH 1 is set to RH P or RH PI. Refer to [Page 32](#).

#### 4.2.6.4 Administrator Menu

The Administrator menu lets you enable and disable password control, or install updates for the control software. Refer to [Table 6 on page 27](#) for the menu structure.

Each tab under the Administrator menu is discussed below.

##### Password Setting Tab



- **Setpoint Password:** allows you to enable or disable password control to modify setpoint values when the humidifier is configured to operate on internal RH(P) or RH(PI) control.  
Options:                    Yes – requires password to modify setpoint values.  
                                     No – requires no password to modify setpoint values.  
Factory setting:        Yes
- **Main Menu Password:** allows you to enable or disable password control to access the Main menu.  
Options:                    Yes – requires password to access the Main menu.  
                                     No – requires no password to access the Main menu.  
Factory setting:        Yes

##### Software Updates Tab



- **Software Update:** allows you to update the control software. A warning message is displayed asking you to confirm the software updating.  

---

**CAUTION!** The control software will be corrupted if updating is interrupted, which may render the humidifier unusable.  

---

Refer to ["Installing Software Updates" on page 69](#) for detailed instructions.
- **Driver A/B Update:** allows you to update the driver board firmware for steam cylinder A/B

## Software Settings Tab

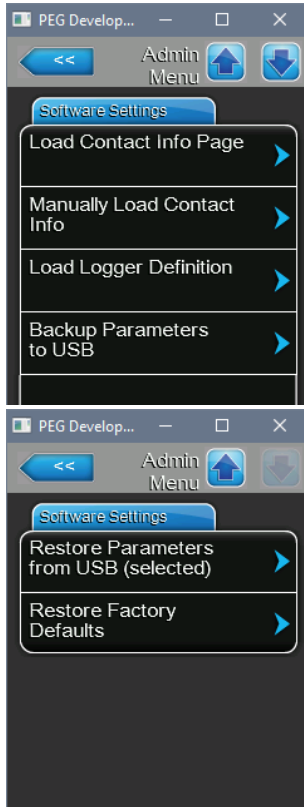

- **Load Contact Info Page:** allows you to automatically insert contact information (for technical support) in the unit, from a USB memory stick. This information is shown when selecting Help on the Home Screen. Information includes Company Name, Address, Telephone Number, Email, and Website. Please contact your Condair representative for assistance with this.
- **Manually Load Contact Info:** allows you to manually enter the Company Name, Address, Telephone Number, Email, and Website, that will appear when the user selects Help from the Home Screen.
- **Load Logger Definition:** allows you to load a logger definition file from a USB drive to save data (CSV file) on the USB while the unit is functioning. A factory supplied access file is required to enable operation. The interval between recordings can be changed from the Engineering menu (see your Condair representative).
- **Backup Parameters to USB:** saves the current value of all persistent parameters from a certain integrated controller to USB (XML file).
- **Restore Parameters from USB (selected):** loads the persistent parameters (XML file) from USB to an integrated controller.
- **Restore Factory Defaults:** Return the GS software settings to values set at the factory.

## 4.3 Software Configuration

The Condair GS humidifier is shipped fully configured from the factory to suit your site-specific requirements, but this can be modified as needed. This section provides the necessary instructions to reconfigure the control software.

### 4.3.1 Configuring the Control Software

Perform the basic setup of the control software as follows, if necessary:

1. Make sure that all control wiring and jumpers are installed as described in "External Connections" in the Installation Manual.

2. Set up the following parameters:

[Source](#) – select the type of control signals to the humidifier ("Analog", "Modbus", "BACnet/IP", etc.).

Select "Analog" if a sensor/transducer signal or a demand signal from an external P/PI (proportional)/(proportional-integral) controller is wired directly to the humidifier. Otherwise, select an applicable digital communication protocol from the list. If your humidifier has the optional Lonworks or BACnet (BTL) module installed, select "Modbus".

[Control Channels](#) – select the number of control channels.

Select "Dual" if controlling the humidifier with a high limit and a control signal; otherwise set to "Single".

[Control Mode](#) – select the general control mode for the incoming control and high limit signal ("Demand", "RH P", "RH PI", or "On/Off").

Select "Demand" if the control signal is a demand signal from an external controller. Select "RH P" or "RH PI", as appropriate, if the control signal is from a sensor/transducer. Or select "On/Off" if the control signal is from an external On/Off humidistat.

Signal Type – select the signal type of the incoming control signal if [Control Mode](#) is set to "Demand", "RH P" or "RH PI", and signal [Source](#) is set to "Analog".

3. Select from "0-5V", "1-5V", "0-10V", "2-10V", "0-20V", "0-16V", "3.2-16V", "0-20mA", or "4-20mA", as appropriate for the external control device connected to Channel 1.

This concludes the basic setup of the control software.

### 4.3.2 Configuring for Multi-Unit Operation

Set up the control software for multi-unit operation as described below. A maximum of four humidifiers can be set up in a "Main-Extension" configuration using Condair's Linkup system to satisfy large humidification needs.

---

**IMPORTANT!** This procedure should only be used to control multiple humidifiers that are using the same control signal inputs from the same conditioned environment.

---

1. Make sure that all wiring and jumpers are installed, as described in "Connecting Multiple Units Using Linkup" in the Installation Manual.
2. Configure the main humidifier as described in ["Configuring the Control Software" on page 47](#).
3. Set [Linkup](#) to "Main" on the humidifier that will be designated as Main in the Linkup chain, and set up the following parameters on it:

[Linkup Units](#) – select the total number of humidifiers in the Linkup chain. For example, if there is one main unit and two extension units, then the total number of humidifier in the chain is 3.

[Linkup Type](#) – select the mode of operation of the humidifiers in the Linkup chain ("Series" or "Parallel").

[Sequence Rotation](#) – enable or disable the function that manages the starting order to balance the operating hours on each steam cylinder. Note: This setting is available only if [Linkup Type](#) is set to "Series".

[Sequence Interval](#) – set the time interval used by the control software to establish a new operating sequence to balance the operating hours on the steam cylinders in the Linkup chain.

[Linkup Timeout](#) – if required, change the maximum time limit that the units in the Linkup chain can operate without a connection to each other before they generate a Linkup Timeout warning message.

[Zero Out](#) – if required, set the percentage value of the system demand signal at which the unit is switched on.

[Full Out](#) – if required, set the percentage value of the system demand signal at which the unit achieves 100% demand.

4. Set [Linkup](#) in each extension humidifier as Ext1, Ext2, ...

**Note:** Each extension unit must be a unique extension number.

The humidifiers in the Linkup chain are now set up to generate steam upon humidity demand.

# 5 Operation

## 5.1 General

### Personnel Qualifications

The Condair GS humidifier must only be operated by personnel who are adequately qualified, well trained and are authorized by the customer.

### Safety

Observe all safety precautions described in ["For Your Safety" on page 8](#).

## 5.2 Operating Procedures

### 5.2.1 Filling the System

Fill the Condair GS humidifier as follows. The control software also performs the float test to ensure that the fill system, the water level controls and the drain pump(s) are functioning properly.

1. Close the manual gas shutoff valve in the supply line.
2. Open the shutoff valve in the water supply line.
3. Set the On/Off button on the humidifier to the On position.

The control software then energizes the dual fill valve(s) and starts to fill the tank. When the water in the float chamber(s) reaches the L1 level (red LED), the control software runs a series of tests on the fill and drain system as described in ["Water Management" on page 15](#). On successful completion of the tests, the float chamber is filled to the L3 level (green LED), and the humidifier goes into standby mode. This process can take approximately 10-30 minutes depending on the size of the unit.

4. Set the On/Off button to the Off position, and perform the ["Ignition Safety Shutoff Test"](#) described below.

### 5.2.2 Ignition Safety Shutoff Test

Perform the ignition safety shutoff test as described below:

1. Check that the manual gas shutoff valve in the supply line is still closed.
2. Make sure that the contacts of all devices connected to the external security loop are closed.
3. Set the On/Off button to the On position. The control software runs a series of tests on the fill and drain system, and on successful completion the humidifier goes into standby mode.
4. Set the demand signal to the humidifier from the building management system (BMS) or humidistat at 100%.

The control software energizes the blower(s) to initiate the combustion sequence. The blower(s) run at full capacity to purge the system. The control software then verifies the proper functioning of the safety systems and the blowers as described in ["Combustion" on page 15](#).

After the safety systems check is completed successfully, the ignition control module(s) is energized. The spark-igniter(s) attempts to fire up three times to ignite the gas-air mixture. Since the gas supply is shut off, no flame is detected by the flame sensor(s) and the gas valve(s) is de-energized. The red LED in the ignition control module(s) flashes to indicate a safety lockout. The warning message [Ignition Fail](#) also appears on the touchscreen display after a short delay.

**Note:** On units with multiple burners, each burner attempts to ignite in sequence. Hence, it is important to wait for all burners to complete its cycle.

The ignition safety shutoff test is successful when no gas flows to the burner(s) when the manual gas shutoff valve is closed.

After all burners have failed to ignite, the fault message "No Burners Available" will appear on the display. The blowers will perform a post-purge and then shut off.

5. Power cycle the humidifier to reset the fault condition.
6. Open the manual gas shutoff valve.

### 5.2.3 Starting the Humidifier

Start the humidifier as follows:

1. Make sure that the tank in the humidifier is filled with water – refer to ["Filling the System" on page 49](#).
2. Make sure that the ignition safety shutdown test is completed – refer to ["Ignition Safety Shutoff Test" on page 49](#).
3. Check that the shutoff valve in the water supply line is open.
4. Check that the manual gas shutoff valve in the supply line is open
5. On the CS model, make sure that the condensate trap inside the unit is primed properly.
6. Check that the contacts of all devices connected to the external security loop are closed.
7. Make sure that all access panels on the humidifier are installed and fastened securely.
8. Set the On/Off button on the humidifier to the On position.

The control software then energizes the dual fill valve(s) and starts to fill the tank. It then performs a series of tests to verify the function of the floats, the dual fill valves and the drain pump – refer to ["Water Management" on page 15](#). Upon successful completion of the tests, the combustion sequence starts – refer to ["Combustion" on page 15](#).

Depending on the system demand, the blower(s) runs faster or slower to control the input of the burner(s). The generated heat turns the water in the tank to steam, which is then delivered to the distribution system.

As the water level in the tank is reduced due to evaporation, the dual fill valves pulse to maintain water at the proper level. In the CS model only, cold fill water passes through the secondary heat-exchanger. Here, heat from the exhaust warms up the cold fill water entering the tank.

When the humidity demand has been satisfied (demand drops below the minimum %), the gas valve(s) is de-energized. The blower(s) then performs a post-purge of the combustion chamber(s), and then shuts off.

If there is no humidity demand, the humidifier goes into standby mode to await the next humidity demand signal.

## 5.2.4 Remote Monitoring

The Condair GS humidifier can be monitored remotely through the remote fault board wired to a remote monitoring system. [Table 7](#) describes the function of each relay when triggered.

Table 7: Remote Relay Function

Remote Relay	Description
Error	The humidifier is stopped due to a fault condition, or may be operable only for a limited period of time.
Service/Warning	Depending on the software configuration, indicates that a service warning or a system warning/notification is active.
Unit On	The humidifier has power, and the On/Off switch is in the On position.

The Condair GS humidifier can also be monitored remotely from a laptop or desktop computer using the ethernet port on the integrated control board. Contact your Condair representative for assistance.

## 5.2.5 Inspections During Operation

Perform regular inspection of the Condair GS humidifier and the humidification system when it is in operation. Inspect the following:

- Check the gas connection for any leaks.
- Check the water, drain and steam connections for any leakages.
- If applicable, check the humidifier and other system components have not shifted from their mountings, and are fastened securely.
- Check for leaks in the exhaust vent. Check that there are no obstructions anywhere in the exhaust vent, including the exhaust terminal.
- Keep the area around the air intake in the unit clear of all obstructions. If an air intake vent is used, check for leaks and obstructions in the vent, including the intake terminal.
- Check the area around the unit is clear of all insulating and combustible materials.
- Visually check the electrical wiring for any damage.
- Check the Home screen on the humidifier for service or system warning messages.

If any irregularities (leakages, fault messages or damaged components) are found, shut down the Condair GS humidifier before performing service – refer to ["Shutting Down" on page 53](#). Contact your Condair representative if assistance is required.

## 5.2.6 Manually Initiate Tank Draining

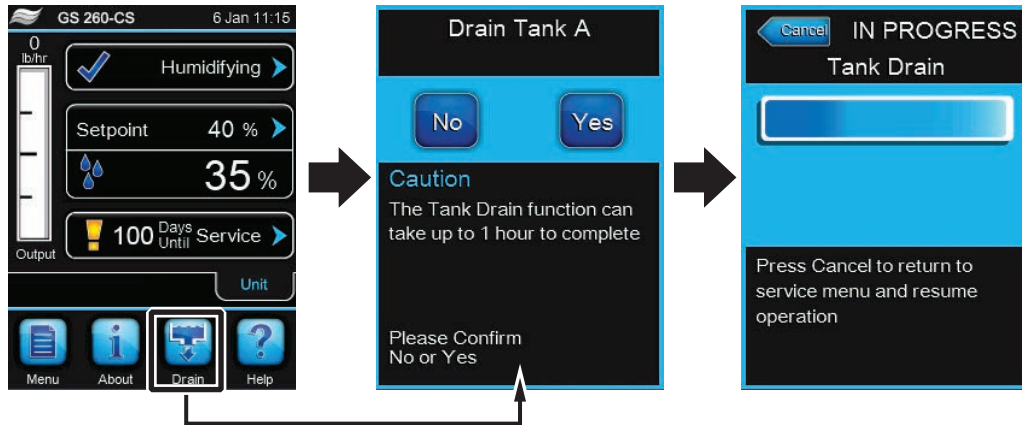



Figure 8: Drain Screens

During periods of inactivity, such as off-season or periods of low demand, drain the water from the tank. To drain the tank in the Condair GS humidifier, manually initiate draining as follows. Refer to [Figure 8](#).

1. Select the <Drain> button on the Home screen. If more than one humidifier is connected in a Linkup chain, select the appropriate tank, then press the check mark.
2. Select the <Yes> button on the confirmation screen. If humidification is in progress, it is interrupted and the drain pump(s) empties the tank. A progress bar shows the status of the drain cycle.

Select the <Cancel> button at any time to interrupt the drain cycle. If the drain cycle is interrupted before it is completed, open the manual drain valve and verify that there is still water in the tank. Close the manual drain valve, then select the <No> button on the next screen to confirm that the tank has not been emptied fully.

**Note:** If necessary, set the On/Off switch to the Off position at the end of the drain cycle to prevent the humidifier from filling the tank again.

 **WARNING!**  
Risk of severe burns from contact with hot surfaces, steam or hot water!

**The tank may contain steam or hot water. Contact with the hot surfaces, steam vapours or hot water can result in severe burns.**

**Prevention:** Never open the tank until it has been fully drained, and the unit has cooled down to a safe temperature. Never use the manual drain valve until the unit has cooled down. Use the manual drain valve to verify that the tank is empty before removing the tank cover.

**Note:** If the control software/drain valve(s) does not function properly, wait for the unit to cool down then open the manual drain valve and empty the tank. Failure to do so may damage drain lines that are not rated to handle hot water at up to 212 °F (100 °C). Close the drain valve after emptying the tank.

## 5.2.7 Full Tank Blowdown

The control software in the Condair GS humidifier performs a full tank blowdown to reduce the amount of dissolved minerals accumulated inside the tank. The Drain Cool function in the control software permits drain water cooling whenever the drain pump runs. Make sure that the function is enabled if drain cooling is required. The frequency of the blowdown can be set in the control software.

In addition to the software-controlled full tank blowdown, a separate 24 VAC signal connected to pins "1" and "8" in the low voltage terminal strip can also initiate a full tank blowdown. When a full tank blowdown is initiated, the tank is drained fully then refilled. Make sure the Drain Cool function is enabled if drain cooling is required.

## 5.2.8 Shutting Down



**DANGER!**  
Risk of electric shock!

**The control cabinet in the Condair GS humidifier has live voltage. Turning off the unit at the On/Off switch does not shut off power to the control cabinet, which is still live. Touching live parts may cause severe injury or even death.**

**Prevention:** Before performing any work inside the humidifier or with the humidification system, shut down the humidifier properly as described below.

Shut down the Condair GS humidifier as follows for maintenance, or at the end of the season:

1. Set the demand signal to the humidifier from the BMS or the humidistat at 0%. Then allow the burner(s) to shut off and the blower(s) to perform a post-purge of the combustion chamber(s).
2. Manually initiate draining of the tank. Refer to ["Manually Initiate Tank Draining" on page 52](#).  
**Note:** If the control software/drain valve(s) does not function properly, wait for the unit to cool down before using the manual drain valve to empty the tank. Failure to do so may damage drain lines that are not rated to handle water at up to 212 °F (100 °C). Close the drain valve after emptying the tank.
3. Make a note of any fault code displayed on the Home screen.  
**Note:** At the end of the season, report the fault history to a Condair-certified technician. Select Service > Fault/Service History tab to access the fault history.
4. Set the On/Off button to the Off position.
5. Close the manual gas shutoff valve in the supply line.
6. Close the shutoff valve in the water supply line.
7. Disconnect the power supply to the humidifier at the external disconnect switch. To prevent accidental power-up, lockout and tag out according to the established safety practices at your facility.
8. Wait for the unit to cool down to a safe temperature before performing any maintenance inside the plumbing cabinet.

## 5.2.9 Restarting After Shutdown

Restart the Condaire GS humidifier as follows after it has been shut down for maintenance or at the start of the season:

1. Examine the humidifier and other system components for damage. Do not use the appliance if any part of the humidifier has been under water. Call a qualified service technician to inspect and replace any part of the control system or gas control that has been under water.
2. Check for loose or damaged electrical connections, and repair if necessary.
3. If applicable, make sure that the humidifier and its components have not shifted from their mountings, and are fastened securely.
4. Make sure that all condensate traps in the exhaust and steam lines are primed properly.
5. Clean any build-up of dirt around the control cabinet, the area around the burner(s). Clean the area around the air intake inlet to prevent contaminants from being drawn into the combustion chamber.
6. Clean the air intake terminal, if the humidifier is connected to the exterior.
7. Make sure that all access panels on the humidifier are installed and fastened securely. Refer to ["Removal and Installation of Access Panels" on page 60](#).
8. Remove the lock and tag from the external disconnect switch, and restore power to the humidifier.
9. Open the water and gas supply to the unit.
10. Start up the humidifier as described in ["Starting the Humidifier" on page 50](#).

# 6 Maintenance

---

## 6.1 General

To ensure proper performance and long operating life of the Condaire GS humidifier, Condaire recommends inspection of the appliance and installation at least once a year by a qualified service person. The amount and type of maintenance required is generally dependent on how much the humidifier operates. The Condaire GS humidifier monitors the amount of steam produced over time and will indicate when service is required. All units come with a default service interval of 1000 hours, which can be adjusted in the control software.

The combustion air blower motors are permanently lubricated and do not require lubrication.

The gas valves in the Condaire GS humidifier are negative-pressure-regulated valves. The valves are factory-set for the correct gas type. The valve setting listed on the product rating plate is shown relative to atmosphere – this setting will always remain constant. Contact the factory if adjustment is needed.

---

**IMPORTANT!** Tampering with the gas valve, without the express consent of Condaire, will void the warranty.

---

In general, the burners do not require adjustment or servicing. The combustion chamber and heat-exchanger tubes are all fabricated from stainless steel, and do not require internal cleaning.

The exhaust vent connected to the Condaire GS humidifier does not require cleaning, but needs to be inspected regularly for leaks, blockages, sagging and proper condensate removal.

For proper and safe operation of the unit, the area around the air intake in the unit must be kept clear of all obstructions. If an air intake vent is used, it must be inspected for leaks and obstructions (including the intake terminal).

Refer to ["Mandatory Maintenance Schedule" on page 56](#) for other maintenance requirements. Also perform regular inspections when the unit is operating – refer to ["Inspections During Operation" on page 51](#).

---

**IMPORTANT!** Damage caused by use of non-approved parts is not covered by warranty. Use only original Condaire replacement parts.

---

### Personnel Qualifications

Maintenance on the Condaire GS humidifier must only be performed by well qualified and properly trained personnel authorized by the customer. It is the customer's responsibility to verify qualifications of the personnel.

### Safety

Make sure that the Condaire GS humidifier is shut down properly as described in ["Shutting Down" on page 53](#), and observe all safety precautions described in ["For Your Safety" on page 8](#) before performing any maintenance on the humidifier.

## 6.2 Mandatory Maintenance Schedule

[Table 8](#) lists the mandatory maintenance schedule for the Condair GS humidifier.

*Table 8: Mandatory Maintenance Schedule*

Task	30 Days After Initial Start-up	Mid-season	End of Season (2000 hrs)	Maintenance
Inspect drainage.	X	X	X	Perform a visual check of the drainage system, including the air gap funnel and drainage into the building drain. Initiate a manual drain (refer to <a href="#">"Manually Initiate Tank Draining" on page 52</a> ), and visually check that water flows freely through the drain.
Perform water analysis.	–	X	X	Perform a water analysis on a semi-annual basis to ensure optimal performance. Refer to <a href="#">"Management of Scale and Chloride Levels" on page 58</a> .
Inspect tank, primary heat-exchanger coils and drain fitting for scale build-up.	X	X	X	Adjust <a href="#">Blowdown Rate</a> and <a href="#">FTBD Interval</a> , as necessary, to reduce scale build-up. Inspect the inside of the tank, and make sure that scale build-up does not exceed 2 in (50 mm). De-scale as required. Refer to <a href="#">"Cleaning the Tank" on page 62</a> .
Inspect secondary heat-exchanger (CS model only) for blockage.	–	X	X	Inspect water flow through the secondary heat-exchanger and make sure there is not blockage. Clean, if necessary – refer to <a href="#">"Cleaning the Secondary Heat-exchanger" on page 63</a> . Inspect the condensate trap connected to the secondary heat-exchanger for blockage. Flush and prime the condensate trap, if necessary – refer to <a href="#">"Cleaning the Secondary Heat-exchanger" on page 63</a> .
Inspect sacrificial anode in the tank.	–	–	X	Inspect the anode for severe corrosion or scale build-up. Scrape off excess scale – refer to <a href="#">"Cleaning the Tank" on page 62</a> .
Clean the float chamber.	X	X	X	Make sure that the floats move freely. Clean the float chamber – refer to <a href="#">"Cleaning the Float Chamber" on page 64</a> .
Inspect the hoses, fill valve and drain pump for blockage.	–	X	X	Check the fill and drain hoses for blockage. Clean the inside of the hoses – refer to <a href="#">"Cleaning Hoses, Dual Fill Valves and Drain Pump" on page 65</a> . Clean the strainer in the dual fill valves – refer to <a href="#">"Cleaning Hoses, Dual Fill Valves and Drain Pump" on page 65</a> . Clean the drain pump – refer to <a href="#">"Cleaning Hoses, Dual Fill Valves and Drain Pump" on page 65</a> .
Remove dust build-up on the blower housing.	–	X	X	Use an air gun to remove dust accumulation on the blower housing.
Inspect the spark-igniter for oxidation.	–	–	X	Clean the spark-igniter – refer to <a href="#">"Cleaning the Burner Assembly" on page 67</a> for details.
Inspect the exhaust vent and terminal.	X	X	X	Check that there are no leaks in the exhaust vent, and it is not damaged or corroded excessively. Check the vent is secured properly and has the proper slope. Make sure there is no blockage in the exhaust vent including the exhaust terminal. When operating in a stable state, make sure that flue temperature is 275-300 °F (135-149 °C) for the standard-efficiency model. Flue temperature should be 120-140 °F (49-60 °C) for the CS model.
Inspect air intake vent and terminal.	–	X	X	Check the air intake vent for leaks, if used. Make sure there is no blockage in the air intake terminal, if used. Clean the screen on the elbow at the intake air inlet.
Inspect high limit switch and sensor.	X	X	X	Visually check that the thermocouple is attached to the exhaust vent, and the thermocouple wires are connected properly to the switch.

Task	30 Days After Initial Start-up	Mid-season	End of Season (2000 hrs)	Maintenance
Inspect condensate collection system.	X	X	X	Check for leaks or blockages in the condensate lines throughout the steam line and exhaust vent (if applicable).
				Make sure that the condensate traps are primed.
				If a condensate neutralizer is installed, follow recommendations of the device manufacturer.
Inspect the mounting of the unit.	–	–	X	Check the mounting surface on which the unit is installed is stable, and the unit is secured properly to the mounting surface.
Inspect overall condition of the unit.	–	–	X	Check the unit for obvious signs of deterioration.
Inspect high temperature elbows and hose cuffs on the exhaust connection(s)	–	–	X	Check the unit for obvious signs of deterioration. Check for leaks and cracks.

Also perform regular inspections when the unit is operating – refer to "[Inspections During Operation](#)" on page 51.

### 6.3 List of Consumables

[Table 9](#) shows the list of consumable items for the Condair GS humidifier.

Table 9: Consumables

Consumable Item	Replace	Part Number
High temperature silicone exhaust gas hoses and elbows	After 4 seasons (8000 hours) Note: Stainless steel elbow - does not need replacement.	Refer to the Spare Parts List for kit part numbers.
Spark igniter	After 3 seasons (6000 hours)	
Tank door gasket	After each cleaning	
Sacrificial anode	When needed	
All other gaskets	When removed	

Condair GS units come with a sacrificial anode installed as standard. The anode is a crucial component in protecting the tank and heat exchanger from corrosion. Made from a more reactive metal, the anode is installed on the door and corrodes instead of the tank or heat exchanger, thereby extending their lifespan. This process, known as cathodic protection, ensures that the anode sacrifices itself to prevent more critical components from deteriorating. Regular inspection and replacement of the sacrificial anode are essential to maintain effective protection.

## 6.4 Management of Scale and Chloride Levels

As the humidifier produces steam, minerals dissolved in the water begin to concentrate in the tank over time. The amount of dissolved minerals and the chloride levels need to be carefully controlled so they do not affect the efficiency and service life of components. Hardness of water may cause foaming and contribute to scale build-up in the humidifier tank and float chamber, and chlorides increase the risk of stress corrosion cracking in stainless steel components of the humidifier. All of these contribute to reduced efficiency, and increased amount of service and related maintenance costs.

---

**IMPORTANT!** Component failures due to water quality outside the recommended ranges (refer to [Table 10 on page 58](#)) are not covered by warranty.

---

The Condair GS humidifier periodically drains water from the tank to reduce the concentration of dissolved minerals that accumulate during long-term operation. This is achieved in two ways – through a partial blowdown and a full tank blowdown (FTBD).

In a partial blowdown, a certain amount of water (determined by the Blowdown Rate setting) is drained from the tank and replaced with fresh water, thus lowering the concentration levels. In a FTBD, the entire tank is drained when a certain number of weighted hours (determined by the FTBD Interval setting) have elapsed, then refilled with fresh water. Weighted hours is defined as the hours equivalent to a unit operating at 100% output.

The humidifier is shipped with a default Blowdown Rate of 25% for the partial blowdown, and FTBD Interval of 100 hours for FTBD. These settings ensure that concentration of dissolved minerals is minimized for all water conditions. However, they can be adjusted in the control software once water conditions are known for your site – refer to ["Adjusting Blowdown Settings" on page 59](#).

In addition to the software-controlled FTBD, a separate 24 VAC signal connected to pins "1" and "8" in the low voltage terminal strip can also be used to initiate a full tank blowdown at any time.

### Water Quality

The water quality requirements for the Condair GS humidifier are shown in [Table 10](#). Do-it-yourself kits are available to test hardness in the feed water. You can also contact your local municipality for a water quality report, or order a Condair water test kit.

Table 10: Water Quality Requirements

Water Type	Hardness gpg (PPM)	pH	Chloride PPM *	Conductivity (µS/cm)	Silica (PPM)
Potable	0 - 20.42 (0 - 350)	6.5 - 8.5 **	0-40	0-1500	0-14
Treated	0-0.99 (0-17)	7.0 - 8.5 **	0-40	0-100	0-1

\* Damage caused by chloride corrosion is not covered by your Condair warranty.

\*\* If pH is >7.5 and the content of Sodium and/or sulfates are also high, the risk of foaming is increased.

## 6.4.1 Adjusting Blowdown Settings

Due to the wide range of water quality in different locations, it is important to adjust blowdown to suit the local water conditions. Use the following procedure to adjust the blowdown rate and FTBD interval for the water conditions at your site.

1. Test the quality of the feed water to determine the hardness and the chloride levels.
2. Then set the blowdown rate as follows:
  - a. Refer to [Table 11](#), and make a note of the recommended minimum blowdown rate for the hardness level of the feed water.
  - b. Then refer to [Table 12 on page 59](#), and make a note of the recommended minimum blowdown rate for the chloride level in the feed water.
  - c. Set the Blowdown Rate on the Condair GS humidifier to the higher of the two noted values.
3. Set the FTBD interval as follows:
  - a. Refer to [Table 11](#), and make a note of the recommended maximum FTBD interval value for the hardness level of the feed water.
  - b. Refer to [Table 12 on page 59](#), and make a note of the recommended maximum FTBD interval value for the chloride level in the feed water.
  - c. Set the FTBD Interval on the humidifier to the lesser of the two noted values.
4. Once the base settings are set, monitor the water quality and maintenance history periodically, and adjust the settings accordingly.

Note: Factory tests have shown that increasing the blowdown rate reduces scale build-up, while reducing the FTBD interval reduces the chloride concentration levels in the tank. The adjusted settings should reflect a balance between reducing concentration levels and minimizing water usage.

*Table 11: Blowdown and FTBD Settings Related to Hardness of Water*

Feed Water Hardness gpg (PPM)	Recommended Minimum Blowdown Rate (%)	Recommended Maximum FTBD Interval (h)* Weighted hours
0-3.51 (0-60)	12	72
3.51-7.02 (60-120)	25	72
7.02-10.50 (120-180)	40	72
10.50-20.42 (180-350)	50	48
> 20.42 (350)	Not recommended for the humidifier without treatment of the water. Contact your local Condair representative.	

*Table 12: Blowdown and FTBD Settings Related to Chloride Levels*

Feed Water Chloride Levels (PPM)	Recommended Minimum Blowdown Rate (%)	Recommended Maximum FTBD Interval (h)* Weighted hours
5	12	72
5-15	25	72
15-25	45	48
25-40	50	24
> 40	Not recommended for the humidifier without treatment of the water. Contact your local Condair representative.	

## 6.5 Maintenance Procedures

### 6.5.1 Removal and Installation of Access Panels

#### Removal

1. Turn the captive screw at the bottom of the door panel (control cabinet/plumbing cabinet) counter-clockwise with a screwdriver.
2. Lift up the door panel slightly so that the top tabs clear the notches in the cabinet, then carefully swing the bottom of the panel up, and remove the panel.
3. To remove the left/right side panel, remove the screws and slide the panel towards the front of the unit, so the tabs in the side of the panel clear the notches in the fixed rear panel.

**Note:** The Condair GS 50/100 humidifier does not have a removable left side panel. To remove the right side panel, slide the panel towards the front of the humidifier until the tabs at the top rear and bottom rear of the panel clear the notches in the cabinet, then remove the panel.

#### Installation

1. Align and slide the side panel (left/right) towards the rear of the unit, so the tabs in the side of the panel engage with the notches in the fixed rear panel. Install the screws and fasten the panel securely.  
**Note:** To install the right side panel in the Condair GS 50/100 humidifier, align the tabs at the top rear and bottom rear of the panel with the notches in the cabinet, then slide the panel towards the rear of the unit until it is seated properly.
2. Position the door panel (control cabinet/plumbing cabinet) so that the two tabs in the top rear of the panel align with the notches in the cabinet.
3. Lower the door panel to seat the tabs in the notches, while ensuring that the tabs in the (left/right) side panel engage with the notches in the side of the door panel. Refer to the detail in the figure.
4. Make sure that the door panel fits flush on the front and the side. Turn the captive screw in the door panel clockwise to secure the door panel. Check that it is fastened securely.

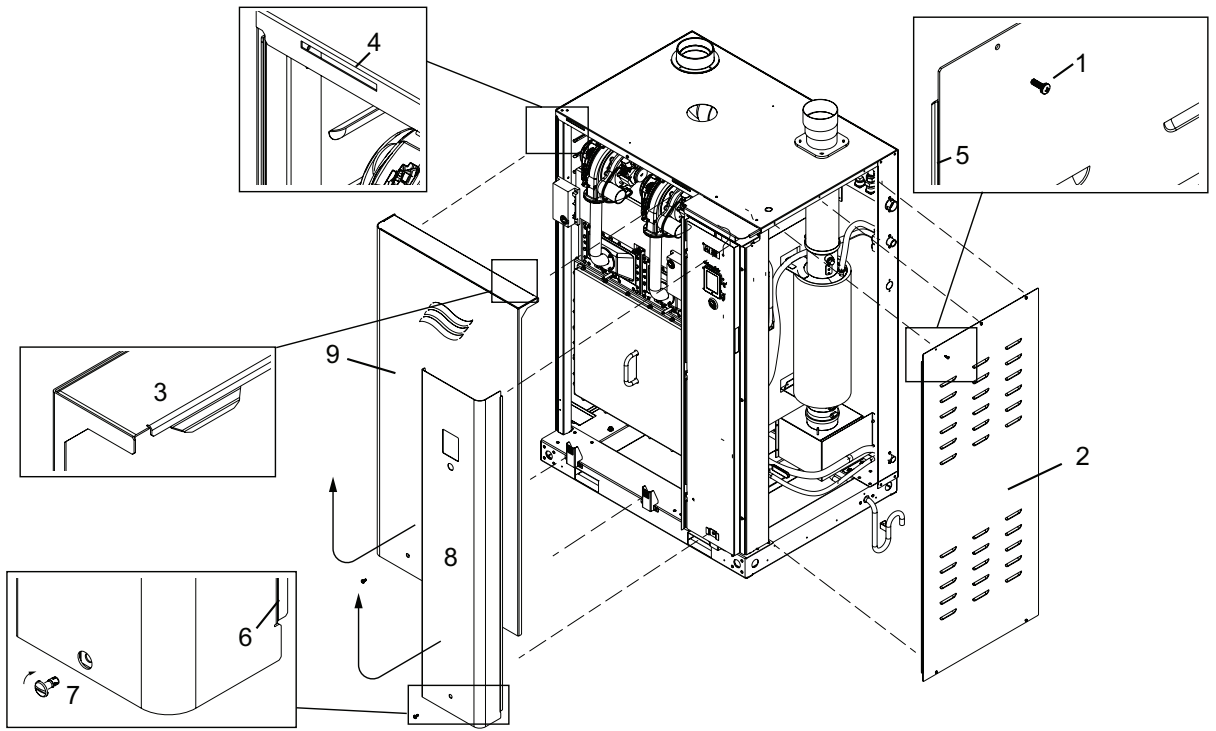

**Figure 9: Access Panels Removal and Installation (Condair GS 300 Shown)**

- |   |                     |   |                 |   |                              |
|---|---------------------|---|-----------------|---|------------------------------|
| 1 | Screw               | 4 | Notch, cabinet  | 7 | Screw, captive               |
| 2 | Panel, right side   | 5 | Tab, side panel | 8 | Door panel, control cabinet  |
| 3 | Top tab, door panel | 6 | Tab, door panel | 9 | Door panel, plumbing cabinet |

## 6.5.2 Cleaning the Tank

Clean the inside of the tank, the outside of the primary heat-exchanger coils and the drain fitting as follows. Refer to [Figure 10 on page 63](#). It is not necessary to remove the tank from the unit in order to clean it.

1. Use the Clean Tank function in the control software to flush and drain the tank, then shut down the humidifier as described in ["Shutting Down" on page 53](#).
2. Remove door panels – refer to ["Removal and Installation of Access Panels" on page 60](#) and remove all covers.
3. Inspect all fill hoses for scale build-up or blockages. Clean or replace where necessary.
4. Remove and discard the tank gasket (Condair does **NOT** recommend reusing the tank gasket).
5. Use a soft-bristled or plastic brush or scraper (not wire brush, not metal) to remove all scale build-up on the inside surfaces of the tank, all tank ports, the outside of the primary heat-exchanger coils, and inside of the drain fitting. Carefully remove any scale build-up on the surface of the temperature sensor. Vacuum out the tank. Flush water through the drain fitting to remove any remaining sediment.
6. Rinse the inside of the tank thoroughly with clean tap water.



**WARNING!**  
Risk of fire!

**DO NOT clean the sacrificial anode with any chemicals.** The anode can react with acids to create flammable hydrogen gas.

7. Inspect the sacrificial anode on the inside of the tank cover and use a soft-bristled brush (not wire brush) to remove scale build-up. Replace the anode, if necessary.
8. Install a new tank gasket and secure the tank cover to the tank. **Note:** The order of torquing the bolts for the tank cover are shown in the hexagonal symbols in [Figure 10](#). *Tighten bolts with your fingers and torque at the end of assembly.*

	M6 (top of door)	M6x22
Torque Values	70 in-lb (7.91 N·m)	70 in-lb (7.91 N·m)

9. Re-start the humidifier – refer to ["Restarting After Shutdown" on page 54](#). Check for leaks in the tank cover.

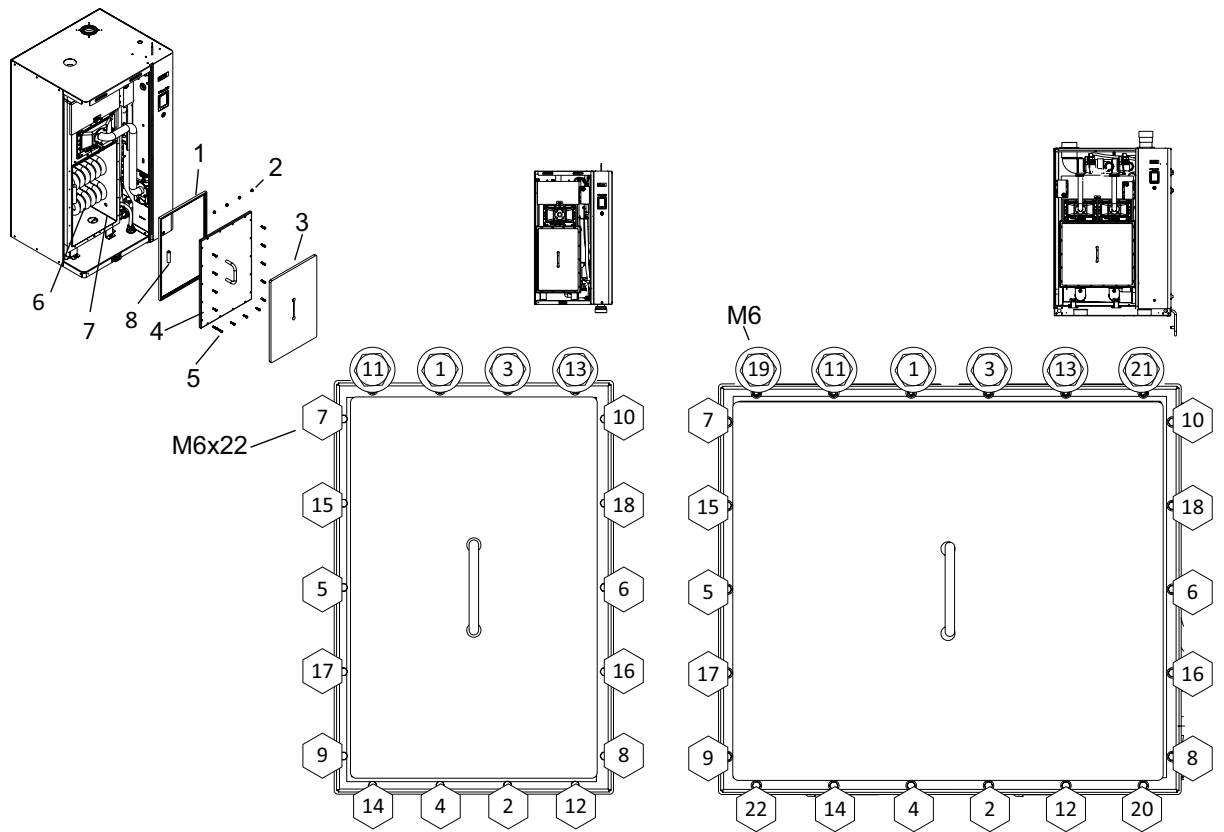

Figure 10: Tank Door Torque Sequence

- |                                |  |                     |
|--------------------------------|--|---------------------|
| 1 Gasket                       | 4 Tank door                                  | 7 Tank              |
| 2 M6 nut - 70 in-lb (7.91 N·m) | 5 M6x22 hex head screw - 70 in-lb (7.91 N·m) | 8 Sacrificial anode |
| 3 Insulation                   | 6 Heat exchanger coils                       |                     |

### 6.5.3 Cleaning the Secondary Heat-exchanger

Clean the secondary heat-exchanger and condensate trap (CS/NX model only) as follows. Refer to [Figure 11 on page 64](#).

1. Drain the tank, and shut down the humidifier as described in ["Shutting Down" on page 53](#).
2. Remove the side panel – refer to ["Removal and Installation of Access Panels" on page 60](#).
3. Disconnect the two water hoses from the secondary heat-exchanger.
4. Flush the inside of the secondary heat-exchanger with clean tap water.
5. Reconnect the water hoses. You may also refer to [Figure 13 on page 66](#).
6. Disconnect the condensate trap from the secondary heat-exchanger and flush out any scale build-up.
7. Reconnect the condensate trap, and prime the trap with water.
8. Re-start the humidifier – refer to ["Restarting After Shutdown" on page 54](#) and check for leaks.

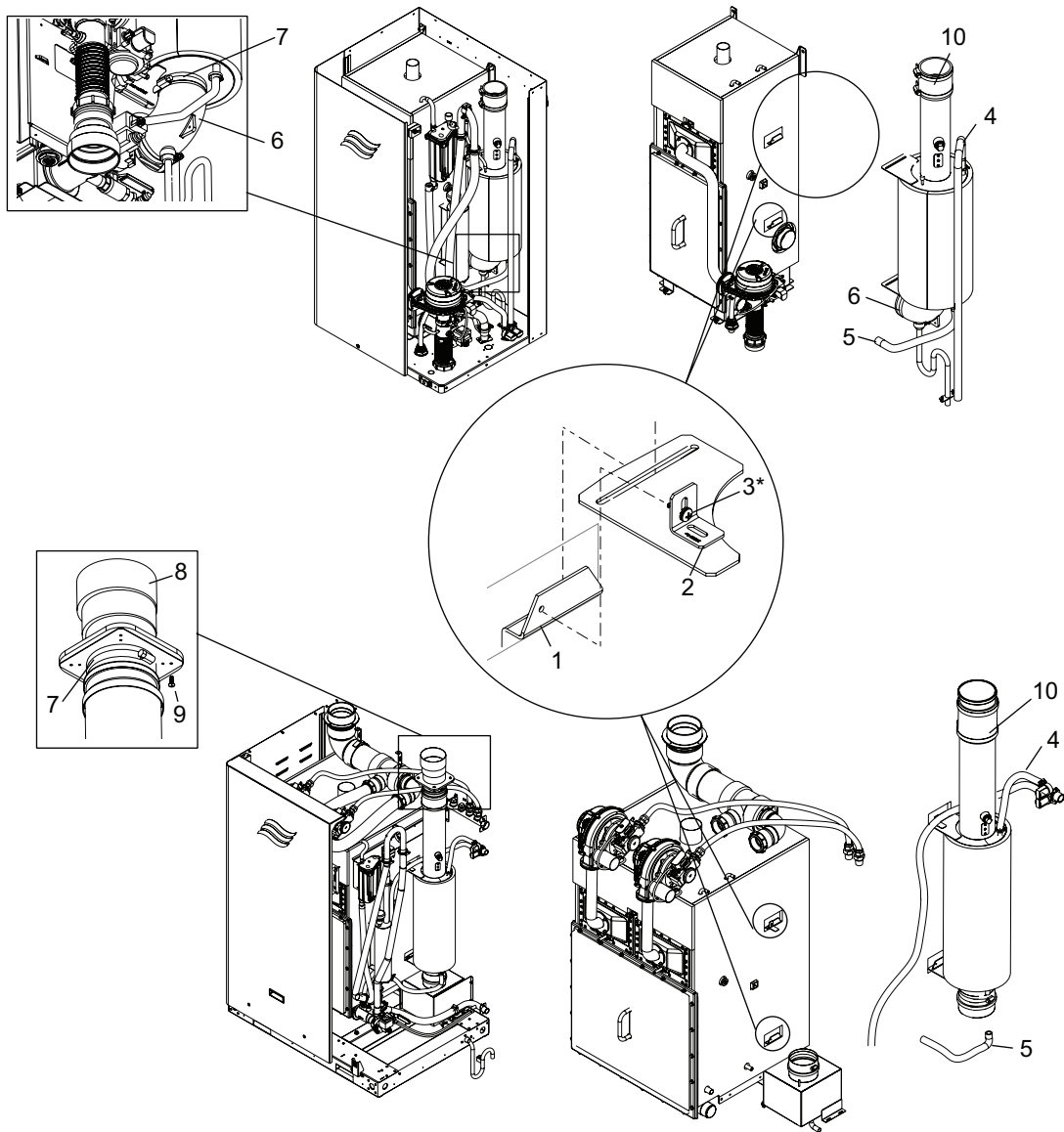

Figure 11: Cleaning Secondary Heat-exchanger -CS/NX Model Only (compact and double unit shown)

- |  |   |  |
|--|---|--|
| 1 Tank bracket   | 4 Hose, fill valve to top of heat-exchanger | 8 Exhaust adaptor                        |
| 2 Hanger bracket                                       | 5 Hose, heat-exchanger to tank.             | 9 Screw 8-32 x 0.5 in TA and star washer |
| 3 * L-bracket (for the top of the heat-exchanger only) | 6 Silicone fitting elbow                    | 10 Silicone exhaust tube                 |
| 7 Hose clamp   |   |  |

### 6.5.4 Cleaning the Float Chamber

Clean the float chamber in the fill box as follows. Refer to [Figure 12 on page 65](#).

1. Shut down the humidifier as described in ["Shutting Down" on page 53](#) and remove the side panel – refer to ["Removal and Installation of Access Panels" on page 60](#).
2. Remove hoses from the float chamber, and remove the float chamber by pulling on the rear tab and lifting the float chamber upwards.
3. Open the float chamber and carefully remove the two floats. Make a note of the orientation of the floats.
4. Use a soft-bristled brush (not wire brush) to remove all scale build-up on the floats, the inside of the float sleeve and the float chamber. Rinse with clean tap water.
5. Visually check each float for cracks or other damage. Place the two floats in a container filled with clean water, and check that they both have equal buoyancy. If necessary, replace the floats.
6. Reassemble the float chamber, ensuring the orientation of the floats have been maintained. Reinstall it to the bracket on the humidifier and reconnect hoses. Refer to [Figure 13 on page 66](#).



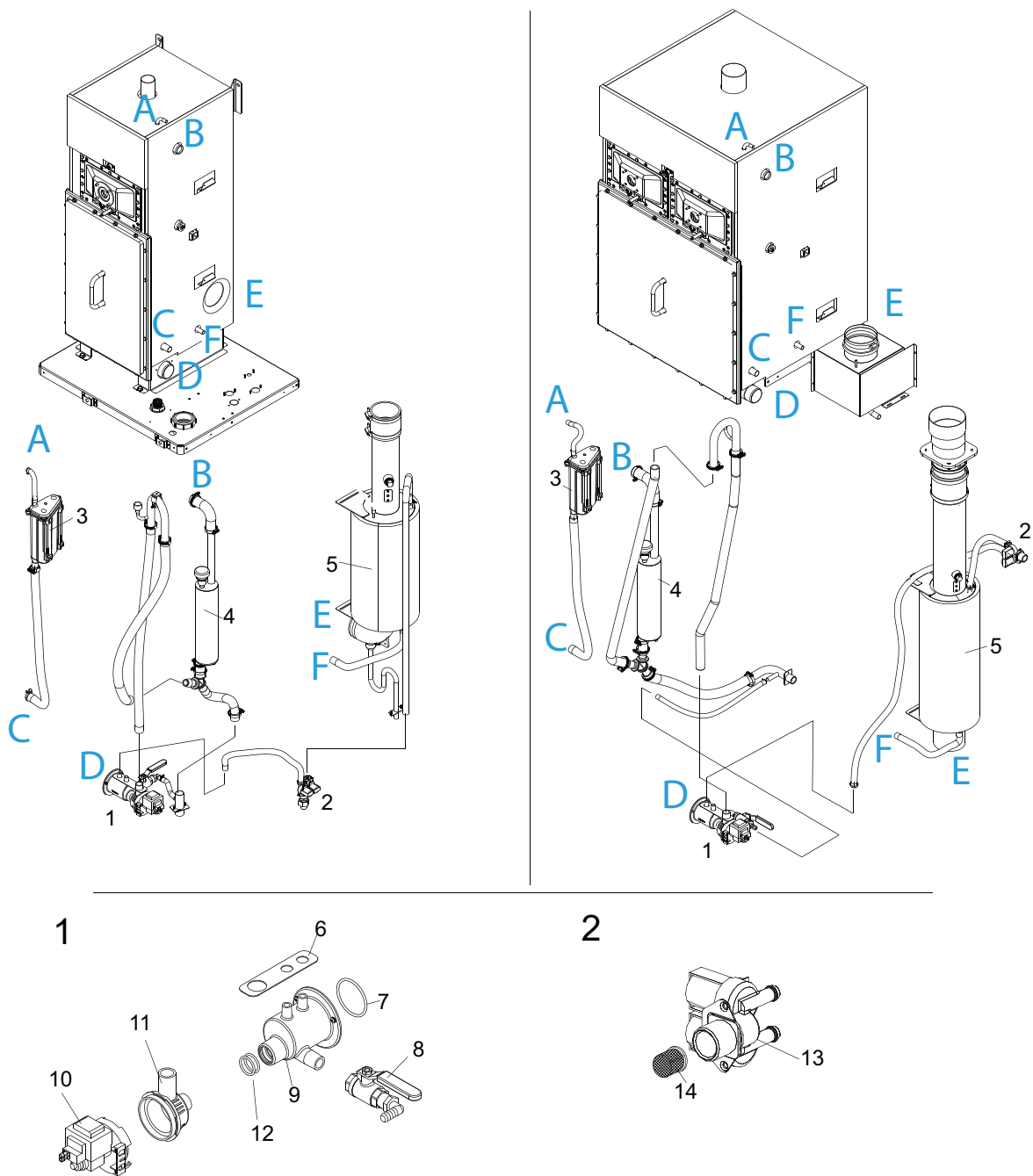

Figure 13: Cleaning Hoses, Dual Fill Valves and Drain Pump (A-G are connection points to humidifier)

- |   |               |   |   |    |                  |
|---|---------------|---|---|----|------------------|
| 1 | Drain pump    | 5 | Secondary heat-exchanger<br>(CS/NX models only) | 10 | Drain pump, 24 V |
| 2 | Fill valve    | 6 | Bracket, drain pump                             | 11 | Drain pump cover |
| 3 | Float chamber | 7 | O-ring  | 12 | O-ring (x2)      |
| 4 | P-trap        | 8 | Drain valve                                     | 13 | Dual fill valve  |
|   |               | 9 | Drain pump adapter                              | 14 | Strainer         |

## 6.5.6 Cleaning the Burner Assembly

The burner(s) in the Condair GS humidifier does not require maintenance. However, if the burner(s) is not operating properly, clean the burner(s) and spark-igniter as described below. Refer to [Figure 14](#).

1. Shut down the humidifier. Remove the plumbing cabinet door panel and make sure that the tank has been emptied.
2. Remove the four M5 nuts that secure the blower tube to the burner assembly.
3. Disengage the blower tube from the burner assembly.
4. Disconnect the ignition wire from the spark-igniter.
5. Remove the M6×12 hex-head bolts and the burner assembly. Discard the burner gasket.

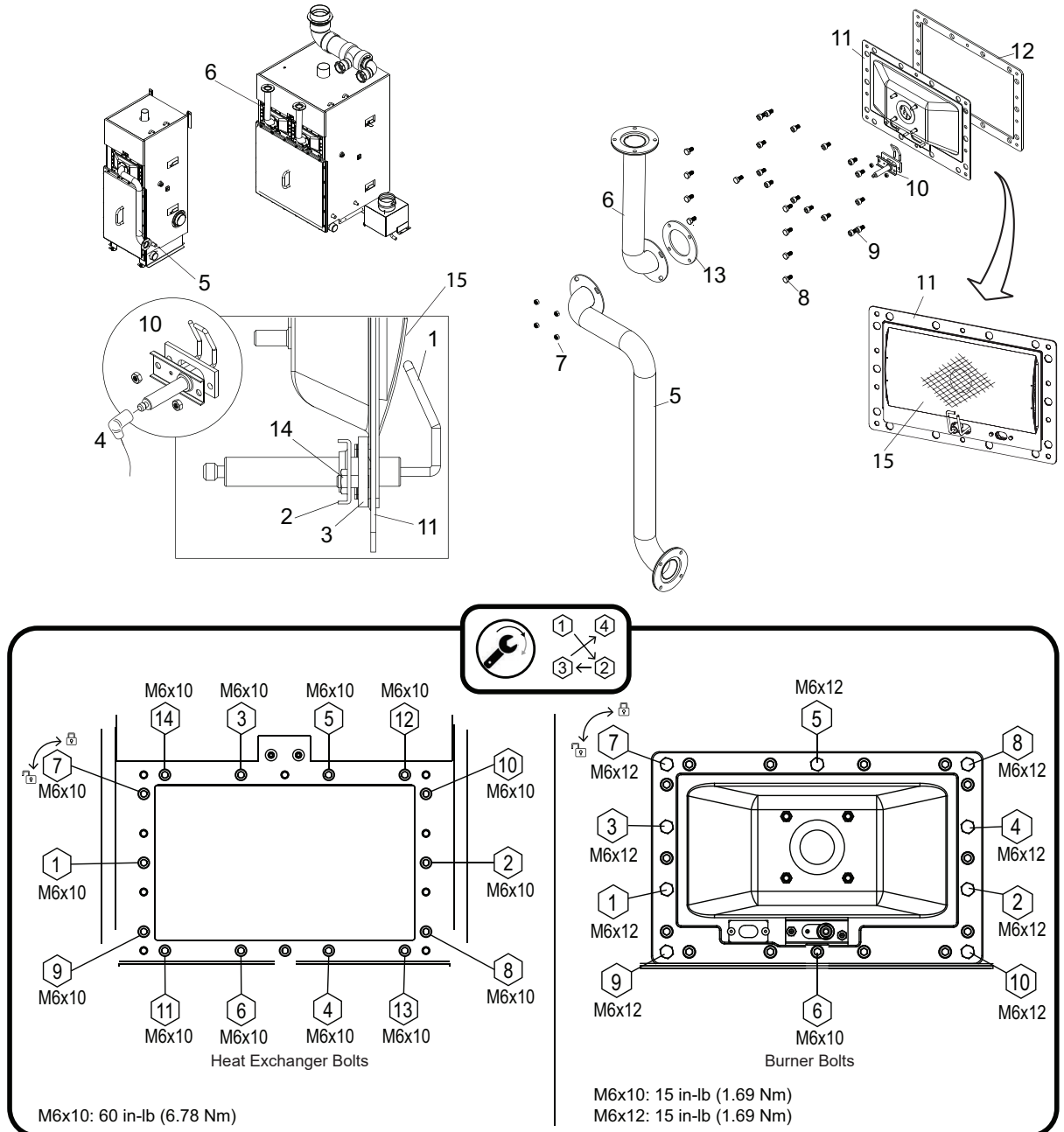

Figure 14: Cleaning the Burner Assembly

- |                                  |   |                            |
|----------------------------------|---|----------------------------|
| 1 Spark-igniter, electrode)      | 6 Blower tube, full size unit only      | 11 Burner                  |
| 2 Spark-igniter, bracket         | 7 Lock nut M5 (x4) - 10 in-lb (1.2 N-m) | 12 Burner gasket           |
| 3 Spark-igniter, gasket          | 8 M6x12 hex head (x9)                   | 13 Burner-blower gasket    |
| 4 Control wire                   | 9 M6x10 socket cap (x15)                | 14 M4 Nut (x2)             |
| 5 Blower tube, compact unit only | 10 Spark-igniter                        | 15 Burner assembly matting |

6. Visually inspect the matting on the inside surface of the burner assembly for hot spots, tears, or any clogging. If the matting has hot spots or tears, replace the burner assembly.  
If the matting is clogged, DO NOT use a scraper to remove the blockage. Use low pressure air at maximum 0.005 psi (35 Pa) to clear all blockages without damaging the matting. Blow air in the direction of the arrow.
7. Visually inspect the spark-igniter for any oxidation. Carefully remove any build-up with emery cloth. Check the electrode gap is  $1/8 \pm 1/16$  in ( $3 \pm 1.5$  mm). DO NOT adjust the gap – replace the spark-igniter, if necessary. Use a new igniter gasket.
8. Assemble the burner assembly in reverse order. Always use a new burner gasket.
9. Apply nickel anti-seize lubricant (Loctite® LB 771™ or equivalent) to the M6×12 hex-head bolts before assembly. Install with M6 lock washers. Wipe off excess lubricant.
10. On the blower tube, torque the four **M5 nuts to 10 in-lb (1.2 N·m)**.
11. Restart the unit and check that the burner(s) operates properly.

### 6.5.7 Replacing Backup Battery

Only a qualified service technician authorized by the customer should replace the backup battery on the integrated control board.

Replace the backup battery on the integrated control board as follows. Refer to [Figure 15](#).

1. Remove the door panel on the control cabinet. Swing the front panel open.
2. Replace the backup battery on the integrated control board with a new 3V battery (CR 2032).
3. Close the front panel, and install the door panel, making sure that it is fastened securely.
4. Remove the lock and tag from the external disconnect switch, and restore power to the humidifier.

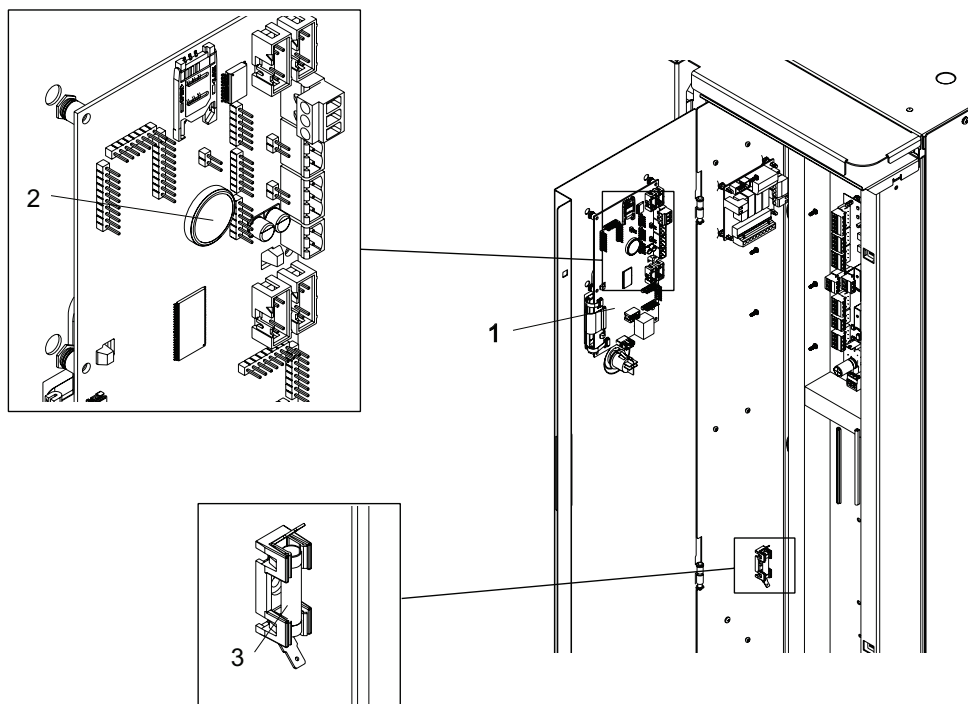

*Figure 15: Backup Battery and Fuse Replacement*

- |                             |                          |                           |
|-----------------------------|--------------------------|---------------------------|
| 1 Board, integrated control | 2 Battery – 3V (CR 2032) | 3 Slow-acting fuse (10 A) |
|-----------------------------|--------------------------|---------------------------|

### 6.5.8 Replacing Internal Fuse

Only a qualified service technician authorized by the customer should replace the internal fuse.

Replace the internal fuse in the control cabinet as follows. Refer to "[Resetting Service Reminder](#)" on page 69.

1. Remove the door panel on the control cabinet. Swing the front panel open.
2. Replace the fuse with a 10 A slow-acting fuse.
3. Close the front panel, and install the door panel, making sure that it is fastened securely.
4. Remove the lock and tag from the external disconnect switch, and restore power to the humidifier.

### 6.5.9 Resetting Service Reminder

Reset the service reminder messages and maintenance warnings in the control software after performing the required scheduled maintenance:

1. Menu > Service > General Service tab > Reset Service Reminder. A reset dialogue appears and prompts you to confirm the reset.
2. Select the <Yes> button on the confirmation screen. Select the <No> button to abort the reset.

### 6.5.10 Installing Software Updates

All software updates can be downloaded from [www.condair.com](http://www.condair.com). Download the file and extract it to a USB memory stick that has been formatted to 32-bit FAT system. The software update file (ending with .bin) should be located at the root level on the USB stick.

Install the updates for the control software as follows:

1. Set the On/Off button to the Off position and disconnect the power supply to the humidifier at the external disconnect switch. To prevent accidental power-up, lockout and tag out according to the established safety practices at your facility.
2. Remove the door panel on the control cabinet – refer to "[Removal and Installation of Access Panels](#)" on page 60 and swing the front panel open.
3. Carefully insert the USB memory stick into the USB port. The maximum **length of the memory stick should not exceed 3 in (75 mm)**.
4. Close the front panel, and install the door panel.
5. Remove the lock and tag from the external disconnect switch, and restore power to the humidifier.
6. Set the On/Off button to the On position.
7. When the Home screen appears, select the <Menu> button, then enter the password to login.



**CAUTION!**  
**Risk of file corruption!**

**DO NOT** interrupt software updating once it starts. Wait until updating is completed. Corrupted control software can render the humidifier unusable.

**Note:** If software updating is accidentally interrupted, the humidifier will not operate. However, updating can be resumed by leaving the USB key inserted in the board and power cycling the unit. The integrated control board will detect that the software was not installed properly, and restart the updating.

8. Select Administrator > Software Settings tab > Software Update to update the control software. A progress bar shows the status of the updating process. When updating is completed, the Home screen is displayed.
9. Repeat Step 1 to Step 4, and carefully remove the USB memory stick.
10. Close the front panel. Install the door panel, making sure that it is fastened securely.
11. Repeat Step 5 and Step 6 to power up the humidifier.

# 7 Fault Isolation

## 7.1 General

Troubleshooting of the Condair GS humidifier must only be performed by well qualified and well trained personnel. Electrical repairs must only be performed by a licensed electrician authorized by the customer or by Condair service technicians.

Troubleshooting the Condair GS humidifier may require personnel to access the inside of the control cabinet in the humidifier which may expose personnel and equipment to the hazards described in "[For Your Safety](#)" on page 8.

## 7.2 Fault Indication

When a condition that is not normally expected occurs, it is detected by the control software and a warning or fault message is displayed in the Service/Warning/Fault status area of the Home screen (refer to [Figure 6 on page 19](#)). The warning and fault message types are described in [Table 5 on page 21](#).

When a warning/fault condition occurs, select the warning or fault message to view the "[Fault/Service History Tab](#)" and additional details. Refer to [Figure 16](#).

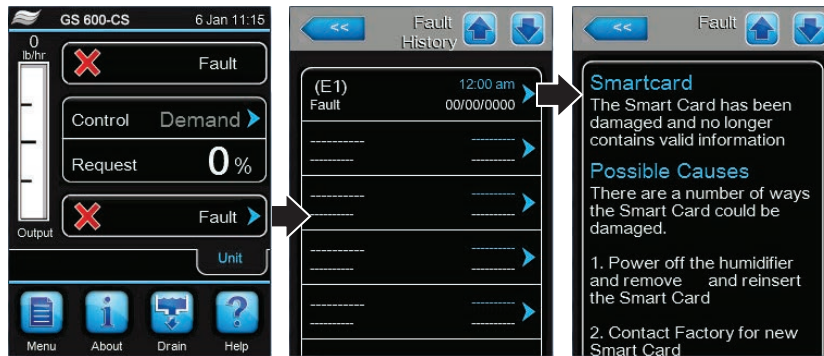

Figure 16: Fault History Screens

In addition, the Service relay in the remote fault board can also be set up to indicate that a service warning or a system warning/notification is active.

## 7.3 General Troubleshooting

**Most operational warning/fault conditions are caused by improper installation, or by not adhering to the suggested best practices for installation of the humidifier and system components.** Hence, a full fault diagnosis always requires a thorough examination of the entire system (hose connections, control systems, etc.).

[Table 13 on page 71](#) provides general guidelines for troubleshooting the humidifier. For detailed troubleshooting information of the auxiliary system components, refer to their product manuals.

The list of warning and fault messages, and corrective actions are shown in [Table 14 on page 72](#).

Table 13: General Troubleshooting – Humidifier

Problem	Probable Cause/Remedy
Nothing happens when the On/Off switch is turned On.	Incorrect voltage, or no voltage. <ul style="list-style-type: none"> <li>– Check the disconnect switch in the supply line.</li> <li>– Check the fuse between the transformer and the On/Off switch.</li> </ul>
	Step-down transformer not outputting 24 VAC. <ul style="list-style-type: none"> <li>– Check the fuse.</li> <li>– Measure and confirm 24 VAC on the transformer primary connections. Replace the transformer, if necessary.</li> </ul>
Humidifier will not produce steam, or does not reach RH setpoint value.	Safety loop is open. <ul style="list-style-type: none"> <li>– Check if the message “Safety Loop” is displayed in the operating status area of the Home screen.</li> <li>– Check if there is 24 VAC supply at low voltage terminal strip pin “2”.</li> <li>– Check that all On/Off devices connected to low voltage terminal strip pins “1” and “2” are wired properly, and their contacts are closed when they should be.</li> </ul>
	Output is limited by the high limit humidistat signal. <ul style="list-style-type: none"> <li>– Check if the high limit humidistat is installed too close to the steam distributor. The recommendation is five times the absorption distance or minimum 3 m. Check the setpoint value for the high limit – typically set at 80% RH.</li> </ul>
	No signal on Channel 1. <ul style="list-style-type: none"> <li>– Check voltage between low voltage terminal strip pins “3” and “4”. For a demand signal configuration, the signal must be 27% of full scale signal for the humidifier to start. For a transducer signal configuration, the signal must be lower than the setpoint value for the humidifier to start.</li> </ul>
	No signal on Channel 2 (on units with <a href="#">Control Channels</a> set to “Dual”). <ul style="list-style-type: none"> <li>– Check voltage between low voltage terminal strip pins “3” and “5”. For a demand signal configuration, the signal must be 27% of full scale signal for the humidifier to start. For a transducer signal configuration, the signal must be lower than the setpoint value for the humidifier to start.</li> </ul>
	Capacity has been manually limited. <ul style="list-style-type: none"> <li>– Check/adjust <a href="#">Manual Capacity</a>, if necessary.</li> </ul>
Humidifier displays warning or fault message.	The control software has detected an abnormal condition. <ul style="list-style-type: none"> <li>– Refer to <a href="#">“Warning and Fault List” on page 72</a>.</li> </ul>

## 7.4 Warning and Fault List

[Table 14](#) shows the list of warning and fault messages triggered by the control software in the humidifier, and the corrective actions. The warning code escalates to a fault code if the alarm condition is not resolved within a certain period of time. After fixing a fault condition, reset the fault status as described in ["Resetting Fault Status" on page 78](#).

Table 14: Warning and Fault List

Code		Message	Probable Cause/Remedy
Warning	Fault		
W01	E01	Smartcard missing	No communication with the SIM card.
			The SIM card may not be seated properly on the integrated control board. Check that the SIM card is seated properly.
			Defective SIM card. Contact your Condair representative.
W06	-	Main Unit Missing (or) Extension Missing (No Signal Warning)	No communication between the Extension unit and the Main unit in the Linkup chain. Operation is interrupted until a signal is received.
			The Linkup configuration between the Main and Extension unit is not set correctly. - Check the Linkup configuration.
			The Main unit or Extension unit may be switched off. - Switch on the Main and/or Extension unit.
			Loose connection. - Check the connection between the Main and Extension units.
W07	-	Ext Fault	An Extension unit has a fault condition which was communicated to the Main unit.
			Alarm condition in the Extension unit(s). - Check the Extension unit(s).
-	E10	CTRLR Fault (or) Memory (or) CTRLR Reset	Flash memory read/write fault. - Contact your Condair representative.
W22	E22	Fill Warning (W22) Fill Timeout (E22)	The fill valve(s) have been active for an extended length of time and the water level is still zero. The dual fill valves remain activated. The Fill Warning will eventually become a Fill Timeout if the issue has not been addressed.
			Water supply problems. - Make sure that the water supply line is open, and there is adequate flow and pressure.
			Loose wiring, or clogged strainer in dual fill valves. - Check the wiring to the float board and the dual fill valves. - Check the strainer in the dual fill valves is not clogged – refer to <a href="#">"Cleaning Hoses, Dual Fill Valves and Drain Pump" on page 65</a> .
			Drain pump running, or manual drain valve open. - Check that the manual drain valve is closed, and the drain pump is not running.
			Floats may be stuck. - Visually check that the different LEDs on the float board light up as the water level in the float chamber changes. If necessary, clean the float chamber – refer to <a href="#">"Cleaning the Float Chamber" on page 64</a> .
			Fill valve relay on the driver board not seated properly, or defective. <b>CAUTION!</b> Electro-static discharge damage to board. - Check that LED3 (corresponding to REL4 for the high volume fill valve) and LED4 (corresponding to REL5 for the low volume fill valve) on the driver board light up when the fill valves are supposed to be energized. If not, check the relay(s) is seated properly on the driver board. - Swap the relay(s) with another relay on the board to verify that it is working. If necessary, replace the relay.
			Defective dual fill valves. - Check for 24 VAC on the pins of the dual fill valves. If necessary, replace the dual fill valves. Reconnect the wires correctly.
			Scale build-up in the drain fitting. - Clean the drain fitting, as described in <a href="#">"Cleaning the Tank" on page 62</a> .

Code		Message	Probable Cause/Remedy
Warning	Fault		
W28	E28	Maintenance Due Warning	The preset service interval time has elapsed. The unit will continue to run for 200 hours before a fault message is generated. The unit will not operate if the warning message escalates to a fault message. <b>IMPORTANT! Perform the required scheduled maintenance, then reset the service reminder before restarting the unit.</b>
		Maintenance Due Fault (on fault)	Unit needs to be serviced. – Refer to <a href="#">"Maintenance" on page 55</a> for maintenance procedures. – Reset the service reminder after performing the required scheduled maintenance – refer to <a href="#">"Resetting Fault Status" on page 78</a> .
W29	E29	Exhaust Service	The maintenance of the parts and connections of the exhaust gas system is due. After 7500 hours of operation, the GS will continue to humidify for another 500 hours before error E29 appears and the device stops permanently. If stainless steel exhaust elbows are installed, error E29 can be deactivated via the software.
			– Check parts of the exhaust gas system and replace parts if necessary. – Replace silicone exhaust gas elbows with exhaust elbows made of stainless steel. – Check the connecting cuffs and replace if necessary
W32	–	RH Signal	The RH input is less than 3%. Operation is interrupted until an input higher than 3% is received.
			Loose wiring, faulty sensor. – Check the connection between the sensor and the unit. – Swap the sensor with another sensor and verify that it is working. If necessary, replace the sensor.
			Layout of the humidifier control system may be causing signal interference. – Check that the controls layout permits accurate readings.
W34	–	Remote Disabled	The unit has been disabled remotely by the building management system (BMS) through Modbus communication. Operation is interrupted until the unit is enabled again through Modbus or the control software.
			Unit disabled by the BMS. – Enable the unit through the BMS. – If unit cannot be enabled remotely, try enabling the unit through the <a href="#">Modbus</a> setting in the control software.
W35	–	BMS T/O (timeout)	The maximum wait time without any communications from the BMS has been exceeded. If the signal <a href="#">Source</a> is set to "Analog", the humidifier will continue operating; otherwise it stops producing steam until communications with the BMS is re-established.
W42	–	RH High Warning	Sensed humidity is above the <a href="#">RH High</a> value configured in the control software. The unit will remain idle until the sensed RH value drops below the setpoint value.
			Incorrect layout of the humidifier control system (sensor location too close to steam distributor or other sources that affect measurement), or defective components. – Check the humidifier control system.
			Humidifier capacity too large for the space being humidified. – Limit the output capacity of the humidifier – refer to <a href="#">Manual Capacity</a> . – Adjust the <a href="#">Proportional / Integral value</a> of the controller.
			The <a href="#">RH High</a> value for the sensor signal may be set too low. – Adjust the RH High value for the sensor signal.
W43	–	RH Low Warning	Sensed humidity is below the minimum value configured in the control software. The unit should continue operating unless it is in standby mode.
			Incorrect layout of the humidifier control system (sensor location too close to steam distributor or other sources that affect measurement), or defective components. – Check the humidifier control system.
			The <a href="#">RH Low</a> value for the sensor signal may be set too high. – Adjust the RH Low value for the sensor signal.
			Unit may be in standby mode. – Check the safety loop is closed, and that all burners are operational.

Code		Message	Probable Cause/Remedy
Warning	Fault		
-	E46	Drain Check	The drain pump has been active for an extended period of time without the water level changing in the float chamber. The unit needs to drain for optimal performance. Fix the problem before restarting the unit.
			Back pressure in the drain line may be causing slow drain. – Remove any blockages in the drainage system.
			Loose connection. – Check the connections between the float board and the driver board, as well as the drain pump.
			Floats may be stuck. – Visually check that the different LEDs on the float board light up as the water level in the float chamber changes. If necessary, clean the float chamber – refer to <a href="#">"Cleaning the Float Chamber" on page 64</a> .
			Drain pump may be clogged. – Clean the drain pump – refer to <a href="#">"Cleaning Hoses, Dual Fill Valves and Drain Pump" on page 65</a> .
W52	-	Float Inconsistent	On unit startup the float levels do not rise logically from low water level L1 (red LED) to high water level L5 (yellow LED).
			Excess back pressure in the steam line. – Check the steam line.
			Float level sensor may be malfunctioning. – Inspect all hoses and connections. – Clean the float chamber – refer to <a href="#">"Cleaning the Float Chamber" on page 64</a> .
W57	-	Startup Code	Activation code required to use the humidifier.
			Activation code missing. – Contact your Condaire representative.
-	E84	Driver Board Fault	No communication between the integrated control board and the driver board.
			Dip switch settings are not correct. – Verify dip switch settings.
			Communication cable between the driver board and the integrated control board not connected properly. – Make sure the RS485 cable is connected to J15 (RS4851) on the driver board, and J12 on the integrated control board. – With the unit powered up, check that LED1 and LED10 on the driver board are flashing. Otherwise, contact your Condaire representative.
			Unspecified driver board fault. – Check that the heartbeat LED10 on the driver board is blinking. Otherwise, contact your Condaire representative.
-	E138	Over-Temperature Fault	The exhaust or tank safety sensor has exceeded the safety limit. The unit will not operate when this fault condition is active. Fix the problem first, then reset the over-temperature switch as described in <a href="#">"Resetting Fault Status" on page 78</a> .
			Unit may be operating with incorrect water level. – Check that the float chamber is operating properly.
			Exhaust vent may be blocked. – Make sure that the exhaust vent is free of obstructions.
			Dual fill valves may not be working properly. – Refer to the troubleshooting procedure for fault code <a href="#">"Fill Check Fault"</a> .
			Thermocouple wire may be damaged. – Visually inspect the thermocouple wire for kinks or other damage.
			Excess scale build-up on the coils of the primary heat-exchanger. – Remove scale build-up – refer to <a href="#">"Cleaning the Tank" on page 62</a> .
			Temperature of the water supply may be too high. – Check that the temperature of the water supply. For optimal performance, temperature must not exceed 70 °F (21 °C).
			Exhaust condensate removal (on CS/NX model) may be blocked. – Check for blockages in the exhaust drain line in the unit.
W139	-	No Burners Available	All burners have been disabled through the control software. No burners are available for operation of the unit. The unit will not respond to a demand until one or more burners is enabled.
			Burners disabled. – Enable the <a href="#">Burners</a> in the control software.

Code		Message	Probable Cause/Remedy
Warning	Fault		
-	E140	Keep Warm Fault	The <a href="#">Keep Warm</a> function is activated, but the tank temperature has not increased in the allotted time.
			Loose connection. - Check the tank temperature sensor connection.
			Burners may be disabled. - Check that no more than <b>one</b> burner is disabled in the control software.
			Scale build-up on the temperature sensor. <b>CAUTION!</b> The tank may be hot to the touch. - Carefully remove scale build-up on the sensor as described in <a href="#">"Cleaning the Tank" on page 62</a> .
			Defective temperature sensor. <b>CAUTION!</b> The tank may be hot to the touch. - Check the tank to see if it is hot. Then check the electrical signal to the sensor. Replace the sensor, if defective.
W141		Ignition Fail	The ignition module identified has failed to ignite within the allotted time (4 minutes). The unit will index to next available burner in the sequence.
			Loose wiring, or defective spark-igniter. - Visually check the sight port of problematic burner. - Check if sparking can be seen or heard during the ignition sequence. - Check if the burner ignites, but stops after 3 seconds. - Remove and clean oxidation on the igniter. - Check the distance between the 'spark gap'. - Check the spark-igniter connection. If necessary, replace the spark-igniter.
			Gas supply problem. - Check the gas supply is open. - Check for 24 VAC at the gas valve. - Check the status LED on the ignition control module – three flashes of the red LED indicate problem with the supply, or gas valve, or a loose connection. Contact your Condair representative if further assistance is required.
			Faulty ignition control module. - Check the status LED on the ignition control module – a solid red LED indicates an ignition control module failure. Replace the ignition control module, if necessary.
			Incorrect gas valve adjustments. - Check if the throttle adjustment on the gas valve has been tampered.
-	E142	No Burners Available	All burners have experienced an ignition control module failure, and no burners are available to produce steam. The unit is unsafe to operate with this fault condition. Fix the problem before restarting the unit.
			Gas supply problem. - Check the gas supply is open. - Check for 24 VAC at the gas valve. - Check the status LED on the ignition control module – three flashes of the red LED indicate problem with the supply, or gas valve, or a loose connection. Contact your Condair representative if further assistance is required.
			Loose wiring, or defective spark-igniter. - Visually check the sight port of problematic burner – check for a glowing red spark-igniter followed by a flame. - Check the spark-igniter connection. If necessary, replace the spark-igniter.
			Faulty ignition control module. - Check the status LED on the ignition control module – a solid red LED indicates an ignition control module failure. Replace the ignition control module, if necessary.

Code		Message	Probable Cause/Remedy
Warning	Fault		
-	E143	Gas Valve Fail	The identified gas valve was energized out of sequence, or when it was not expected to be energized. The unit is unsafe to operate with this fault condition. Fix the problem before restarting the unit.
			Loose connections. <ul style="list-style-type: none"> <li>- Make sure that all onboard electronics are connected according to the wiring diagram.</li> <li>- Check the status LED on the ignition control module – three flashes of the red LED indicate problem with the supply, or gas valve, or a loose connection.</li> <li>- Check connections to all ignition control modules and gas valves. Check for 24 VAC at location labelled "TH" on the ignition control module.</li> </ul>
			Faulty gas valve. <ul style="list-style-type: none"> <li>- Check for voltage at locations labelled "TH" and "V2" on the ignition control module after the blower has completed pre-purging the system. If 24 VAC voltage is detected at "V2" but not at "TH", replace the gas valve. Contact Condaire to order a replacement gas valve.</li> </ul>
-	E144	Float Level	On three consecutive occasions, more than one float level was registering at the same time. The unit cannot operate without accurate float level reading. Fix the problem before restarting the unit.
			Floats may not be working properly. <ul style="list-style-type: none"> <li>- Check the float chamber for scale build-up, and clean if necessary – refer to <a href="#">"Cleaning the Float Chamber" on page 64</a>.</li> <li>- Check that both floats have equal buoyancy, as described in <a href="#">"Cleaning the Float Chamber" on page 64</a>. Replace the floats, if necessary.</li> </ul>
			Faulty float board <ul style="list-style-type: none"> <li>- Examine the float board for signs of corrosion, splashed water on it, or other damage. Replace the float board, if necessary.</li> </ul>
			Obstructions in hoses, or hoses plumbed incorrectly. <ul style="list-style-type: none"> <li>- Check for obstructions in the hoses.</li> <li>- Check that all hoses are plumbed correctly.</li> </ul>
-	E145	Fill Check Fault	The dual fill valves have been active for an extended period of time without the water level rising in the float chamber. The unit will not operate without an accurate water level reading. Fix the problem before restarting the unit.
			Water supply problems. <ul style="list-style-type: none"> <li>- Make sure that the water supply line is open, and there is adequate flow and pressure.</li> </ul>
			Loose wiring, or clogged strainer in dual fill valves. <ul style="list-style-type: none"> <li>- Check the wiring to the float board and the dual fill valves.</li> <li>- Check the strainer in the dual fill valves is not clogged – refer to <a href="#">"Cleaning Hoses, Dual Fill Valves and Drain Pump" on page 65</a>.</li> </ul>
			Drain pump running, or manual drain valve open. <ul style="list-style-type: none"> <li>- Visually check that the manual drain valve is closed, and the drain pump is not running.</li> </ul>
			Floats may be stuck. <ul style="list-style-type: none"> <li>- Visually check that the different LEDs on the float board light up as the water level in the float chamber changes. If necessary, clean the float chamber – refer to <a href="#">"Cleaning the Float Chamber" on page 64</a>.</li> </ul>
			Fill valve relay on the driver board not seated properly, or defective. <b>CAUTION!</b> Electro-static discharge damage to board. <ul style="list-style-type: none"> <li>- Check that LED3 (corresponding to REL4 for the high volume fill valve) and LED4 (corresponding to REL5 for the low volume fill valve) on the driver board light up when the fill valves are supposed to be energized. If not, check the relay(s) is seated properly on the driver board.</li> <li>- Swap the relay(s) with another relay on the board to verify that it is working. Replace if necessary.</li> </ul>
			Defective dual fill valves. <ul style="list-style-type: none"> <li>- Check for 24 VAC on the pins of the dual fill valves. If necessary, replace the dual fill valves. Reconnect the wires correctly.</li> </ul>
			Scale build-up in the drain fitting. <ul style="list-style-type: none"> <li>- Clean the drain fitting, as described in <a href="#">"Cleaning the Tank" on page 62</a>.</li> </ul>

Code		Message	Probable Cause/Remedy
Warning	Fault		
-	E146	Blower Not Operating	The identified blower is not operating, or registered a value below 500 rpm while being energized. The unit is unsafe to operate with this fault condition. Fix the problem before restarting the unit.
			Loose connections. - Check the PWM (pulse width modulation) and power connection to the blower.
			Blower relay on driver board may be defective. <b>CAUTION!</b> Electro-static discharge damage to board. - Visually check that LED7 (corresponding to relay REL8 for the blower) on the driver board lights up when the blower is supposed to be energized. If LED7 does not light up, the relay is faulty. - Replace the driver board. Refer to the GS Spare Parts List.
			Blower feedback signal may be missing. - Restart the unit, and check the blower rpm in <a href="#">Input Diagnostics</a> in the control software. If the rpm is low, contact your Condaire representative.
			Restrictions at blower, or damaged blower. - Visually inspect the blower and blower inlet for restrictions. - Visually inspect the blower impeller for damage. Order a replacement blower, if necessary.
			Main power to blower relay damaged. - Visually inspect the connections between the main power. - Visually inspect the blower relay for damage and replace if necessary.
			Worn out blower. - The blower speed may decrease due to wear. The blower is safe to operate, but the output may be reduced. Order a replacement blower.
W147	-	Blower RPM Low	The blower identified is running at a lower rpm than expected by more than the allowable tolerance. The unit will continue monitoring the blower rpm.
			Loose connections. - Check the PWM and power connection to the blower.
			Low voltage. - Visually check that LED7 (corresponding to relay REL8 for the blower) on the driver board lights up when the blower is supposed to be energized. - Check for 120 VAC on the output side of the blower relay.
			Restrictions at blower, or damaged blower. - Visually inspect the blower and blower inlet for restrictions.
			Worn out blower. - The blower speed may decrease due to wear. The blower is safe to operate, but the output may be reduced. Order a replacement blower.
W148	-	Blower RPM High	The blower identified is running at a higher rpm than expected by more than the allowable tolerance. The unit will continue monitoring the blower rpm and display this warning if the rpm remains high.
			Loose connection. - Check the PWM connection to the blower.
W149	E149	AP Open Warn	The air proving switch identified has opened while the unit was operating or during blower start-up. The unit will interrupt operation and retry three times. After a third attempt a fault message is generated. The unit is unsafe to operate with this fault condition. Fix the problem before restarting the unit.
			Blockage in the air intake vent or air intake terminal. - Visually inspect the air intake vent and air intake terminal for blockages.
			Defective air proving switch. - Check that the air proving switch remains closed during operation of the blower. Check for suction in the pressure tubes. If the air proving switch does not close, it may be defective and must be replaced.
			Pressure tubes not connected, or loose wiring. - Check the pressure tube connections are attached securely. - Check the wiring between the air proving switch(es) and connector J2 on the driver board. With demand off and the blower not operating, check for 24 VAC at pins 1 and 2 on connector J2.
			Exhaust condensate removal (on CS model) may be blocked. - Check for blockages in the exhaust drain line in the unit.

Code		Message	Probable Cause/Remedy
Warning	Fault		
-	<b>E153</b>	AP Exhaust Fault	<p>One or more of the external safety switches installed for the Exhaust in Duct feature have opened.</p> <ul style="list-style-type: none"> <li>- Safety switches have been wired incorrectly. Verify for the proper installation of all safety switches, and verify that the switches have been wired correctly to the controls low-voltage terminal.</li> <li>- Verify that the air handling system is operational.</li> </ul>

## 7.5 Resetting Fault Status

With the exception of the over-temperature fault, the following procedure should be used to reset all other fault conditions including the ignition control module safety lockout.

Reset the "Fault" status as follows:

1. Correct the cause of the problem.
2. Set the On/Off button to the Off position. Wait approximately for 5 seconds, then set the On/Off button to the On position. If the alarm condition has been eliminated, the fault message is automatically reset; otherwise the fault message reappears after a short while.

### Resetting Over-Temperature Fault

Reset the over-temperature "Fault" status as follows:

1. Correct the cause of the problem and wait for the unit to cool down.
2. Press the reset button on the over-temperature switch.
3. Set the On/Off button to the Off position. Wait approximately for 5 seconds, then set the On/Off button to the On position. If the alarm condition has been eliminated, the fault message is automatically reset; otherwise the fault message reappears after a short while.

# 8 Decommissioning

## 8.1 General

If the Condair GS humidifier needs to be removed from service (for disposal or long-term storage), strictly follow all instructions in this chapter.

### Personnel Qualifications

Decommissioning of the Condair GS humidifier must only be performed by a qualified service technician authorized by the customer. It is the customer's responsibility to verify qualifications of the personnel.

### Safety

Decommissioning of the Condair GS humidifier will require personnel to access the inside of the control and plumbing cabinets in the humidifier, which may expose personnel and equipment to the hazards. Refer to ["For Your Safety" on page 8](#).

## 8.2 Removal from Service for Disposal or Long-term Storage

Remove the Condair GS humidifier from service (for disposal or long-term storage) as follows:

1. Drain the tank, and shut down the humidifier as described in ["Shutting Down" on page 53](#). Follow all safety precautions.
2. Disconnect the gas connection to the humidifier.
3. Disconnect and remove the power supply to the Condair GS humidifier. Refer to "Wiring Diagrams" in the Installation Manual.
4. Disconnect and remove the control signal inputs to the humidifier.
5. Disconnect the steam and condensate lines, and empty out all fluids.
6. Disconnect the water and drain connections to the humidifier.
7. Disconnect and remove the intake and exhaust vents.
8. Remove the humidifier from its mounting surface.
9. If the Condair GS humidifier is to be put into long-term storage, store the humidifier in its original packaging inside a protected area that meets the following requirements:
  - Room temperature: 41 to 104 °F (5 to 40 °C)
  - Room humidity: 10 to 75% RH
10. If the Condair GS humidifier is to be disposed off, refer to ["Disposal/Recycling"](#).

## 8.3 Disposal/Recycling

The Condair GS humidifier should not be disposed off in domestic waste, and should only be disposed off in accordance with local regulations at authorized collection facilities.

If you have any questions, contact the appropriate local authorities or your local Condair representative.

# 9 Performance and Operating Data

## 9.1 Performance Data

Condair Model	Minimum Input (gross) BTUh (kW)		Maximum Input (gross) BTUh (kW)		Min./Max. Steam Capacity lb/h (kg/h)
	Natural Gas	Propane *	Natural Gas	Propane *	
GS 50-CS	12,400 (3.6)	13,000 (3.8)	62,000 (18.2)	62,000 (18.2)	10-50 (4.5-23)
GS 50-NX	13,000 (3.8)	–	65,000 (19.0)	–	10-50 (4.6-23)
GS 50-MT	14 000 (4.1)	–	70 000 (20.5)	–	10-50 (4.6-23)
GS 100-CS	24,800 (7.3)	24,800 (7.3)	124,000 (36.3)	124,000 (36.3)	20-100 (9-45)
GS 100-NX	26,000 (7.6)	–	120,000 (35.2)	–	20-100 (9-45)
GS 100-MT	28 000 (8.2)	–	140 000 (41.0)	–	20-100 (9-45)
GS 150-CS	37,200 (10.9)	37,200 (10.9)	186,000 (54.5)	186,000 (54.5)	30-150 (13.6-68)
GS 150-NX	39,000 (11.4)	–	187,500 (55.0)	–	30-150 (13.6-68)
GS 150-MT	42 000 (12.3)	–	210 000 (61.5)	–	30-150 (13.6-68)
GS 200-CS	24,800 (7.3)	24,800 (7.3)	248,000 (72.7)	248,000 (72.7)	20-200 (9-91)
GS 200-NX	26,000 (7.6)	–	240,000 (70.3)	–	20-200 (9-91)
GS 200-MT	28 000 (8.2)	–	280 000 (82.1)	–	20-200 (9-91)
GS 300-CS	37,200 (10.9)	37,200 (10.9)	372,000 (109.0)	372,000 (109.0)	30-300 (13.6-136)
GS 300-NX	39,000 (11.4)	–	375,000 (109.9)	–	30-300 (13.6-136)
GS 300-MT	42 000 (12.3)	–	420 000 (123.1)	–	30-300 (13.6-136)
GS 450-CS	37,200 (10.9)	37,200 (10.9)	558,000 (163.5)	558,000 (163.5)	30-450 (13.6-204)
GS 450-NX	39,000 (11.4)	–	562,500 (164.9)	–	30-450 (13.6-204)
GS 450-MT	42 000 (12.3)	–	630 000 (184.6)	–	30-450 (13.6-204)
GS 600-CS	37,200 (10.9)	37,200 (10.9)	744,000 (218.0)	744,000 (218.0)	30-600 (13.6-272)
GS 600-NX	39,000 (11.4)	–	750,000 (219.8)	–	30-600 (13.6-272)
GS 600-MT	42 000 (12.3)	–	840 000 (246.2)	–	30-600 (13.6-272)

\* On-site conversion kits between propane and natural gas are available.

## 9.2 Operating Data for GS Series II Indoor Models

Control Signal Input Types:	
Active	0-5 VDC, 1-5 VDC, 0-10 VDC, 2-10 VDC, 0-20 VDC, 0-16 VDC, 3.2-16 VDC, 0-20 mADC, 4-20 mADC
Passive	135-10 kΩ ohmic humidity sensor
On/Off control	<2.5 VDC Off, 2.5-20 VDC On
Digital (via Modbus, BACnet IP/MSTP)	BACnet IP, BACnet MSTP, Modbus, LonWorks (Option), BACnet MSTP BTL-Certified (Option), BACnet IP BTL-Certified (Option)

Ambient Conditions:	
Ambient temperature	41-104 °F (5-40 °C)
Relative humidity	5-80% (non-condensing)

Combustion Air:	
Combustion air maximum temperature	86 °F (30 °C)

Efficiency	Combustion Air CFM						
	GS 50	GS 100	GS 150	GS 200	GS 300	GS 450	GS 600
MT	15	30	46	61	91	137	182
NX	14	26	41	52	81	122	163
CS	13	27	40	54	81	121	162

<b>Backpressure:</b>	
Maximum permissible backpressure (duct static pressure and line backpressure)	6 in H <sub>2</sub> O (1.49 kPa) for compact unit 10 in H <sub>2</sub> O (2.49 kPa) for full-size unit

<b>Gas Operating Pressure:</b>	
Natural gas	4.5-10.0 in H <sub>2</sub> O (1.1-2.4 kPa)
Propane	9.0-13.0 in H <sub>2</sub> O (2.2-3.2 kPa)

\* On-site conversion kits between propane and natural gas are available.

<b>Water Supply:</b>	
Water pressure (regulated)	30-80 psig (3.0-8.0 bar, 300-800 kPa)
Flow rate	2.6 gpm (10 l/min) for Condair GS 50-300, 5.3 gpm (20 l/min) for Condair GS 450-600
Water temperature	34-59 °F (1-15 °C) recommended; maximum 77 °F (25 °C)
Water quality	Cold potable water filtered to 5 µm, hardness of 0 - 20.42 gpg (0 - 350 ppm), pH level between 6.5 - 8.5 * and chloride 0-40 ppm **. * If pH is >7.5 and the content of Sodium and/or sulfates are also high, the risk of foaming is increased. ** Damage caused by chloride corrosion is not covered by your Condair warranty.

<b>Drain Water:</b>	
Drain water temperature	140 °F (60 °C) maximum (with drain water cooling), 212 °F (100 °C) (without drain water cooling)
Drainage capacity	5.3 gpm (20 l/min)

<b>Power:</b>	
Maximum current draw	15 A (slow acting fuse)

<b>IP Rating:</b>	
IP20 for all units	

**Notes**

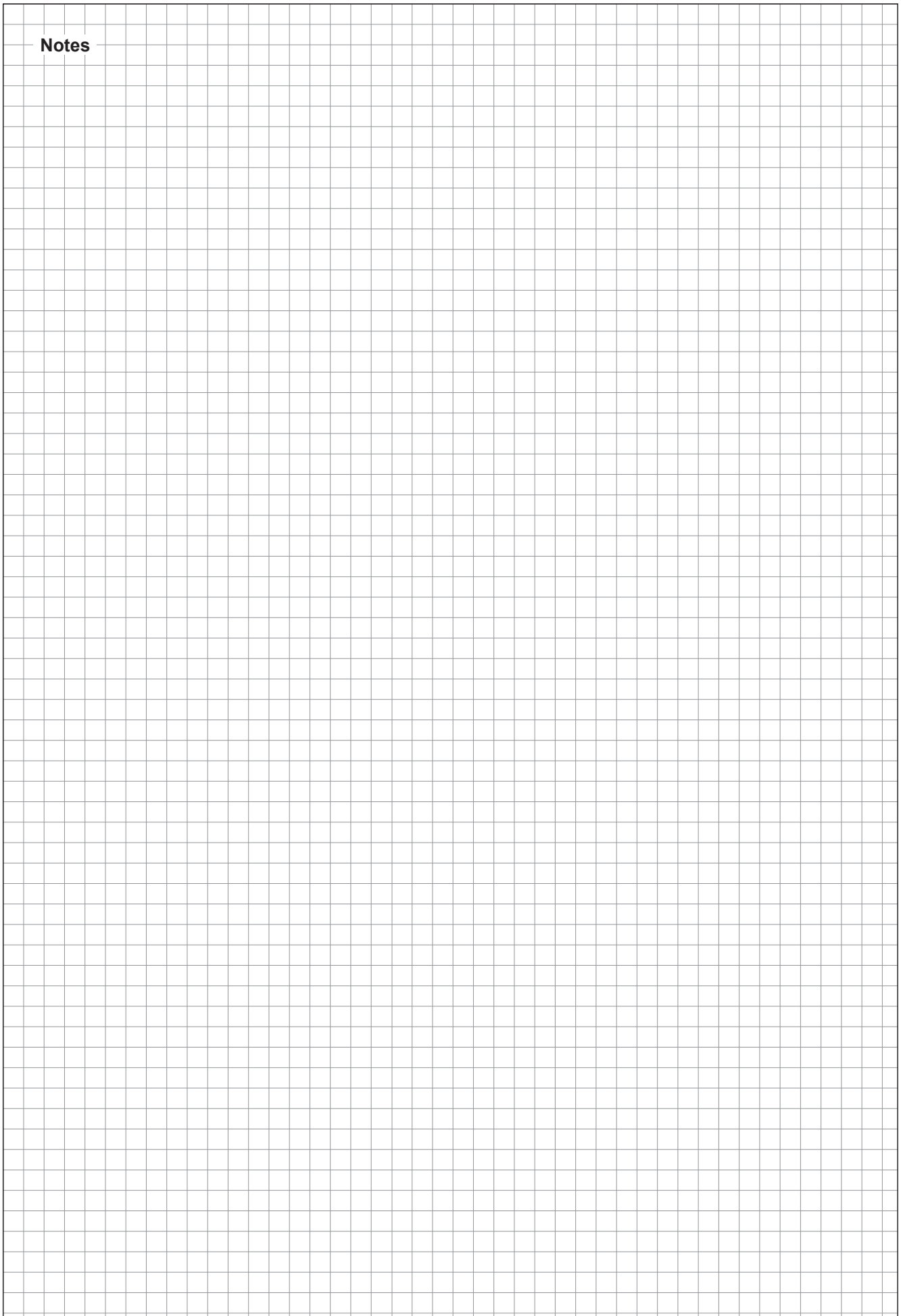

# Warranty

---

Condair Inc. or Condair Ltd. (depending on the entity that supplied the product, and hereinafter collectively referred to as CONDAIR) warrant for a period of two years after installation or 30 months from the manufacturer's ship date, whichever date is earlier, that CONDAIR's manufactured and assembled products, not otherwise expressly warranted, are free from defects in materials and workmanship. Notwithstanding the foregoing, the products listed below have an alternate warranty period:

- GS/GSTC Series heat exchanger(s) are warranted to be free from defects in materials and workmanship for a period of 3 years from installation or 40 months from the manufacturer's ship date, whichever is earlier.
- SAM-e Short Absorption Manifolds, except for the coupling seals, are warranted to be free from defects in materials and workmanship for a total period of 10 years from the manufacturer's ship date.
- Humilife RH humidifiers are warranted to be free from defects in materials and workmanship for a period of 5 years from the manufacturer's ship date. CONDAIR may, at its discretion, replace individual components or Humilife RH units as a whole.
- Spare Parts used for repairs are warranted for the balance of the term of the warranty on the original humidifier or 90 days, whichever is longer.
- No warranty is made against corrosion, deterioration, or suitability of substituted materials used as a result of compliance with government regulations.

CONDAIR's obligations and liabilities under this warranty are limited to furnishing replacement parts to the customer, F.O.B. CONDAIR's factory. The replacement parts are warranted for the balance of the term of the warranty on the original humidifier or 90 days, whichever is longer. Procedure:

1. Customer Requests Warranty as per instructions on the CONDAIR Warranty Form.
2. CONDAIR reviews the warranty claim and will respond in one of two ways:
  - a. Warranty Accepted – Replacement Part or credit granted.
  - b. Warranty Declined – Response with justification will be provided to the customer.
3. In some cases, CONDAIR may request the part to be returned, freight prepaid by the customer, as part of the warranty acceptance or warranty determination process. Some reasons include:
  - a. Part must be analyzed to determine the root cause of failure.
  - b. Part must be returned to the supplier for claim/investigation.

When parts are requested to be returned, replacement parts will be sent by CONDAIR to the customer against an invoice from CONDAIR paid by the customer. The cost of the replacement parts will be reimbursed to the customer with a credit note after the parts are received and analyzed by CONDAIR, if the warranty is accepted.

The warranties set forth herein are in lieu of all other warranties expressed or implied by law. No liability whatsoever shall be attached to CONDAIR until said products have been paid for in full and then said liability shall be limited to the original purchase price for the product. Any further warranty, with the exception of a purchased extended warranty described below, must be in writing, and signed by an officer of CONDAIR.

CONDAIR makes no warranty and assumes no liability unless the equipment is installed in strict accordance with the installation manual in effect at the date of purchase, and by properly qualified and licensed professionals capable of installing such equipment.

CONDAIR makes no warranty and assumes no liability whatsoever for consequential damage or damage resulting directly from misapplication, incorrect sizing, or lack of proper maintenance of the equipment.

CONDAIR makes no warranty and assumes no liability whatsoever for damage to the products, humidifier, supply lines, drain lines, steam distribution systems, or the building as a whole caused by freezing.

CONDAIR reserves the right to change the design, specifications, and performance criteria of its products without notice or obligation.

## Extended Warranty

Extended warranties are available to purchase under the conditions listed above. Extended warranties must be purchased at the time of the original equipment order.



[www.condairparts.com](http://www.condairparts.com)

Buy authentic Condair parts factory direct.

Would you recommend Condair?  
Take our two question survey.



**U.S.A.**  
1021 6th Street  
Racine, WI 53403

**CANADA**  
2740 Fenton Road  
Ottawa, Ontario K1T 3T7

TEL: 1.866.667.8321  
EMAIL: [na.info@condair.com](mailto:na.info@condair.com)  
WEBSITE: [www.condair.com](http://www.condair.com)

