



INSTALLATION AND OPERATION MANUAL

Adiabatic humidification system
Condair MLP RO

Thank you for choosing Condair

Installation date (MM/DD/YYYY):

Commissioning date (MM/DD/YYYY):

Site:

Model:

Serial number:

Manufacturer

Condair A/S
Parallevej 2, DK-8680 Ry
phone +45 8788 2100
condair.dk@condair.com, www.condair.dk

Proprietary Notice

This document and the information disclosed herein are proprietary data of Condair A/S. Neither this document, nor the information contained herein shall be reproduced, used, or disclosed to others without the written authorization of Condair A/S, except to the extent required for installation or maintenance of recipient's equipment.

Liability Notice

Condair A/S does not accept any liability due to incorrect installation or operation of the equipment or due to the use of parts/components/equipment that are not authorized by Condair A/S.

Copyright Notice

© Condair A/S All rights reserved.

Technical modifications reserved

Contents

1	General information	5
1.1	Foreword	5
1.2	Health and safety	5
1.3	Hygiene	6
1.3.1	Guidelines to ensure your system stays clean and prevent the growth of Legionella	7
1.3.2	The Condair service team can help	7
1.4	Intended use	8
1.4.1	Ensure safe operation	8
1.5	Warranty	9
1.6	Delivery and storage	9
1.7	Correct method of lifting	9
1.8	Disposal	9
1.9	Inlet water – quality guide	10
2	Product overview	11
2.1	MLP RO description	11
2.2	MLP 100/300 Overview	13
2.3	MLP RO 500 overview	15
2.4	MLP RO 800 overview	18
2.5	Principal installation diagram	21
2.6	Inlet water quality requirements	22
2.7	Optional equipment for MLP RO	23
2.8	Optional equipment for MLP RO	24
2.9	MLP RO accessories list	25
2.10	Rating plate and markings	26
2.11	Electrical schematic diagrams	26
3	Installation	27
3.1	Important notes on installation	27
3.2	Positioning the pump station	30
3.3	Electrical installation	33
4	Commissioning	34
4.1	Inlet filter	35
4.2	Insert RO membrane	36
4.3	RO tank breathing filter	36
4.4	Prepare for pump flush	37
4.5	Basic set-up of the controller	38
4.6	Pump flush procedure	43
4.7	Adjusting the reverse osmosis	45
4.7.1	Water quality	46
4.7.2	Adjustment of outlet amount	47
4.7.3	Adjustment of permeate amount	48

5	Operation	49
5.1	Overview control unit	49
5.2	Equipment protection	50
5.3	Alarm messages	51
5.4	Controller menu	53
5.4.1	Alarms and user messages	54
5.4.2	Parameter change menu	55
5.4.3	Settings for section parameters	55
5.4.4	Pump	56
5.4.5	Conductivity monitoring, humidity logging and CIP (options)	57
6	Maintenance	59
6.1	Important notes on maintenance	59
6.2	Maintenance work	60
6.3	Preventive spare parts chart	62
6.4	Weekly check list	63
6.5	Troubleshooting	64
6.5.1	Malfunction with error indication	64
6.5.2	Resetting the error indication	66
6.5.3	Malfunction without error indication	67
7	Product data	68
8	Declaration of conformity	69
9	Appendices	70

1 General information

1.1 Foreword

This manual has been written to ensure the safe use, performance and longevity of the equipment, and is intended for use by engineers and properly trained technical personnel. Please read this manual thoroughly before specifying, designing or installing an ML-System from Condair A/S. Keep for future reference.

As our policy is one of continuous research and development, we reserve the right to amend, without notice, the specifications provided in this document. Condair A/S does not guarantee nor accept liability for the accuracy of information in this document.

This installation and operation manual is supplemented by various separate items of documentation (installation drawings, technical specifications etc.). Where necessary, appropriate cross-references are made to these publications in this installation and operation manual.

Guide to symbols used in this manual



CAUTION!

Instructions relating to the correct operation of the unit



WARNING!

Instructions relating to safety

1.2 Health and safety

Installation, maintenance, repair work or decommissioning should only be carried out by appropriately qualified and properly trained technical personnel. The users are responsible for ensuring their suitability. The customer is responsible for ensuring that the installation of the equipment complies with all local regulations.

Any risks or hazards relating to the system, including during installation and maintenance, should be identified by a competent health and safety representative who is responsible for introducing effective control measures.

All ideograms, signs and markings applied to the unit must be observed and kept in a readable state.

Symbols used in this manual



WARNING!

Always isolate all supplies to the system before commencing any maintenance or repair.



Due to health risks, the silicate content in the supply water – in any form – must not exceed 12 mg/l.

If the silicate content of the supply water is higher a silicate filter must mandatory be installed in the water supply line before the humidifier by the customer.

For product specific limitations for silicate please observe the required preconditions for the water supply.

1.3 Hygiene

Please observe the local health and safety executive's technical guidance on the control of Legionellosis in water systems.

The user is responsible for ensuring that the water system complies with local regulations, byelaws and guidelines (such as the HSE ACoP L8, VDI 6022, ISO 22000, HACCP or equivalent). If inadequately maintained, water systems, of which any humidifier is a part, can support the growth of microorganisms, including the bacterium that causes Legionnaires' disease.

The MLP RO is produced according to the ISO 22000 standards, which means that we have considered all aspects of this equipment to reduce the risk of Legionnaires' disease and other similar conditions. However, the user is responsible for ensuring that the installation, operation and maintenance work on the equipment is performed in a manner ensuring that the system stays clean!

Any risks or hazards relating to the system, including during installation and maintenance, should be identified by a competent health and safety representative who is responsible for introducing effective control measures.



The MLP RO must be installed, operated and maintained in accordance with this manual. Failure to do so could result in contamination that might cause Legionnaires' disease, which can be fatal.



To prevent water stagnation and microbial contamination, the MLP RO power supply should be left switched on. If the system is switched off for more than 48 hours, the pipework and system must be disinfected as per the instructions, and a full risk assessment must be undertaken to ensure safe operation.

1.3.1 Guidelines to ensure your system stays clean and prevent the growth of Legionella

- Carry out a risk assessment of the water system using a competent person, and implement an appropriate monitoring and control programme.
- Initiate procedures for checking the UV system, cleaning tanks, changing filters, disinfection etc.
- The MLP RO must be connected to a clean, potable mains water supply.
- Enter into a service contract that suits your company.
- Stop the system if polluted drinking water is found in your area.
- Avoid water temperatures between 25°C and 45°C that favour the growth of Legionella.
- Do not stop the system unless it is faulty or leaking (avoid water stagnation)
- Refrain from closing nozzles or sections, unless there is leakage or a fault (avoid water stagnation)
- Disinfect the high-pressure system at least once a year and after every maintenance or repair. Always carry out a complete system disinfection if it has been turned off for more than 48 hours
- Have water samples taken and tested for harmful bacteria at least once a year.
- Conduct follow-up measurements until the system is clean if bacteria have been detected in the system.

1.3.2 The Condair service team can help

Condair has expert technicians who can provide:

- Bacteriological troubleshooting on site *
- Cleaning and disinfecting
- Preventive maintenance
- Repair and fault finding
- Training and guidance

*Condair uses a quick method for measuring bacterial activity in the water: the approved and patented BactiQuant. Once the water sample has been taken, we can read the bacteriological quality of the water within 30 minutes, and disinfect the system if necessary.

Condair follows the guidelines in VDI 6022 for CFU counts in humidifiers. The CFU count in the humidification water must not exceed 150 CFU/ml, corresponding to a maximum BQ value of 40.

Please contact your local Condair representative for further information about our services.

1.4 Intended use

The MLP RO is intended for adiabatic humidification and cooling. Any other, or further, application is not considered use for the intended purpose. Condair A/S cannot be made liable for any damage or injury attributable to inattentive, inappropriate, negligent or incorrect operation of the equipment, whether or not caused deliberately.

Operation of the equipment in the intended manner requires that all the information in this installation and operation manual be observed (in particular the safety instructions).

Potential danger related to the MLP RO



Risk of electric shock! A person may come in contact with live parts when the pump station/control unit is open. Touching live parts may cause severe injury or death.

Prevention: Before carrying out any work on the system, disconnect power and water supply.



Poorly maintained humidification systems may be hazardous.

Prevention: read, understand and follow maintenance guidelines to ensure your system stays safe.



High pressure! The pump station delivers water at 70 bar. Inappropriately fastened hoses may be forced out of the screw connections when pressurised. Never loosen hoses or screw connections in a pressurised system.

1.4.1 Ensure safe operation

If it is suspected that safe operation has been compromised, the MLP RO should immediately be shut down and secured against accidental power-up.

Shut down the MLP RO if:

- MLP RO components are damaged, worn or very soiled.
- The MLP RO does not work correctly.
- Joints, pipes or hoses are leaking.

No modifications must be made on the MLP RO without the manufacturer's consent. All persons working with the MLP RO must report any alterations made to the MLP RO to the owner immediately.

Use only original accessories and spare parts available from your Condair representative.

1.5 Warranty

MLP RO parts are covered by a two-year warranty from the invoice date with the exception of the replacement parts listed in the routine maintenance section. Failure to observe the manufacturer's installation and maintenance recommendations and instructions will invalidate the warranty. Condair A/S cannot be made liable for damage or injury attributable to failure to observe the manufacturer's installation and maintenance recommendations and instructions.

1.6 Delivery and storage

To ensure consistent quality, each MLP RO is tested and preserved before leaving the factory. If put into storage prior to use, the MLP RO must be covered and protected from physical damage, dust, frost and rain.

It is recommended that the MLP RO be kept in its transit packaging for as long as possible prior to installation.

Inspection upon receipt: remove the transit packaging and inspect the unit to ensure that no damage has occurred during transit. Any visible damage must be reported to your Condair distributor immediately. If the unit is put into storage, the packaging should be replaced.

1.7 Correct method of lifting

Lifting or handling must only be carried out by trained and qualified personnel. Ensure that the lifting operation has been properly planned and risk-assessed, and that all equipment has been checked by a skilled and competent health and safety representative.

The customer is responsible for ensuring that operators are trained in handling heavy goods, and to enforce the relevant lifting regulations. Refer to the weights and measures section for system weight.

1.8 Disposal

You must observe local laws and regulations when disposing of your MLP RO at the end of its working life. The PAHT pump and piping is constructed from stainless steel which may be fully recycled.

1.9 Inlet water – quality guide

The quality of water being used in the MLP RO system should be checked prior to system commissioning. Condair A/S recommends that the MLP RO system be connected to a clean, potable (drinking water quality) mains water supply.

Table 1: Inlet water quality guide

Water supply	Tap water (drinking water quality) max. 150 CFU/ml (no pathogens)		
Incoming dynamic pressure at max flow	2.0 - 5 bar / 30 - 75 PSI		
Min. flow requirement at min dynamic pressure	Permeate + Concentrate + 10 %		
Min flow MLP RO 100	200 l/hr at 2.5 - 7 bar (dynamic)		
Min flow MLP RO 300	600 l/hr at 2.5 - 7 bar (dynamic)		
Min flow MLP RO 500 with water softener	700 l/hr at 2.5 - 7 bar (dynamic)		
Min flow MLP RO 800 with water softener	1100 l/hr at 2.5 - 7 bar (dynamic)		
Water temperature *	10 - 20 °C (50 - 68 °F), max. 15 °C recommended		
pH max in incoming water *	8.0		
	pH in incoming water		
	pH 6.5 - 7.0	pH 7.1 - 7.5	pH 7.6 - 8.0
Max. hardness at incoming pH *	30 °dH (31 gpg)	17 °dH (18 gpg)	10 °dH (10 gpg)
Max. conductivity at incoming pH *	1300 µS/cm	750 µS/cm	440 µS/cm
Max. TDS at incoming pH *	800 mg/l	500 mg/l	375 mg/l
Silt index	max. 3		
Silicates in any form	max. 3 mg/l		
KMnO ₄	max. 10 mg/l		
SiO ₂	max. 1 mg/l		
Fe	max. 0.2 mg/l		
Mn	max. 0.05 mg/l		
NTU	max. 1.0		
Free chlorine	max. 0.1 mg/l		

* if any of these values are higher, a water softener should be installed in front of the reverse osmosis device

Water monitoring

The MLP RO water system must be monitored for hygiene as part of the maintenance programme. Please refer to the maintenance section for further guidance.

Disinfection

Depending on the system hygiene, it is advised that preventative disinfection fluid be added to the MLP RO water tank at an appropriate frequency, but at least once a year.

Condair A/S recommends adding the disinfection fluid SANOSIL S010 AG 5% (our code: 155404000) to the tank, desired concentration 0.1%. SANOSIL is safe, non-toxic and eco-friendly which provides a prophylactic, disinfection dose and is effective against all types of microorganisms, including Legionella and E.coli.

Please read the Maintenance section for more information on disinfection.

If you are in any doubt about the suitability of water quality, please contact your Condair distributor who will be happy to support you.

2 Product overview

2.1 MLP RO description

The MLP RO series is a combined high-pressure pump station and reverse osmosis system (from now on called RO). The combined system is developed by Condair A/S with focus on reliable and hygienic humidification solutions. The system is fitted with an integrated reverse osmosis system and tank for removal (>95%) of salts and minerals in tap water.

The MLP RO comes in four basic models, MLP RO 100, 300, 500 and 800. The number indicates the maximum continuous water outlet (high-pressure) in l/h @ 15°C (tap water temperature).

There are two or three pumps on the frame: The RO pump which pumps the raw water through the RO membrane at a pressure of 8-12 bar and into the RO water tank, the high-pressure pump that feeds from the bottom of the RO tank and discharges at 70 bar, and (optional or MLP RO 800 always) a RO water transfer pump.

MLP RO's are fitted on 'easy-to-place' frames and all components are assembled, tested and ready for use.

All components exposed to water are made of corrosion-resistant material. All hoses are steel-reinforced and drinking water-approved.

Both the high-pressure and RO pumps are directly mounted on their electric motors. Power is supplied to 3-phase asynchronous motors via a magnet-operated protective motor switch.

The high-pressure pump is protected against dry running by the level sensor in the RO tank that stops the system if water level drops. The high-pressure pump is protected against overheating by a temperature sensor that measures the temperature inside the pump.

A pressure switch just after the inlet filter protects the RO pump from dry running.

The MLP RO 100 and 300 has 50 l holding tanks for the produced RO water, mounted directly on the pump frame where the holding tanks of MLP RO 500 and 800 are placed on separate frames (200 l and 500 l). On the MLP RO 100, 300 and 500 models, the high-pressure pump feeds directly from the holding tanks using gravity whereas the MLP RO 800 has a booster pump for pumping RO water from the RO holding tank to the high-pressure pump.



Fig. 1: MLP RO Models

The control unit consists of a touch display and a PLC mounted in the IP 65-rated electrical cabinet as well as a power board for control of the high-pressure pump and connection terminals for power supply (208...480V/3N~/50-60Hz).

From the touch screen, the operator can easily change humidity set point in each section, adjust alarm limits and view hour counters, logged alarms, trend curves, etc.

The pump station is electrically wired at the factory. At the installation site, main power supply, humidity signal, external safety chain, step valves and additional options must be electrically connected to the control unit.

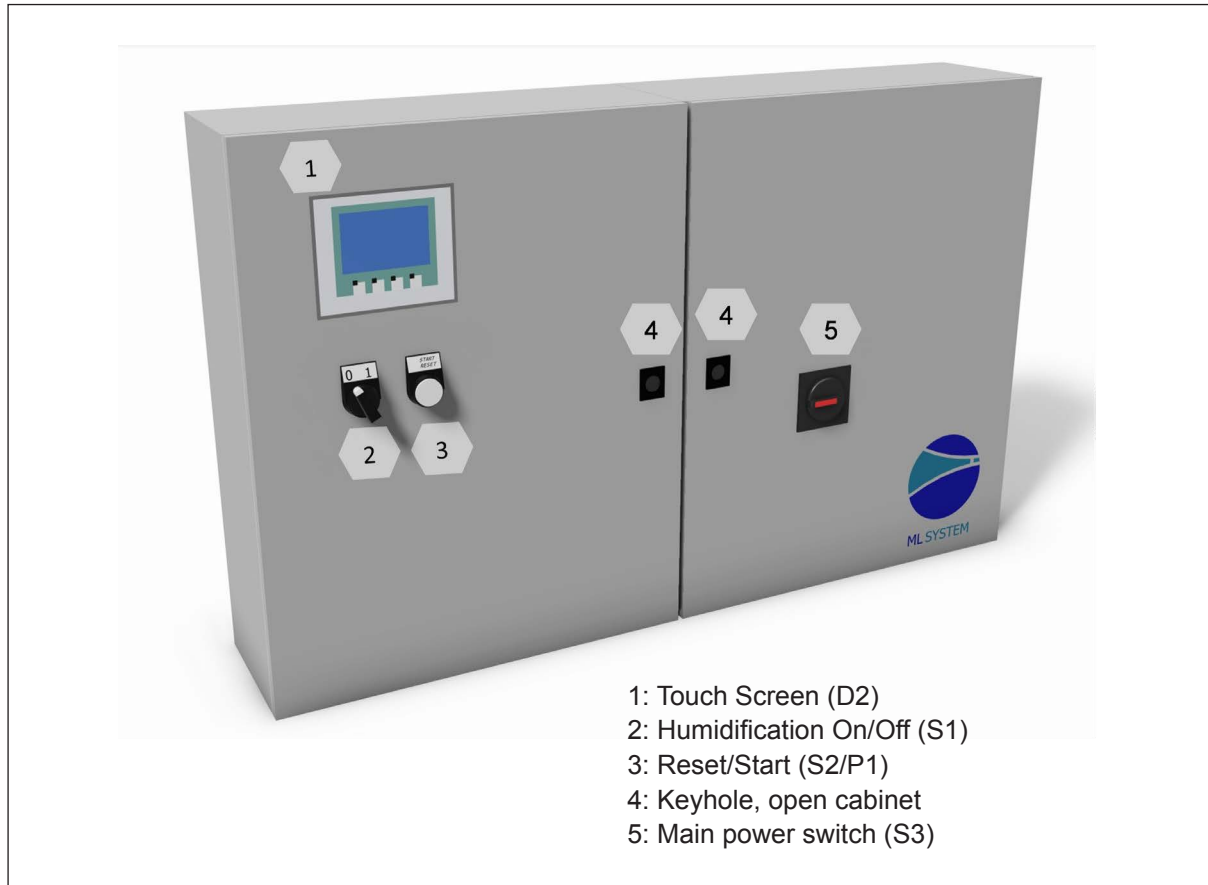

Fig. 2: Control unit

2.2 MLP 100/300 Overview

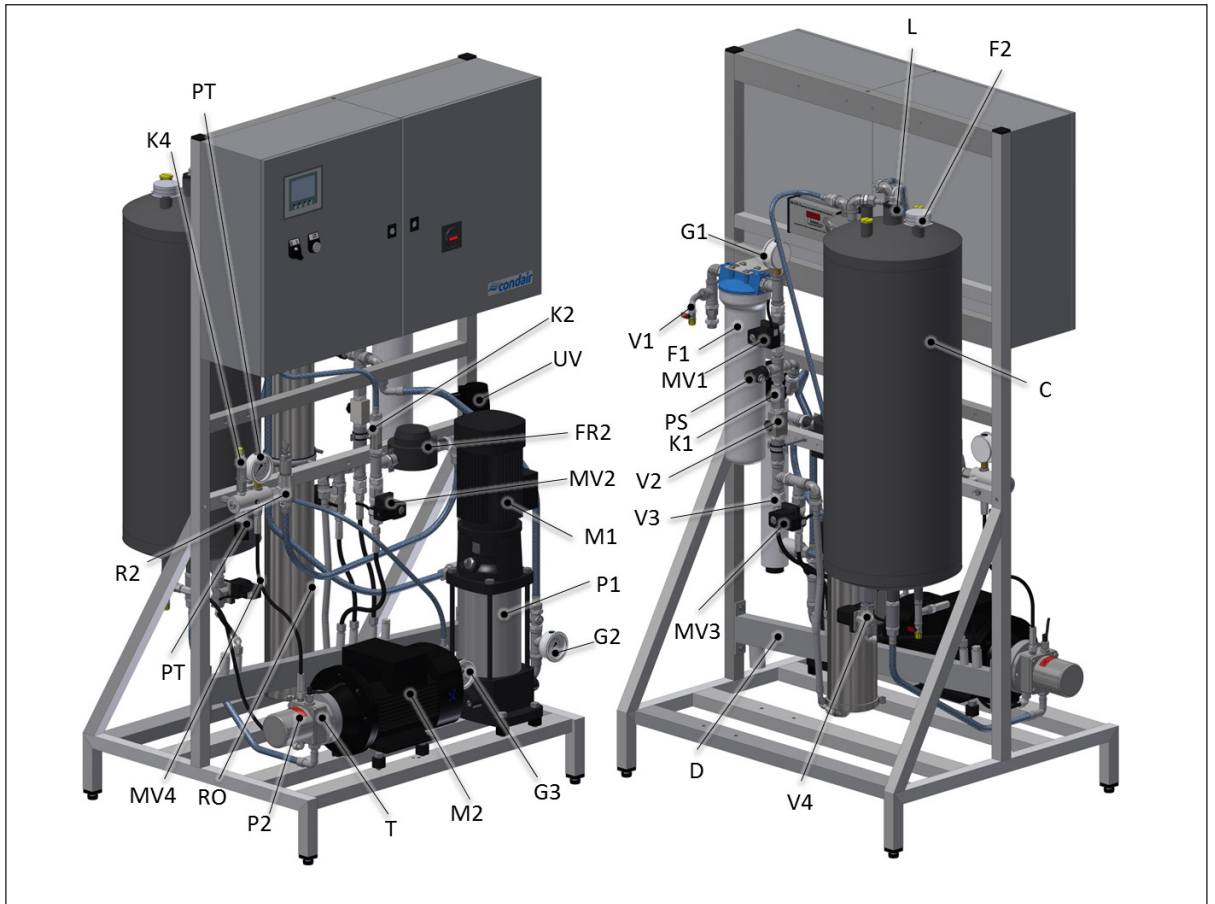

Fig. 3: MLP 100/300 Overview

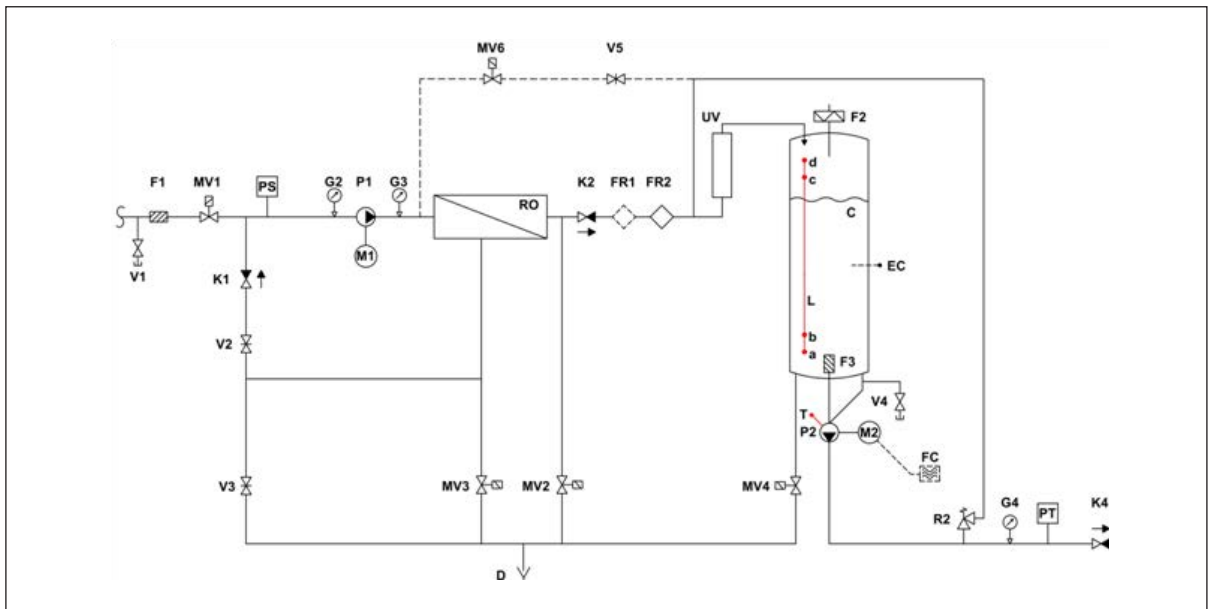

Fig. 4: Hydraulic diagram MLP 100/300

Table 2: Legend MLP RO 100/300 Overview

C		Permeate tank, 55 L, black plastic
D		Discharge system
EC	(Option)	Conductivity sensor
F1		Filter 20", 5 µm
F2		Sterile breathing filter 0.2 µm
F3		Filter
FC	(Option)	Frequency converter
FR1	(Option)	Permeate - flow meter, GF
FR2		Water meter for permeate, plastic M25
G2		Pressure gauge, input pressure RO pump 0-10 bar
G3		Pressure gauge, RO pump pressure 0-10 bar
G4		Pressure gauge, high-pressure 0-160 bar
K1		Check valve
K2		Check valve
K4		Check valve
L		ML level sensor: a) Empty b) Start level c) Full d) Overflow
M1		Motor, RO pump
M2		Motor, high-pressure pump
MV1		ON/OFF valve 1/2" 0-10 bar
MV2		Valve for flushing at start-up
MV3		Valve for membrane flushing
MV4		Drain valve
MV6	(Option)	Valve for conductivity control
PS		Pressure switch 0-10 bar, pre-adjusted to 0.5 bar
P1		RO pump
P2		PAH high-pressure pump 70 bar
PT	(Option)	Pressure transmitter 0-100 bar (always with VFD option)
RO		RO membrane in stainless steel housing
R2		Pressure regulator, 30-105 bar standard
T		Thermostat
UV		UV system
V1		Test water tap 1/8"
V2		Needle valve for pressure adjustment 1/2"
V3		Nozzle for concentrate flow
V4		Test water tap 1/8"
V5	(Option)	Needle valve or nozzle for conductivity control

2.3 MLP RO 500 overview

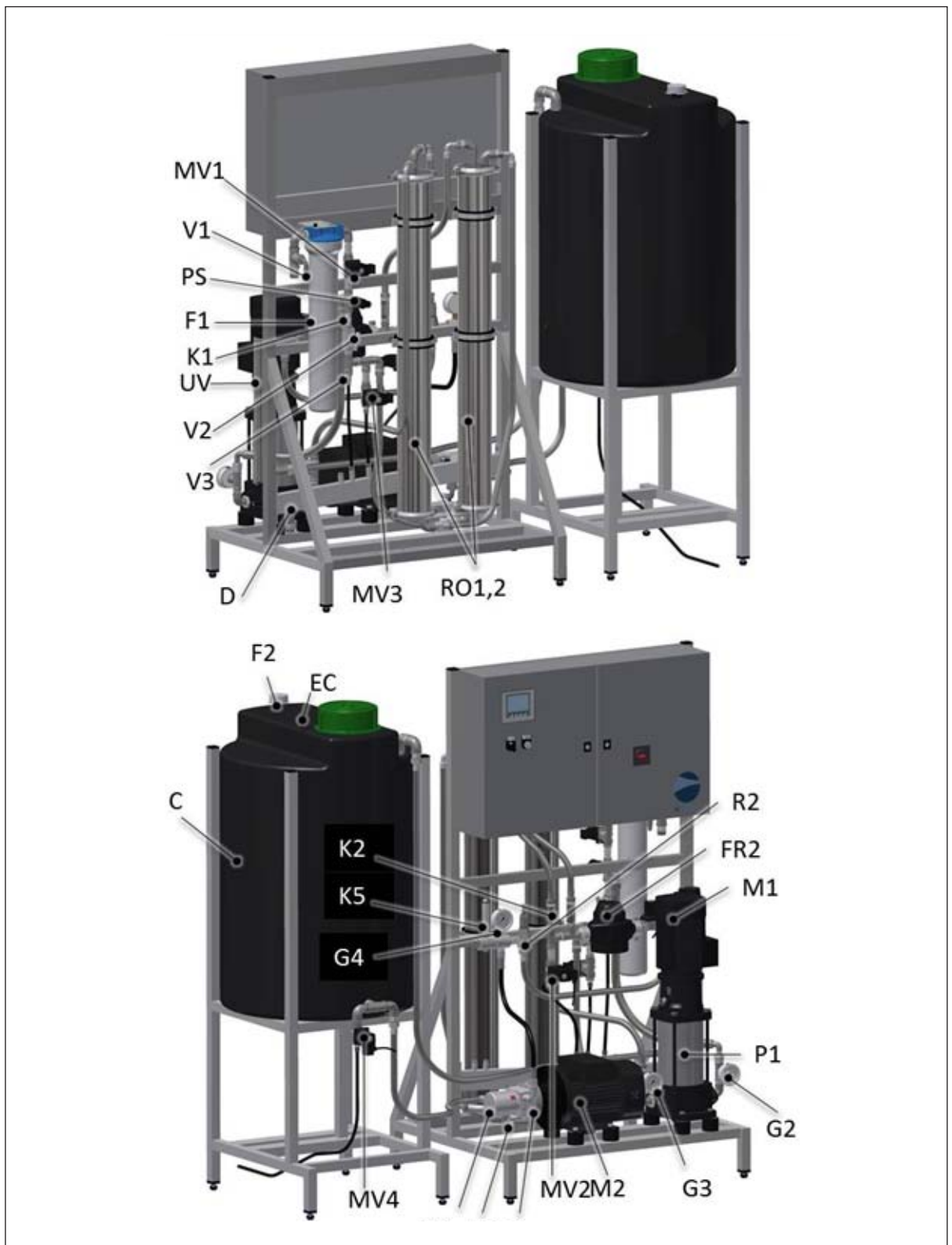

Fig. 5: MLP RO 500 Overview

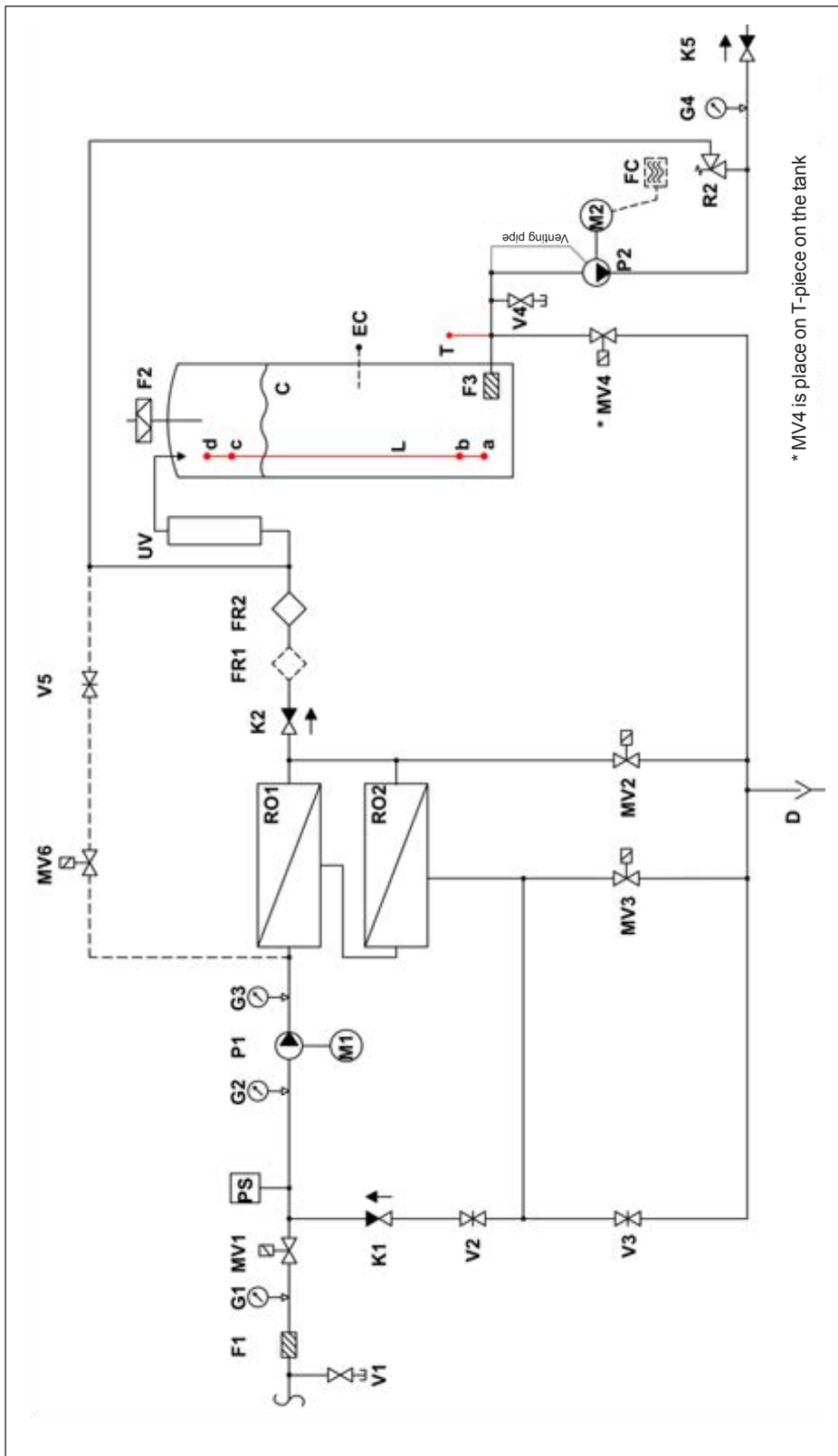

Fig. 6: Hydraulic diagram MLP RO 500

Table 3: Legend MLP RO 500 Overview

C		Permeate tank, 200L, black plastic
D		Discharge system
EC	(Option)	Conductivity sensor
F1		Filter 20", 5 µm
F2		Sterile breathing filter 0.2 µm
F3		Filter
FC	(Option)	Frequency converter
FR1	(Option)	Permeate - flow meter, GF
FR2		Water meter for permeate, plastic M25
G2		Pressure gauge, input pressure RO pump 0-10 bar
G3		Pressure gauge, RO pump pressure 0-10 bar
G4		Pressure gauge, high-pressure 0-160 bar
K1		Check valve
K2		Check valve
K4		Check valve
L		ML level sensor: a) Empty b) Start level c) Full d) Overflow
M1		Motor, RO pump
M2		Motor, high-pressure pump
MV1		ON/OFF valve 1/2" 0-10 bar
MV2		Valve for flushing at start-up
MV3		Valve for membrane flushing
MV4		Drain valve
MV6	(Option)	Valve for conductivity regulating
PS		Pressure switch 0-10 bar, pre-adjusted to 0.5 bar
P1		RO pump
P2		PAH high-pressure pump 70 bar
PT	(Option)	Pressure transmitter 0-100 bar (always with VFD option)
RO1,2		2 RO membranes in stainless steel housing
R1		Pressure reduction valve
R2		Pressure regulator, 30-105 bar standard
T		Thermostat
UV		UV system
V1		Test water tap 1/8"
V2		Needle valve for pressure adjustment 1/2"
V3		Nozzle for concentrate flow
V4		Test water tap 1/8"
V5	(Option)	Needle valve or nozzle for conductivity control

2.4 MLP RO 800 overview

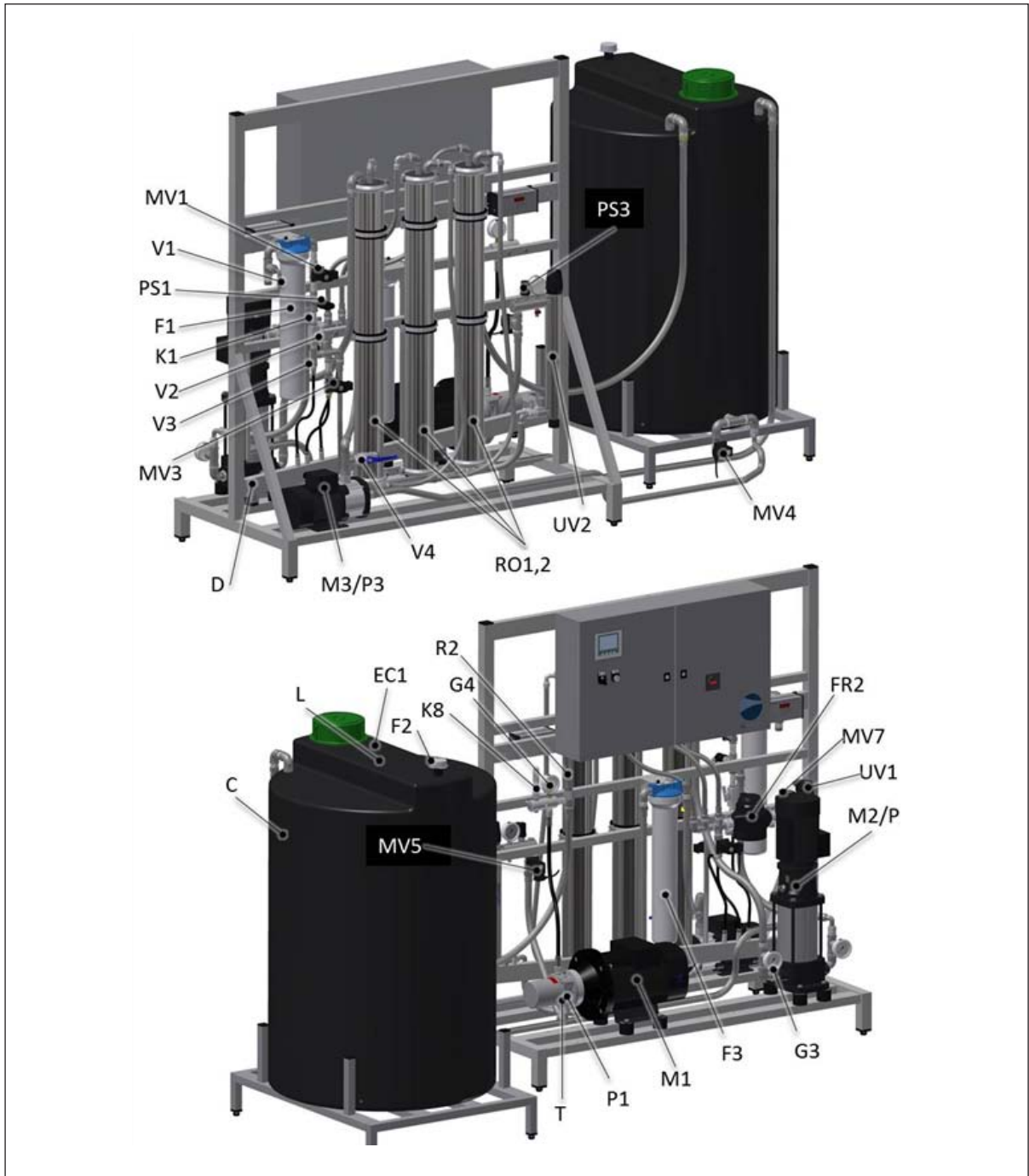

Fig. 7: MLP RO 800 Overview

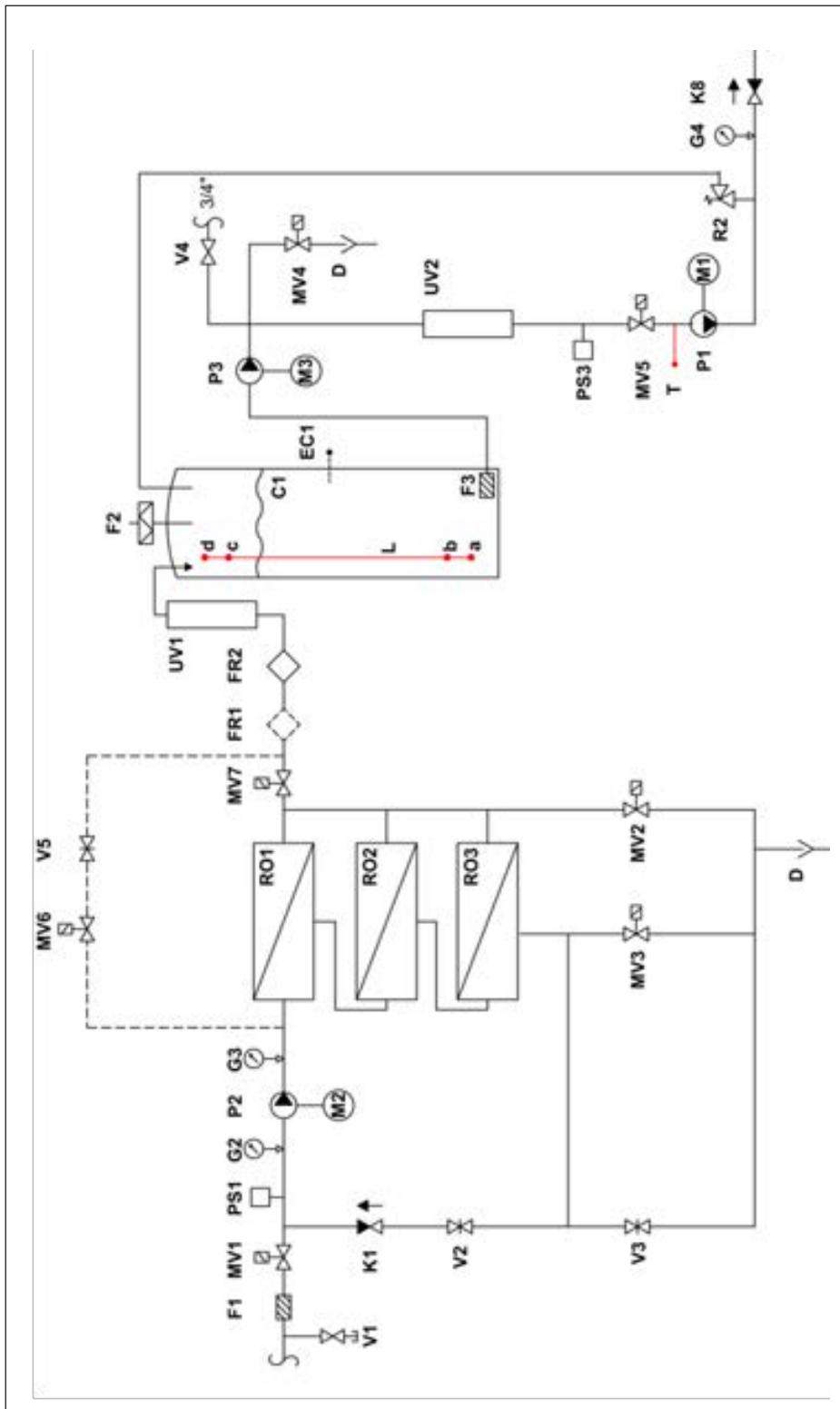

Fig. 8: Hydraulic diagram MLP RO 800

Table 4: Legend MLP RO 800 Overview

C		Permeate tank 500 l, black plastic
D		Drainage system
EC1	(Option)	Conductivity sensor
F1		Filter 20", 5 µm
F2		Sterile breathing filter 1/4", 0,2 µm
F3		Filter 20", 1 µm
FR1	(Option)	Water meter for permeate, plastic M25 (GF-type)
FR2		Water meter for permeate, plastic M25
G2		Pressure gauge, input pressure RO Pump 0-10 bar
G3		Pressure gauge, RO pump pressure 0-25 bar
G4		Pressure gauge, high-pressure
K1		Check valve
K8		Check valve
L		ML level sensor: a) Empty b) Start level c) Full d) Overflow
M1		Motor, high-pressure pump
M2/P2		RO pump
M3/P3		Booster pump
MV1		ON/OFF valve 1/2"
MV2		Valve for flushing at start-up, 3/4"
MV3		Valve for membrane flushing 1/2"
MV4		ON/OFF valve 1/2" for by-pass. 50 l/h
MV5		ON/OFF Valve 1/2"
MV6		Valve for conductivity control
MV7	(Option)	ON/OFF valve 1/2",
P1		PAH 10 high-pressure pump 70 bar
PS1		Pressure switch 0-10 bar, pre-adjusted to 0.5 bar
PS3		Pressure switch 0-10 bar, pre-adjusted to 0.5 bar
RO1-3	(Option)	3 RO membranes in stainless steel housing
R2		Pressure regulator, 30-105 bar
T		Thermostat
UV1		UV system
UV2		UV system
V1		Test water tap 1/8"
V2		Needle valve for pressure adjustment 1/2"
V3		Nozzle for concentrate flow
V4		Shut-off valve
V5	(Option)	Needle valve or nozzle for conductivity control

2.5 Principal installation diagram

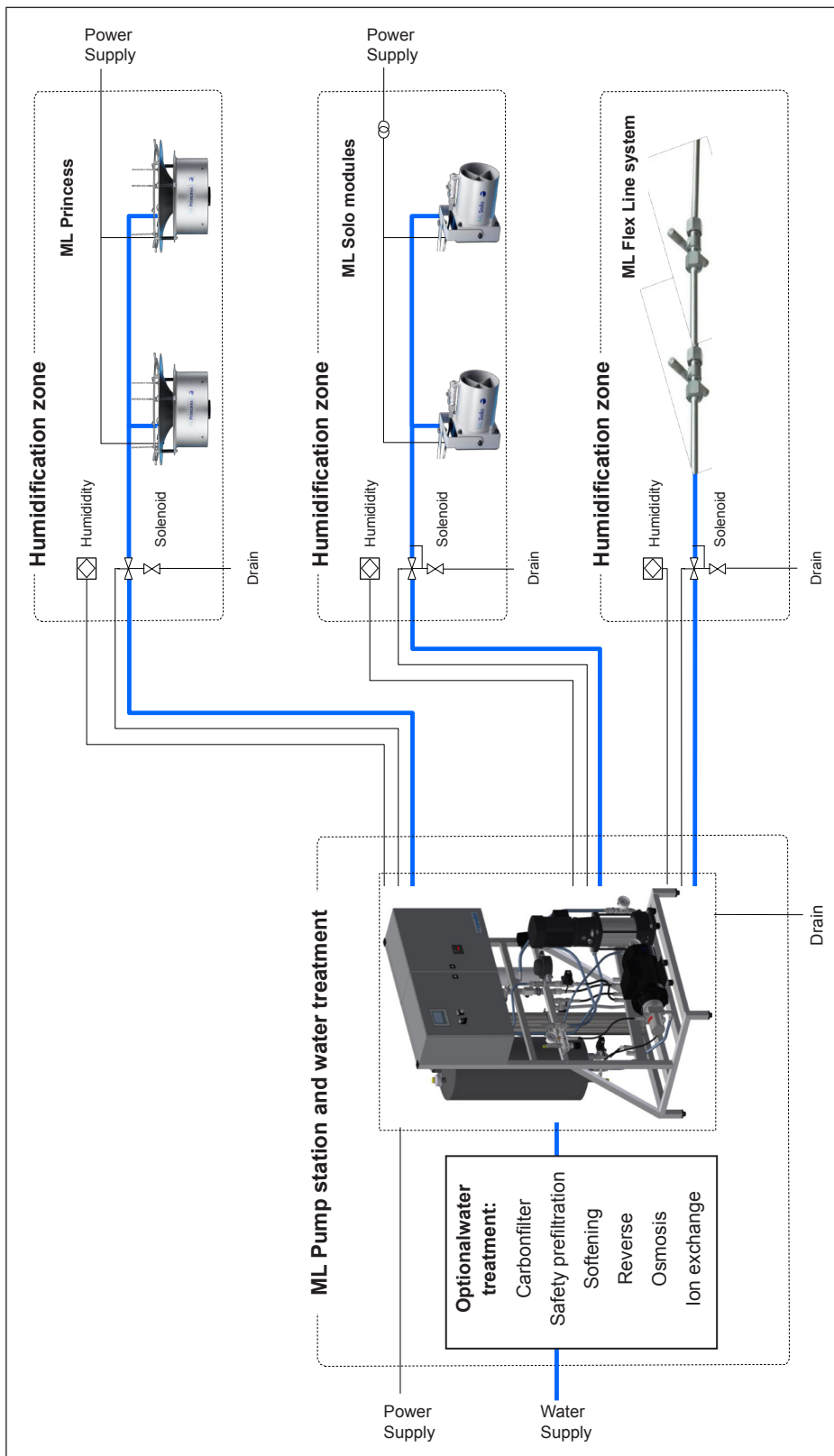

Fig. 9: Principal installation diagram

2.6 Inlet water quality requirements

The quality of the water being used in the MLP RO system should be checked prior to system commissioning. Condair A/S recommends that the MLP RO system be connected to a clean, potable (drinking water quality) mains water supply. If the inlet water does not meet the quality specified in the preconditions table, it may be necessary to install additional water treatment.

Table 5: Inlet water quality requirements

Water supply	Tap water (drinking water quality) max. 150 CFU/ml (no pathogens)		
Incoming dynamic pressure at max flow	2.0 - 5 bar / 30 - 75 PSI		
Min. flow requirement at min dynamic pressure	Permeate + Concentrate + 10 %		
Min flow MLP RO 100	200 l/hr at 2.5 - 7 bar (dynamic)		
Min flow MLP RO 300	600 l/hr at 2.5 - 7 bar (dynamic)		
Min flow MLP RO 500 with water softener	700 l/hr at 2.5 - 7 bar (dynamic)		
Min flow MLP RO 800 with water softener	1100 l/hr at 2.5 - 7 bar (dynamic)		
Water temperature *	10 - 20 °C (50 - 68 °F), max. 15 °C recommended		
pH max in incoming water *	8.0		
	pH in incoming water		
	pH 6.5 - 7.0	pH 7.1 - 7.5	pH 7.6 - 8.0
Max. hardness at incoming pH *	30 °dH (31 gpg)	17 °dH (18 gpg)	10 °dH (10 gpg)
Max. conductivity at incoming pH *	1300 µS/cm	750 µS/cm	440 µS/cm
Max. TDS at incoming pH *	800 mg/l	500 mg/l	375 mg/l
Silt index	max. 3		
Silicates in any form	max. 3 mg/l		
KMnO ₄	max. 10 mg/l		
SiO ₂	max. 1 mg/l		
Fe	max. 0.2 mg/l		
Mn	max. 0.05 mg/l		
NTU	max. 1.0		
Free chlorine	max. 0.1 mg/l		

* if any of these values are higher, a water softener should be installed in front of the reverse osmosis device

2.7 Optional equipment for MLP RO

Choosing the right water treatment is essential for successful humidification. In the ML-System programme, there is a large variety of water treatment and optional equipment to choose from. The ML-System is designed to be customised to meet the specifications, be it essential water treatment or features. It is possible to combine ML-Systems, water treatment and optional equipment in more than 100,000 different combinations and it is thus impossible to describe all of them here. In the following, the most commonly used ancillary and optional equipment for the MLP RO system is listed.

Optional and ancillary equipment can be divided into the three following main groups:

MLP RO options: Added features which are intergraded into the controller of the MLP RO or placed on its frame, e.g. conductivity and hardness alarm, BAS integration, ultra-pure water (mixed bed), CIP system, CO₂ adding, damping water outlet, holding tanks (RTN). Options cannot be retrofitted and must therefore be listed when ordering

Water treatment: Stand-alone systems for improving the water quality in order to meet the inlet water quality requirements for the MLP RO, e.g. booster pump, non-return valve, silt/pre-filter, carbon filter and softener. See separate Water treatment / RO manual for further information.

High-pressure building installation: Added features and optional equipment – e.g. fan speed controller, flow monitor, temperature read-out. Options for the high-pressure building installation will be described in the I/O manual for the high-pressure building installation. See separate High-pressure equipment manual for further information.

2.8 Optional equipment for MLP RO

Options cannot be retrofitted and must therefore be listed in connection with order placement.

Table 6: Optional equipment for MLP RO

Fan control (Prepare of the control board)	Prepares the control board with terminals I/O for connecting a fan control box.
Fan control box (1-4 zones)	Start/stop fans in each zone between humidification cycles. Only possible if the control board has been prepared for the accessory.
ML EC REG 1 Conductivity sensor (in RO tank)	Measuring the conductivity (γ S) of the RO water in the RO tank, incl. Hi/Low alarms.
ML EC REG 1 Preparatory	Not incl. sensor, amplifier, sensor cable or fittings.
ML EC-REG 2 (inlet water mixer)	Mixes inlet water in the produced water from the RO membrane in order to raise the conductivity of the ROwater
ML EC-REG 6 (CO ₂ mixer) For new systems 50-200 l RO-tanks / 500-1,000 l RO tanks	Mixes CO ₂ in the produced water from the RO membrane in order to increase ROwater conductivity. CO ₂ tanks are not included.
Mixed bed, preparation for(mixed bed filters not included)	Prepares the pump station with pipe connections and the control board with terminals I/O for connecting a mixed bed filter system that produces ultra-pure water from the RO water.
RO water outlet MLP RO 100 – 500 / MLP RO 800	Delivers pressurised RO water @ 3 bar, volume depending on RO size and operation factor.
Overheating protection of the high-pressure pump(flow/temp-dependent)	Dumps excess water via a solenoid valve if the temperature or flow through the pump comes outside the permissible limit.
CIP (clean-in-place) new systems up to 300 l/h / up to 800 l/h	Integrated function in controller, that adds of a small amount of disinfection into the water circuit, to prevent bacterial growth.
PLC webserver access	Access to the PLC's homepage from a standard browser. Displays the operating status and humidity for each zone.
Humidity logger	Logs the humidity in each zone every 15 minutes (1 year back). Data is stored in a .csv comma-separated values file, which can be accessed on a SD card or the PLC'swebserver.
BAS/BMS integration Modbus TCP/IP	Displays the operating humidity and alarm status of the system via a TPC/IP protocol.
Backup high-pressure pump	The pump station is fitted with an extra high-pressure pump for redundancy, automatic changeover.
Status relay	Potential-free relays (ready, running, warning, error).
Hardness alarm	Shuts down pump station or triggers an alarm if the hardness of the incoming water exceeds the selected limit.
Pulse generator for water meter	The water meter is equipped with a pulse emitter which can be linked to tele-reading systems, the PLC and to M-Bus networks.

2.9 MLP RO accessories list

Accessories can be retrofitted.

Table 7: MLP RO accessories list

Pulse generator for water meter, retrofit kit	The water meter is equipped with a pulse emitter which can be linked to tele-reading systems, the PLC and to M-Bus networks.
ML control box for induct system	ML satellite unit for connecting and controlling an induct system from an MLP or an MLP RO pump station.
Satellite box (4 zones)	Ads 4 additional zones (humidity I/O and zone valve terminals) to an existing ML-System.
Satellite box (8 zones)	Ads 8 additional zones (humidity I/O and zone valve terminals) to an existing ML-System.
Humidity logger retrofit kit	Logs the humidity in each zone every 15th minute one year back. Data is stored in a .csv comma-separated values file which can be accessed on an SD card or the PLC's webserver.
RO water outlet, Retrofit kit	Delivers pressurised RO water @ 3 bar volume depending on RO size and operation factor.
Alarm lamp	Alarm flash which can be placed up to 100 m from the pump, connects to an alarm output.
Modbus TCP/IP Gateway IP translator	Easy setup op Modbus TCP/IP communication to BAS as IP addresses can be chosen by the costumer onsite.
Remote alarm SMS	Sends a SMS via a prepay SIM-card if the system goes in alarm and when the alarm is cancelled.
Remote alarm email	Sends an email if an alarm is triggered in the system and when the alarm is cancelled. Up to 25 recipients.
BAS/BMS integration Modbus TCP/IP, retrofit kit	Displays the operating humidity and alarm status of the system via a TPC/IP protocol.

2.10 Rating plate and markings

The rating plate is placed in the upper left corner on the side of the control unit (when facing the front).



Fig. 10: Rating plate

A label with the internal order number and electrical schematic diagram number is placed on the inside of the left-hand cabinet hatch (when facing the front) on the control unit.

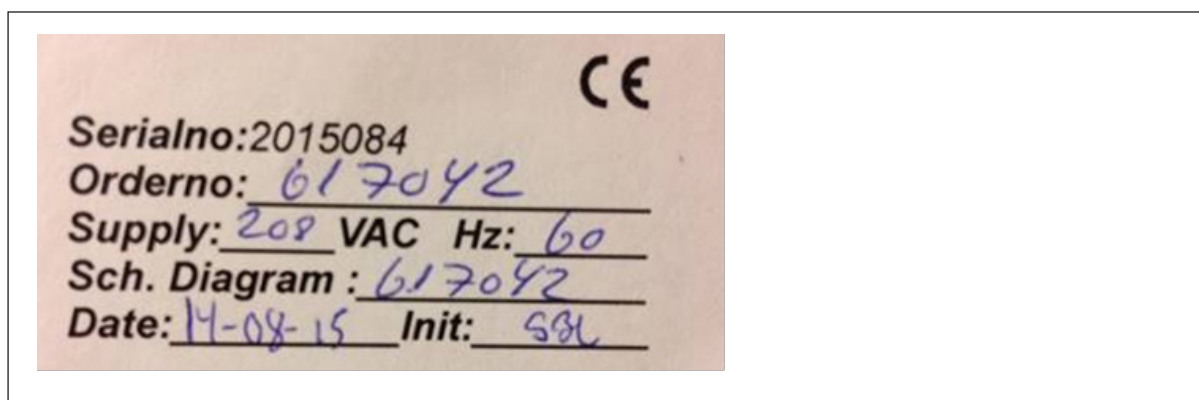

Fig. 11: Label with the internal order number and electrical schematic diagram number

2.11 Electrical schematic diagrams

A copy of the electrical schematic diagrams is placed on the backside of the hatch inside the control panel.

3 Installation

3.1 Important notes on installation

Qualification of personnel

All installation work must be performed only by persons familiar with the ML-System pump station and sufficiently qualified for such work. All work on electric installations must only be performed by adequately qualified electricians.

Safety

The pump station and any control units may only be connected to the mains after all installation work has been completed. All statements relating to correct positioning and installation must be followed and complied with. When installing components of the MLP RO, use the materials and hoses supplied with the unit. In case of doubt, please contact your Condair supplier.



WARNING!

Do not retighten/unscrew hoses while the system is pressurised!



CAUTION!

Do not use oil, grease, glue, Teflon, silicon, O-ring lubrication, etc. when assembling pipes or hose connections.

All of the above products can act as food for bacteria and are thus pose health risks.

Only approved lubricant: Dish soap.

Wash your hands before or wear clean gloves while assembling parts in direct contact with water. Keep dust covers on pipes and hoses until just before assembly.



CAUTION!

Do not fasten the pump station or hoses/pipes to vibrating installations.

Tools needed for installation work

- Screwdriver set
- Bubble level
- Polygrip pliers
- Wire cutters
- Spanner set
- Tape measure
- Marker
- Box cutter

Please observe the following on positioning and installation:

- The pump station must be installed only in a location with a drain in the floor.
- The site must be freely accessible with sufficient space for convenient operation and maintenance (min. free space around pump station: laterally 0.5 m, 0.8 m front / back).
- The pump station is designed for operation in a frost-free and dry environment, never outdoors.
- Do not install the pump station in exposed locations or locations with heavy dust loads.
- The pump station is designed for installation on a load-bearing floor.

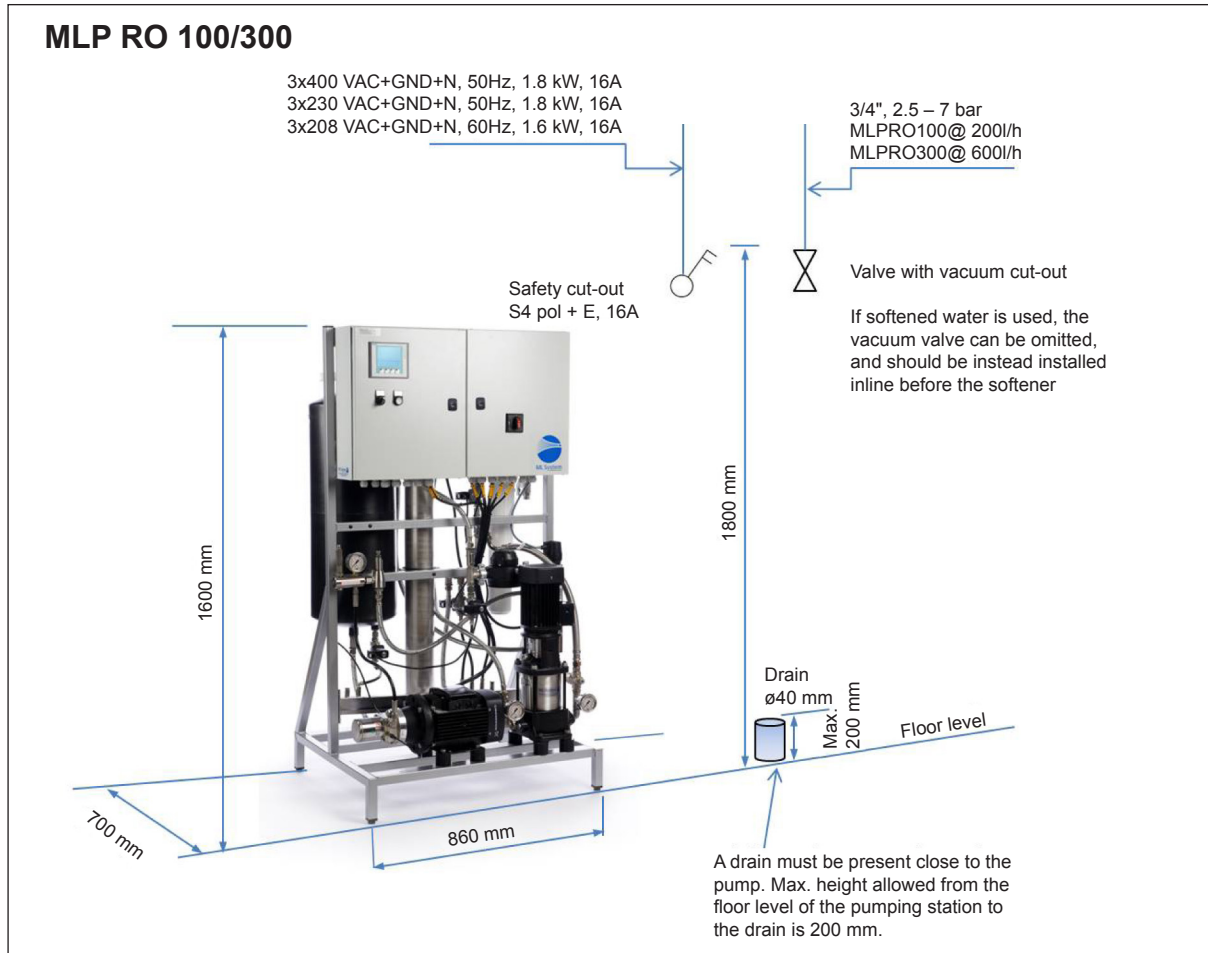

Fig. 12: Positioning MLP RO 100/300

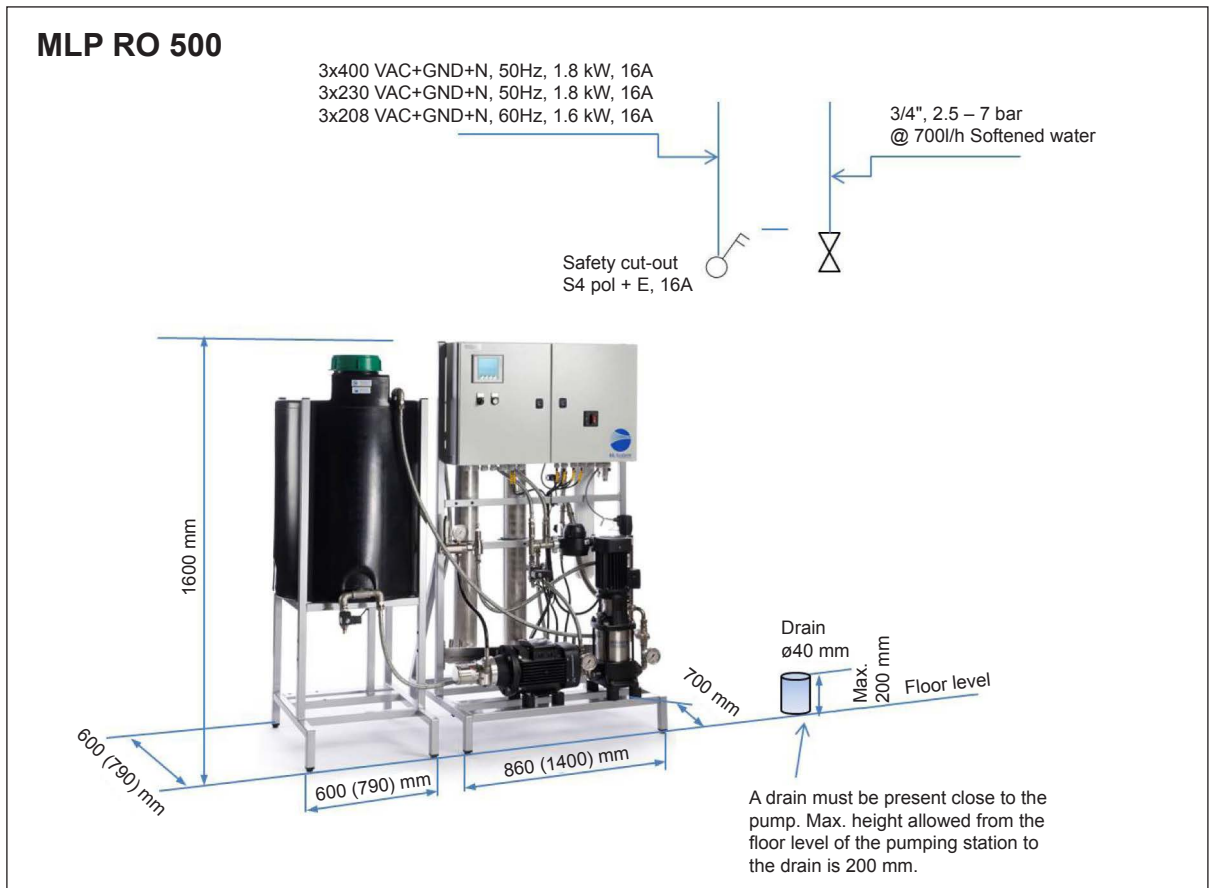

Fig. 13: Positioning MLP RO 500

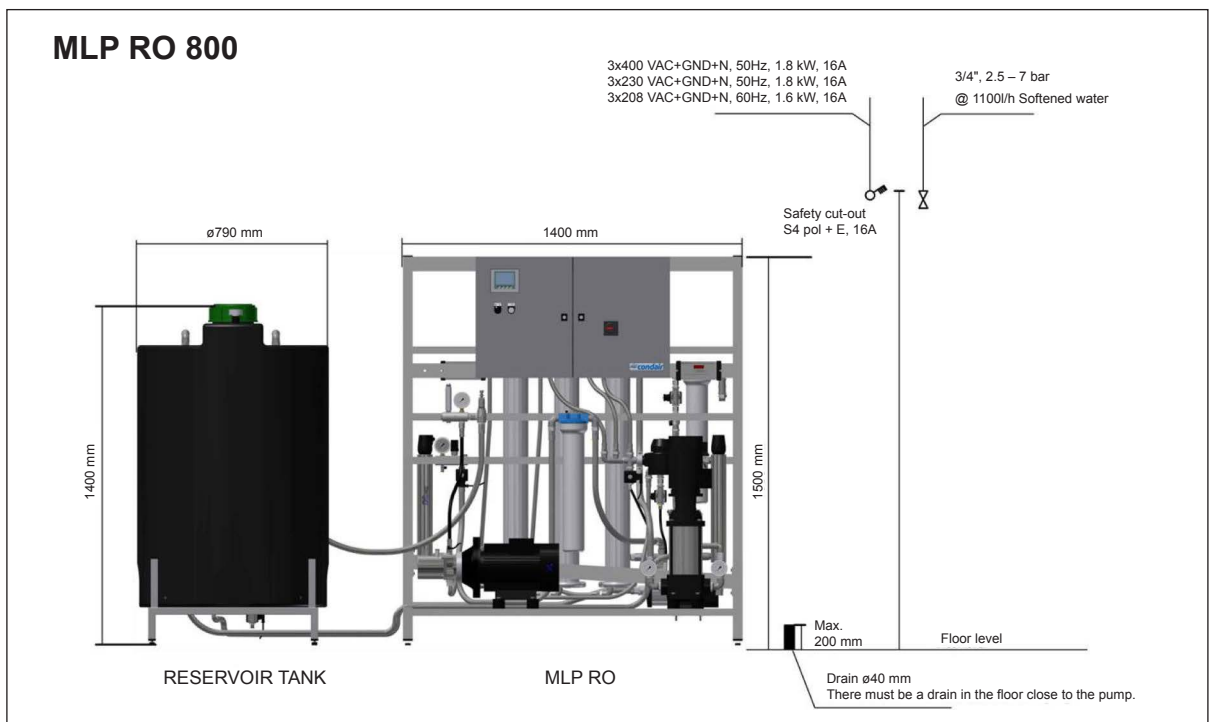

Fig. 14: Positioning MLP RO 800

3.2 Positioning the pump station

Before positioning the MLP RO pump and tank, it is important to consider the position of water treatment equipment in the room prior to installing the MLP RO and high-pressure unit.

The water treatment installation parts should be installed in the order shown in the figure below. Please note that the combination of water treatment systems will vary from one installation to the next due as a result of water quality and regulatory requirements in the given location.

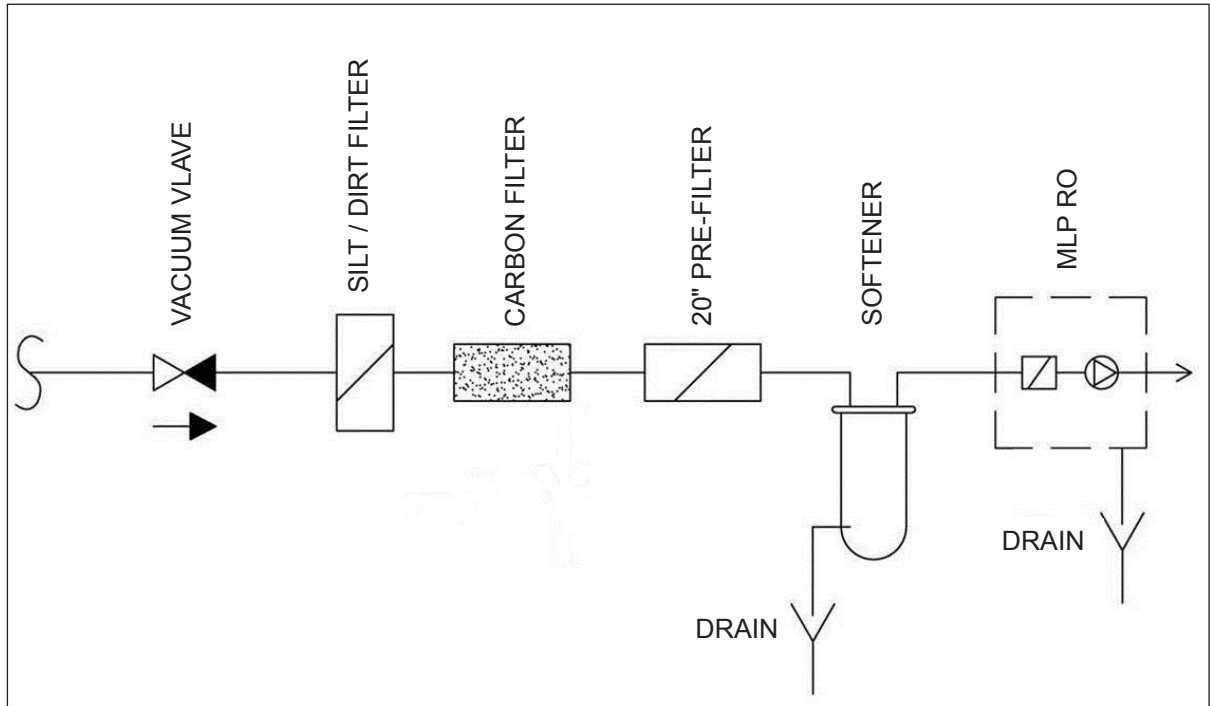

Fig. 15: Positioning water treatment equipment

Start by examining the types of water treatment systems to be installed and read their installation instructions as regards location and any requirements for supply and drainage.

Mark the location of the different systems in the room and note any missing supply or drains for the systems. Make sure you have the necessary fixing equipment available: cable ties, cable trays, screws and wall anchors.

Place the MLP RO on a hard floor with a drain

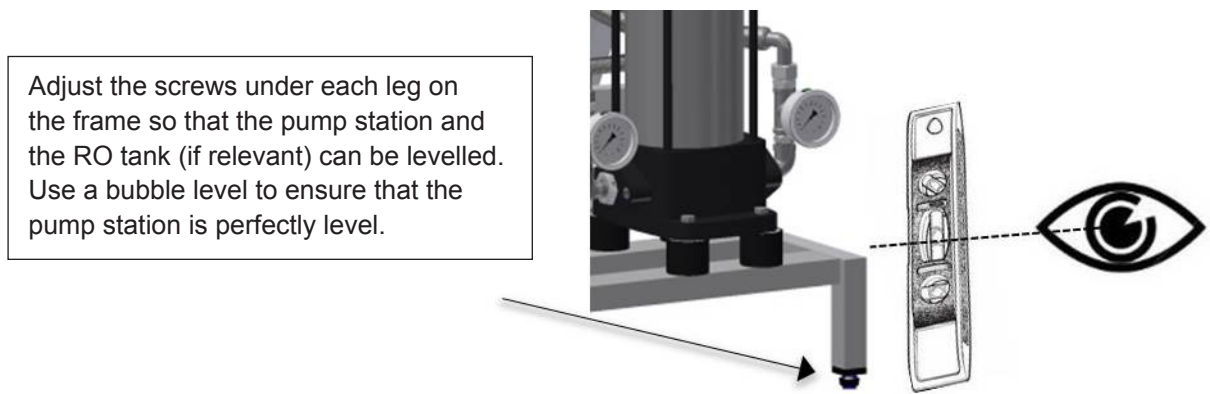
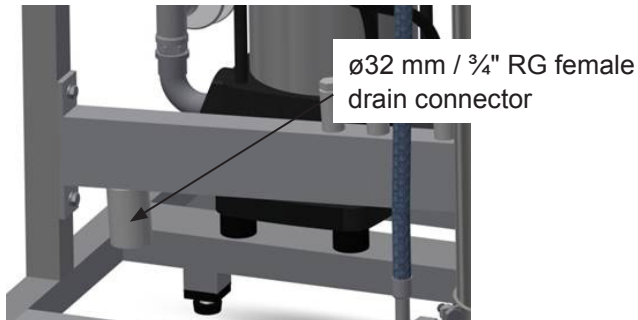

Fig. 16: Adjusting the pump station

Drain

Connect the MLP RO to the floor drain with a tube or hose of a ¾" RG female in the drain connector. On MLP RO 500 and 800, the drain from MV4 on the RO tank must also be led to a drain – either directly or be connected to the drain connector D.



- Remove protecting plug (yellow) from drain connector.
- Connect drain hose to water outlet connector (ø32 mm) and lead the drain hose down to an open funnel with a constant down-slope.
- Fix drain hose in its position, so it cannot move during operation.

The drain must have an appropriate down-slope to allow the water to flow freely and without pressure from the drain connector

Water connection



WARNING!

Do not open and fill hoses, pumps, filters or tanks with water if the system is not to be started immediately after installation (48 hours). Stagnant water acts as a breeding ground for potentially dangerous micro-organisms.

Before connecting the MLP RO to the water supply of the building or the water treatment system, it must be ensured that the incoming water is as clean as possible. This is done by running a hose from the supply to the drain and open the shut-off valve completely. Let the water run for at least ten minutes. Shut off the water again and connect MLP RO to the water supply with the supplied hose (3/4", 1.5 m).

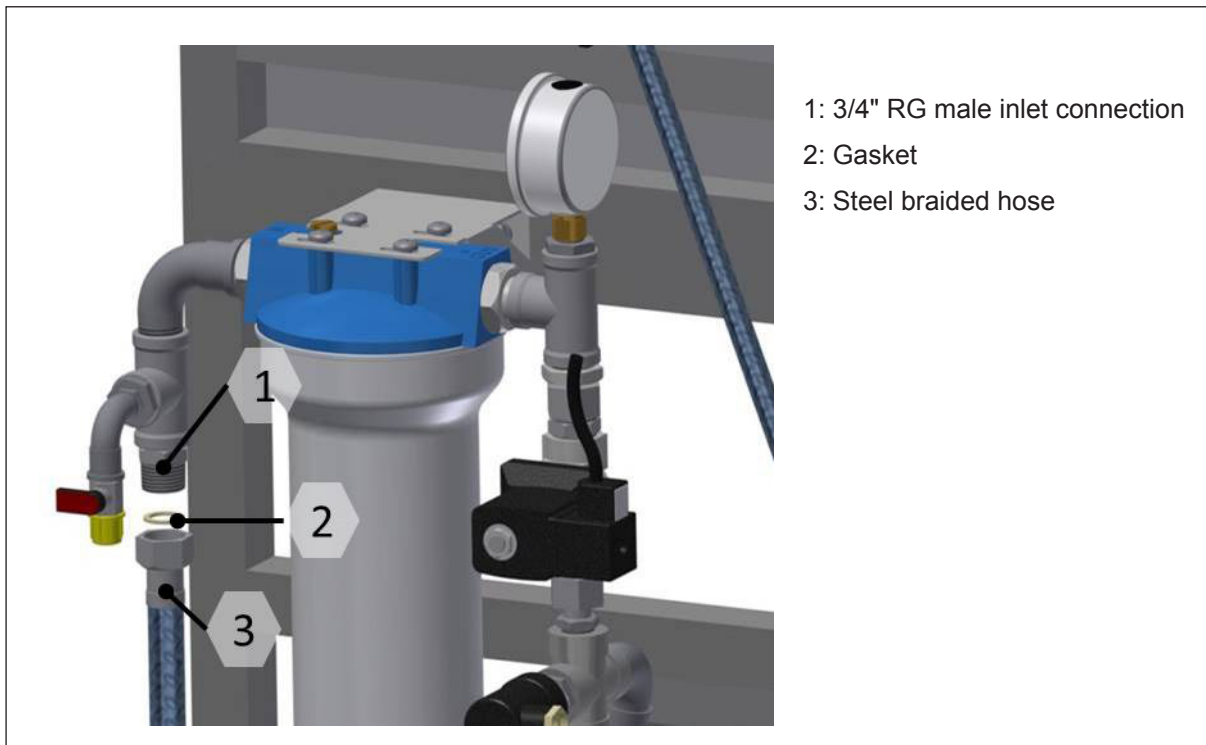

Fig. 17: Water connection

On MLP RO 500 and 800, the separate RO tank must also be connected to the pump station.

MLP RO 500, two connections: F3 to P2 and UV to C

MLP RO 800, three connections: F3 to P3, R2 to C and UV1 to C

All hoses to the internal connections are supplied with MLP RO and requires that the RO tank is placed right next to the pumpstation.

3.3 Electrical installation



DANGER!
Danger of electric shock!

Installations and electrical connection must only be done by trained technicians and according to local standards.

High voltages, danger of electric shock! Touching live parts may cause severe injury or death.

All Connections must be made according to the electrical documentation which is found inside the control unit of the electrical cabinet / main box.

Notes on electrical installation

- Installation must be carried out according to local rules and regulations.
- The electrical installation (power supply, humidity control) must be carried out according to the wiring diagram supplied with the unit and the applicable local regulations. All information given in the wiring diagrams must be followed and observed.
- All cables must be run into the control unit via the cable openings and the use of cable glands.
- Make sure the cables do not rub against vibrating parts.
- The supply voltage must comply with the voltage in the wiring diagram.
- Study the system set-up part to get an overview.
- The pump station comes with a 3 m rubber coated power cable.
- Power consumption and size of pre-fuse can be found chapter with product data.

4 Commissioning



The system start-up must be carried out or monitored by persons approved and trained by Condair. Errors in the start-up phase may ultimately result in illness, injury and death of humans.



When fitting water filters, RO membranes, hoses and other components in direct contact with water please, wear sterile gloves or touch only the packing paper to keep the filter bacteria-free.

Remember to wash your hands!

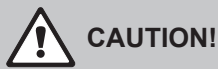

Commissioning of the pump should be the last thing performed at an installation site. When the pump has run with water and the preservation fluid (windscreen wash) has been flushed out, it should always be kept on (summer and winter) in order to keep the system hygienically clean by allowing it to run its automatic flushing and UV routine.

Tools and materials for commissioning work

- Screwdriver set (remember small screwdriver for terminals)
- Polygrip pliers
- Spanner set
- Bucket with litre measure
- Residual hardness test kit, quick method onsite test ML-part: 150400000
- Total hardness test kit, quick method onsite test ML-part: 150401000
- Chlorine-sensitive test strips, quick method onsite test ML-part: 155407200
- Conductivity meter
- BQ water analyses set ML part: 155600010
- Multi-meter (Volt, Amp)

Disconnect the power before starting any commissioning work. Turn the main power switch and the start button to the off position.

4.1 Inlet filter

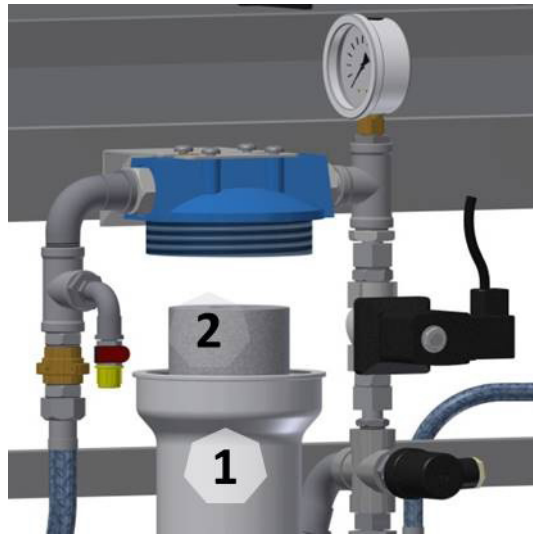

Fig. 18: Inlet filter housing and filter

Insert filter

- Unscrew the filter housing [1] using a filter wrench.
- Insert the filter [2], and make sure that it is centered on the guide knob at the bottom of the filter housing.
- Tighten the filter as much as possible by hand and then use the filter wrench to tighten approx. 1/4 turn.
- Slowly open the water supply
- If the filter housing is hard to tighten or leaks, unscrew it and check that the filter is centered, the O-ring is undamaged and the sealing surface is smooth and free of dirt.

Note: Do not touch the filter with your bare hands (slide it out of the packing directly into the filter housing).

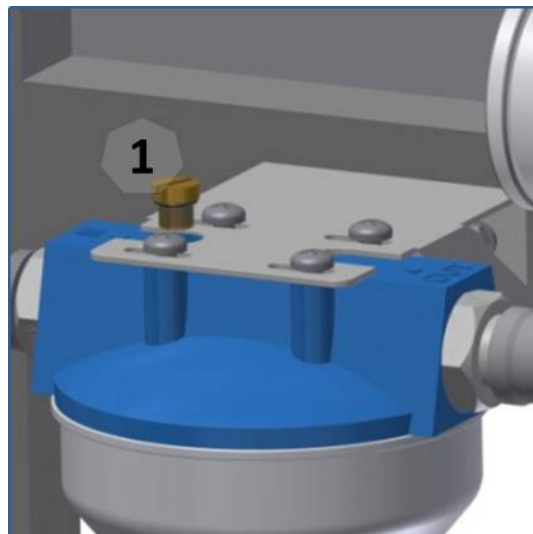



Fig. 19: Air-vent screw, inlet filter

Airing filter:

- Slowly open the water supply (tap) to the MLP RO
- Bleed the filter by loosening the air-vent screw [1] on the filter top until water leaks continuously.
- Retighten the air screw

4.2 Insert RO membrane



The diagram shows a cross-section of an RO membrane assembly. It features a central membrane tube (4) with an end cap (3) at the top. An inlet tube (2) is connected to the side of the tube, and an outlet tube (1) is connected to the top. Hose clamps (5) are used to secure the connections. The membrane (6) is shown being inserted into the tube. The entire assembly is mounted on a cylindrical base.

1: Outlet tube
2: Inlet tube
3: Membrane tube, end cap
4: Membrane tube
5: hose clamps
6: membrane

Start by loosening the hose clamp [5] and then remove the end bottom [3] of the membrane tube. Let the membrane [6] slide into the membrane tube [4]. Make sure that the O-ring on the membrane is facing up (protect the membrane against bacteria, hold on the membrane packaging bag). Press the membrane all the way to the bottom. If there is no resistance at the end, or if the membrane is very difficult to press down, the reason may be that the inner O-rings in the membrane tube end plate are out of place or have fallen out. Check that both the outer and inner O-rings at the end plate (top and bottom) are in place and undamaged. Now press the end plate in place and reinstall the hose clamp.

Note: Do not use grease or the like to lubricate the O-rings. Moisture with water instead.

Fig. 20: Membrane detail

4.3 RO tank breathing filter

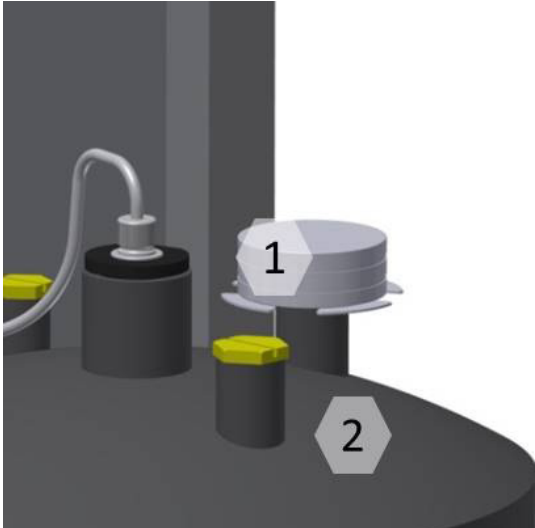

The diagram shows a RO tank (2) with a breathing filter (1) being installed. The filter is a white cylindrical component with a yellow protective cap. The filter is being inserted into a filter adapter (shaped like a small cup) which is mounted on the tank. The adapter has a yellow cap on top. The filter is being pushed into the adapter.

1: Sterile breathing filter [1]
2: RO tank [2]

Remove the yellow protective cap from the RO tank filter adapter (shaped like a small cup).
Unpack the filter [1] and moisten the O-ring with running water.
Avoid touching the nipple and the O-ring with your bare hands.
Press the sterile breathing filter into the filter adapter.

Fig. 21: RO tank breathing filter

4.4 Prepare for pump flush



CAUTION!

The first time a new pump and/or RO membrane is to be used, it is important to flush out any preservation fluids so that they do not end up in the high-pressure system.

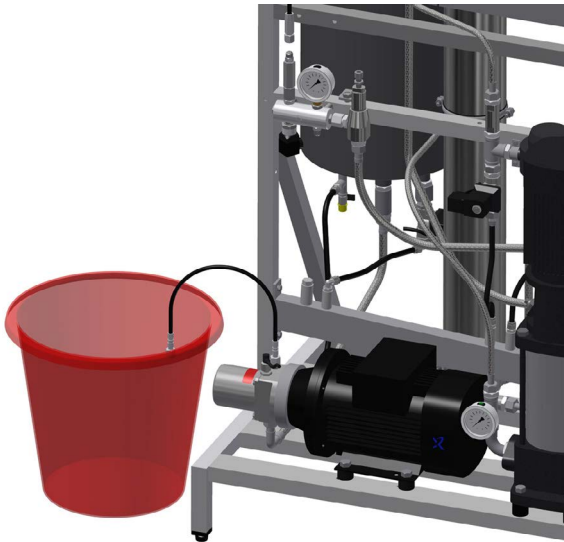

- Remove plugs and strips from the highpressure hose and lead it to a drain or a bucket.

Fig. 22: Flushing the pump

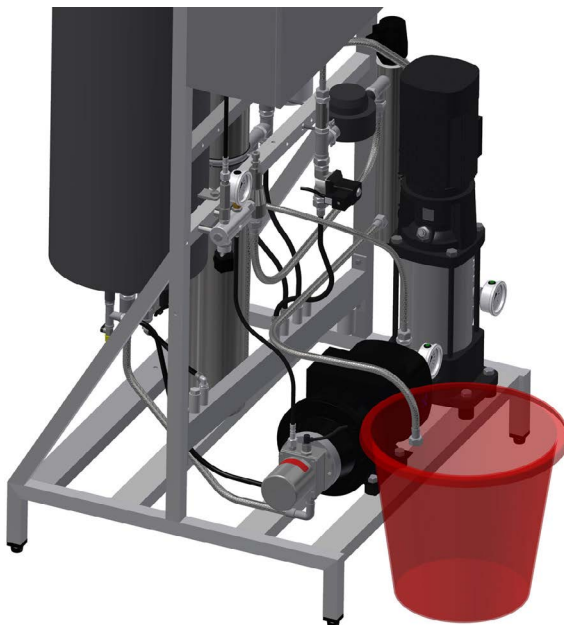

- Remove the filling hose for the RO tank (RO hose) and lead it to a drain..

Fig. 23: Flushing the RO tank

Before the pump is started for the first time, the controller must be set up

4.5 Basic set-up of the controller



Fig. 24: Control cabinet

- 1: Display (D2)
- 2: ON/OFF (S1)
- 3: Reset/Start (S1/P1)
- 4: Keyhole
- 5: Main power switch (S3)

- Put S1 in OFF position
- Start the controller by turning the power switch S3 in ON position
- The display lights up the start center → ► START

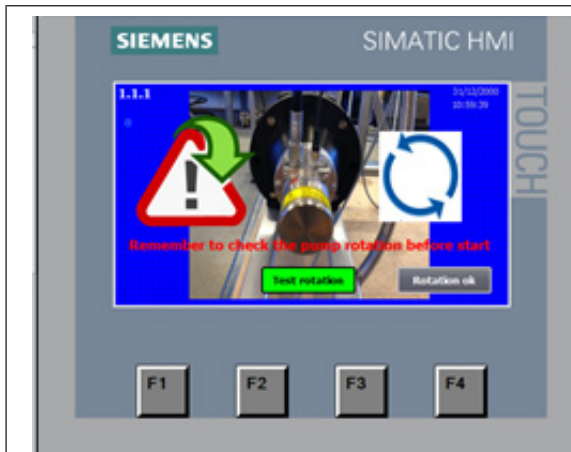

1.1.1

Every time the system is switched on after a power break, you will see a screen that tells you to control the pump rotation.

Verify that the pump rotation is correct.

A push on the Test rotation starts the high-pressure pump for 5 seconds, so that the rotation can be observed according to the arrows on the pump.

When the rotation control has passed it is possible (by customer's responsibility) to skip this screen in the future (It can be deselected in screen 1.6).

Upon completion of rotation control, press Rotation ok.

A technician pin will be required; 197



1.1

Select language by pressing the flag.

Select the units to use in the screens.

- Litre/hour
- Lb/hour
- Celsius
- Fahrenheit

Press the right arrow (F4) to continue.

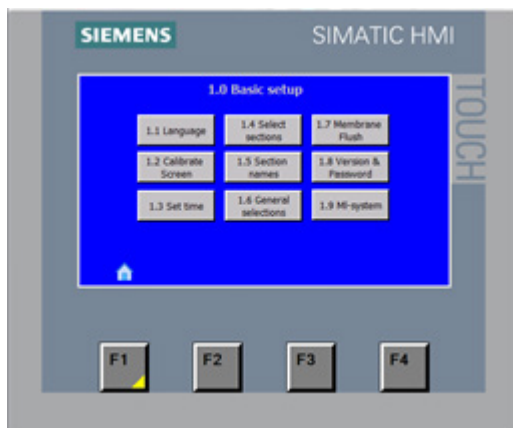

1.0

The Basic setup page provides access to pages and selectable functions:

- 1.1 - Choice of language
- 1.2 - Calibration of screen
- 1.3 - Set time and date
- 1.4 - Selection of active sections
- 1.5 - Selection of names for the sections
- 1.6 - General selections (settings)
- 1.7 - Membrane flush
- 1.8 - Version and change passwords (factory settings)
- 1.9 - ML-System (factory settings)

Once you have made your selection(s), press Home (F1) to continue.

1.2

Calibrate Screen: Adjusts the viewing angle, so you can stand upright and operate the screen. When calibrating, do not lean forward in order to get a better view. You will not get the desired effect.



1.3

Time/date can be set (stored in the screen only).
 Note: Remember to press F3 to set the PLC clock



1.4

Select which section (zones) is active.
 A section is defined as a humidity sensor and a valve set connected to the controller

- Section disabled
- Section enabled

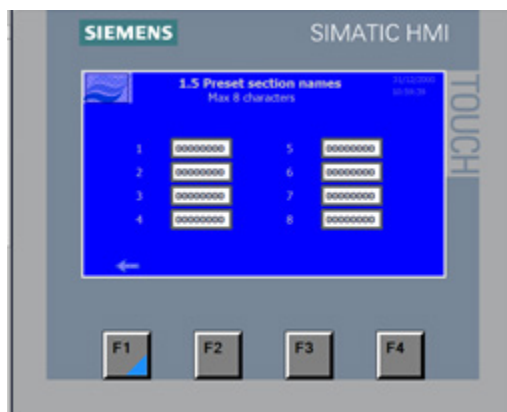

1.5

Selection of user-defined section names.
 You can use up to 8 characters to define each section.

Default is 1-2-3...11-12



1.6

General selection between options and setups for the general pump station. Please note that some of the options require hardware that has to be ordered together with the pump.

Master pin will be required; 8599

Standard setting is the top choice in the drop-down menus.

Here also shown in bold:

- No CIP function
- CIP function

- No fan control
- Aut fan control
- Constant fan control

- No EC monitoring
- EC monitoring
- EC monitoring +RV/CO2
- EC monitoring +MB+CO2

- No pressostat 3
- Pressostat 3

- Aut reset disabled (inlet water low pressure)
- Aut reset enabled (inlet water low pressure)

- 1 section – valve set
- 1 section – no valve set

- Humidity controlled (20-80% RH)
- Direct controlled (0-10 V)
- % controlled (0-100%)

- No Logging
- Logging selected

- Rotation check enabled (1.1.1)
- Rotation check disabled (1.1.1)

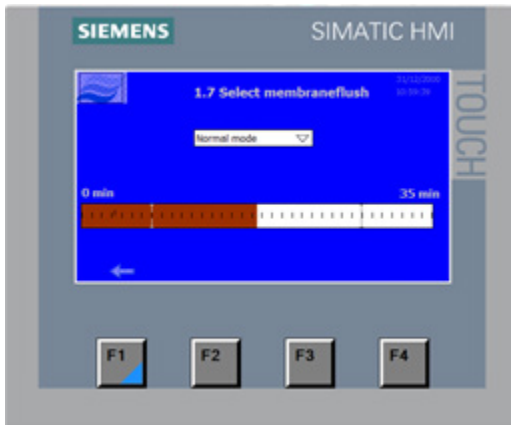

1.7

Select whether membrane flush has to be used.

- Normal mode
- Membrane flush (remember to put back in normal mode after flushing)



1.8

Select MLP size and select 1-4 or 1-8 sections. This selection is pre-set from factory according to the controller hardware.

Changing password is only possible with the master password.

1.9

Factory service screen and settings

RO flush timer 1 (default 20 sec)

RO flush timer 2 (default 30 sec)

- RO pump enabled
- RO pump disabled

Auto reset inlet pressure error:

Delay before attempt to reset (default 30 minutes)

Maximum number of resets tried (default 2 times)

Transfer (boots PLC)

Maintenance screen (manual operation of pump station)

4.6 Pump flush procedure

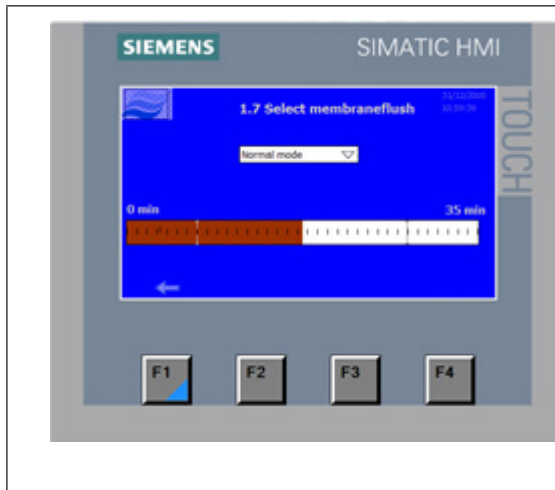

1.7

Select whether membrane flush has to be used.

- Normal mode
- Membrane flush (remember to put back in normal mode after flushing)

Select Membrane flush, RO pump will now start and the flush program will run for 35 minutes.

Monitor the pump during flushing.

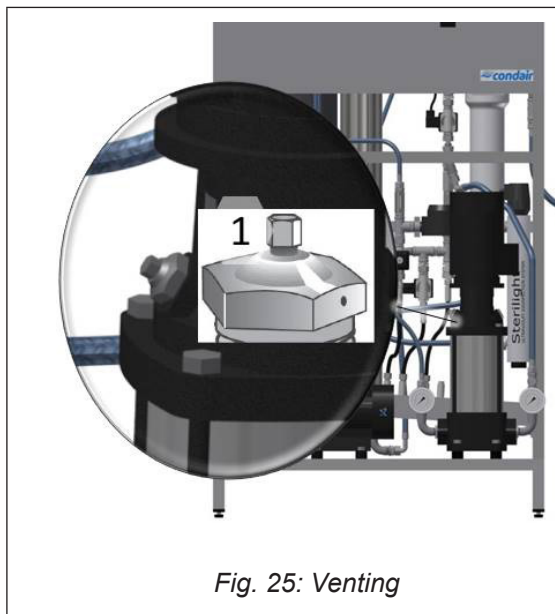

Fig. 25: Venting

If the RO pump does not build pressure or is noisy, it must be vented.

Open the small centre bleeding screw on the RO pump to fill the pump with water and vent any air. Close the valve again. After a few seconds, the air should be out of the system. If not, please repeat the procedure.

After RO flush, refit the RO hose to the RO tank and set RO back to normal operation. The RO should now begin to produce RO water to the tank.

Venting and flushing the high-pressure pump:

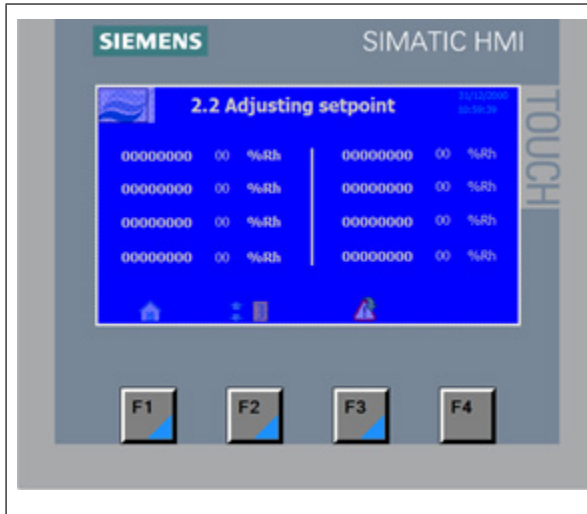

As soon the water in the RO tank reaches the minimum start level the high-pressure pump will now start if a section calls for humidity and the S1 (on/off switch) is turned to the on position.

Force the HP pump to run by adjusting the set point in a section to 75%.

Let the HP pump flush for 10 minutes.



Turn S1 (on/off switch) to off position, and connect the HP discharge hose to the high-pressure manifold.

Note: It is important to use two wrenches, otherwise there is a danger of the glue breaks and high-pressure manifold leaks.

Fig. 26: Connecting HP discharge hose

Leave the main switch turned on and the S1 (on/off switch) in off position. This way the system will perform a flush routine that together with the UV lamp will help keeping the system clean.

4.7 Adjusting the reverse osmosis

Explanation of technical terminology

Permeate:

Processed, desalinated water which is produced by the MLR RO system and supplied to the reservoir tank.

Concentrate:

The water led to the outlet. This water contains salts and minerals that have been removed from the water.

Feed water:

The water which is led directly to the MLP RO.

TDS:

The amount of dissolved salts, measured in mg/l.

Conductivity:

The designation of the water's salt concentration measured in ($\mu\text{S}/\text{cm}$). The lower the value, the higher the water quality.

Membranes:

Is the system filter which desalinates the feed water using high pressure.

RO:

The abbreviation for reverse osmosis.

Transport pump (only on MLP RO 800):

The pump which transports the processed water from the system reservoir's high-pressure pump.

Level switch:

A switch/sensor which emits a signal when the RO system must either be started or stopped, and it stops the transport pump in case of dry running of the reservoir tank.

Softening:

A pre-filter which softens the water, i.e. it removes hardness from the water

4.7.1 Water quality

The feed water, which is to be treated in the MLP RO system, must be of drinking water quality. Please read requirements for inlet water in chapter 1 and under product data at the end of this manual.

If there are doubts about the raw water composition, a water analysis must be made. The MLP RO must be connected to a water pressure of minimum 2.5 bar and maximum 7 bar. The quality of the treated water will be less than 20 $\mu\text{S}/\text{cm}$ at 10°C.

The MLP RO will be adjusted from the factory to the following parameters

MLP RO 100 & 300	20 °dH / 10°C	Permeate/concentrate ratio: Approx. 50/50
MLP RO 500 & 800	1 °dH / 10°C	Permeate/concentrate ratio: Approx. 75/25

Water quality (contact Condair for technical advice)		
Content	Symptom	Preventive action
TOC, BOC and COD	Can cause slimy as well as firm hard film.	Can in some cases be micro-filtrated or removed by means of a carbon filter.
Iron, Manganese (ocher)	Precipitation of iron gives a reddish-brown film and precipitation of manganese gives a black deposit.	Sand filter – oxidation, softening, greensand.
Calcium, magnesium (hard water)	The membrane scales.	Softening, antiscalant
Silica	The membrane scales.	Antiscalant.
SDI (silt)	The membranes gets clogged.	Microfiltration (absolute), ultra-filtration, flocculation.
Oil	The membrane is greasy from oil.	Carbon filter.
Particles	The membrane gets clogged due to hard deposits.	Microfiltration.
Chlorine, pesticides, organic solvents	Membrane deformed. Permeate capacity and quality changed and cannot be CIP-cleaned back to the original capacity. The deformation is not visible.	Free chlorine shall be removed by active carbon filter and chemical cleaning, either with thiosulphate or sulphite.
Bacteria	Membrane is clogged by slime.	Chlorination + de-chlorination, UV, micro-filtration 0.2 $\mu\text{S}/\text{cm}$ and ultra- filtration.

4.7.2 Adjustment of outlet amount

Important! Read the entire chapter before adjustment is started.

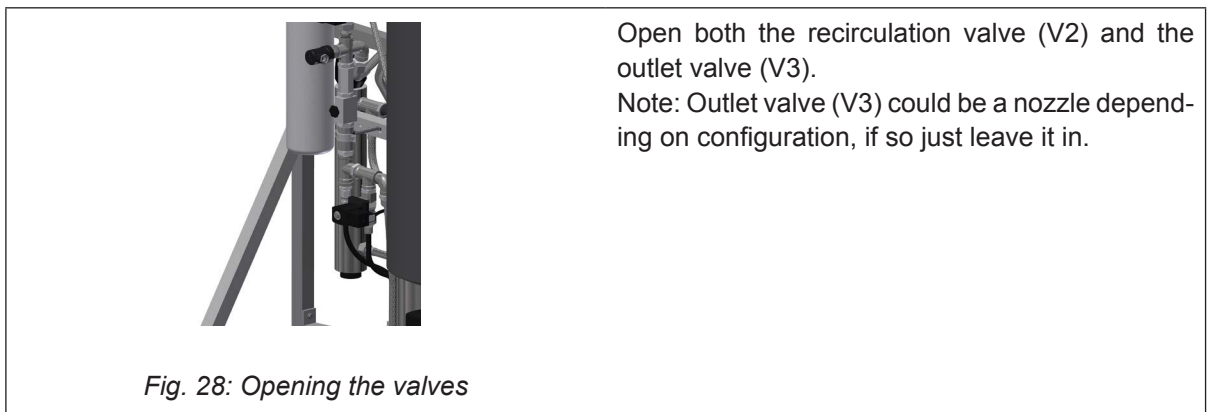

The outlet (concentrate) amount must be adjusted. Which amount is suitable on your system depends on the feed-water quality. Too high water recovery will damage the system membranes. On condition that the raw water complies with the water quality requirements, it can operate at a recovery rate of 70-80% with softening depending on the amount of organic material in the water

MLP RO type	Max Permeate capacity (l/h) *	Outlet amount (l/h) (with softened water)		Outlet amount (l/h) (with tap water)	
		Surface water (75% recovery)	Groundwater (80% recovery)	Surface water (50% recovery)	Groundwater (55% recovery)
100	100	33	25	100	82
300	275	92	69	275	225
500	500	167	125	-**	-**
800	750	250	188	-**	-**

* For every degree the inlet water is below 10°C, the permeate capacity (l/h) must be adjusted down with 3%.

** We recommend always using softening for MLP RO 500 and 800, as the water consumption and wear on membranes will be relatively high. However, local water conditions may in some cases justify running without. Please ask Condair for advice.

Ex.: MLP RO 500 with 80% recovery

$$\text{Outlet amount l/h} = \frac{100 \times \text{Permeate capacity l/h}}{\text{Recovery\%}} - \text{Permeate capacity l/h}$$

$$\text{Outlet amount} = \frac{100 \times 500}{80} - 500 = 167 \text{ l/h}$$

Start the RO system and adjust the outlet so the desired amount of outlet water has been obtained.

4.7.3 Adjustment of permeate amount

Adjust the permeate amount of the recirculation valve. Adjust the amount of permeate produced to Max Permeate capacity (l/h) of the specific system remember to temperature withdraw 3% from Max Permeate capacity (l/h) For every degree the inlet water is below 10°C

E.g. if the feed water temperature is 8°C, for an MLP RO 300 it means that the permeate capacity will be 6% below the normal 275 l/h, i.e. 258 l/h.

When the requested pressure and permeate capacities have been obtained, check again if the outlet amount has been adjusted correctly.

Note: The system must be started and stopped two times, and then the flow must be re-checked. The valves can then be readjusted if necessary.

Check on the RO pump outlet manometer that it shows the correct operating pressure, 6-10 bar.

Please note that the operating pressure may vary by different temperatures and capacities.

Now check the quality of the processed water on the permeate hose; the conductivity must be below 20 µS/cm (conductivity meter is available as optional equipment).

Check that the outlet water is below 1000 µS/cm

Check that the MLP RO automatically starts and produces treated water.

Check if the MLP RO automatically shuts down by too low feed water pressure or lacking feed water supply. This is done by slowly closing the feed water supply while the MLP RO is in operation. When the water supply has been interrupted, the MLP RO must stop automatically within 10 sec. In order to put the MLP RO back into operation, the water supply must be re-established and the reset button pushed once. The MLP RO will automatically revert back to normal operation! The system is now commissioned and ready for use.

5 Operation

Persons operating the MLP RO's controller must have read and understood this manual.

Knowing and understanding the contents of the manuals is a basic requirement for protecting the personnel against any kind of danger, to prevent faulty operation and to operate the unit safely and correctly.

All safety notes in the installation and operation manual for the MLP RO must be observed and adhered to.

All work described in this controller manual may only be carried out by properly trained personnel which is authorised by the customer.

If you have questions after reading this documentation, please contact your Condair representative who will be happy to assist you.

5.1 Overview control unit

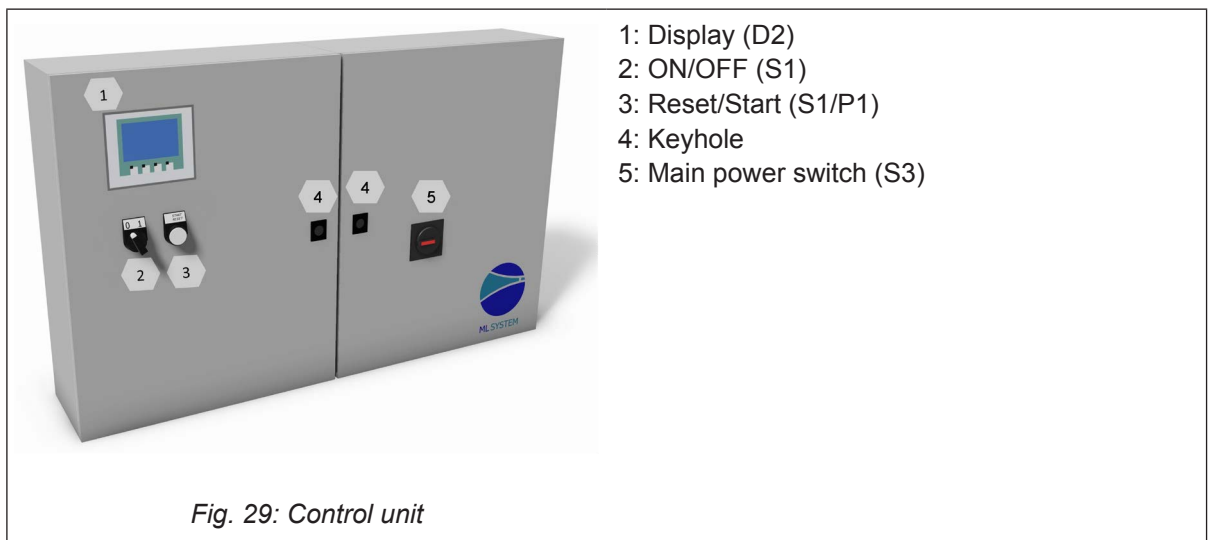

5.2 Equipment protection

Pressure switch (inlet water)

The MLP RO has a pressure switch which monitors the inlet water pressure. If the inlet water pressure drops, the controller will stop the pump, thus protecting it against dry running. If the water pressure drops, the screen will display 'PM Water pressure too low'.

Max. hygostat to protect against excessive humidification

A max. hygostat can be connected to the control cabinet. If humidity levels rise to a value that exceeds the value set on the max. hygostat, the system stops and the alarm lamp flashes. The system will not restart until the alarm is acknowledged by pressing 'Alarm reset'.

Temperature switch

The high-pressure pump is protected against overheating by a temperature circuit that measures the current temperature in the pump. The temperature limits can be set individually.

Default settings:

1. If the temperature exceeds 30°C, the control unit will initially attempt cooling by starting the water treatment part and filling up the tank with cold water. If this makes the temperature drop to below 30°C, the function will reset and everything will continue unchanged. While the tank is being filled, the high-pressure pump will continue unaffected.
2. If instead the temperature continues to rise to above 40°C, the pump will stop and start emptying the tank of overheated water and produce new water in the tank. During this process and until the start level has been reached, the pump will remain idle with the alarm text displayed. The pump will start automatically once the start level has been reached.
3. If the temperature exceeds 50°C, the pump will stop immediately and must be reactivated via the reset button once the temperature has dropped again.

Description of touch screen

The screen has four F keys. Each of the keys is used to navigate between the different screen images. When these are used, the individual key function is indicated in the description directly above the key. The actual touch screen can be operated by gently tapping the relevant screen 'buttons' with your finger. If you want to change a numerical value, press the relevant number key. This will make a numerical keyboard appear on which the new value can be entered. Remember to enter any comma that may be needed.

Any incorrect entry can be deleted using the Backspace button. Once a new value has been entered, press Enter at the bottom right of the image using the numerical keyboard.

Protection against unwanted changes

On the display, the control unit settings are password-protected against unwanted changes. The different user groups have different passwords and different rights.

User (no password) can read operational information and alarms.

User 1 (password 1234) as above + changes of set points.

Technician (password 197) as above + changes of operational parameters and choice of membrane rinse.

Master (password 8599) as above + selectable options, reset to factory settings.

Technician xxxx, as above + factory / service menu.

Additionally, there are areas of the screen that are protected by extra passwords, to which only the ML-System has access.

When a password is required in order to change parameters, a screen will appear where the password can be entered. Parameters can be changed using the numerical keyboard (keys 0-9).

Once the password has been entered, the system is unlocked at the relevant level for five minutes.

5.3 Alarm messages

This page shows alarms and operational messages. The alarm display contains information about when an alarm was triggered and when it was reset. The page shows active alarms and previous alarms. Please note that the system does not have a backup memory, which means that previous alarms will be lost in case of power failure.

Max.Hygrostat Sect. 1

Max. hygrostat in the current section has dropped out due to excessive humidity. The system has stopped and must be restarted once the humidity level has dropped.

Water pressure too low

The water pressure on the water inlet to the pump station is too low.

Sensor error Section 1

The signal from one of the humidity sensors is outside the expected interval of 20 to 80% RH. In order to ensure that it will be possible to start up the system in very dry conditions, the 20% limit is reduced to 5% RH for the first 10 minutes after the system is switched on. If an alarm is triggered, only the affected sections will be stopped.

Emptying Tank – water too hot

The water is too hot – above 40°C. The tank will be emptied to start level and filled with cold water. The pump will run unchanged in the meantime.

Pump too hot

The water is too hot – above 50°C. The system has stopped and must be restarted once the temperature has dropped.

Tank overfull

The water level in the tank is too high – lower the water level and reset the system.
Check that the inlet valve closes tightly when the system is idle.

Thermal relay error

The protective motor switch for the high-pressure pump is disengaged. Engage the relay and try restarting.

UV lamp error

There is an error on the UV lamp

CIP dosing time alarm (option)

The CIP weight has not given a signal within the expected time

CIP weight error (option)

The CIP weight gives an incorrect signal

CIP overdosing last day (option)

The CIP self-monitoring system is defect due to possible overdosing. Please call for service

Operational message display**Water level below start level**

The water level in the container is too low for the pump to start. Once an adequate level has been reached, the system will start automatically.

The pump will start automatically after delay.

The pump has been paused, e.g. after disinfection. The pump will start automatically after the expiry of the set time.

Service

The pre-set service interval has been reached. The system must be serviced!

UV lamp error

The UV bulb or ballast is broken.

UV lamp soon to be changed

Warning 3 weeks prior to UV lamp change / service.

UV lamp error too old

Replace UV lamp and reset service interval.

5.4 Controller menu



2.0

Normal operation page

Shows up to four sections at a time. The names of the section changes colour according to the current status.

- White – normal inactive
- Green – active section – humidification is on
- Yellow flash – humidity out of range
- Red flashing – alarm on the section

Humidity, set point and load for each section.

Just tap the set point to go to the set point adjust screen.

If an alarm or message is triggered, a bar will appear across the screen, showing the message.

From this page, you can access to the menu page, the alarm page, settings as well as other displays.



2.2

Changes of set points for the individual section.



2.3

Shows the pump temperature and the actual flow – calculated after the setting for each section.

If the EC option is selected, lines for the actual EC monitoring will also be displayed.

Hour counter – select between pumps and each section.

Access to the Trend curve for each section.

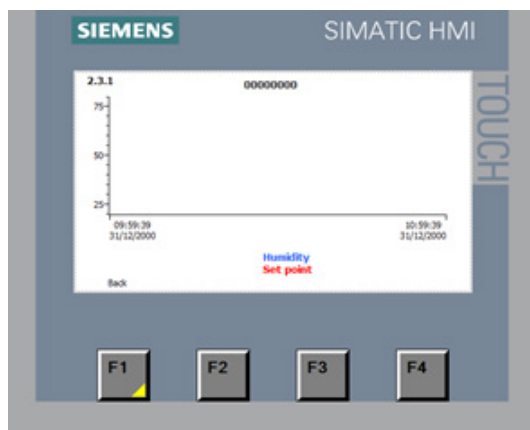

2.3.1

Graphic display of humidity development in the relevant section for the last hour.

Please note that this function will be reset when the power to the screen is cut.

5.4.1 Alarms and user messages

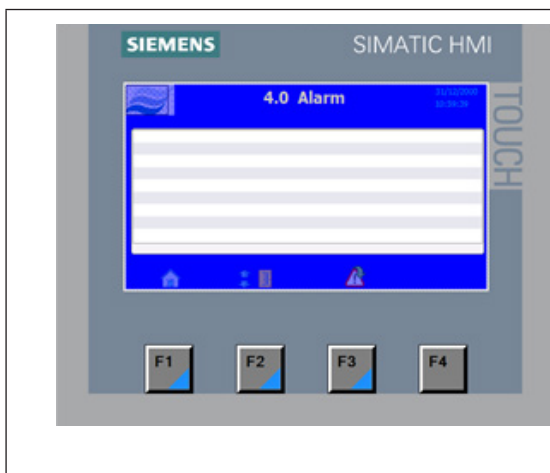

4.0

All alarms and operational messages are shown, showing the time at which they occurred and the time when the alarm stopped.

Please note that the alarm log will be reset after a power cut.

5.4.2 Parameter change menu

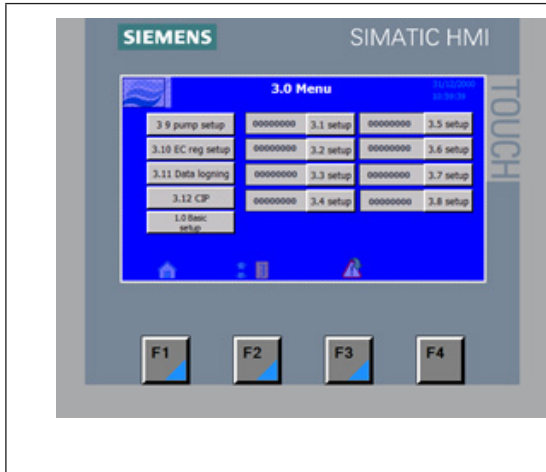

3.0

Menu for the pages where the different parameters can be changed.

5.4.3 Settings for section parameters

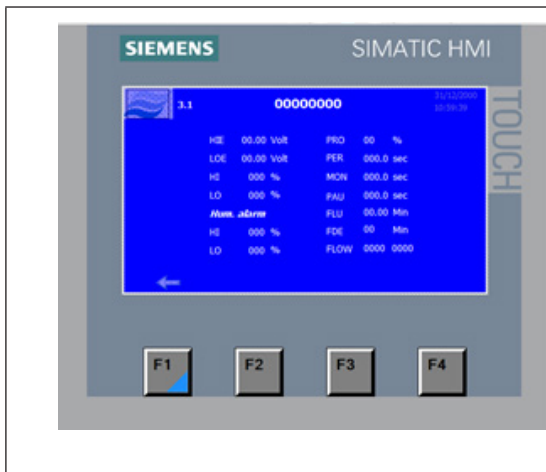

3.1

Section parameters for sensor scaling and regulator settings

These values should be changed by Condair's technicians only.

Hum.Alarm

Set the HI and LO. The alarm appears if the humidity becomes lower than the pre-set value in HI or lower than the pre-set value in LO.

5.4.4 Pump

SIEMENS SIMATIC HMI TOUCH

3.9 Pump setup

Pressostat del 005.0 sec Start after deactivation
Max.SP 96 %/h Delay 00

Pump Temperature

Actual Temp 000.0000

Temp.lim1 28 °C - 82 °F
Temp.lim2 28 °C - 82 °F
Temp.lim3

UV monitoring

UV set 0000 / 0000
UV lamp 000 days left



UV reset

F1 F2 F3 F4

3.9
Pump alarm settings

These values should be changed by Condair's technicians only.

5.4.5 Conductivity monitoring, humidity logging and CIP (options)

	<p>3.10 EC controller set point</p> <p>These values should be changed by Condair's technicians only.</p>
	<p>3.10.1 Scaling EC sensors</p> <p>These values should be changed by Condair's technicians only.</p>
	<p>3.11</p> <p>For detailed description in the logging option, read Condair document TI086.</p>

	<p>3.11.1 Build a log file</p>
	<p>3.12 Select the days you want to run a CIP function – CIP on days (one or two days each week) Select the CIP start time. Select the dosing amount (can only be selected in intervals of 5 ml per 50 litres of water)</p>

5.5 Weekly inspection

During operation, the MLP RO and the humidification system have to be inspected weekly. On this occasion, check the following:

- Entire humidification system for leakage
- Electric installation for damage
- Operating display for warning or error messages
- UV filters
- Pressure drop over filters
- Water treatment systems such as carbon filter, softener, RO

If the inspection reveals any irregularities (e.g. leakage, error indication) or any damaged components take the MLP RO out of operation. Have a qualified specialist or Condair service technician correct the damage or malfunction.

Fill in the 'Service form for weekly monitoring of humidifying systems' provided in the Appendix of this manual. Failing to do so could affect your warranty.

6 Maintenance

6.1 Important notes on maintenance

Qualification of personnel

All maintenance work must only be carried out by qualified and trained personnel authorised by the owner. Maintenance and repair of the electrical installation of the Condair MLP RO must only be carried out by qualified personnel (e.g. electrician) who are aware of possible dangers and implications. It is the owner's responsibility to verify proper qualifications of the personnel.

General note

The instructions and details for maintenance work must be followed. Only maintenance work described in this documentation may be carried out. Use only original ML-System spare parts to uphold the system warranty.

Safety

Before maintenance is initiated, the MLP RO must be taken out of operation in accordance with instructions in the section 'Taking the MLP RO out of operation'. Protect the system against unintentional switch-on. The MLP RO must be cleaned and disinfected at the intervals described in this manual and cleaning must be performed by trained and instructed personal.



WARNING!

Poorly maintained humidification systems may endanger health. Therefore it is mandatory to observe the specified maintenance intervals and to carry out maintenance in strict accordance with the instructions.

6.2 Maintenance work

To ensure safe, hygienic and economic operation of the MLP RO, vital components must be checked and maintained periodically according to the table below. The maintenance intervals and maintenance work stated below are guideline values. Local conditions, quality of the water, etc. could influence the maintenance intervals. After having carried out the maintenance work, fill in the maintenance checklist, sign it and reset any maintenance indications. The relevant personnel are responsible for any maintenance work not carried out.

Service, to be carried out	Half year	Each year	Every 2 years	Every 4 years
Review of the system				
Testing of the system's overall function	X	X	X	X
Meter reading of water consumption (if present)	X	X	X	X
Reading of pump running hours	X	X	X	X
Logbook registration	X	X	X	X
Control weekly monitoring checklist	X	X	X	X
Water treatment system / incoming water				
Analysis of water hardness (in case of water softening)	X	X	X	X
Pump unit				
Replacement of filters	X	X	X	X
Check the condition of the pump (pressure & noise)	X	X	X	X
Testing of solenoid valves and replacement if necessary	X	X	X	X
Change gasket kit in high pressure reducing valve		X	X	X
Functional testing of max hygostat circuit	X	X	X	X
Functional testing of high pressure gauge	X	X	X	X
Functional testing of pressure switch (pressostat)	X	X	X	X
Service inspection of PAHT pump (age 2 years or 8000 running hours)			X	X
Testing of ON/OFF valve and replacement if necessary	X	X	X	X
Reverse osmosis systems/RO				
Measurement of conductivity	X	X	X	X
Testing of overall function and settings for the RO system	X	X	X	X
Leak testing	X	X	X	X
Performance test (produced water, drain water)	X	X	X	X
Testing of valves	X	X	X	X
Replacement of sterile breather filter		X	X	X
Testing of membrane and replacement if necessary	X	X	X	X
Disinfection / cleaning of tank	X	X	X	X
UV system				
Functional testing of UV systems	X	X	X	X
Cleaning of quartz glass on UV systems	X	X	X	
Replacement of UV-lamp		X	X	X
Replacement of quartz glass				X
Humidity sensors				
Testing and adjusting of humidity sensors. Replaced if +/- 10% deviation	X	X	X	X
Checking of max humidity controller (max hygostat)	X	X	X	X

Service, to be carried out	Half year	Each year	Every 2 years	Every 4 years
Control units				
Analysis and testing of programming	X	X	X	X
Transfer relay replacement		X	X	X
Testing of contact K1 and replacement if necessary		X	X	X
Hygiene				
Extraction of water sample from pump (Bacterie test)	X	X	X	X
Desinfection of the system	X	X	X	X

6.3 Preventive spare parts chart

MLPRO recommended preventive/critical spare parts list, 4 year maintenance cycle													
Pump serial number from 2014001 to 2015999													
ML-System		MLPRO 100	MLPRO 300	MLPRO 500	MLPRO 800	6 month	First year	6 month	second year	6 month	Third year	6 month	Fourth year
		Designation	Part number	Pcs needed									
Water filter (F1)													
Filter 5 micron 20"	104551000	1	1	1	1	X	X	X	X	X	X	X	X
O-ring for water filter	430020050	1	1	1	1			X					X
Air Filter for RO tank (F2)													
Sterile breather filter 0,2 my	104581000	1	1	1	1		X		X		X		X
UV Filter, 30 mJ/cm2 (UV)													
UV Bulb 212	104594000	1					X		X		X		X
UV Bulb 330	104595000		1	1	2		X		X		X		X
Quartz Sleeves 212	104582001	1											X
Quartz Sleeves 330	104582501		1	1	2								X
RO membrane (RO)													
4" for MLPRO: inlet water quality 250 µS and higher	2612213	1	1	2	3								X
4" for MLPRO: inlet water quality 250 µS and lower	2613395	1	1	1	3								X
Electrical control system													
Print frame relays 230V (1 for each zone)	680010177	4	4	4	4		X		X		X		X
Contactora (Q1) Siemens	349010205	2	2	2	2								X
High pressure pump (P2)													
Service kit for PAHT 2	104466001	1							X				X
Service kit for PAHT 4/6.3	104466002		1	1					X				X
Service kit for PAHT 10	104466003				1				X				X
Service kit coupling PAHT 2/4	240020072	1	1										X
Service kit coupling PAHT 6.3	240020072			1									X
Service kit coupling PAHT 10	240020073				1				X				X
Pressure regulator (R2)													
Service kit	104481000	1	1	1	1		X		X		X		X
On/off valve (MV1)													
On/off valve rep kit	XXXXXXXXX	1	1	1	1								X
Check valve high pressure (K4,K5,K8)													
Check valve 1/4" (K4)	510020000	1	1						X				X
Check valve 3/8" (K5/K8)	510020005			1	1				X				X
Disinfection													
Sanosil S010 Ag (1 liter bottle)	155405000	1	1	1	2	X	X	X	X	X	X	X	X
Sanosil S010 Ag (10 liter bottle)	155404000					X	X	X	X	X	X	X	X

6.5 Troubleshooting

Qualification of personnel

Have faults eliminated by qualified and trained personnel only. Malfunctions caused by the electrical installation must only be repaired by authorised personnel (e.g. electrician).

Repair work on the high-pressure pump may only be carried out by your Condair representative's service technician.

Safety

When eliminating faults, the MLP RO must be taken out of operation and prevented from further inadvertent operation.

Make sure the power supply to the MLP RO is disconnected (test with a voltage tester) and that the stop valve in the water supply line is closed.

6.5.1 Malfunction with error indication

Error message	Cause	Remedy
Max. humidistat	Max. humidistat has been tripped, due to high humidity	Check that ventilation is on Set point is correct Incoming set point signal OK
	Max. humidistat defect or incorrectly set	Change max. humidistat Set correct rel. humidity, e.g. 85% RH
	Max. humidistat circuit damaged or not installed correctly	Check circuit for faults Check settings for max. humidistat in controller are correct If no max. humidistat, a jumper must be installed over terminals (4 & 4+)
Inlet water pressure too low	The inlet water pressure is too low	Check the inlet pressure at maximum flow for pump station according to product data
	The Inlet water pressure is too low for short periods (if inlet pressure and flow seems ok when measured)	Check the water installation for periodically high consumption e.g. cleaning, tank filling and maintenance work
	Defect Inlet pressure switch [PS]	Replace pressure switch
Sensor error	Humidity sensor missing or defect	Install humidity sensor
	Wiring to humidity sensor damaged or incorrectly installed	Replace wiring according to electrical diagram
	Humidity outside range (below 20% RH or above 80% RH)	Check the humidity at sensor and reset if below 20% RH
	Sensor scaling is wrong	Scale the sensor correctly in the controller
Emptying tank - water too hot (only for MLP RO systems)	Ambient temperature too high at pump location (max. 25°C)	Lower ambient temperature in pump room (max. 25°C)

Error message	Cause	Remedy
Stop - Pump too hot	Water flow through high-pressure pump too low	Check flush valve MV5 at step valve block opens and nozzle are not clogged
	Ambient temperature too high at pump location (max. 25°C)	Lower ambient temperature in pump room (max. 25°C)
	Incoming water too warm	Lower inlet water temperature (max. 15°C)
	Inlet pressure / flow missing	Defect inlet valve [MV1] Water supply blocked / closed
	Damaged thermostat or cable [T]	Change thermostat and cable
	High-pressure pump defect	Locate cause of failure, e.g. running hours exceeded 8,000, particles / dirt in system, missing water pressure, defect inlet valve. Change pump when cause of failure has been established and corrected
Tank full	Top float switch on RO tank level stick has been activated	RO pump does not stop, check motor start relay Inlet valve [MV1] leaks, change / overhaul valve
FD error	Frequency converter error	Turn off the main power to pump station, wait 15 seconds then restart the system Check the settings on the Frequency converter according to the electrical diagram Check whether pressure in high-pressure system is too high/low
High-pressure low/high	Outlet high-pressure side outside pre-set value of 40-70 bar	Check high-pressure at pressure gauge Check pre-set value in the controller, if pressure seems ok at pressure gauge Check pressure regulating valve functions correctly and is set to 65 bar Low pressure can be caused by leaks, defect valves, missing nozzles on the high-pressure line. Check high-pressure pump Check pressure sensor functions correctly Check pressure sensor relay functions correctly
Phase sequence relay	Phase sequence are not correct	Change phase sequence
	A phase is missing	Restore missing phase
	There has been a short-term power failure	Reset

6.5.2 Resetting the error indication

Press the reset button underneath the touch screen.

Note: If the fault has not been eliminated, the error indication reappears after a short while.

6.5.3 Malfunction without error indication

The following table provides malfunctions that do not trigger messages about the cause of the malfunction or information on how to eliminate the source of the malfunction.

Malfunction	Cause	Remedy
Water's dripping from modules/flex/nozzles	Defect / clogged nozzles	Replace nozzles
	Zone valves defect / leaking	Repair valves
	Air in system	Air the entire system
	Pressure too low	Check / repair PAHT pump
	Water below 5 yS/cm	Adjust RO pressure
Condair MLP RO humidifies permanently.	Nominal humidity value too high.	Reduce nominal humidity value.
	Ambient humidity very low.	No measures to be taken, just wait.
	The internal controller is activated, although an external controller is connected	Deactivate internal controller.
Maximum humidification capacity not reached.	Air change too high	Contact your Condair supplier.
	Defective zone valves	Check the function of valves
	Hygrostat defect	Check calibration and function
	Spray nozzles clogged.	Remove nozzles and replace them
	Hoses to nozzle pipes are leaking or disconnected, or nozzle pipes are leaking.	Check hoses/nozzle pipes and seal, as required
Control unit is switched on but the display of the control unit does not show anything.	Service switch in power supply line is off.	Set service switch in power supply line to On position.
	Fuses of the power supply line blown	Have an electrician replace fuses of the power supply line.
	Fuse of control unit blown	Have an electrician replace fuse of the control unit.
	Display or control board defective	Have a Condair service technician replace the display or the control board.

7 Product data

	MLP RO 100	MLP RO 300	MLP RO 500	MLP RO 800
Capacity, 50 & 60 Hz (Inlet water temp 15°C)	100 l/h	265 l/h	440 l/h	750 l/h
Water consumption	200 l/h	600 l/h	700 l/h	1100 l/h
Water supply dynamic pressure [bar]	2.5 - 7.0	2.5 - 7.0	2.5 - 7.0	2.5 - 7.0
Softened water recommended	no	no	yes	yes
Water out µS/cm	5 < EC < 30	5 < EC < 30	5 < EC < 30	5 < EC < 30
Permeate/Concentrate ratio	55/45	55/45	75/25	75/25
Saline retention, %	> 95	> 95	> 95	> 95
Dimensions w x d x h [mm]	860x700x1600	860x700x1600	860x700x1600	1400x700x1600
Extern RO-tank, liters	50	50	200	500
Dimensions Extern RO-tank w x d x h [mm]	integrated	integrated	600x600x955	800x800x1250
Weight Pump, kg	125	130	220	250
Sound pressure level, dB(A)	< 75	< 75	< 75	< 75
High pressure outlet	1 x 1/4" HPF	1 x 1/4" HPF	1 x 3/8" HPF	1 x 3/8" HPF
Pipe diameter - inlet, "RG	3/4"	3/4"	3/4"	3/4"
Pipe diameter - Drain "RG	3/4"	3/4"	3/4"	3/4"
IP class	IP54	IP54	IP54	IP54
50 Hz				
Electrical conn. 3-phased	Un = 220-240 V			
Absorbed Power [kW]	0,9	1,1	2,1	3
kW -RO	0.37	0.75	0,75	0,75
Pre fuse	16 A	16 A	20 A	25 A
Electrical conn. 3-phased	Un = 308-415 V			
Absorbed Power [kW]	0,9	1,1	2,1	3
kW -RO	0.37	0.75	0,75	0,75
Pre fuse	16 A	16 A	16 A	16 A
60 Hz				
Electrical conn. 3-phased	Un = 208-277 V			
Absorbed Power [kW]	0,9	1,1	2,1	3
kW -RO	0.37	0.75	0,75	0,75
Pre fuse	16 A	16 A	16 A	20 A
Electrical conn. 3-phased	Un = 400-480 V			
Absorbed Power [kW]	0,9	1,1	2,1	3
kW -RO	0.37	0.75	0,75	0,75
Pre fuse	16 A	16 A	16 A	16 A

8 Declaration of conformity



EC - Declaration of Compliance

Manufacturer:

Condair A/S
Parallelvej 2
8680 Ry

We hereby declare, that the following pump systems for humidification purposes:

ML RO 100; ML RO 300; ML RO 500; ML RO 800; ML RO 1000; ML RO 1500;
HP 100; HP 200 VFD; HP 300; HP 500; HP 500 VFD; HP 800; HP 800 VFD; HP 1300 VFD
HP RO 100; HP RO 200 VFD; HP RO 300; HP RO 500; HP RO 500 VFD; HP RO 800; HP RO 800 VFD
MLP 100; MLP 300; MLP 500; MLP 800; MLP 1000; MLP 2x800; MLP 2x1000; MLP 3x800; MLP 3x1000
MLP RO 100; MLP RO 300; MLP RO 500; MLP RO 800
MLP HRO 100; MLP HRO 300
MLPD 300; MLPD 500; MLPD 1000;
MLPG 100; MLPG 300; MLPG 500; MLPG 800; MLPG 1000;

are manufactured in accordance with the following EC directives:

- 2006/42/EC, Directive on machinery
- 2014/30/EC, EMC (ElectroMagnetic Compatibility) Directive
- 2014/35/EC, The low voltage directive
- 2011/65/EC, ROHS Directive on the restriction of the use of certain hazardous substances in electrical and electronic equipment.

The following harmonized standards have been applied:

- EN ISO 12100:2011, Safety of machinery – General principles for design – Risk assessment and risk reduction
- EN ISO 13849-1:2008, Safety of machinery – Safety-related parts of control systems – Part 1: General principles for design.
- EN 55022:2011+AC, Information technology equipment – Radio disturbance characteristics – Limits and methods of measurement
- EN 60204-1:2006 + amendments, Safety of machinery – Electrical equipment of machines – Part 1: General requirements

The following international standards and technical specifications are used:

- IEC 60034-1 ed. 12.0, Rotating electrical machines - Part 1: Rating and performance
- IEC 60034-5 ed. 4.1, Rotating electrical machines - Part 5: Degrees of protection provided by the integral design of rotating electrical machines (IP code) – Classification
- IEC 60034-6 ed. 2.0, Rotating electrical machines - Part 6: Methods of cooling (IC Code)
- IEC 60034-8 ed. 3.1, Rotating electrical machines - Part 8: Terminal markings and direction of rotation
- IEC 60320 ed. 2.1, Appliance couplers for household and similar general purposes - Part 1: General requirements

DK-Ry, November 26, 2015

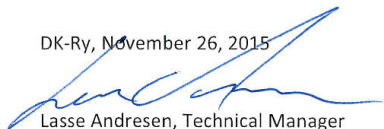

Lasse Andresen, Technical Manager

Condair A/S
Parallelvej 2, DK-8680 Ry
Tel. +45 8788 2100
www.condairsystems.dk

9 Appendices

Modbus TCP/IP Gateway IP translator (option)

Connect the MODBUS TCP/IP, to a sub net for Condair PLC.

Allan Bradley 9300-ENA

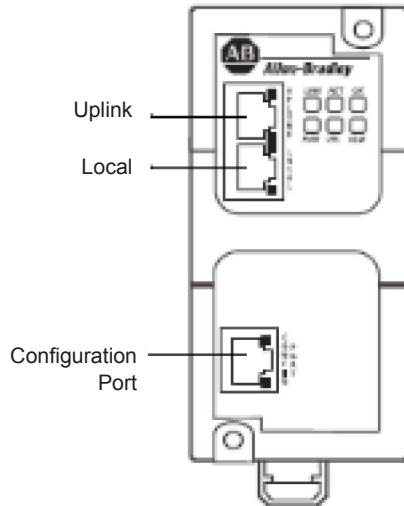
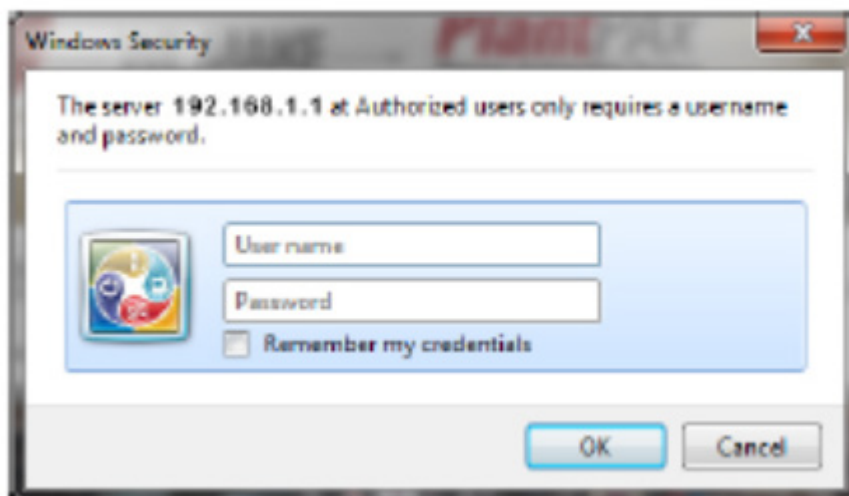

Fig. 30: Allan Bradley 9300-ENA

Change your IP on your PC's **network interface controller** to **192.168.1.3** and the **Subnet mask** to **255.255.255.0**

Connect to the Allan Bradley 9300-ENA Unit according to the following steps:

1. Open a browser window
2. Enter the default IP address of 192.168.1.1 in the address bar, press Enter, and note the following defaults
 - *Username should be left blank
 - *password is PASSWORD



Allen-Bradley 9300-ENA

Expand Minimize

Home

- Basic Configuration
- Network
- Security
- Miscellaneous
- Applications
- 1:1 NAT
- Discovery
- System
- Backup/Restore
- Performance
- Restart/Reset
- Support
- Upgrade Firmware

Network Configuration

Uplink Interface (Public)

IP Address: 10.20.30.1

Subnet Mask: 255.255.255.0

Default Gateway: 0.0.0.0

Allow Configuration: Disabled

Local Interface (Private)

IP Address: 192.168.100.200

Subnet Mask: 255.255.255.0

Allow Configuration: Disabled

Configuration Interface

DHCP Client: Enabled *No response from DHCP server!*

Assigned IP Address: 192.168.1.1 (default)

Assigned Subnet Mask: 255.255.255.0 (default)

Apply Changes Discard

Copyright © 2013 Rockwell Automation, Inc. All Rights Reserved.

UPLINK
LOCAL
CONFIG

Public IP address for the module.
Change the IP to fit to the network for the CTS/BMS system.

Allen-Bradley 9300-ENA

Expand Minimize

Home

- Basic Configuration
- Network
- Security
- Miscellaneous
- Applications
- 1:1 NAT
- Discovery
- System
- Backup/Restore
- Performance
- Restart/Reset
- Support
- Upgrade Firmware

Configuration Basic Example Advanced Example Factory Cells Example

Network Address Translation

1:1 NAT: Enabled

Network Address Translation Rules

Active	Public IP (Range)	Private IP (Range)	Comment	Edit / Del
<input checked="" type="checkbox"/>	10.20.30.5	192.168.100.220	MODBUS to PLC	
	New IP Address	New IP Address Range		

Apply Configuration applied successfully

Copyright © Rockwell Automation, Inc. All Rights Reserved.

Public IP address for the MODBUS connection. Change the IP to fit to the network for CTS/BMS system.

Use this address in the MODBUS connection as server/slave address.

Example net 10.20.30.xx

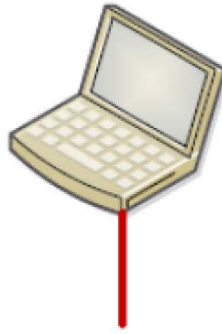

10.20.30.10

GW = None (no L3 switch or router)



10.20.30.1 (Public IP)

GW = None (no L3 switch or router)

1:1 NAT rules	
Public	Private
10.20.30.5	192.168.100.220



192.168.100.200 (Private IP)

IMPORTANT!!!!
The machine's new gateway is the IP address of the ENA private port (192.168.100.200)

Public address of the machine is 10.20.30.5



PLC
192.168.100.220



Touch screen

GW = 192.168.100.200

MLP RO Modbus TCP/IP	Technical data		
	TD139GB-00	25-02-02	LJ

MODBUS communication TCP/IP

ML-System humidification controls with PLC control is available with an option that allows connection to CTS / BMS systems via Modbus TCP / IP.

The physical connection is made with a standard Ethernet cable that connects the PLC controller with a standard RJ45 connector.

The option includes changes in the software, and a list of setup and the addresses of parameters to be transferred between the PLC system and CTS / BMS.

The connection gives actual humidity for each section and general information on the system status. And it is possible to change setpoint from the BMS system. In addition, there is also a current "status" integer that describes the plant's operational status so alarms can be transferred to the BMS.

The Modbus TCP / IP connection is set up with ML-System's PLC as Server/(slave) – and the BMS as a client/(master).

IP PLC: 192.168.135.220 Subnet mask 255.255.255.0
Connect ID 1
Port 502
MB Data addresses 40001 – 40033
Data format Integer (int)

Setpoint 1	R	Integer	40001	%RH
Setpoint 2	R	Integer	40002	%RH
Setpoint 3	R	Integer	40003	%RH
Setpoint 4	R	Integer	40004	%RH
Setpoint 5	R	Integer	40005	%RH
Setpoint 6	R	Integer	40006	%RH
Setpoint 7	R	Integer	40007	%RH
Setpoint 8	R	Integer	40008	%RH
Setpoint 9	R	Integer	40009	%RH
Setpoint 10	R	Integer	40010	%RH
Setpoint 11	R	Integer	40011	%RH
Setpoint 12	R	Integer	40012	%RH
Humidity 1	W	Integer	40013	%RH
Humidity 2	W	Integer	40014	%RH
Humidity 3	W	Integer	40015	%RH

Humidity 4	W	Integer	40016	%RH
Humidity 5	W	Integer	40017	%RH
Humidity 6	W	Integer	40018	%RH
Humidity 7	W	Integer	40019	%RH
Humidity 8	W	Integer	40020	%RH
Humidity 9	W	Integer	40021	%RH
Humidity 10	W	Integer	40022	%RH
Humidity 11	W	Integer	40023	%RH
Humidity 12	W	Integer	40024	%RH
Tank level	W	Integer	40025	%
Actual flow	W	Integer	40026	l/h (lb/h)
EC Ro	W	Integer	40027	µS
EC MB1	W	Integer	40028	µS
EC MB2	W	Integer	40029	µS
EC tank	W	Integer	40030	µS
Status mode	W	Integer	40031	
On/Off	W	Boolean	40032.1	
alarm general	W	Boolean	40032.2	
Level in tank ok	W	Boolean	40032.3	
Water pressure low	W	Boolean	40032.4	
Pump overheated	W	Boolean	40032.5	
Pump2 overheated	W	Boolean	40032.6	
tank overfull	W	Boolean	40032.7	
UV error	W	Boolean	40032.8	
UV age warning	W	Boolean	40032.9	
UV age alarm	W	Boolean	40032.10	
Sensor error	W	Boolean	40032.11	
MaxHyg error	W	Boolean	40032.12	
Cip Alarm	W	Boolean	40032.13	
EC RO alarm	W	Boolean	40032.14	
EC MB1 alarm	W	Boolean	40032.15	
EC MB2 alarm	W	Boolean	40032.16	
EC tank high alarm	W	Boolean	40033.1	
EC tank low alarm	W	Boolean	40033.2	
Too many pump stopped	W	Boolean	40033.3	
Internal setpoint	W	Boolean	40033.4	
Not used	W	Boolean	40033.5	
Not used	W	Boolean	40033.6	

Not used	W	Boolean	40033.7	
Not used	W	Boolean	40033.8	
Not used	W	Boolean	40033.9	
Not used	W	Boolean	40033.10	
Not used	W	Boolean	40033.11	
Not used	W	Boolean	40033.12	
Not used	W	Boolean	40033.13	
Not used	W	Boolean	40033.14	
Not used	W	Boolean	40033.15	
Not used	W	Boolean	40033.16	

Set point	Technical data		
	TD020GB-00	10-12-14	JLJ/KK

The ON-time for the pump, when the humidity is between setpoint and (setpoint - proportional band), can be calculated after the formula:

$$T(\text{on}) = \text{Period time} \times (1 - (\text{humidity level} - \text{Setpoint} + \text{Pro.band})/\text{Pro.band})$$

Example: Period time: 3 min., Setpoint: 80% RH, Pro.band: 30%, Minimum ON-time 0,2 min.

With the values from the example above the ON-time for 78, 70 og 60% RH is calculated:

If the humidity level in the room is 78% RH, the ON-time for the pump is:

$$T(\text{on}) = 3 \times (1 - (78 - 80 + 30)/30) = 3 \times (1 - 0,933) = 0,20 \text{ min.} = 12 \text{ sec.}$$

If the humidity level in the room is 70% RH, the ON-time for the pump is:

$$T(\text{on}) = 3 \times (1 - (70 - 80 + 30)/30) = 3 \times (1 - 0,667) = 1,00 \text{ min.}$$

If the humidity level in the room drops to 60% RH, the ON-time for the pump is:

$$T(\text{on}) = 3 \times (1 - (60 - 80 + 30)/30) = 3 \times (1 - 0,333) = 2,00 \text{ min.}$$

New Proportional band: If the proportional band in the above example is reduced to 20% instead, the ON-time for the pump will change quicker when the humidity drops in the room.

Period time: 3 min., Setpoint: 80% RH, **Pro.band:** 20%, Minimum ON-time 0,2 min.

If the humidity level in the room is 78% RH, the ON-time for the pump is:

$$T(\text{on}) = 3 \times (1 - (78 - 80 + 20)/20) = 3 \times (1 - 0,90) = 0,30 \text{ min.} = 18 \text{ sec.}$$

If the humidity level in the room is 70% RH, the ON-time for the pump is:

$$T(\text{on}) = 3 \times (1 - (70 - 80 + 20)/20) = 3 \times (1 - 0,50) = 1,50 \text{ min.}$$

If the humidity level in the room drops to 60% RH, the ON-time for the pump is:

$$T(\text{on}) = 3 \times (1 - (60 - 80 + 20)/20) = 3 \times (1 - 0,0) = 3,00 \text{ min. (100%).}$$

If the humidity level in the room drops below 60% RH, (setpoint - pro. band) the pump will run all the time - Minimum OFF-time (PAU).

Note that the running time of the pump changes quicker when the proportional band is lower.

New Period time: If the period time is changed, the ON- and OFF-times will change accordingly.

Example: Period time in the example changes from 3 to 5 min.

Period time: 5 min., Setpoint: 80% RH, Pro. band: 20%, Minimum ON-time 0,2 min.

If the humidity level is 70% RH, the ON-time for the pump will be:

$$T(\text{on}) = 5 \times (1 - (70 - 80 + 20)/20) = 5 \times (1 - 0,50) = 2,50 \text{ min.}$$

ML TS-PT1000 Temperature sensor	Technical data		
	TD136GB-00	15-03-11	MLK/KK

- TS-PT1000 is a PT1000 temperature sensor mounted in stainless steel AISI304 housing
- M12 sensor connector.
- Accuracy: +/-0.3 °C @ 0 °C
 +/-0.7 °C @ 80 °C
- 3 types of thread available:
 - M6
 - 1/8" pipe thread
 - 1/4" pipe thread



Connection

PT1000 sensor element:

pin:

pin numbering, M12 socket

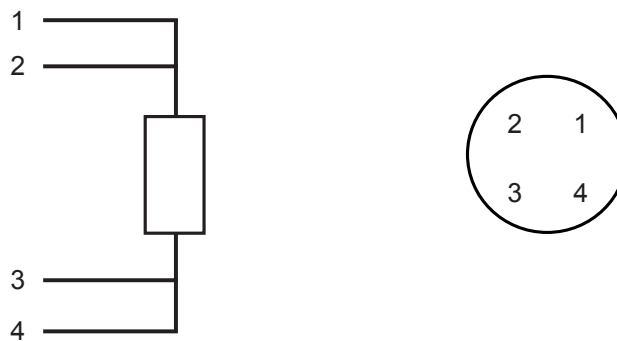

Environment:

Degree of protection:	IP65 (IEC 60529) installed with correct M12 connector
Temperature, operation:	-30 °C to 80 °C
Temperature, stock:	-30 °C to 85 °C

Mechanical specifications

Length:	41.7 mm
Hex width, M6 & 1/8":	14 mm
Hex width, 1/4":	19 mm
Material, housing:	Stainless steel, AISI 304
Material, M12 socket:	Noryl, black
Weight:	M6 & 1/8": 12 g. 1/4": 21 g.

Accessories

2 m cable with M12 connector
Gasket

Note: cable colours: 1 = brown; 2 = white; 3 = blue; 4 = black

Electrical settings in the Humidity Regulator

Technical data

TI031GB-01

27.11.15

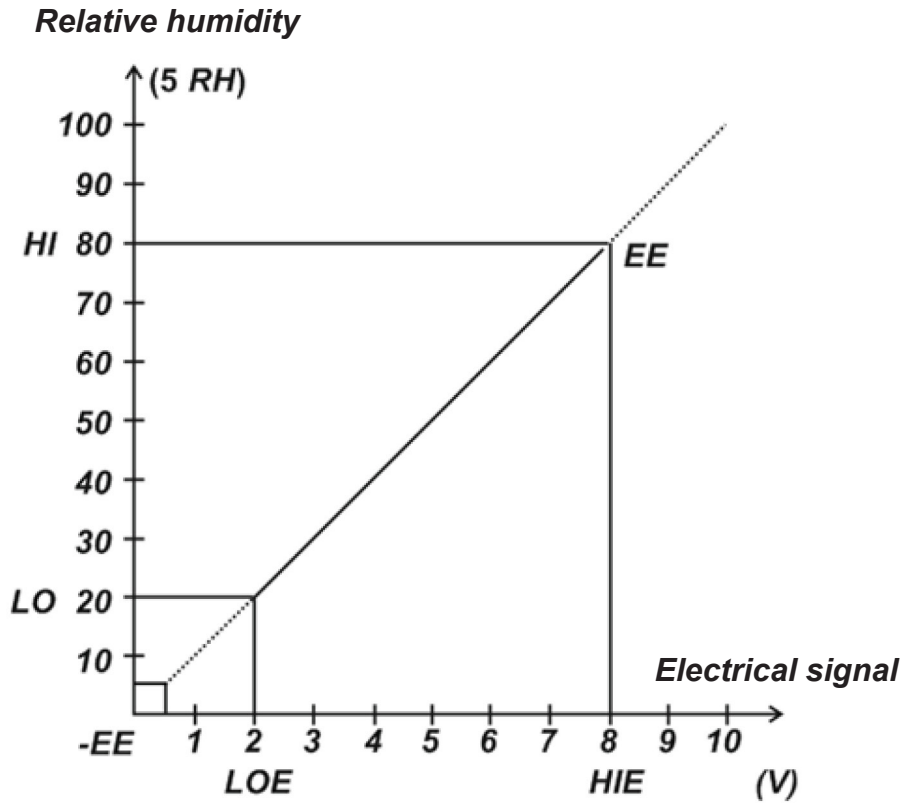

LAA/KK



- HIE: Highest electrical input
- LOE: Lowest electrical input
- HI: Highest reading in display
- LO: Lowest reading in display

0-10 minutes after switch on LOE is 0.5 V and LO is 5 % RH
 After 10 minutes LOE changes to 2 V and LO to 20 % RH

Overview of calibration for conductivity sensors and converters (amplifiers)

Sensor	Converter	Item: CS-100	Item: CS-101	Item: CS-110	Item: CS-111	Item: CS-120	Item: CS-121
		Conductivity sensor std. sensitivity ML nr: 655.050.023	Conductivity sensor high sensitivity ML nr: 655.050.026	Conductivity sensor, std. sens. long ML nr: 655.050.024	Conductivity sensor, high sens. long ML nr: 655.050.027	Conductivity sensor std. sens. 3/4" ML nr: 655.050.029	Conductivity sensor high sens. 3/4" ML nr: 655.050.028
		Range: 0-60 μ S HIE - 10.00 Volt LOE - 0.00 Volt HI - 60 μ S LO - 0 μ S	Range: 0-20 μ S HIE - 10.00 Volt LOE - 0.00 Volt HI - 20 μ S LO - 0 μ S	Range: 0-60 μ S HIE - 10.00 Volt LOE - 0.00 Volt HI - 60 μ S LO - 0 μ S	Range: 0-20 μ S HIE - 10.00 Volt LOE - 0.00 Volt HI - 20 μ S LO - 0 μ S	Range: 0-45 μ S HIE - 10.00 Volt LOE - 0.00 Volt HI - 45 μ S LO - 0 μ S	Range: 0-20 μ S HIE - 10.00 Volt LOE - 0.00 Volt HI - 20 μ S LO - 0 μ S
		Range: 0-600 μ S HIE - 10.00 Volt LOE - 0.00 Volt HI - 600 μ S LO - 0 μ S	Range: 0-200 μ S HIE - 10.00 Volt LOE - 0.00 Volt HI - 200 μ S LO - 0 μ S	Range: 0-600 μ S HIE - 10.00 Volt LOE - 0.00 Volt HI - 600 μ S LO - 0 μ S	Range: 0-200 μ S HIE - 10.00 Volt LOE - 0.00 Volt HI - 200 μ S LO - 0 μ S	Range: 0-450 μ S HIE - 10.00 Volt LOE - 0.00 Volt HI - 450 μ S LO - 0 μ S	Range: 0-200 μ S HIE - 10.00 Volt LOE - 0.00 Volt HI - 200 μ S LO - 0 μ S
		ML - CMR ML nr. 655.010.050	ML - CMR ML nr. 655.010.052				
							

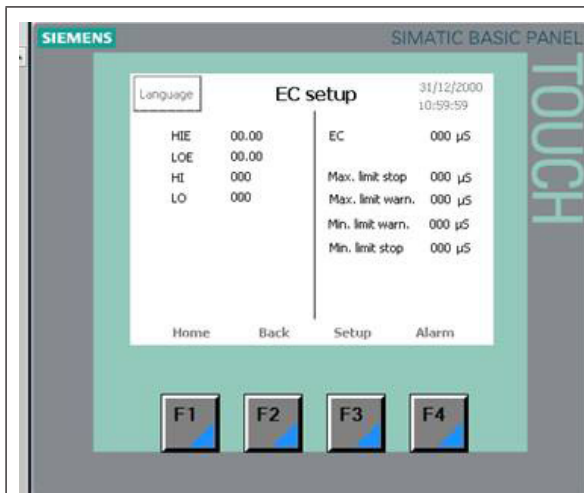

HIE, Input standard values, from chart, Overview of calibration for conductivity sensors and converters (amplifiers)

LOE, Input standard values, from chart, Overview of calibration for conductivity sensors and converters (amplifiers)

HI, Input standard values, from chart, Overview of calibration for conductivity sensors and converters (amplifiers)

LO, Input standard values, from chart, Overview of calibration for conductivity sensors and converters (amplifiers)

If the sensor needs calibration, adjust HI up or down until EC value is correct

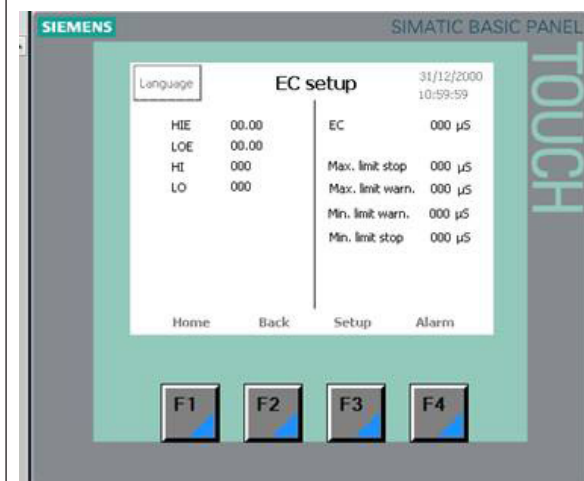

Setting the Alarm's and Warnings example, this sensor is chosen :

HIE	-	10.00 Volt
LOE	-	0.00 Volt
HI	-	60 µS
LO	-	0 µS

Max limit stop 50 µS
 Max limit warn 40 µS
 Min. Limit warn 10 µS
 Min. Limit stop 5 µS

This setting vil give a warning if µS value goes to 40 or 10 µS and stop the pump if µS value goes to 50 or 5 µS

Max limit stop 100 µS
 Max limit warn 40 µS
 Min. Limit warn 10 µS
 Min. Limit stop 0 µS

This setting vil give a warning if µS value goes to 40 or 10 µS and newer stop the pump

Water softener MACH 2030, 2060, 2100 & CP 213S

A. Installation instructions

1. Remove the cardboard packaging from the individual parts.
2. The system consists of two filters, a salt reservoir, drain/salt hoses as well as connecting pieces incl. O-rings and silicone.



3. Fit the enclosed O-rings on the black plastic/brass connecting pieces and lubricate with silicone from the small tube. Then install the connecting pieces shown in the pictures below.



4. Make sure there are no mechanical impurities following the installation work. If necessary, flush the pipework before installing the system.
5. Install the drain hose on the head of the water softener in the associated drain connector and tighten the by hand, see below.



1. Outlet, soft water
2. Inlet, raw water
3. Tube for floor drain (thick, transparent)
4. Tube for salt reservoir (thin, black)
5. Connecting pieces

6. Connect the salt hose to the water softener head in the associated pipe connection and tighten the nut by hand. The drain hose and the salt hose must not be exchanged as they have individual dimensions.
7. Then install pressure hoses for raw water and soft water outlet, respectively, on the system (1 and 2 in the photo above).

8. Lead the drain hose to the floor drain.
9. The salt reservoir is provided with an overflow connector which is lead to the floor drain.



10. The system is now ready for start-up.

Note: There must always be a floor drain to avoid damage caused by leakage.

B. Start-up procedure

1. Check that the number on the standard-installed meter disc corresponds to the hardness on site. If not, the meter disc must be replaced. Order the correct meter disc from KINETICO or from your supplier.

Adjustment of salt valve in salt reservoir

2. To obtain the right setting of the adjustment tube, a certain number of tabs must be removed (the yellow plastic part in the photo to the right). This is done using a sharp knife, removing the tabs individually with the knife – cut in the longitudinal direction under the tabs. Keep the number or letter that is to be the setting point as the top tab.
3. Adjust the float in the following manner: the numbers for the float are indicated on the adjusting rod (photo to the right). The top edge of the float must be aligned with the number strip. (Note: with CP 213s, the bottom edge of the float applies). The holder of the salt valve must be positioned horizontally above the valve and the adjusting rod must be parallel with the valve tube, i.e. the adjusting pipe must not be twisted.



4. When installing the salt valve, be careful not to drop it down into the cylinder. If it is dropped, the float may sink and give an incorrect setting. Place the valve in such a way that the bent 3/8" pipe is placed along the back of the salt well away from the cylinder wall. Now press the 3/8" bent pipe into the notch, so that it extends 25 mm from the brine cylinder (see photo to the right).



5. The valves and the outlet sides and the bypass valve (if installed) must be closed.

6. Open the valves on the inlet sides slightly so that the filter slowly fills with water. At the same time, the brine tank will be filled with water by means of the brine valve.

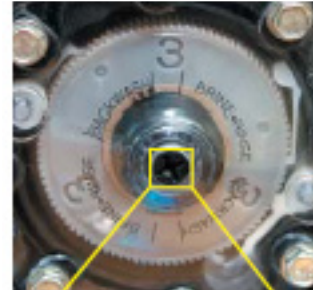

7. First, set one and then the other tank in backwash mode for a while to vent any air from the system. Do this by pressing down the Phillips screw at the centre of the automatics while turning it clockwise. Check that the water runs out of the outlet hose to the drain.

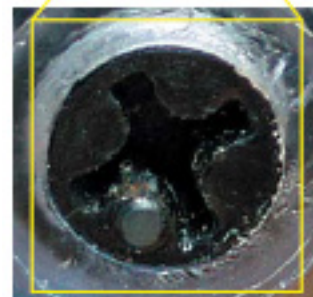

8. When any air has been vacated from the system, start the filter (black dot, 12 or 6 o'clock position) by turning Phillips screw again.

9. Then open the valve on the outlet and inlet side fully.

10. Check that the water runs into the salt container vat until the brine valve on the tank closes. Check that the water is above the mesh plate.

11. Fill the tank with salt tablets.

12. Normally, there must be so much salt in the salt reservoir that the water is completely covered - top up with salt.

13. The system is now ready for operation and will produce softened water right away.

DECLARATION OF CONFORMITY FOR CE CERTIFICATION

In Accordance to ISO/IEC Guide 22

For

WATER SOFTENING UNITS

MANUFACTURER: Kinetico Incorporated
10845 Kinsman Road
Newbury, OH 44065
Phone: 440.564.9111 Fax: 440.564.4407

MODEL NUMBERS: 2020C, 2025S, 2030S, 2050S, 2060S, 2100S, 2175S,
4050S, 2060S OD, 2100S OD, HT613, HT618, HT621,
CC206C, CC208C, 2175S, CP213S OD, CP216S OD

REPORT NUMBERS: AAAQ1594-01S

DIRECTIVE: Low Voltage Directive (72/23/EEC), 1973; including
Amendment (93/68/EEC), 1993

STANDARD: EN 14743 – Water Equipment Inside Buildings: Softeners –
Requirements for Performance, Safety and Testing

TEST FACILITY: F-Squared Laboratories
26501 Ridge Rd.
Damascus, MD 20872

The water softening units, model numbers 2020C, 2025S, 2030S, 2050S, 2060S, 2100S, 2175S, 4050S, 2060S OD, 2100S OD, HT613, HT618, HT621, CC206C, CC208C, 2175S, CP213S OD, CP216S OD are in effective conformance to the Directive and Standard referenced above.

Authorized By:



Thomas P. Goshe
Standards and Regulatory Compliance Manager
Kinetico Incorporated
June 10, 2010

ML-system - Condair a/s

Monitoring of humidity and status signals:

As an option the PLC system can through an integrated website be connected to the customer's computer over TCP/IP so that the client can access a page, that shows the status of the system with monitoring of the current humidity in each section.

This page can be opened with most standard browsers - We have tested.

The website in the PLC:

The screenshot displays the webserver interface for the MLPRO 100-800 system. The header includes the product name and the Condair logo. A left sidebar contains contact information. The main content area shows the system overview with a refresh instruction and two data sections: Pump system value and Humidity section.

MLPRO 100-800
Webserver Applikation

condair

Condair A/S
Parallelvej 2
8680 Ry - DK
Tlf: +45 87882100
mail: condair.dk@condair.com
www: condairsystems.com

Overview System - ** Update by pressing F5 **

Pump system value
Current flow: 650 l/h
Tank Level: 20 liter
Operation warning!

Humidity section
Section 1: 31 %RH
Section 2: 32 %RH
Section 3: 33 %RH
Section 4: 34 %RH
Section 5: 35 %RH
Section 6: 36 %RH
Section 7: 37 %RH
Section 8: 38 %RH

ML-system - Condair a/s

The system displays the current humidity as the page opens - most browsers will then update every 10 seconds. - But you can also manually refresh at any movement by pressing F5.

Also shown is a pump station operating status:

- Humidification stopped
- Humidification active
- One or more operating warnings – System still running
- One or more operating alarms – System stopped

In order to obtain access to the data, use an Ethernet connection directly to the PLC system data switch located in the control cabinet to the left of the PLC system.

Use a standard web browser and enter the PLC fixed IP address xxx.xxx.xxx.xxx in the address field. This can be done through the company's internal Ethernet network – with separate cable or with a laptop directly into the switch. Perhaps, use a router to get going at this address.

(It is important here to remember that the PC must be located in the same virtual network as the PLC does).



ML-system - Condair a/s

After entering the correct IP address - the following picture appears. Start by downloading and installing Siemens security certificate (download and follow the onscreen instructions). Then press Enter

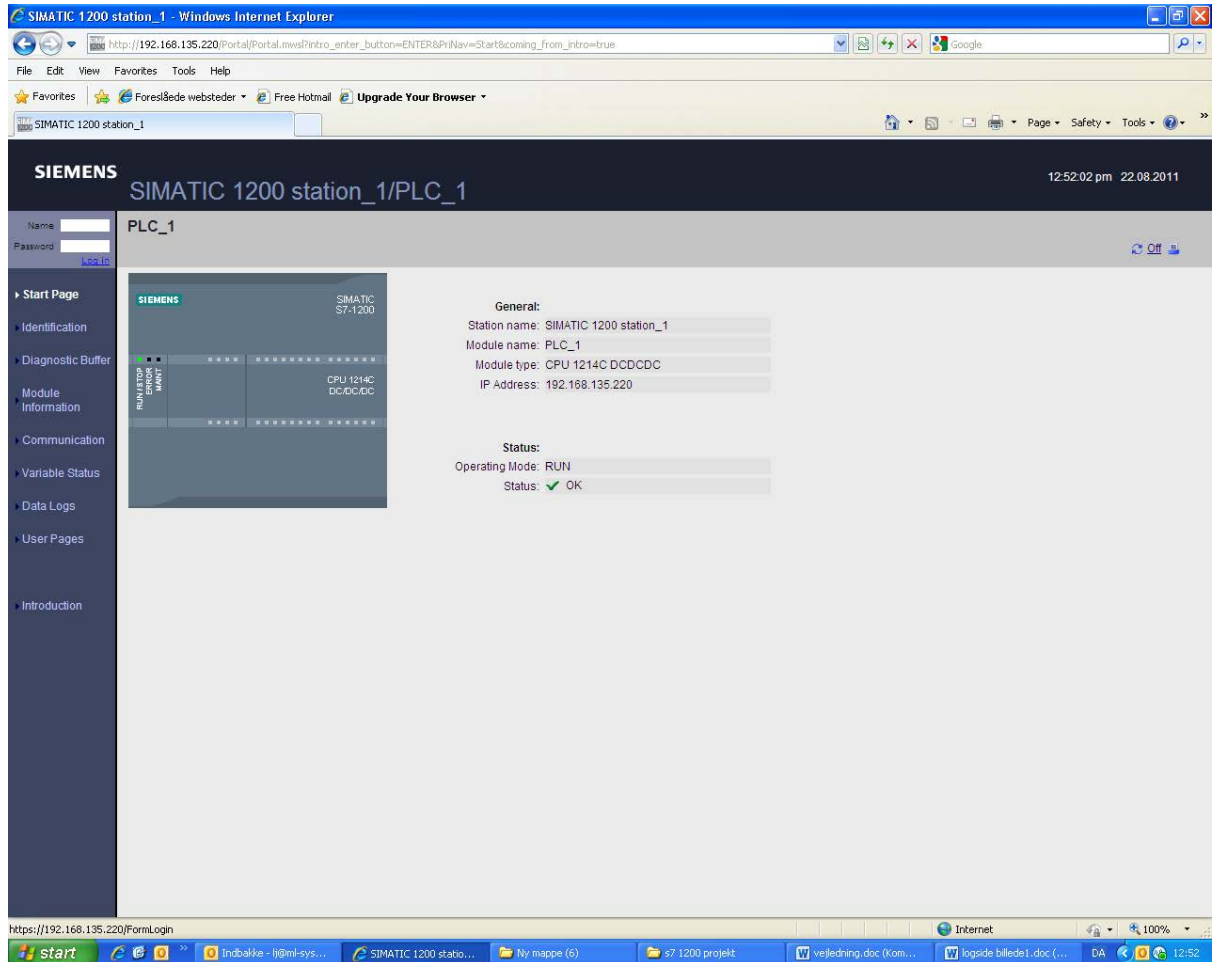

Press User Pages in the boxes in left side of the screen

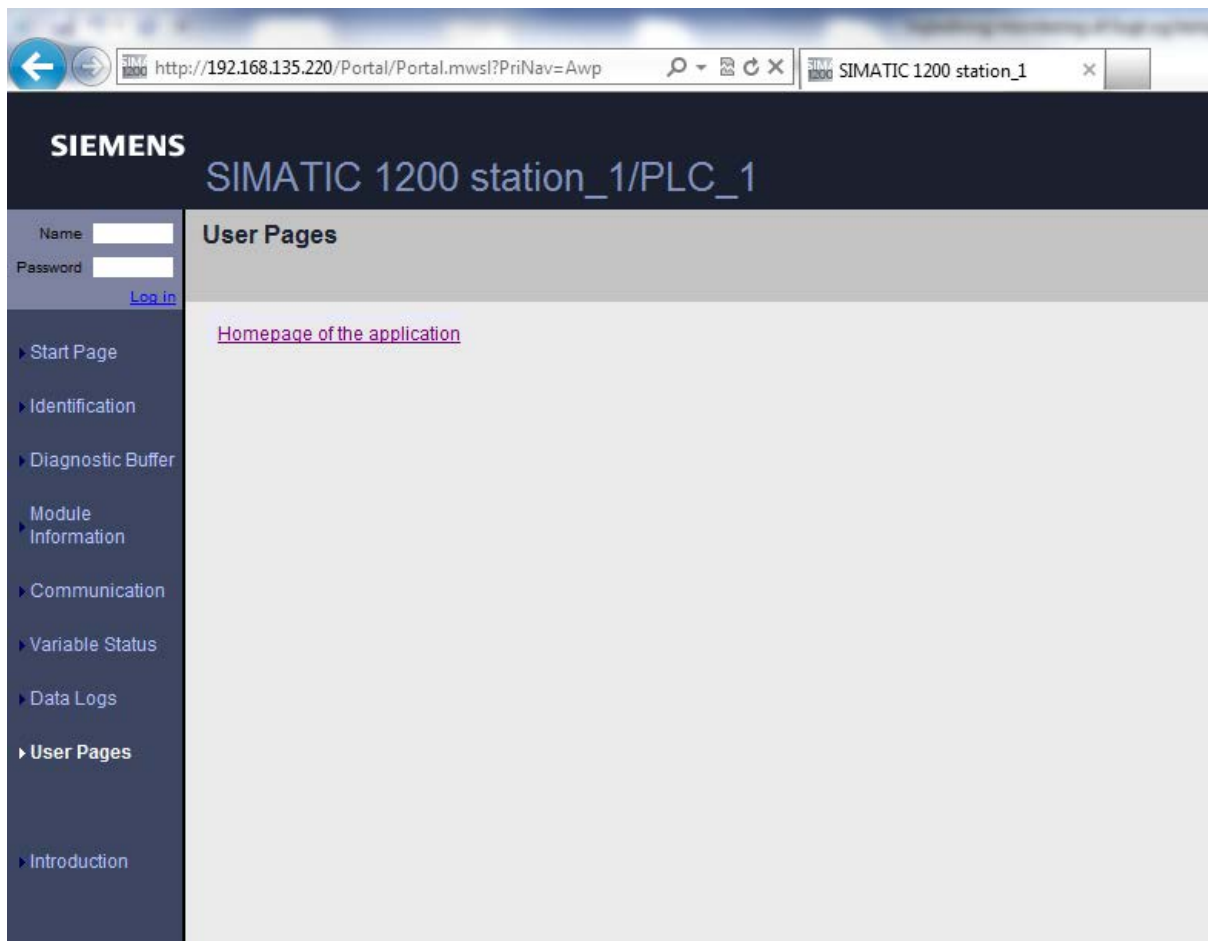

Press on the Home Page of the application

The website now opens and update.

To make future connections easier, make a shortcut for example to your desktop

CONSULTING, SALES AND SERVICE:

Condair A/S
Parallevej 2, DK-8680 Ry
Phone +45 8788 2100
condair.dk@condair.com, www.condair.dk

