

INSTALLATION MANUAL

Pure Water System
Condair **RO-E**

Thank you for choosing Condair

Installation date (MM/DD/YYYY):

Commissioning date (MM/DD/YYYY):

Site:

Model:

Serial number:

Proprietary Notice

This document and the information disclosed herein are proprietary data of Condair Group AG. Neither this document, nor the information contained herein shall be reproduced, used, or disclosed to others without the written authorization of Condair Group AG, except to the extent required for installation or maintenance of recipient's equipment.

Liability Notice

Condair Group AG does not accept any liability due to incorrect installation or operation of the equipment or due to the use of parts/components/equipment that are not authorized by Condair Group AG.

Copyright Notice

© Condair Group AG, All rights reserved.

Technical modifications reserved

Contents

1	Introduction	5
1.1	Read me first!	5
1.2	Notes on the installation manual	5
2	For your safety	7
2.1	General safety guidelines	7
2.2	Intended use	7
2.3	Danger that may arise from the Condair RO-E(+) pure water system	8
2.4	Ensure safe installation	9
2.5	Hygiene	9
3	Product Overview	10
3.1	Product overview Condair RO-E pure water systems	10
3.1.1	Model overview Condair RO-E pure water systems	10
3.2	Which RO-E pure water system for which Condair isothermal humidifier	12
3.3	Product overview Condair RO-E+ pure water systems	13
3.3.1	Model overview Condair RO-E+ pure water systems	13
3.4	Which RO-E+ pure water system for Condair adiabatic humidification systems	15
3.5	Product designation	15
3.6	Available options	16
3.7	Available accessories	17
3.8	System overview	19
4	Important notes	21
4.1	Inspection of the delivery	21
4.2	Storage and Transportation	21
5	Mounting and installation work	22
5.1	Safety notes on mounting and installation work	22
5.2	Requirements on siting and installation	23
5.3	Positioning the Condair RO-E(+) pure water system components	25
5.3.1	Mounting of the pre-filter	29
5.3.2	Positioning the optional water softener and the 5 µm filter (if applicable)	30
5.3.3	Positioning the Condair RO-E(+) pure water system	30
5.3.4	Positioning the external pressure tank(s)	31
5.3.5	Mounting the external control unit (for stand alone systems only)	31
5.3.6	Mounting of the pressure tank safety valve for Condair RO-E(+) 40/100 and Condair RO-E 200/300	31
5.3.7	Mounting of the pressure tank safety valve for RO-E+ 200/300	32
5.4	Water installation	33
5.4.1	Principal water installation for Condair RO-E 40/100 without pressure tank safety valve	33
5.4.2	Principal water installation for Condair RO-E 40/100 with pressure tank safety valve (e.g. CE certified systems)	34
5.4.3	Principal water installation for Condair RO-E 200/300 without pressure tank safety valve	35
5.4.4	Principal water installation for Condair RO-E 200/300 with pressure tank safety valve (e.g. CE certified systems)	36
5.4.5	Principal water installation for Condair RO-E+ 40/100 without pressure tank safety valve	37
5.4.6	Principal water installation for Condair RO-E+ 40/100 with pressure tank safety valve (e.g. CE certified systems)	38
5.4.7	Principal water installation for Condair RO-E+ 200/300 without pressure tank safety valve	39
5.4.8	Principal water installation for Condair RO-E+ 200/300 with pressure tank safety valve (e.g. CE certified systems)	40
5.4.9	Supply water requirements for the Condair RO-E(+) pure water system	41

5.4.10	Material specifications water installation	42
5.4.11	Important notes on water installation	42
5.4.12	Notes on supply water line	43
5.4.13	Notes reverse osmosis water line	43
5.4.14	Notes on drain lines	44
5.4.15	Connection of the external pressure tank(s) to the Condair RO-E(+) pure water system	45
5.4.16	Connecting the optional pressure tank safety valve	50
5.4.16.1	Connecting the pressure tank safety valve to the Condair RO-E(+) 40/100 pure water systems	51
5.4.16.2	Connecting the pressure tank safety valve to the Condair RO-E+ 200/300 pure water systems	53
5.4.16.3	Connecting the pressure tank safety valve to the Condair RO-E 200/300 pure water systems	55
5.5	Electrical installation	57
5.5.1	Notes on electrical installation	57
5.5.2	Electrical connections of the water softeners	58
5.5.3	Electrical connections of the Condair RO-E(+) pure water system	59
6	Product specification	67
6.1	Technical data	67
6.1.1	Technical data RO-E(+) pure water system	67
6.1.2	Internal pressure tank 25 l for Condair RO-E(+) 40 & 100	68
6.1.3	External pressure tank 140 l for Condair RO-E+	68
6.1.4	External pressure tank 112 l for Condair RO-E 200/300	69
7	Appendix	70
7.1	Dimensional drawing Condair RO-E(+) pure water system	70
7.2	Dimensional drawing external pressure tank 140 l	71
7.3	Dimensional drawing external pressure tank 112 l	72
7.4	Wiring diagram Condair RO-E(+) pure water system - 230 V	73
7.5	Wiring diagram Condair RO-E(+) pure water system - 110 V	74
7.6	Hydraulic diagram Condair RO-E pure water system	75
7.7	Hydraulic diagram Condair RO-E+ pure water system	76

1 Introduction

1.1 Read me first!

Thank you for choosing the **Condair RO-E(+) pure water system**.

The Condair RO-E(+) pure water system incorporates the latest technical advances and meets all recognized safety standards. Nevertheless, improper use of the Condair RO-E(+) pure water system may result in danger to the user or third parties and/or damage to property.

To ensure a safe, proper, and economical operation of the Condair RO-E(+) pure water system, please observe and comply with all information and safety instructions contained in the present documentation as well as in the separate documentations of the components used together with the Condair RO-E(+) pure water system

If you have questions after reading this documentation, please contact your Condair representative. They will be glad to assist you.

1.2 Notes on the installation manual

Scope

The subject of this installation manual is the Condair RO-E(+) pure water system in the various versions. Additional system components as well as options and accessories are only described to the extent necessary for proper installation. For more information about the options and accessories, please refer to the respective instructions.

The information provided in this installation manual is limited to the **installation** of the Condair RO-E(+) pure water system and is intended for **well-trained specialist personnel who are sufficiently qualified for the respective work**.

This installation manual is supplemented by other documents (e.g. operation manual, spare parts list, etc.). Where necessary, cross-references to these publications can be found in this installation manual.

Use of model designation

The model designations are used in this installation manual as follows:

- **RO-E:** If the model designation "RO-E" is used in texts, the corresponding instruction text **only applies to the RO-E model series**.
- **RO-E+:** If the model designation "RO-E+" is used in texts, the corresponding instruction text **only applies to the RO-E+ model series**.
- **RO-E(+):** If the model designation "RO-E(+)" is used in texts, the corresponding instruction text applies to **both model series** (RO-E and RO-E+).

Conventions



CAUTION!

The catchword "**CAUTION**" used in conjunction with the general caution symbol designates notes in this manual that, if neglected, may cause **damage and/or malfunction of the unit or damage to property**.



WARNING!

The catchword "**WARNING**" used in conjunction with the general caution symbol designates safety and danger notes in this manual that, if neglected, may cause **injury to persons**.



DANGER!

The catchword "**DANGER**" used in conjunction with the general caution symbol designates safety and danger notes in this manual that, if neglected, may lead to **severe injury or even death of persons**.

Definitions

– **Raw water:**

The term raw water refers to (untreated) drinking, or tap water without any additives like chlorine, H₂O₂, ozone, etc.

– **Soft water:**

Soft water is the term applied to water produced by the water softener unit. The water softening process replaces hard ions from calcium and magnesium with sodium.

– **Pure water (reverse osmosis water):**

The term pure water or reverse osmosis water (RO water) refers to water partially dematerialized by the Condair RO-E(+) pure water system.

Safekeeping

Please safeguard this installation and installation manual in a safe place, where it can be immediately accessed. If the equipment changes hands, this installation manual must be passed on to the new operator.

If the installation manual gets misplaced, please contact your Condair representative.

Language versions

This installation manual is available in other languages. Please contact your Condair representative for information.

2 For your safety

2.1 General safety guidelines

General

Every person carrying out installation work on the Condair RO-E(+) pure water system must have read and understood the installation manual and the operation manual of the Condair RO-E(+) pure water system before carrying out any work.

Knowing and understanding the contents of these manuals is a basic requirement for protecting the personnel against any kind of danger and to prevent faulty installation of the equipment.

All icons, signs and markings applied to the components of the Condair RO-E(+) pure water system must be observed and kept in readable state.

Qualification of personnel

All work described in this installation manual may only be carried out by trained and sufficiently qualified personnel authorized by the owner. It is the owner's responsibility to verify proper qualification of the personnel.

For safety and warranty reasons any action beyond the scope of this manual must only be carried out by a Condair service technician or trained personnel authorized by Condair.

It is assumed that all persons working with the Condair RO-E(+) are familiar and comply with the appropriate regulations on work safety and the prevention of accidents.

2.2 Intended use

The Condair RO-E pure water system is intended exclusively for the production of pure water for feeding isothermal humidification systems and the Condair RO-E+ pure water system is intended exclusively for the production of pure water for feeding Condair adiabatic humidification systems within the specified operating conditions. Any other use without the written consent of Condair, is considered as not conforming with the intended purpose and may lead to the Condair RO-E(+) pure water system becoming dangerous and will void any warranty.

The intended use also includes observing **all information contained in this installation manual as well as in the operation manual of the Condair RO-E(+) pure water system (in particular the safety instructions).**

2.3 Danger that may arise from the Condair RO-E(+) pure water system



DANGER!
Risk of electric shock!

The Condair RO-E(+) pure water system is mains powered. Live parts may be exposed when the control compartment or the terminal box of the pump motors/are open. Touching live parts may cause severe injury or danger to life.

Prevention: Before carrying out any work on the components of the Condair RO-E(+) pure water system make sure the system is disconnected from the mains and secured against inadvertent power-up.

Important: The frequency converter in the Condair RO-E(+) pure water system contains capacitors. These can remain charged with a potentially deadly voltage for a certain period of time after the Condair RO-E(+) pure water system has been disconnected from the power supply. Therefore, wait at least 10 minutes after disconnecting the power supply. Then make sure the appropriate contacts on the frequency converter and the terminals on the pump motor are free of voltage before starting any work on these components!



DANGER!
Health risk because of inadequate hygiene!

Inadequately operated and/or poorly maintained pure water systems may endanger health.

Prevention: The Condair RO-E(+) pure water system must strictly be operated and maintained in accordance with this manual.



CAUTION!

Do not use oil, grease, glue, Teflon, silicone, O-ring lubrication, etc. when assembling pipes or hose connections. All of these products can lead to the growth of bacteria and thus pose health risks.

Only approved lubricant is: **Dishwashing liquid.**

Always wash your hands and wear clean disposable gloves while assembling parts in direct contact with water.

Do not remove dust protection caps on pipe and hose ends until just before assembly.

When fitting water filters, RO membranes, hoses and other components in direct contact with water, wash your hands and wear sterile disposable gloves or touch only the packing foil to keep the filter and RO membranes bacteria-free.



WARNING!

Water produced from a Condair RO-E(+) pure water system is very aggressive and can cause metals to corrode quickly. The Condair RO-E(+) pure water system should always be connected to piping / equipment suitable for handling reverse osmosis water.

2.4 Ensure safe installation

Observe all local safety standards

Observe all local safety standards regarding the installation of **mains-powered electrical and electronic devices** and **low-pressure water systems**.

Preventing dangerous situations

All persons working on the Condair RO-E(+) pure water system are obliged to immediately report any alterations to the system that may affect safety to the responsible person of the owner and to secure the Condair RO-E(+) pure water system against unintentional activation.

Prohibited modifications to the unit

No modifications must be undertaken on the Condair RO-E(+) pure water system without the express written consent of Condair.

For the replacement of defective components use exclusively **original accessories and spare parts** available from your Condair representative.

2.5 Hygiene

Please observe the local health and safety executive's technical guidance on the control of Legionellosis in water systems.

The installer is responsible for ensuring that the water system complies with local regulations, bylaws and guidelines (such as the HSE ACoP L8, VDI 6022, ISO 22000, HACCP or equivalent).

The Condair RO-E(+) pure water system is produced according to best hygiene standards, which means that we have considered all aspects of this equipment to reduce the risk of Legionnaires' disease and other similar conditions. However, the operator is responsible for ensuring that the installation is performed in a manner, ensuring that the system stays clean!

Any risks or hazards relating to the system, including during installation, should be identified by a competent health and safety representative who is responsible for introducing effective control measures.

Observe and follow all hygiene instructions in the Condair RO-E(+) pure water system operation manual.



DANGER!

The Condair RO-E(+) pure water system must be installed in accordance with this manual. Failure to do so could result in contamination that might cause Legionnaires' disease, which can be fatal.

3 Product Overview

3.1 Product overview Condair RO-E pure water systems

3.1.1 Model overview Condair RO-E pure water systems

The Condair RO-E pure water system is designed for the production of **reverse osmosis water for Condair isothermal humidifiers** and is available in **4 models** with different maximum pure water output. All four models have the same housing and the same electrical parts.

All systems can be operated as **stand-alone systems** controlled via the external control unit (supplied with stand-alone systems). Together with the Condair RS steam humidifier, the Condair RO-E can also be operated as **integrated system**, controlled via the integrated control unit of the Condair RS.

	Model			
	RO-E 40	RO-E 100	RO-E 200	RO-E 300
Pure water output ¹⁾ at 10°C against 3 bar	61 l/hr	152 l/hr	303 l/hr	350 l/hr ²⁾
Pure water output ¹⁾ at 10°C against 1 bar	78 l/hr	183 l/hr	350 l/hr ²⁾	350 l/hr ²⁾
Pure water output ¹⁾ at 15°C against 3 bar	72 l/hr	180 l/hr	350 l/hr ²⁾	350 l/hr ²⁾
Pure water output ¹⁾ at 15°C against 1 bar	92 l/hr	218 l/hr	350 l/hr ²⁾	350 l/hr ²⁾
RO membrane type	1x 14"	1x 21"	2x 21"	3x 21"
Pressure tank	internal		external	
Nominal volume	25 l		112 l	
Usable volume at 5 bar	18 l		79 l	

- ¹⁾ Performance data valid at:
- | | |
|----------------------------|--------------------|
| Water temperature | according to table |
| Tank back pressure | according to table |
| Pump pressure RO-E 40 | 10 bar |
| Pump pressure RO-E 100-300 | 12 bar |
| Inlet water quality | Softened water |

Note: The pure water output rates are theoretically calculated values that may differ from reality. To avoid shortening the membrane lifespan, the purified water flow rate should not be set higher than specified for the respective Condair RO-E (e.g. RO-E 300 = approx. 300 l/hr).

- ²⁾ Maximum possible pure water output due to the pump performance.

RO-E 40

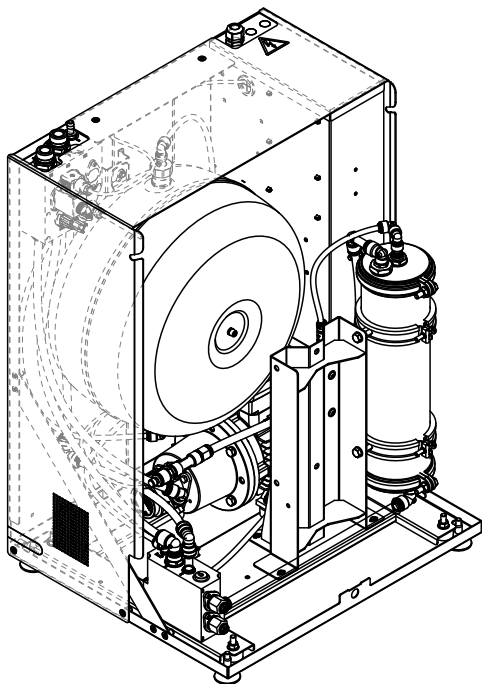

RO-E 100

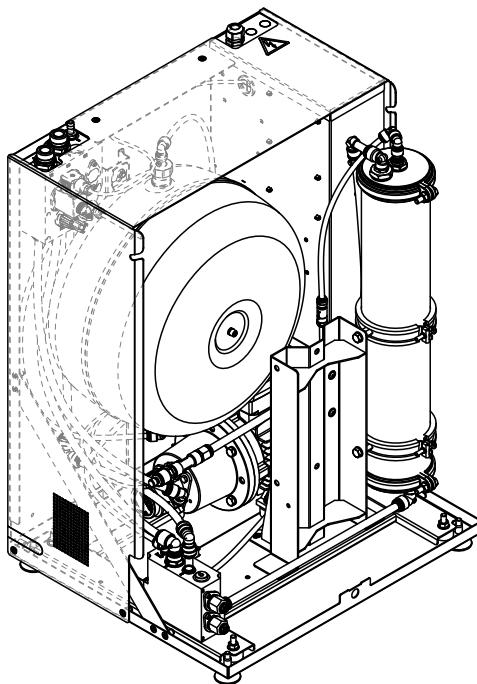

RO-E 200

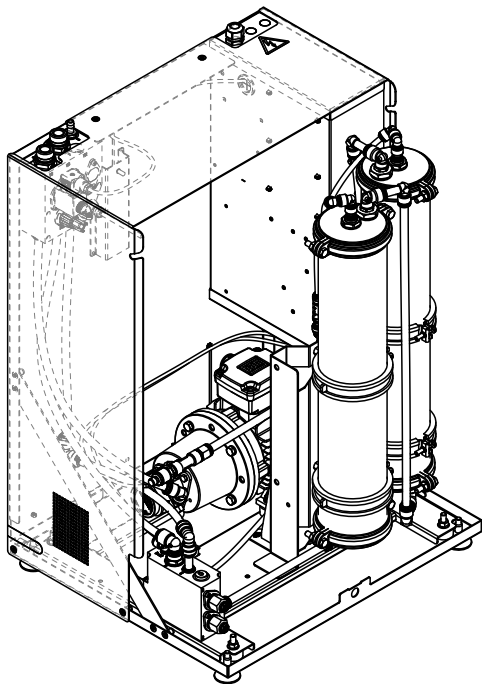

RO-E 300

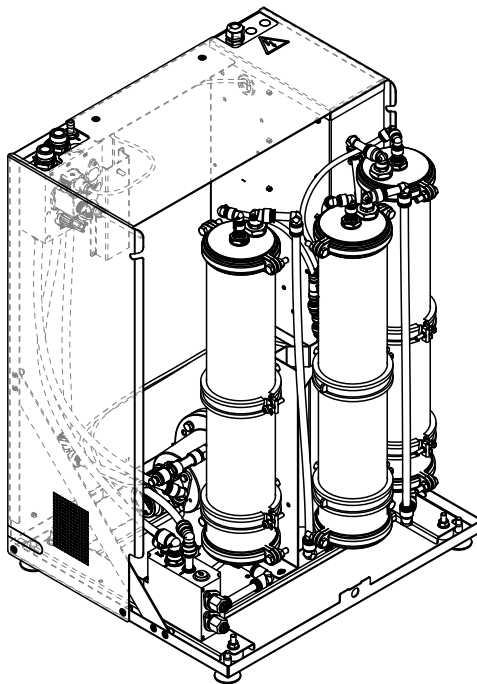

3.2 Which RO-E pure water system for which Condair isothermal humidifier

Condair device	Nominal capacity in kg/h	RO-E Type	Usable volume pressure tank at 5 bar	
			internal	external
RS / Omega Pro				
5 (Single unit "S")	5	RO-E 40	18 l	---
8 (Single unit "S")	8	RO-E 40		
10 (Single unit "S")	10	RO-E 40		
16 (Single unit "M")	16	RO-E 40		
20 (Single unit "M")	20	RO-E 40		
24 (Single unit "M")	24	RO-E 40		
30 (Single unit "M")	30	RO-E 40		
40 (Single unit "M")	40	RO-E 40		
50 (Single unit "L")	50	RO-E 100		
60 (Single unit "L")	60	RO-E 100		
80 (Single unit "L")	80	RO-E 100		
40 (Double unit "2xM")	40	RO-E 40		
50 (Double unit "2xM")	50	RO-E 100		
60 (Double unit "2xM")	60	RO-E 100		
100 (Interconnected devices "3xM")	100	RO-E 100	---	79 l
120 (Interconnected devices "3xM")	120	RO-E 200		
140 (Interconnected devices "4xM")	140	RO-E 200		
160 (Interconnected devices "4xM")	160	RO-E 200		

GS				
23	23	RO-E 40	18 l	---
45	45	RO-E 40 or RO-E 100		
65	65	RO-E 100		
90	90	RO-E 100		
130	130	RO-E 200	---	79 l
195	195	RO-E 300		
260	260	RO-E 300		

3.3 Product overview Condair RO-E+ pure water systems

3.3.1 Model overview Condair RO-E+ pure water systems

The Condair RO-E+ pure water system is designed for the production of **reverse osmosis water for Condair adiabatic humidifiers** and is available in **4 models** with different maximum pure water output. All four models have the same housing and the same electrical parts.

All systems can be operated as **stand-alone systems** controlled via the external control unit (supplied with stand-alone systems). Together with the Condair RS steam humidifier, the Condair RO-E can also be operated as **integrated system**, controlled via the integrated control unit of the Condair RS.

	Model			
	RO-E+ 40	RO-E+ 100	RO-E+ 200	RO-E+ 300
Pure water output ¹⁾ at 10°C against 3 bar	34 l/hr	90 l/hr	180 l/hr	270 l/hr
Pure water output ¹⁾ at 10°C against 1 bar	44 l/hr	108 l/hr	218 l/hr	325 l/hr
Pure water output ¹⁾ at 15°C against 3 bar	40 l/hr	107 l/hr	215 l/hr	320 l/hr
Pure water output ¹⁾ at 15°C against 1 bar	52 l/hr	130 l/hr	260 l/hr	350 l/hr ²⁾
RO membrane type	1x 14"	1x 21"	2x 21"	3x 21"
Nominal volume pressure tank	internal ³⁾		external ⁴⁾	
Usable volume pressure tank at 5 bar	25 l 18 l		140 l 102 l	

¹⁾ Performance data valid at:

Water temperature	according to table
Tank back pressure	according to table
Pump pressure RO-E+ 40	10 bar
Pump pressure RO-E+ 100-300	12 bar
Inlet water quality	Softened water

Note: The pure water output rates are theoretically calculated values that may differ from reality. To avoid shortening the membrane lifespan, the purified water flow rate should not be set higher than specified for the respective Condair RO-E (e.g. RO-E+ 300 = approx. 300 l/hr).

²⁾ Maximum possible pure water output due to the pump performance.

³⁾ Models with internal pressure tank. Up to 3 **additional** external pressure tanks available as accessory (see [Section 3.7](#)) can be connected.

⁴⁾ Up to 3 external pressure tanks available as accessory (see [Section 3.7](#)) can be connected.

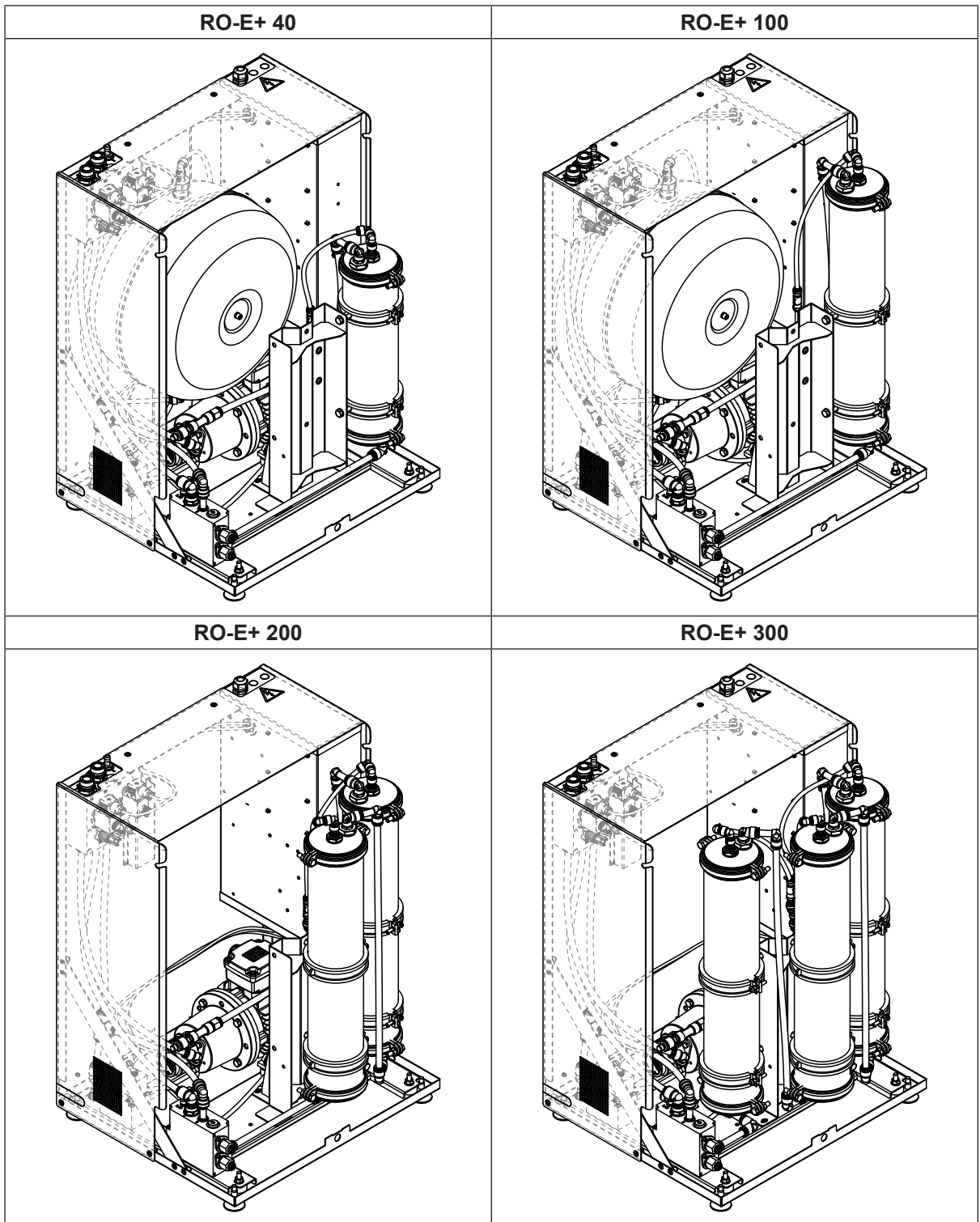

3.4 Which RO-E+ pure water system for Condair adiabatic humidification systems

The Condair RO-E+ pure water system for Condair adiabatic humidification systems (Condair DL or Condair ME) must be selected based on the required humidification capacity. For Condair DL or Condair ME systems with a humidification capacity >300 l/hr an appropriate Condair RO DL or Condair ML RO pure water system must be used.

3.5 Product designation

The product designation and the most important unit data are found on the rating plate fixed on the top side and the back side of the Condair RO-E(+) pure water system (see example below):

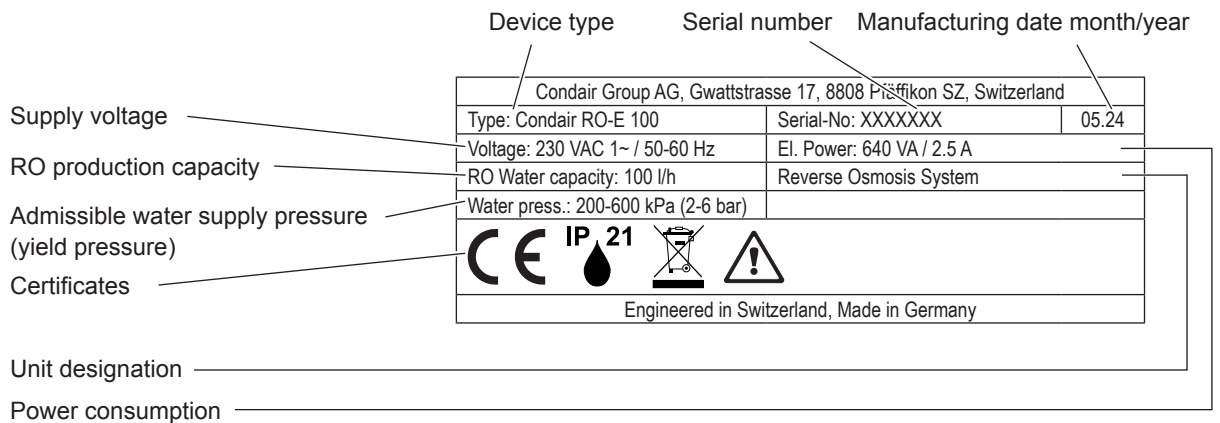

3.6 Available options

Option	Description	RO-E	RO-E+
Cover (CO)	Cover for RO-E(+). Note: The cover is supplied as standard in some countries.	X	X
Soundproof cover (CONI)	Soundproof cover for RO-E(+).	X	X
Outlet valve permeate Y13 (OV)	Outlet valve Y13 (NO) for controlling the permeate outlet.	X	X
Drain valve Y12 (DV)	Drain valve Y12 (NO) for controlling the draining and flushing of the internal water system. Note: The drain valve Y12 is installed as standard in Condair RO-E+ pure water systems.	X	—
Volume flow measuring (VF)	Sensor for measuring the permeate volume flow. The sensor is installed in the outlet line of the membrane(s) and connected to the driver board in the control compartment.	X	X
Pressure gauge pump pressure (PPG)	Pressure gauge for displaying the pump pressure. The pressure gauge is connected to the inlet of the (first) membrane.	X	X
Conductivity measuring (CM)	The conductivity sensor is installed in the standard logic block and connected to the conductivity and temperature in the control compartment. Note: Condair RO-E+ pure water systems have the conductivity measuring installed as standard.	X	—
Conductivity and temperature measuring (CTM)	The conductivity and temperature sensor is installed in the standard logic block and connected to the conductivity and temperature measuring board in the control compartment. Note: Conductivity and temperature measuring option cannot be used together with conductivity measuring (CM option).	X	X
Concentrate valve Y16 (CV)	Concentrate valve Y16 for emptying the membrane(s). The concentrate valve Y16 is installed in the options logic block and connected to the driver board in the control compartment. Note: The concentrate valve Y16 cannot be used with the conductivity adjustment (option CA). Use the CVA option if necessary.	X	X
Conductivity adjustment (CA)	The conductivity adjustment option consists of a throttle valve and a check valve. The conductivity adjustment option is installed in the options logic block. Note: The conductivity adjustment cannot be used with the concentrate valve Y16 (CV option). Use the CVA option if necessary.	X	—
Concentrate valve Y16 and conductivity adjustment (CVA)	Concentrate valve Y16 for draining the membrane(s) and conductivity adjustment consisting of a throttle valve and a check valve. The concentrate valve Y16 and conductivity adjustment are installed in the options logic block.	X	—
Safety valve pressure tank (SV)	External safety valve set with mounting and connection material for reverses osmosis pressure tank. Note: For CE certified system the safety valve set for the reverses osmosis pressure tank is included in the delivery.	X	X

External control unit	<p>The external control unit is used for Condair RO-E(+) stand-alone systems only.</p> <p>The external control unit is equipped with a touch panel to operate the control software, an operation status LED which indicates normal operation (LED lights green), warning (LED lights yellow) and error status (LED lights red). Additionally the external control unit features a USB interface for data logging, exporting service and error histories and updating the control and the driver board software.</p>	X	X
Remote operating and fault indication	<p>The remote operating and fault indication board (RFI) has five potential-free relay contacts for remote signaling of the following operating and fault indications: Unit on, Unit producing, Maintenance due, Error present, Furnace (not supported).</p> <p>The remote operating and fault indication board is installed in the control compartment of the RO-E(+) pure water system and connected to the driver board.</p>	X	X

3.7 Available accessories

Leakage monitoring	<p>The leakage monitoring option consist of the leakage monitoring control board and 1 floor sensor. The leakage monitoring control board is connected to driver board inside the Condair RO-E(+) pure water system and the sensor(s) are connected to the leakage monitoring control board. Important: the leakage monitoring does not override the direction that the Condair RO-E(+) pure water system must be installed in a room with a floor drain or in a tub equipped with a drain connected to the building drain system.</p>
Single water softener SoftCab DR25C EF	<p>The SoftCab DR25C EF single water softener is used to reduce the water hardness of the inlet water to 0-1 °dH (0-1.8 °fH, 0-18 ppm) if the inlet water exceeds certain specified values (see Section 5.4.9).</p> <p>Note: The SoftCab DR25C EF single water softener provides a regeneration contact that can be connected to the Condair RO-E(+) pure water system to stop the operation of the Condair RO-E(+) during the regeneration process.</p> <p>The SoftCab DR25C EF single water softener is delivered with a separate operating manual.</p>
Double water softener DSP25 EF	<p>The DSP25 EF double water softener is used to reduce the water hardness of the inlet water to 0-1 °dH (0-1.8 °fH, 0-18 ppm) if the inlet water exceeds certain specified values (see Section 5.4.9).</p> <p>The DSP25 EF double water softener is delivered with a separate operating manual.</p>
Double water softener S150 XP	<p>The S150 XP double water softener with mechanical hardness dial disk is used to reduce the water hardness of the inlet water to 0-1 °dH (0-1.8 °fH, 0-18 ppm) if the inlet water exceeds certain specified values (see Section 5.4.9).</p> <p>The S150 XP double water softener is delivered with a separate operating manual.</p>

Single filter	The 5 µm single filter serves as a pre-filter. The single filter can be installed before and/or after the water softener (if it is installed). Other types of single filters can also be used provided they meet at least the specification specified above.
Dual filter	The dual filter serves as pre-filter and must mandatory be installed if the supply water is occasionally chlorinated. The dual filter consist of an activated charcoal filter (1) and a 5 µm filter (2). Important: The dual filter is not intended to be used for filtration of permanently chlorinated water! The dual filter is to be installed before the water softener. Note: To extend the lifespan of the activated carbon filter, the dual filter can also be installed after the water softener, provided that the limit for free chlorine specified by the manufacturer is not exceeded. Note: Other types of dual filters may also be used provided they meet at least the specification specified above.
Triple filter	The triple filter serves as pre-filter and must mandatory be installed if the supply water is occasionally chlorinated. The triple filter consists of a 5 µm filter (1), an activated carbon filter (2) and a second 5 µm filter (3). Important: The triple filter is not intended to be used for filtration of permanently chlorinated water! The triple filter is to be installed before the water softener. Note: To extend the lifespan of the activated carbon filter, the triple filter can also be installed after the water softener, provided that the limit for free chlorine specified by the manufacturer is not exceeded. Note: Other types of triple filters may also be used provided they meet at least the specification specified above.
Pressure reducing valve	Pressure reducing valve for water inlet pressures >6 bar. The pressure reducing valve is to be installed in the supply water line after the shut-off valve.
Shut-off valve	Shut-off valve for installation in the supply water pipe to shut off the water supply.
Sampling tap	Sampling tap for installation in the supply water pipe for taking water samples.
Hose set	Hose set for connecting the Condair RO-E(+) pure water system and its accessories. Content: 1x armored hose G 3/4", length 1 m, straight fittings
Hose set 90°	Hose set for connecting the Condair RO-E(+) pure water system and its accessories. Content: 1x armored hose G 3/4", length 1 m, 2 x 90° fittings
External pressure tank for Condair RO-E+	External pressure tank for Condair RO-E+ pure water system with a nominal volume of 140 l (usable volume at 5 bar: 102 l). Note: For all unit sizes, up to three external pressure tanks including the internal pressure tank (for RO-E+ 40 and RO-E+ 100 models) can be connected in series.
External pressure tank for Condair RO-E	External pressure tank for Condair RO-E 200/300 pure water systems with a nominal volume of 102 l (usable volume at 5 bar: 79 l).

3.8 System overview

Principal system layout Condair RO-E(+) stand-alone systems

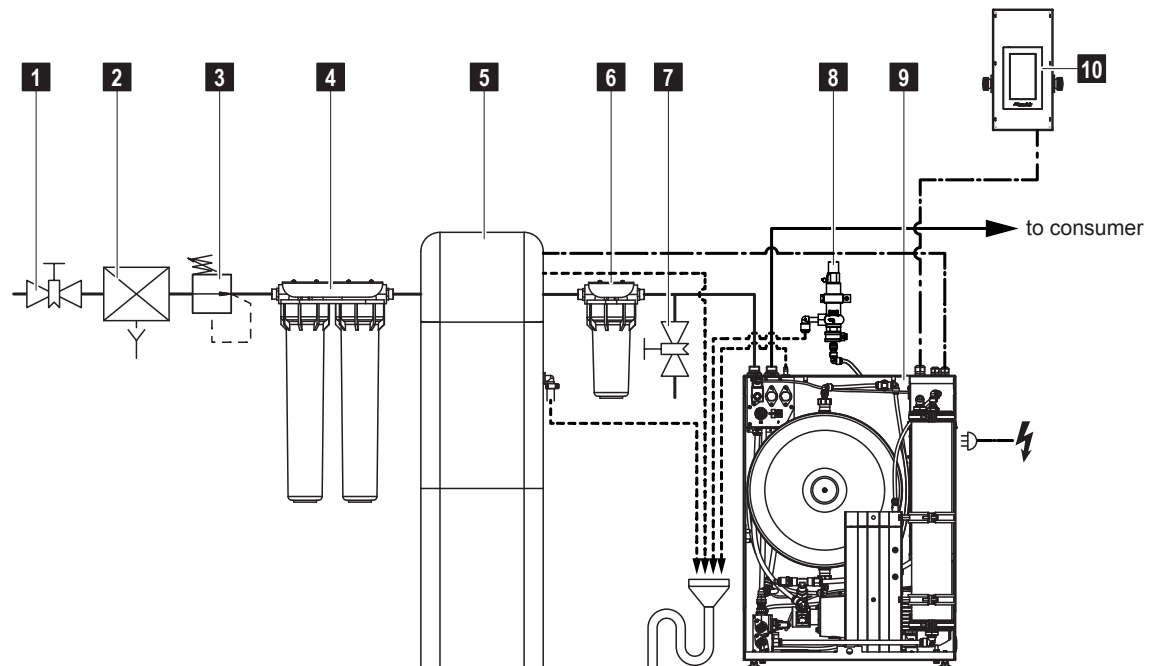

- | | |
|---|---|
| 1 Shut-off valve (mandatory, by others) | 6 Filter 5 µm (mandatory if water softener is used, available as accessory) |
| 2 Backflow preventer (where mandatory by local regulations, by others) | 7 Sampling tap (optional, recommended for taking water samples) |
| 3 Pressure reduction valve (mandatory for water supply pressure >6 bar, available as accessory) | 8 Safety valve pressure tank (optional, mandatory for CE certified systems) |
| 4 Single, double or triple pre-filter (optional but recommended, double or triple filter mandatory for occasionally chlorinated supply water, available as accessory) | 9 Condair RO-E(+) |
| 5 Water softener (optional, recommended if the supply water hardness exceeds the limits specified in Section 5.4.9 , available as accessory) | 10 External control unit |

Fig. 1: *Principal system layout Condair RO-E(+) stand-alone systems (figure shows RO-E 100 with internal pressure tank)*

Principal system layout Condair RO-E(+) integrated systems with Condair RS steam humidifier

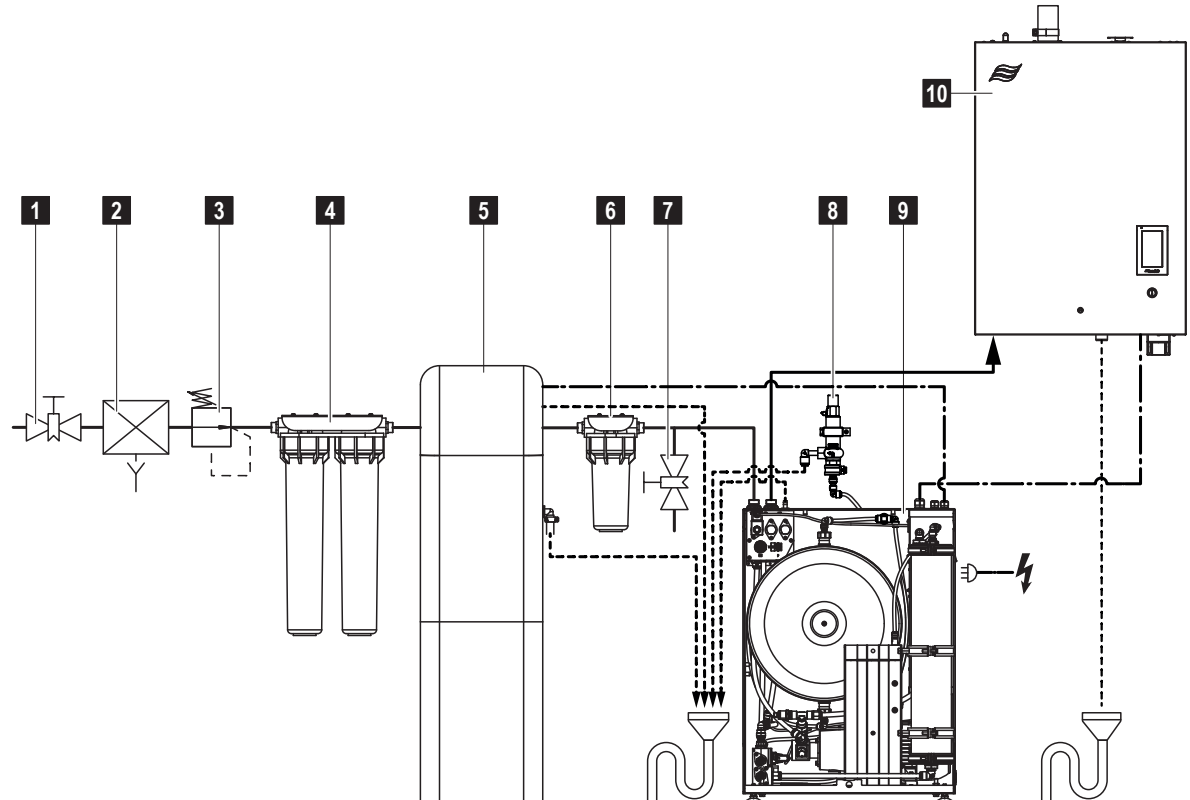

- | | | | |
|---|---|----|---|
| 1 | Shut-off valve (mandatory, by others) | 6 | Filter 5 µm (mandatory if water softener is used, available as accessory) |
| 2 | Backflow preventer (where mandatory by local regulations, by others) | 7 | Sampling tap (optional, recommended for taking water samples) |
| 3 | Pressure reduction valve (mandatory for water supply pressure >6 bar, available as accessory) | 8 | Safety valve pressure tank (optional, mandatory for CE certified systems) |
| 4 | Single, double or triple pre-filter (optional but recommended, double or triple filter mandatory for occasionally chlorinated supply water, available as accessory) | 9 | Condair RO-E(+) |
| 5 | Water softener (optional, recommended if the supply water hardness exceeds the limits specified in Section 5.4.9 , available as accessory) | 10 | Condair RS steam humidifier |

Fig. 2: Principal system layout Condair RO-E(+) integrated systems (figure shows RO-E 100 with internal pressure tank and Condair RS steam humidifier)

4 Important notes

4.1 Inspection of the delivery

After receiving:

- Inspect shipping boxes for damage.
Any damages of the shipping boxes must be reported to the shipping company without delay.
- Check packing slip to ensure all parts has been delivered.
All material shortages are to be reported to your Condair supplier within 48 hours after receipt of the goods. Condair assumes no responsibility for any material shortages beyond this period.
- Unpack the parts/components and check for any damage.
If parts/components are damaged, notify the shipping company immediately.
- Check whether the components are suitable for installation on your site according to the facility documentation.

4.2 Storage and Transportation

Storing

Until installation store the Condair RO-E(+) pure water system components in its original packaging in a protected area meeting the following requirements:

- Room temperature: 5 ... 40 °C
- Room humidity: 10 ... 75 %rh

Transportation

For optimum protection always transport the Condair RO-E(+) pure water system components in their original packaging and use appropriate lifting/transporting devices.



WARNING!

It is the customer's responsibility to ensure that installers and operators are trained in handling heavy goods and that the operators comply with the appropriate regulations on work safety and the prevention of accidents.

Packaging

In case you wish to dispose of the packaging, observe the local regulations on waste disposal. Please recycle packaging where possible.

5 Mounting and installation work

5.1 Safety notes on mounting and installation work

Qualification of personnel

All mounting and installation work must be carried out only by **properly instructed and well qualified personnel (e.g. certified plumbers and certified electricians) authorized by Condair**. It is the owner's responsibility to verify proper qualification of the personnel.

General notes

Strictly observe and comply with all information given in the present installation manual regarding the positioning and mounting of the Condair RO-E(+) pure water system components and the water and electrical installations.

Observe and comply with all local regulations dealing with water and electrical installations.

Safety

Some installation work requires removal of the unit covers. Please note the following:



DANGER!
Risk of electric shock!

The Condair RO-E(+) pure water system is mains powered. Live parts may be exposed when the control compartment or the terminal box of the pump motors/are open. Touching live parts may cause severe injury or danger to life.

Prevention: Before carrying out any work on the components of the Condair RO-E(+) pure water system make sure the system is disconnected from the mains and secured against inadvertent power-up.

Important: The frequency converter in the Condair RO-E(+) pure water system contains capacitors. These can remain charged with a potentially deadly voltage for a certain period of time after the Condair RO-E(+) pure water system has been disconnected from the power supply. Therefore, wait at least 10 minutes after disconnecting the power supply. Then make sure the appropriate contacts on the frequency converter and the terminals on the pump motor are free of voltage before starting any work on these components!



CAUTION!

The electronic components inside the control compartment of the Condair RO-E(+) pure water system, the external control unit and the control compartment/control unit of the corresponding Condair humidifier are sensitive to electrostatic discharge. Before carrying out installations work inside these units, appropriate measures must be taken to protect the electronic components against damage caused by electrostatic discharge (ESD protection).

5.2 Requirements on siting and installation

Typically, the siting of a Condair RO-E(+) pure water system is determined at the planning stage and set down in the facility documentation. The following general guidance on component siting should be observed in all cases, however:

- All installation work must be performed in accordance with industry good practice and the supply (fitting) regulations from local utilities.
- All Condair RO-E(+) pure water system components must be installed inside a building in a room which can be locked and which is accessible only to a limited number of people. The room must meet the following requirements:
 - The room temperature must be between +10 °C and +30 °C throughout the year.
 - The room must be equipped with a **floor drain with sufficient drain capacity (min. 1000 l/hr)**.
Note: If no floor drain is available all Condair RO-E(+) pure water system components must be installed in tub equipped with a drain connected to the building waste water line.
 - The room must be equipped with tap water supply capable to deliver the required water flow according to the table below.

System type	Minimum water flow rate at 1.5 bar flow pressure
Condair RO-E(+) 40	300 l/hr
Condair RO-E(+) 100	450 l/hr
Condair RO-E(+) 200	600 l/hr
Condair RO-E(+) 300	800 l/hr

- Depending on the device voltage (see rating plate on device) and the version of the Condair RO-E(+) pure water system, the room must be equipped either with:
 - a **230 VAC / 50-60 Hz (P, N and PE)** or a **110 VAC / 60 Hz (P, N and PE) mains wall socket** (devices with device cable) or
 - a **230 VAC / 50-60 Hz (P, N und PE)** or a **110 VAC / 60 Hz (P, N und PE) mains supply line with electrical isolator** (hardwired devices)

for the power supply of the Condair RO-E(+) pure water system.

The mains wall socket or the electrical isolator should be located in the immediate vicinity of the Condair RO-E(+) pure water system at a **height between 1.0 to 1.5 m above the floor**.

The mains wall socket or the mains supply line should be protected **with a residual current device (RCCB)** or a **UL listed Class A ground-fault circuit-interrupter (GFCI)**. The RCCB and GFCI must meet the following requirements:

	RCCB requirements	GFCI requirements
Type:	A (EN 61008)	UL listed Class A
Trip current:	0.03 A or less	0.05 A (defined by class A standard)
Pin count:	2	2
Protection class:	IP40	IP40
Fitted with test button		

The mains wall socket or the mains supply line must be protected with a "F1" 10 A slow acting fuse (230 VAC / 50-60 Hz) or 15 A slow acting fuse (110 VAC / 60 Hz).

- Depending whether and which type of water softener is used additional power supply wall sockets may be required in the room. Refer to the corresponding water softener manual regarding the power supply requirements.
- The room must be equipped with an **open funnel with trap** connected to the building waste water line with **sufficient drain capacity (min. 1,000 l/hr)**.
- The installation site should be chosen so that all system components are shielded from thermal and solar radiation.
- Ensure that structures (walls, stanchions, ceilings, etc.) to which the equipment/system components is/are to be mounted have a sufficient load-bearing capacity and are suitable for installing the devices.
- Install the Condair RO-E(+) pure water system components in such a manner that they are **freely accessible** with sufficient space available for operation and maintenance purposes.
- To avoid bacterial contamination, drain pipework of the Condair RO-E(+) pure water system must not come into contact with the drain water funnel (an air gap of at least 2 cm must be maintained).
- **No modifications must be undertaken** on the Condair RO-E(+) pure water system without the express written consent of Condair.
- The installation of any additional fittings (e.g. valves, etc.) not indicated on the installation schematic is prohibited within the entire Condair system.
- Comply with material specifications at all times.

Distances to be observed

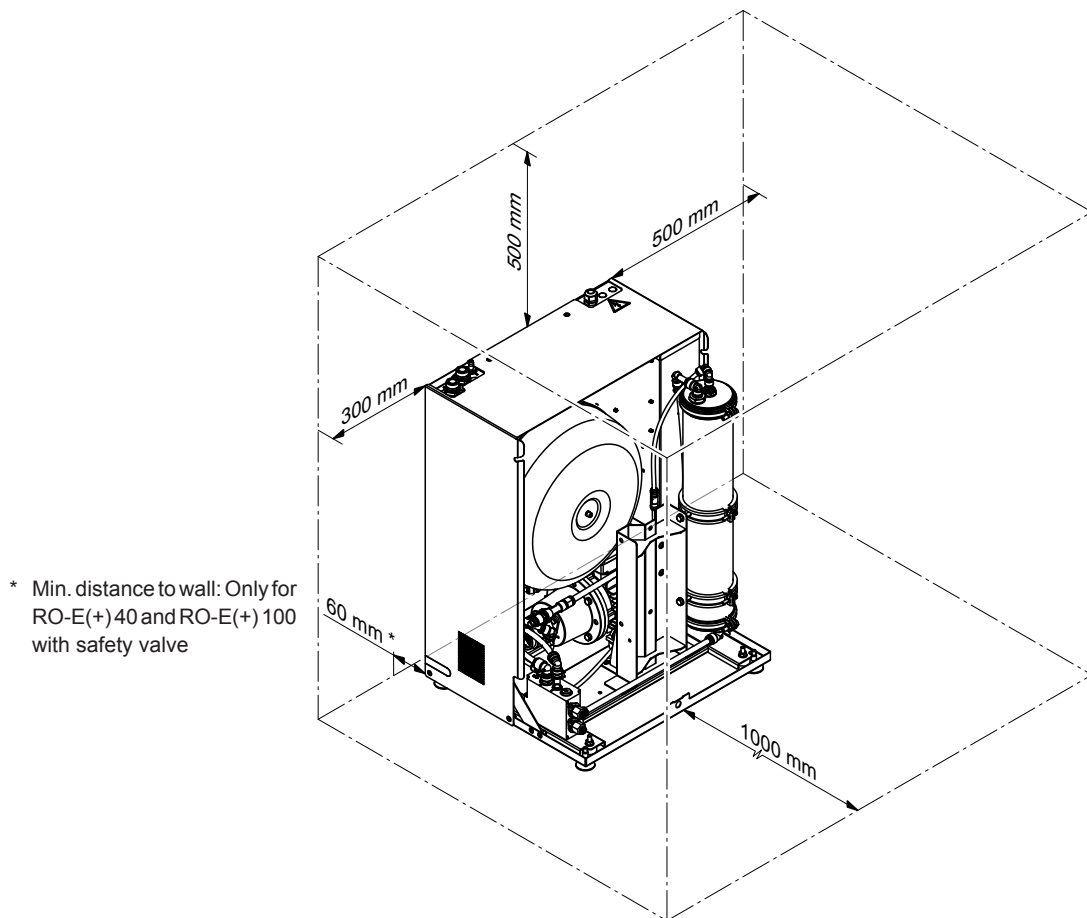

Fig. 3: Distances to be observed

5.3 Positioning the Condair RO-E(+) pure water system components

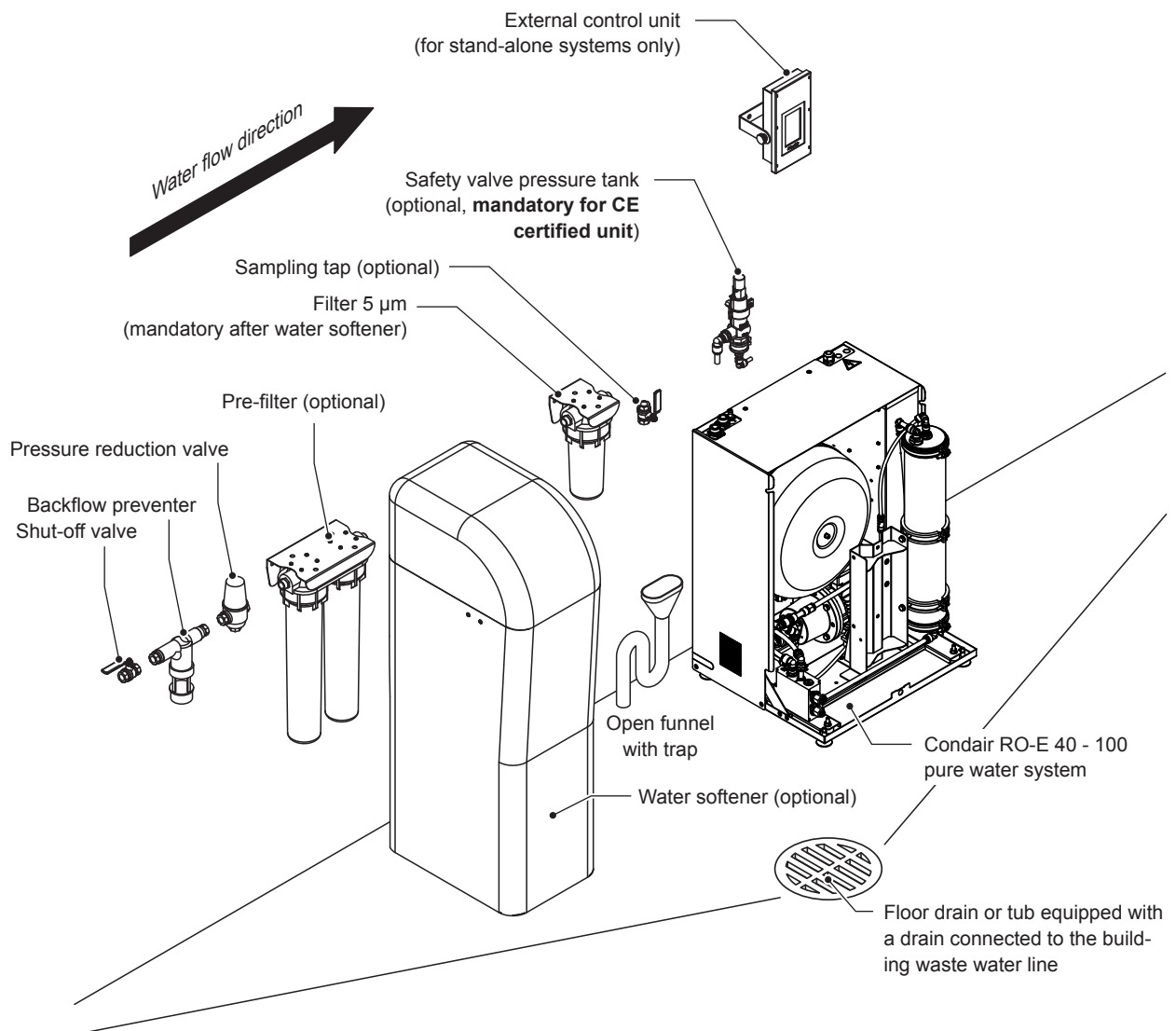

Fig. 4: Positioning of the system components for **Condair RO-E 40/100** pure water systems

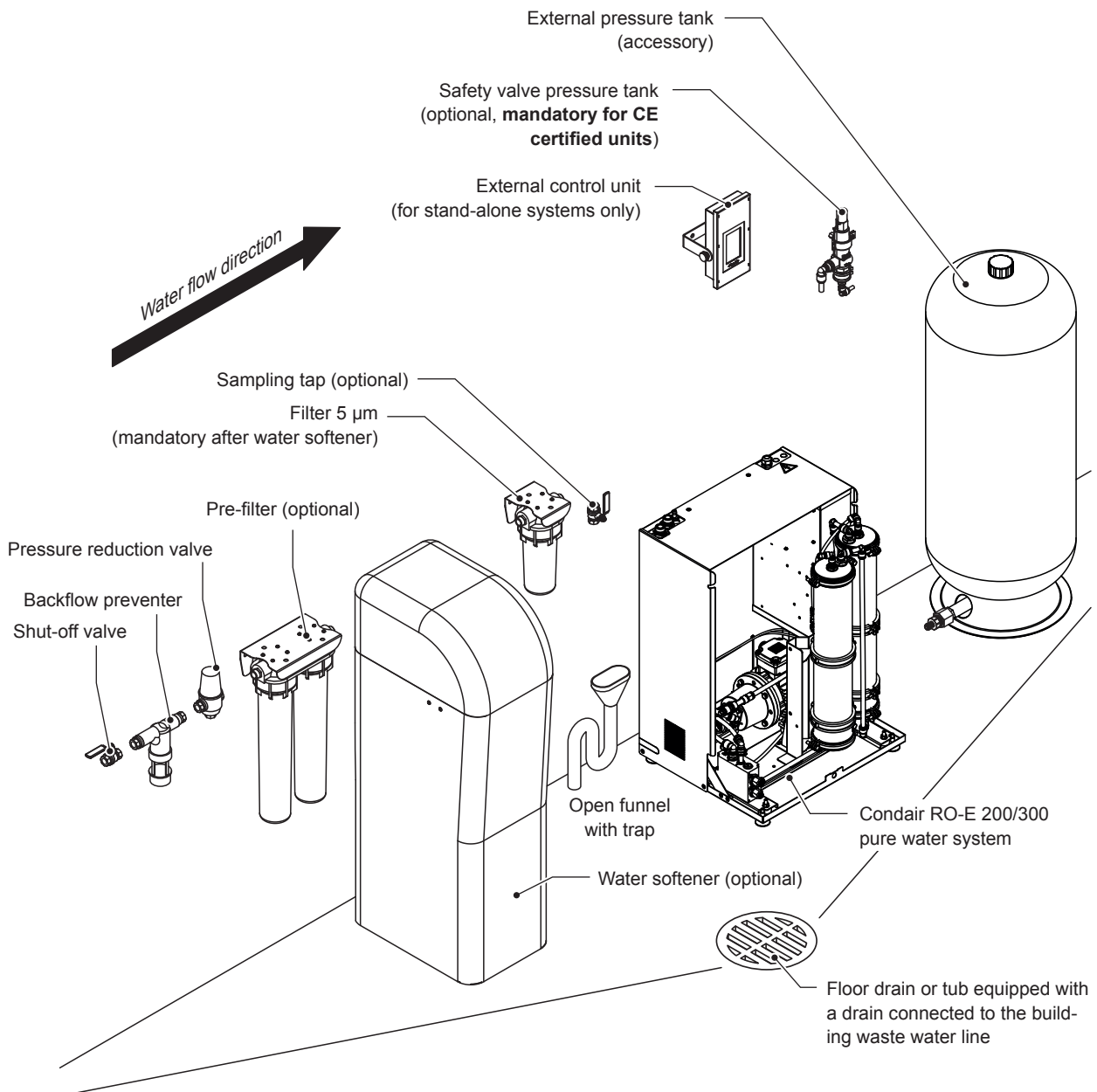

Fig. 5: Positioning of the system components for **Condair RO-E 200/300** pure water systems with external pressure tank

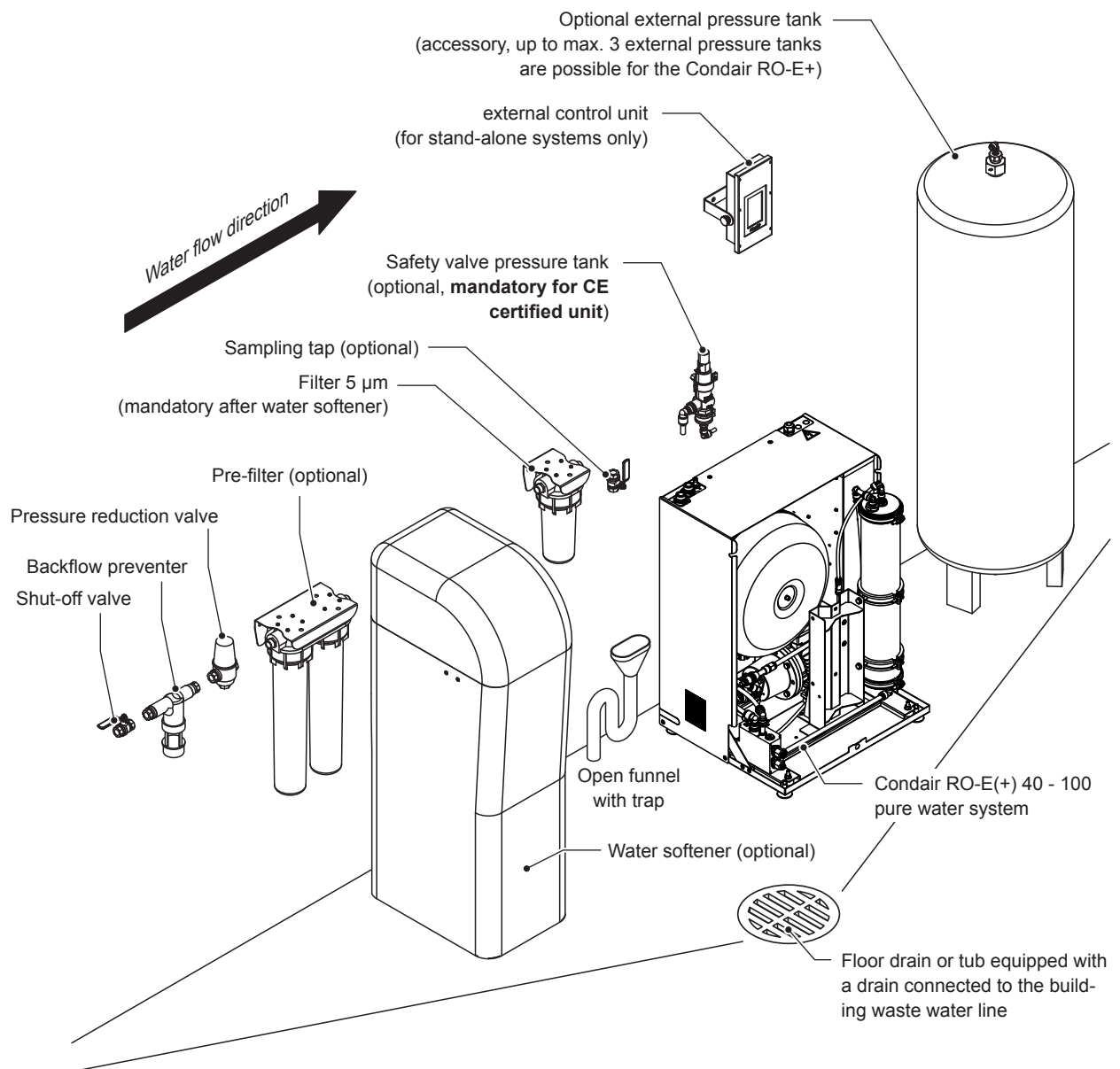

Fig. 6: Positioning of the system components for **Condair RO-E+ 40/100** pure water systems with or without optional external pressure tank

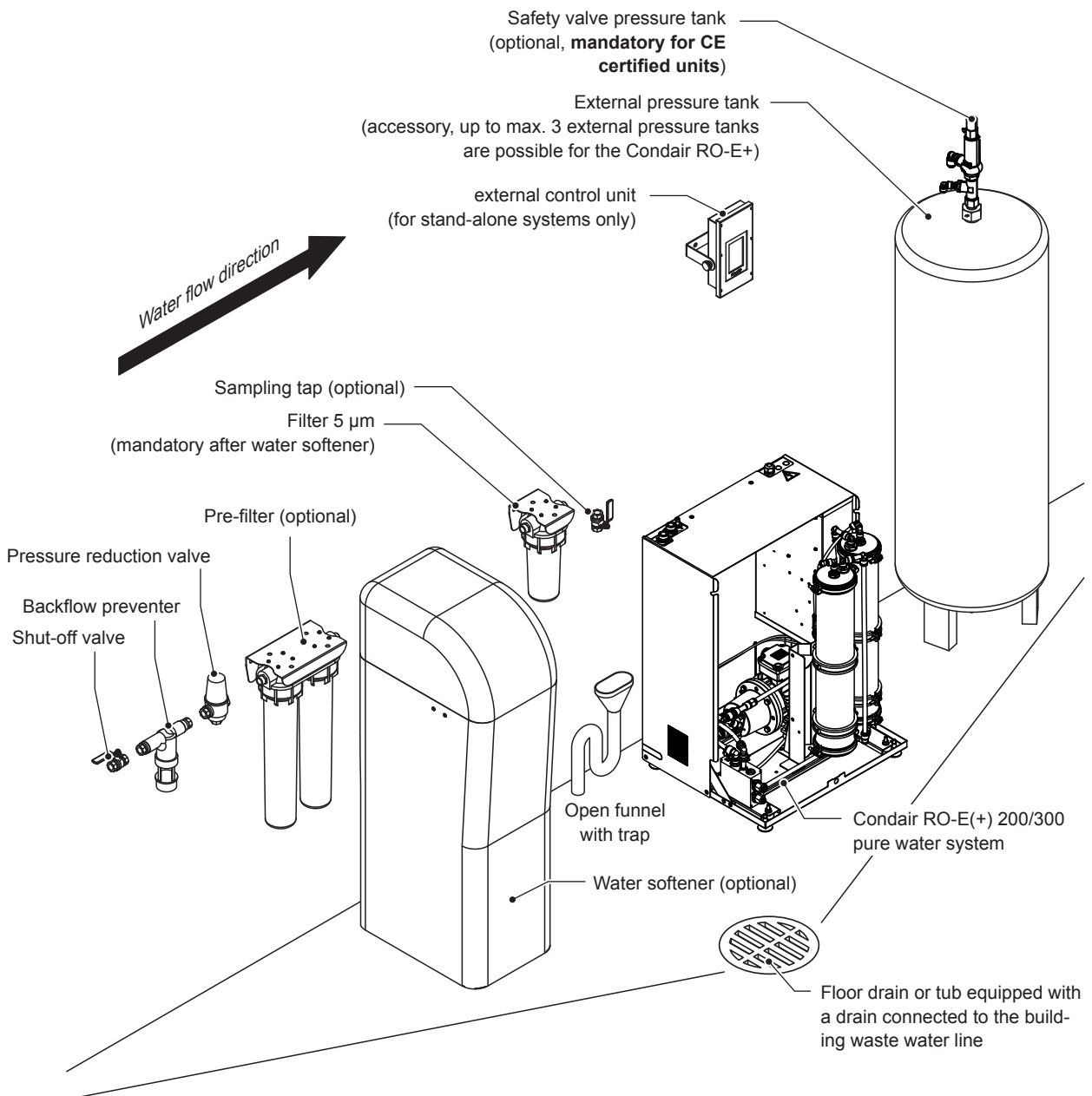

Fig. 7: Positioning of the system components for **Condair RO-E+ 200/300** pure water systems with external pressure tank

General positioning notes

- Whenever possible place/mount the system components on the same level and in the same room.
- Mount the external control unit at a suitable height for operation and near the Condair RO-E(+) pure water system.
- The components upstream of the Condair RO-E(+) pure water system (shut-off valve up to and including test cock) must be installed in the sequence shown in [Fig. 4](#) bis [Fig. 7](#).
- The external pressure tank(s) (up to max. 3 external pressure tanks possible) can be placed on the left or on the right side of the Condair RO-E(+) pure water system.
- Make sure the distances between the components are as short as possible.
Note: Please observe the maximum lengths of the supplied signal cables. These are 4 m between the Condair RO-E(+) and the external control unit/humidifier, and 5 m between the Condair RO-E(+) and the water softener.
- The pressure tank safety valve (optional, **mandatory for CE certified systems**) must be placed as follows:
 - for Condair RO-E 40/100 pure water systems with internal pressure tank:
mounted on the wall to the left of the center of the pure water system and approximately 150 mm above the unit, see [Fig. 4](#)
 - for Condair RO-E 200/300 with external pressure tank:
mounted on the wall approximately 150 mm above the external pressure tank, see [Fig. 5](#)
 - for Condair RO-E+ 40/100 pure water systems with internal pressure tank, with or without optional external pressure tank(s):
mounted on the wall to the left of the center of the pure water system and approximately 150 mm above the unit, see [Fig. 6](#)
 - for Condair RO-E+ 200/300 with external pressure tank(s):
Connected directly to the upper connection of the (first) pressure tank, see [Fig. 7](#)
- Make sure the drain line of the Condair RO-E(+) pure water system is as short as possible and the drain funnel is located below the drain connector of the Condair RO-E(+) pure water system.
- Make sure the reverse osmosis water line from the outlet of the Condair RO-E(+) pure water system to the connector of the consumer is as short as possible and the height difference is as low as possible. **The pressure drop of the reverse osmosis water line must not exceed 1 bar.**
- Make sure that the temperature of the reverse osmosis water in Condair RO-E+ pure water systems in conjunction with adiabatic humidifiers **does not exceed 20°C**.

The installer must ensure that the positioning and installation specifications are adhered to.

5.3.1 Mounting of the pre-filter

For installing the pre-filter, please follow the installation instructions in the separate instructions for the corresponding filter.

5.3.2 Positioning the optional water softener and the 5 µm filter (if applicable)

Place the water softener on the floor at the desired position and install the 5µm filter close to the water softener.

Information on the placement and connection of the water softener and the 5 µm filter can be found in the separate instructions for the respective water softener and the 5 µm filter.

5.3.3 Positioning the Condair RO-E(+) pure water system

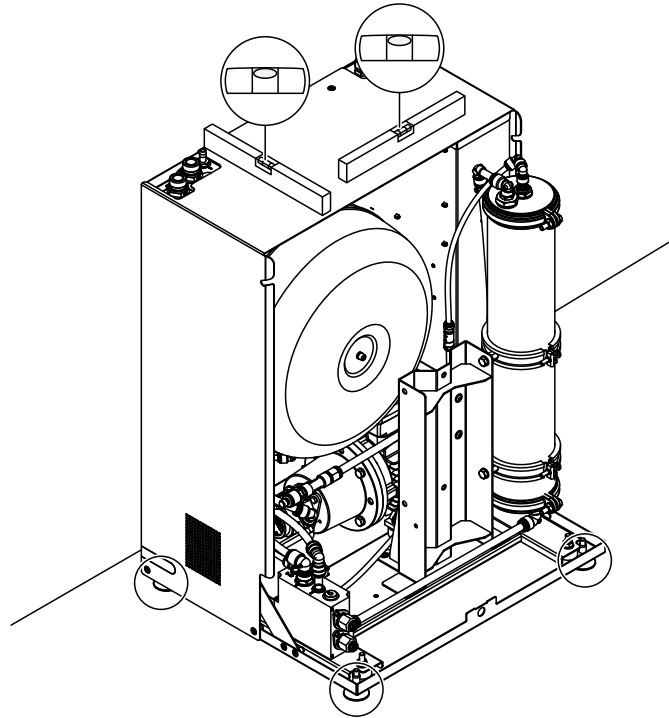



Fig. 8: Positioning the Condair RO-E(+) pure water system

Place the Condair RO-E(+) pure water system at the desired position and align unit with the four screw feet exactly horizontal using a level.

Important: For Condair RO-E(+) pure water systems with internal pressure tank, where the external pressure tank safety valve is used (e.g. CE certified systems), there must be a distance of at least 5 cm between a wall and the back of the unit in order that the pressure tank safety valve can be connected.

 **DANGER!**
Danger of electric hazard!

Do not connect Condair RO-E(+) pure water system to the mains yet.

5.3.4 Positioning the external pressure tank(s)

Place the external pressure tank(s) as near as possible to the Condair RO-E(+) pure water system on the floor. See [Fig. 23](#) to [Fig. 26](#) for maximum length of the tank connection hoses.

The pressure tank(s) can be positioned to the left or to the right of the Condair RO-E(+) pure water system. Secure the external pressure tank(s) against tilting with appropriate securing devices.

5.3.5 Mounting the external control unit (for stand alone systems only)

For installing the external control unit, please follow the installation instructions in the separate instructions for the control unit.

5.3.6 Mounting of the pressure tank safety valve for Condair RO-E(+) 40/100 and Condair RO-E 200/300

The pressure tank safety valve (e.g. for CE certified systems) must be mounted on site to the wall and connected to the Condair RO-E(+) pure water system using the black John Guest (JG) fittings and hoses supplied.

1. Connect all fittings and seals to the safety valve as shown in [Fig. 9](#).

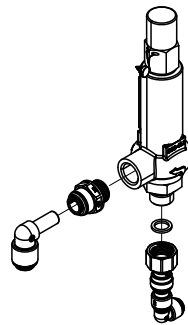

Fig. 9: Connect the screw fittings and seals to the pressure tank safety valve.

2. Mark fastening holes on the wall above the Condair RO-E(+) 40/100 pure water system or above the external tank for Condair RO-E 200/300 pure water systems.
3. Drill holes (Diameter: $\varnothing 10$ mm, Depth: 75 mm).
4. Insert the supplied dowels into the holes.
5. Mount the large pipe clamp on top and the small pipe clamp on the bottom to the wall and align the center of the clamps vertically.
6. Insert the safety valve with the water supply connection on the bottom into the pipe clamps and fasten the clamps with the screws.

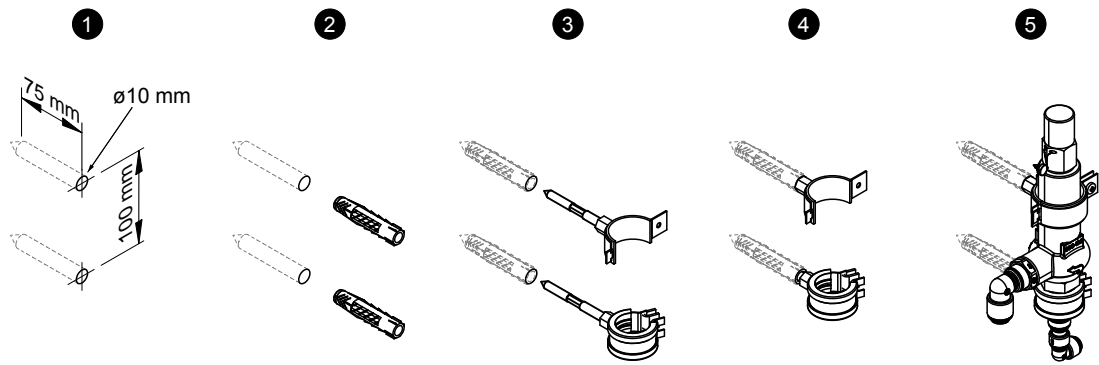

Fig. 10: Mounting the safety valve to the wall

5.3.7 Mounting of the pressure tank safety valve for RO-E+ 200/300

The pressure tank safety valve (e.g., in CE-certified systems) must be mounted on-site to the (first) pressure tank and connected to the Condair RO-E+ pure water system using the supplied black John Guest (JG) connectors and hoses.

1. Connect all fittings and seals to the safety valve as shown in [Fig. 11](#).

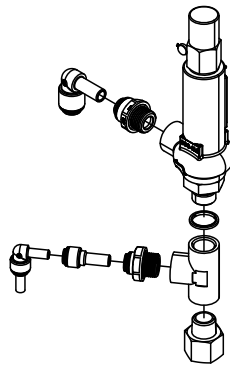

Fig. 11: Connect the screw fittings and seals to the pressure tank safety valve

2. Connect the safety valve to the upper port of the (first) pressure tank.

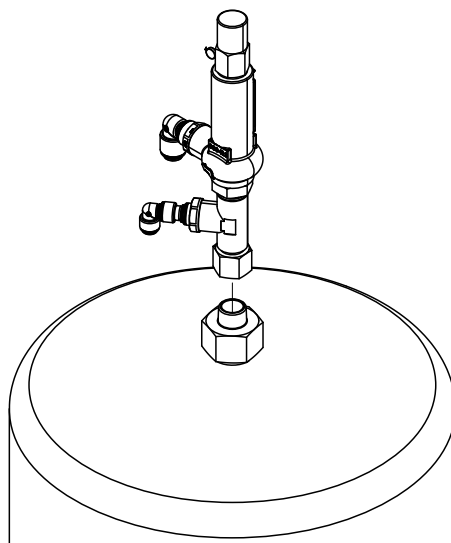

Fig. 12: Connecting the safety valve to the pressure tank

5.4 Water installation

5.4.1 Principal water installation for Condair RO-E 40/100 without pressure tank safety valve

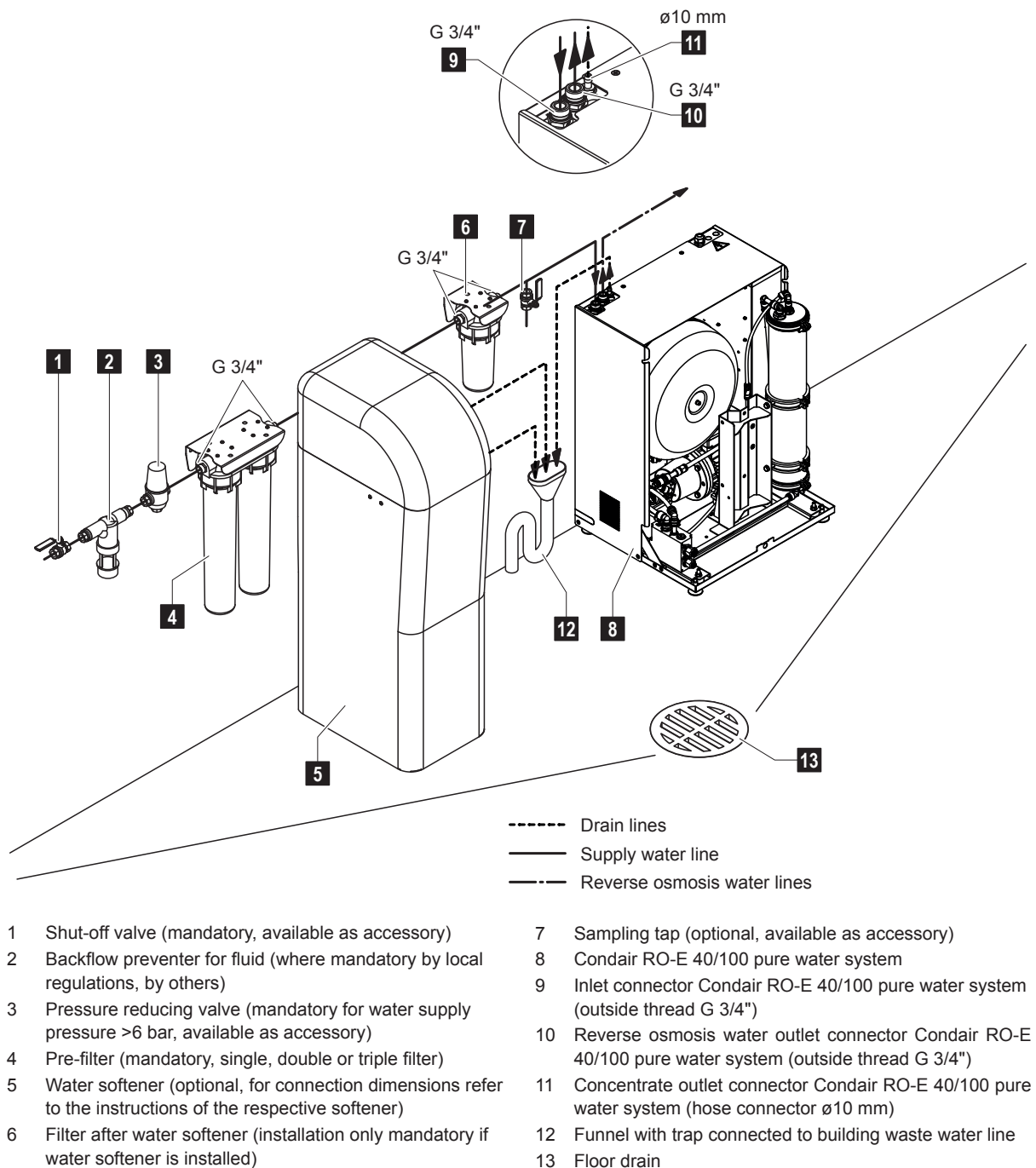
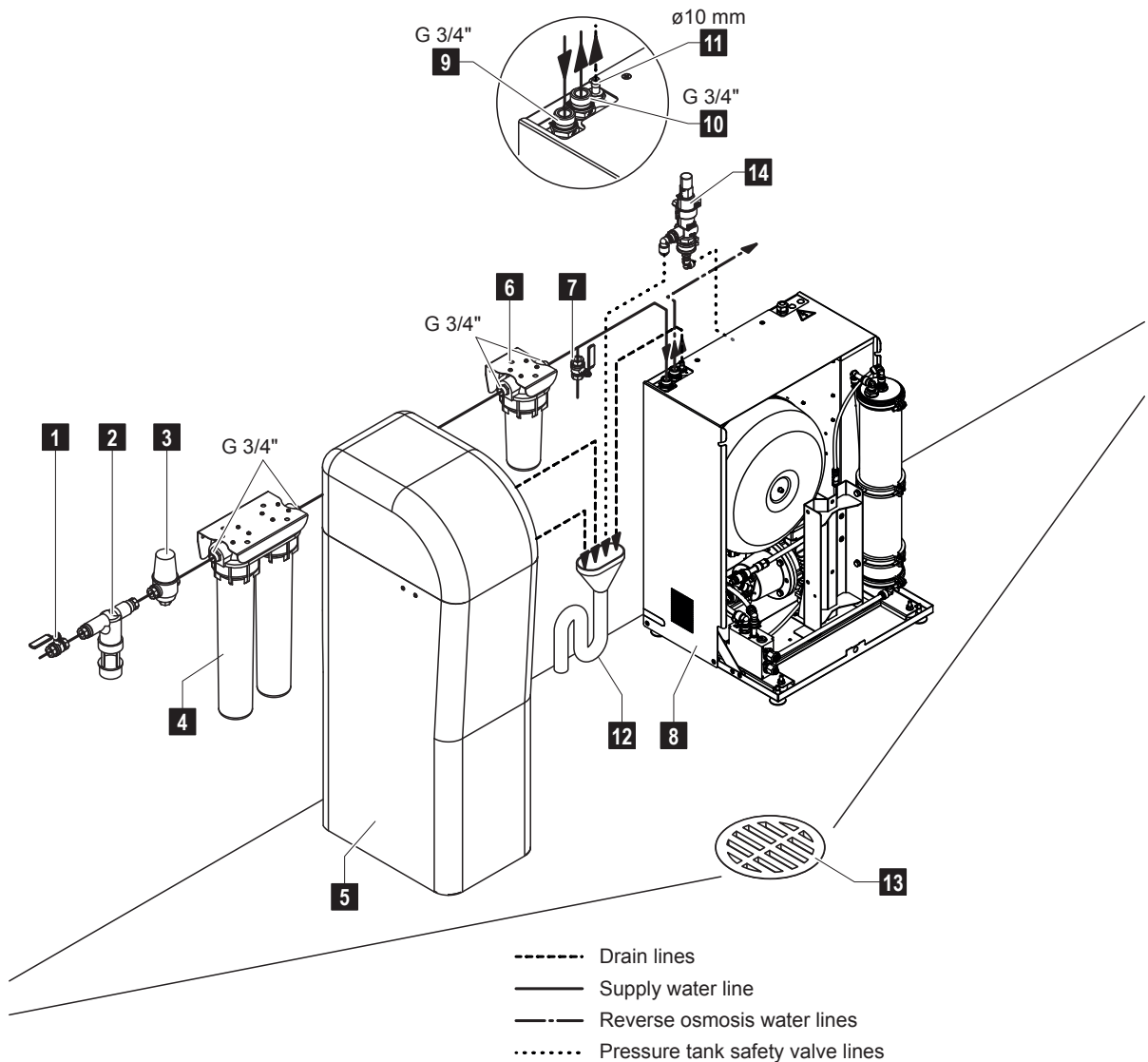

Fig. 13: Principal water installation for Condair RO-E 40/100 without pressure tank safety valve

5.4.2 Principal water installation for Condair RO-E 40/100 with pressure tank safety valve (e.g. CE certified systems)



- | | |
|---|--|
| 1 Shut-off valve (mandatory, available as accessory) | 8 Condair RO-E 40/100 pure water system |
| 2 Backflow preventer for fluid (where mandatory by local regulations, by others) | 9 Inlet connector Condair RO-E 40/100 pure water system (outside thread G 3/4") |
| 3 Pressure reducing valve (mandatory for water supply pressure >6 bar, available as accessory) | 10 Reverse osmosis water outlet connector Condair RO-E 40/100 pure water system (outside thread G 3/4") |
| 4 Pre-filter (mandatory, single, double or triple filter) | 11 Concentrate outlet connector Condair RO-E 40/100 pure water system (hose connector \varnothing 10 mm) |
| 5 Water softener (optional, for connection dimensions refer to the instructions of the respective softener) | 12 Funnel with trap connected to building waste water line |
| 6 Filter after water softener (installation only mandatory if water softener is installed) | 13 Floor drain |
| 7 Sampling tap (optional, available as accessory) | 14 Pressure tank safety valve |

Fig. 14: Principal water installation for Condair RO-E 40/100 mit Drucktank-Sicherheitsventil

5.4.3 Principal water installation for Condair RO-E 200/300 without pressure tank safety valve

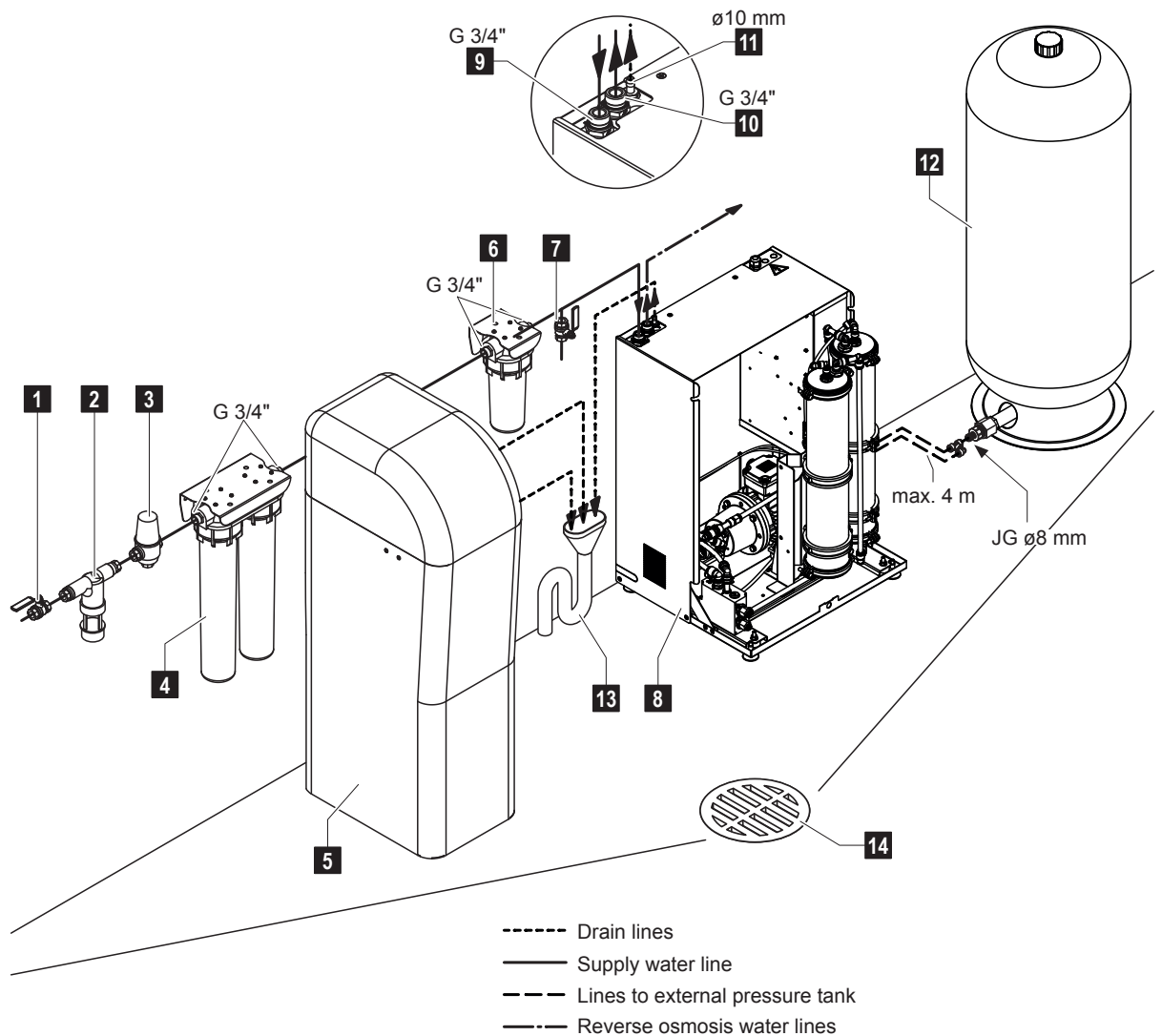

- | | |
|---|--|
| 1 Shut-off valve (mandatory, available as accessory) | 8 Condair RO-E 200/300 pure water system |
| 2 Backflow preventer for fluid (where mandatory by local regulations, by others) | 9 Inlet connector Condair RO-E 200/300 pure water system (outside thread G 3/4") |
| 3 Pressure reducing valve (mandatory for water supply pressure >6 bar, available as accessory) | 10 Reverse osmosis water outlet connector Condair RO-E 200/300 pure water system (outside thread G 3/4") |
| 4 Pre-filter (mandatory, single, double or triple filter) | 11 Concentrate outlet connector Condair RO-E 200/300 pure water system (hose connector ø10 mm) |
| 5 Water softener (optional, for connection dimensions refer to the instructions of the respective softener) | 12 External pressure tank 112 l (accessory) |
| 6 Filter after water softener (installation only mandatory if water softener is installed) | 13 Funnel with trap connected to building waste water line |
| 7 Sampling tap (optional, available as accessory) | 14 Floor drain |

Fig. 15: Principal water installation for Condair RO-E 200/300 without pressure tank safety valve

5.4.4 Principal water installation for Condair RO-E 200/300 with pressure tank safety valve (e.g. CE certified systems)

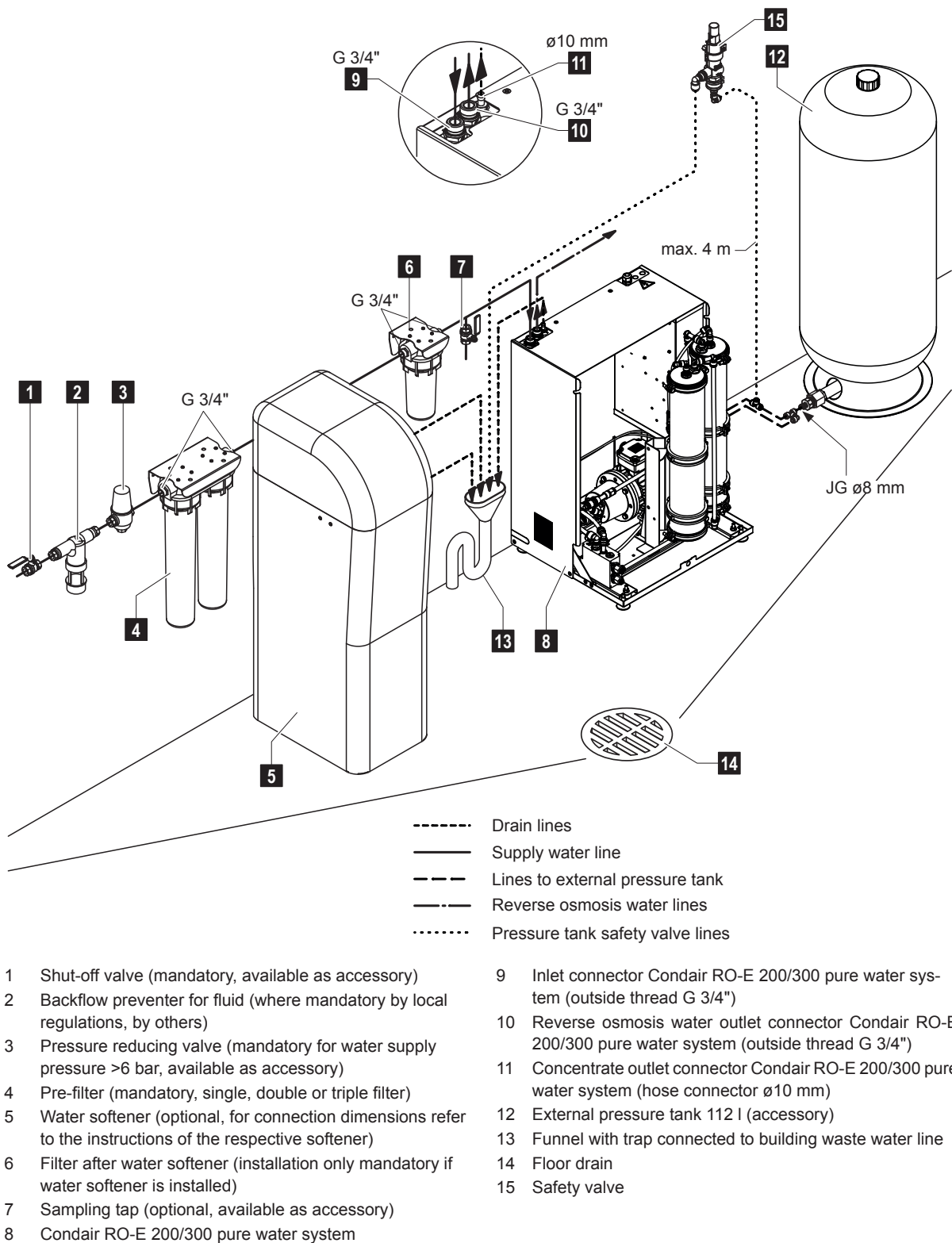
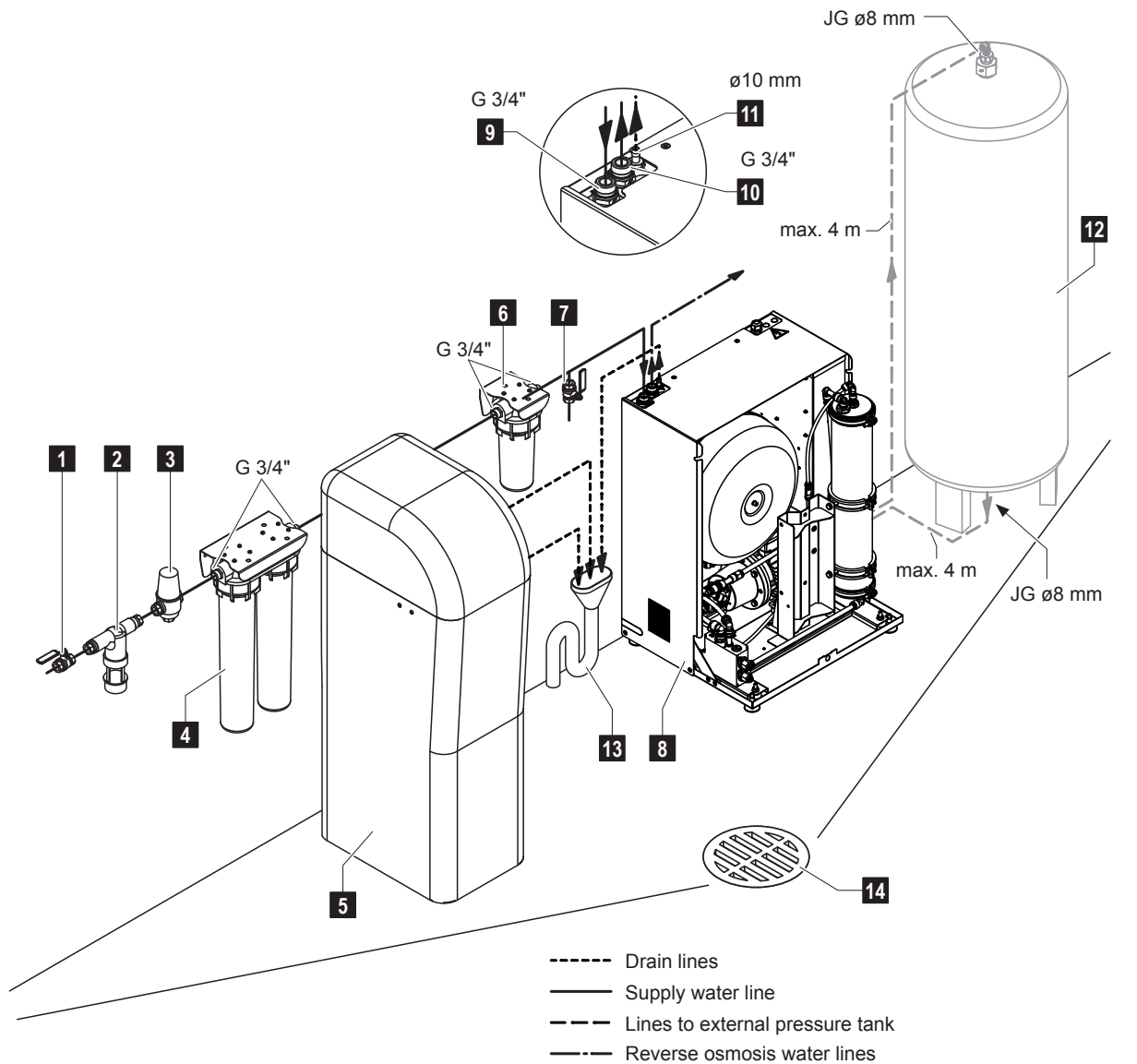

Fig. 16: Principal water installation for Condair RO-E 200/300 with pressure tank safety valve

5.4.5 Principal water installation for Condair RO-E+ 40/100 without pressure tank safety valve



- | | |
|---|--|
| 1 Shut-off valve (mandatory, available as accessory) | 9 Inlet connector Condair RO-E+ 40/100 pure water system (outside thread G 3/4") |
| 2 Backflow preventer for fluid (where mandatory by local regulations, by others) | 10 Reverse osmosis water outlet connector Condair RO-E+ 40/100 pure water system (outside thread G 3/4") |
| 3 Pressure reducing valve (mandatory for water supply pressure >6 bar, available as accessory) | 11 Concentrate outlet connector Condair RO-E+ 40/100 pure water system (hose connector \varnothing 10 mm) |
| 4 Pre-filter (mandatory, single, double or triple filter) | 12 Optional external pressure tank (accessory, only for Condair RO-E+, up to a max. of 3 external pressure tanks are possible) |
| 5 Water softener (optional, for connection dimensions refer to the instructions of the respective softener) | 13 Funnel with trap connected to building waste water line |
| 6 Filter after water softener (installation only mandatory if water softener is installed) | 14 Floor drain |
| 7 Sampling tap (optional, available as accessory) | |
| 8 Condair RO-E+ 40/100 pure water system | |

Fig. 17: Principal water installation for Condair RO-E+ 40/100 without pressure tank safety valve

5.4.6 Principal water installation for Condair RO-E+ 40/100 with pressure tank safety valve (e.g. CE certified systems)

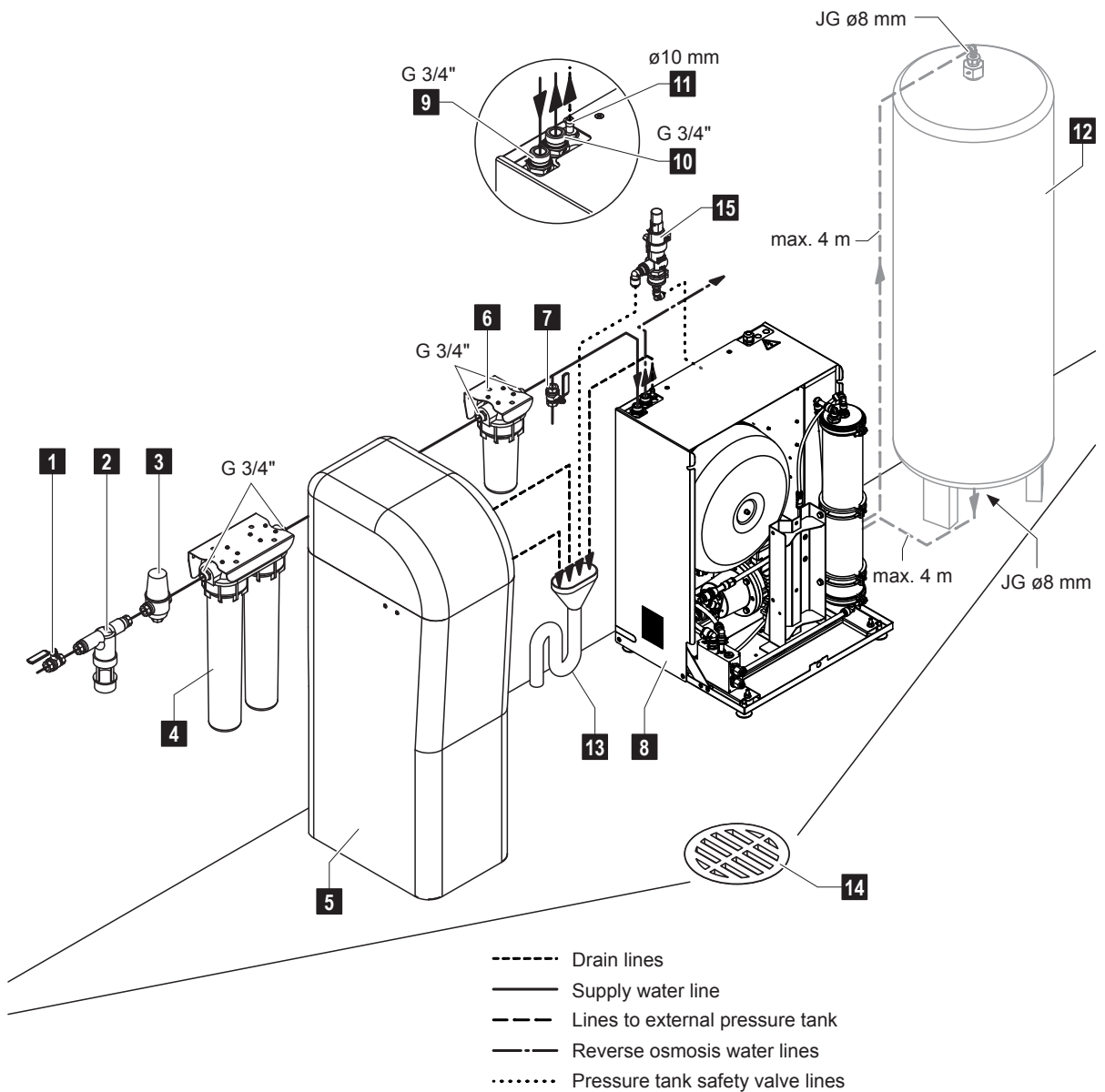

- | | |
|---|--|
| 1 Shut-off valve (mandatory, available as accessory) | 9 Inlet connector Condair RO-E+ 40/100 pure water system (outside thread G 3/4") |
| 2 Backflow preventer for fluid (where mandatory by local regulations, by others) | 10 Reverse osmosis water outlet connector Condair RO-E+ 40/100 pure water system (outside thread G 3/4") |
| 3 Pressure reducing valve (mandatory for water supply pressure >6 bar, available as accessory) | 11 Concentrate outlet connector Condair RO-E+ 40/100 pure water system (hose connector ø10 mm) |
| 4 Pre-filter (mandatory, single, double or triple filter) | 12 Optional external pressure tank (accessory, only for Condair RO-E+, up to a max. of 3 external pressure tanks are possible) |
| 5 Water softener (optional, for connection dimensions refer to the instructions of the respective softener) | 13 Funnel with trap connected to building waste water line |
| 6 Filter after water softener (installation only mandatory if water softener is installed) | 14 Floor drain |
| 7 Sampling tap (optional, available as accessory) | 15 Safety valve |
| 8 Condair RO-E+ 40/100 pure water system | |

Fig. 18: Principal water installation for Condair RO-E+ 40/100 with pressure tank safety valve

5.4.7 Principal water installation for Condair RO-E+ 200/300 without pressure tank safety valve

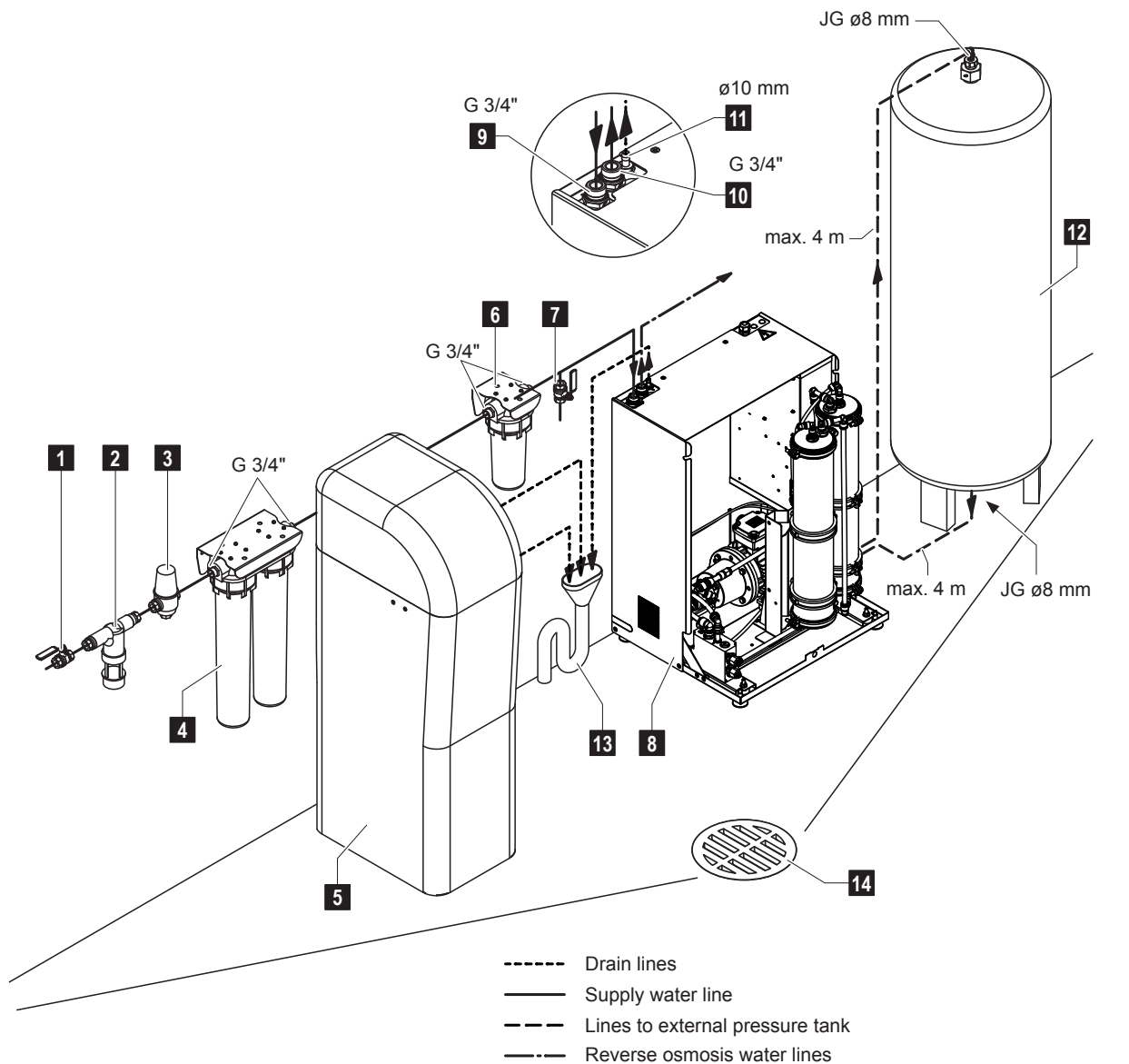

- | | |
|---|---|
| 1 Shut-off valve (mandatory, available as accessory) | 8 Condair RO-E+ 200/300 pure water system |
| 2 Backflow preventer for fluid (where mandatory by local regulations, by others) | 9 Inlet connector Condair RO-E+ 200/300 pure water system (outside thread G 3/4") |
| 3 Pressure reducing valve (mandatory for water supply pressure >6 bar, available as accessory) | 10 Reverse osmosis water outlet connector Condair RO-E+ 200/300 pure water system (outside thread G 3/4") |
| 4 Pre-filter (mandatory, single, double or triple filter) | 11 Concentrate outlet connector Condair RO-E+ 200/300 pure water system (hose connector $\varnothing 10$ mm) |
| 5 Water softener (optional, for connection dimensions refer to the instructions of the respective softener) | 12 External pressure tank (accessory, only for Condair RO-E+, up to a max. of 3 external pressure tanks are possible) |
| 6 Filter after water softener (installation only mandatory if water softener is installed) | 13 Funnel with trap connected to building waste water line |
| 7 Sampling tap (optional, available as accessory) | 14 Floor drain |

Fig. 19: Principal water installation for Condair RO-E+ 200/300 without pressure tank safety valve

5.4.8 Principal water installation for Condair RO-E+ 200/300 with pressure tank safety valve (e.g. CE certified systems)

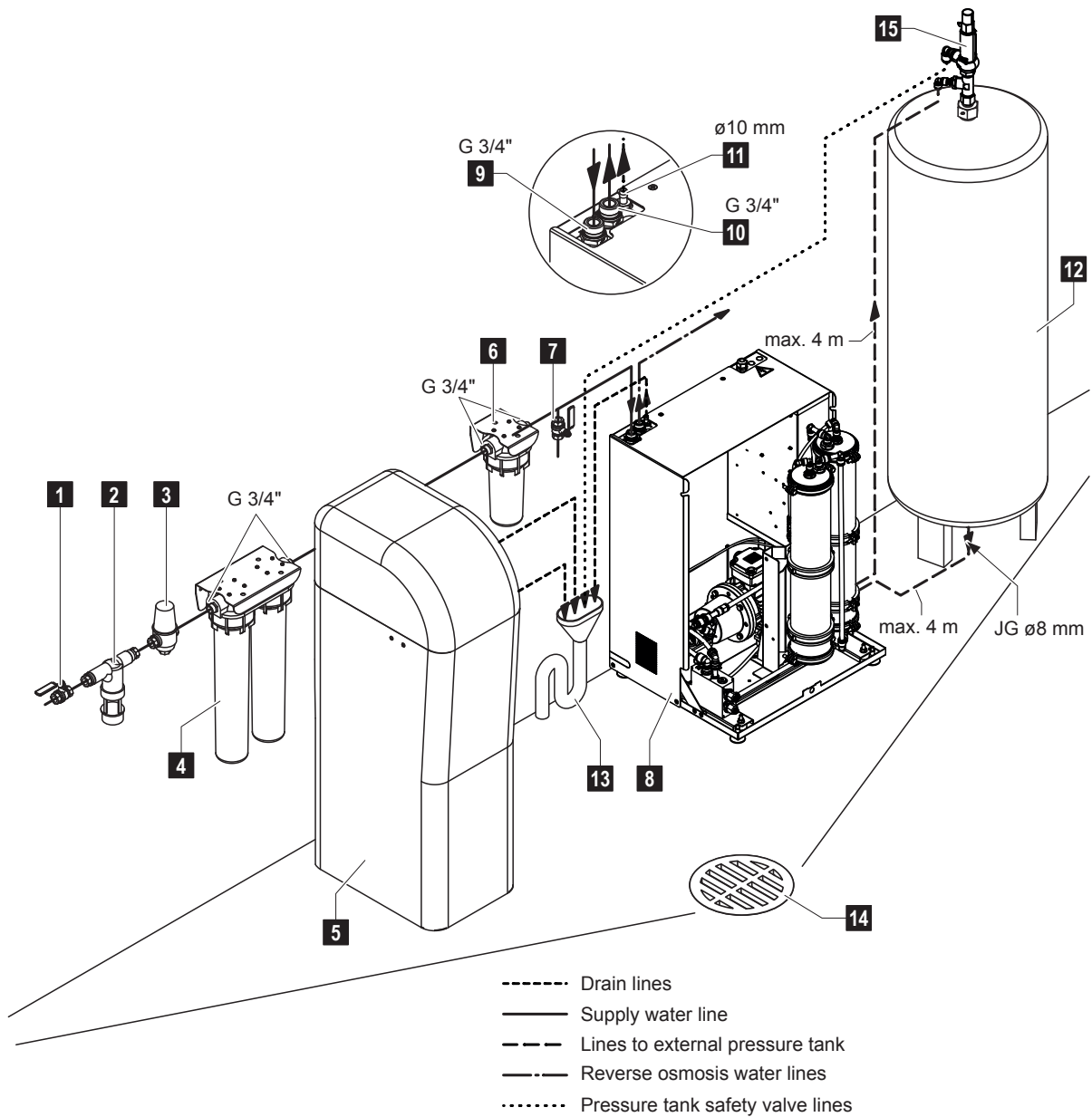

- | | |
|---|---|
| 1 Shut-off valve (mandatory, available as accessory) | 9 Inlet connector Condair RO-E+ 200/300 pure water system (outside thread G 3/4") |
| 2 Backflow preventer for fluid (where mandatory by local regulations, by others) | 10 Reverse osmosis water outlet connector Condair RO-E+ 200/300 pure water system (outside thread G 3/4") |
| 3 Pressure reducing valve (mandatory for water supply pressure >6 bar, available as accessory) | 11 Concentrate outlet connector Condair RO-E+ 200/300 pure water system (hose connector $\varnothing 10$ mm) |
| 4 Pre-filter (mandatory, single, double or triple filter) | 12 External pressure tank (accessory, only for Condair RO-E+, up to a max. of 3 external pressure tanks are possible) |
| 5 Water softener (optional, for connection dimensions refer to the instructions of the respective softener) | 13 Funnel with trap connected to building waste water line |
| 6 Filter after water softener (installation only mandatory if water softener is installed) | 14 Floor drain |
| 7 Sampling tap (optional, available as accessory) | 15 Safety valve |
| 8 Condair RO-E+ 200/300 pure water system | |

Fig. 20: Principal water installation for Condair RO-E+ 200/300 with pressure tank safety valve

5.4.9 Supply water requirements for the Condair RO-E(+) pure water system

The supply water must meet the following requirements:

Water supply quality	Drinking water quality
Water supply pressure	1.6 - 6 bar ¹⁾ Note: For higher supply water pressures, a pressure reducing valve set to 5 bar must be installed in the supply water line
Max. water temperature	20°C
Max. pH level without softener	8 (see also table below)
Free chlorine	up to 0.1 mg/l
Silt index (SDI)	max. 3
KMnO ₄	max. 10 mg/l
Fe	max. 0.2 mg/l
Mn	max. 0.05 mg/l
NTU	max. 1.0
SiO ₂	max. 1 mg/l

- ¹⁾ If filters/water softeners are installed upstream of the Condair RO-E(+) pure water system, the minimum pressure before these components must be 1 bar higher than the specified minimum pressure.

Common preconditions for the use of a water softener on the Condair RO-E			
pH level of incoming water	6.5 - 7.0	>7.0 - 7.5	>7.5 - 8.0
Max. water hardness	20 °dH ²⁾ (350 ppm)	17 °dH ²⁾ (300 ppm)	10 °dH ²⁾ (180 ppm)
Max. conductivity	1300 µS/cm ²⁾	750 µS/cm ²⁾	400 µS/cm ²⁾
Max. TDS	800 mg/l ²⁾	500 mg/l ²⁾	250 mg/l ²⁾

- ²⁾ If any of these values of the incoming water are higher at related pH value, a water softener should be installed before the Condair RO-E pure water system.

Common preconditions for the use of a water softener on the Condair RO-E+			
pH level of incoming water	6.5 - 7.0	>7.0 - 7.5	>7.5 - 8.0
Max. water hardness	20 °dH ³⁾ (350 ppm)	17 °dH ³⁾ (300 ppm)	10 °dH ³⁾ (180 ppm)
Max. conductivity	650 µS/cm ³⁾	650 µS/cm ³⁾	400 µS/cm ³⁾
Max. TDS	800 mg/l ³⁾	500 mg/l ³⁾	250 mg/l ³⁾

- ³⁾ If any of these values of the incoming water are higher at related pH value, a water softener should be installed before the Condair RO-E+ pure water system.

5.4.10 Material specifications water installation



WARNING!

The material specifications provided below must be complied with at all times. They form an integral part of the product warranty. **Always** use the installation materials supplied by Condair.

Material for **raw water** supply lines:

Designation:	According local regulations
Specifications:	According local regulations
Connection:	3/4" outside thread
Operating pressure	10 bar
Operating temperature:	6 - 40 °C
Medium:	Raw water

Material for **RO water** pipework and fittings:

Designation:	Hose or piping: PP, aisi 304/316, POM, PVC, PA, PTFE
Specifications:	Food grade, impermeable to UV, inner diameter min. 13 mm
Connection:	3/4" outside thread
Operating pressure	10 bar
Operating temperature:	6 - 40 °C
Medium:	Pure water
Adhesive:	TANGIT

The corresponding ISO standards/DIN 8063 must be complied with regarding tolerances and dimensions.

5.4.11 Important notes on water installation

- All plumbing work may only be carried out by a **Condair service technician** or **qualified personnel authorized by the owner** (e.g., a plumber with appropriate training). It is the owner's responsibility to verify proper qualification of the personnel.
- Plumbing installations must be carried out in accordance with the information in these installation manual and the applicable local regulations for plumbing installations.
- All hoses must be laid in such a way that:
 - they do not become a tripping hazard
 - they have no kinks
 - they do not obstruct the operation and maintenance of the Condair RO-E(+) pure water system.
- All hoses must be secured or protected with suitable means to prevent them from chafing at edges during operation and from being accidentally torn off or damaged.
- All John Guest (JG) hoses must be cut straight and free of kinks using a suitable cutting tool. Burrs and sharp edges at the cut point must be removed to prevent damage to the JG couplings.

5.4.12 Notes on supply water line

The supply water line to the Condair RO-E(+) pure water system must be carried out according to one of the overview diagrams (see [Fig. 17](#) to [Fig. 20](#)). Please note the following information:

- **Important: The supply water line must mandatory be connected to the Condair RO-E(+) pure water system using a flexible hose.** Connection via a rigid pipe is not permitted.
- The installation material must correspond to the specifications in accordance with the information in [Section 5.4.10](#).
- It is mandatory to install a shut-off valve and a pre-filter in the water supply line upstream of the Condair RO-E(+) pure water system.
- If required by local regulations, a backflow preventer for fluid must be installed in the water supply line upstream of the Condair RO-E(+) pure water system.
- For connection pressures >6 bar, a pressure reducing valve (set to 6 bar) must be installed in the water supply line upstream of the Condair RO-E(+) pure water system.
- For connecting the pre-filter, the water softener and the 5 µm filter to the water supply line, please follow the instructions in the separate instructions for the corresponding water softener and filter.
- The optional sampling tap for checking the supply water quality must be installed in the water supply line immediately before the Condair RO-E(+) pure water system.

5.4.13 Notes reverse osmosis water line

The reverse osmosis water line must be routed from the outlet on the Condair RO-E(+) pure water system to the connection to the consumer according to the overview diagrams (see [Fig. 17](#) to [Fig. 20](#)). It must be ensured that the distance is as short as possible and the height difference to the consumer is as small as possible. The maximum permissible pressure loss of the reverse osmosis water pipe is 1 bar.

Important: The reverse osmosis water line must mandatory be connected to the Condair RO-E(+) pure water system using a flexible hose. Connection via a rigid pipe is not permitted.

The connection material for the reverse osmosis water line must correspond to the specifications in [Section 5.4.10](#).

5.4.14 Notes on drain lines

Drain line water softener

The drain line of the water softener must be connected to the drain connection of the water softener according to the overview diagrams (see [Fig. 17](#) to [Fig. 20](#)) (for connection dimensions, see instructions for the corresponding water softener) and guided at a constant downslope to the open drain funnel with trap in the room (max. length of the drain line: 5 m) Before the funnel the drain line must be fixed in such a way, that the end of the drain line does not touch the funnel (min air gap 2 cm) and can not slip out of the funnel. The funnel must be positioned below the drain connector of the water softener.

Drain line of the Condair RO-E(+) pure water system

The drain line of the Condair RO-E(+) pure water system (inner diameter 10 mm) must be connected to the drain connection (hose connection with an outside diameter of 10 mm) according to the overview diagrams (see [Fig. 17](#) to [Fig. 20](#)) and guided down to the funnel with trap in the room (max. length of drain line 5 m). Just before the funnel the drain line must be fixed in such a way, that the end of the drain line does not touch the funnel (min air gap 2 cm) and can not slip out of the funnel. The funnel must be positioned below the drain connector of the drain connector of the Condair RO-E(+) pure water system.

5.4.15 Connection of the external pressure tank(s) to the Condair RO-E(+) pure water system

The external pressure tank must be connected to the Condair RO-E(+) pure water system on site using the black JG hoses $\varnothing 8$ mm supplied.

Important:

- The length of the connecting hoses should be kept as short as possible. The maximum hose lengths shown in [Fig. 23](#) to [Fig. 26](#) must not be exceeded.
- Make sure that the connecting hoses are not routed higher than the "P. in" connection inside the Condair RO-E 200/300 pure water system (see [Fig. 23](#)) or higher than the connection at the top of the external pressure tank of the Condair RO-E(+) pure water systems (see [Fig. 24](#) to [Fig. 26](#)).
- The instructions regarding hose routing and hose fastening in [Section 5.4.11](#) must be strictly observed and followed.

1. Loosen the six screws securing the Condair RO-E(+) unit cover and remove the cover.
2. Break out the pre-cut hose passage on the desired side of the Condair RO-E(+) unit cover. Attach the edge protector as shown in [Fig. 21](#) and press it completely into the curve.

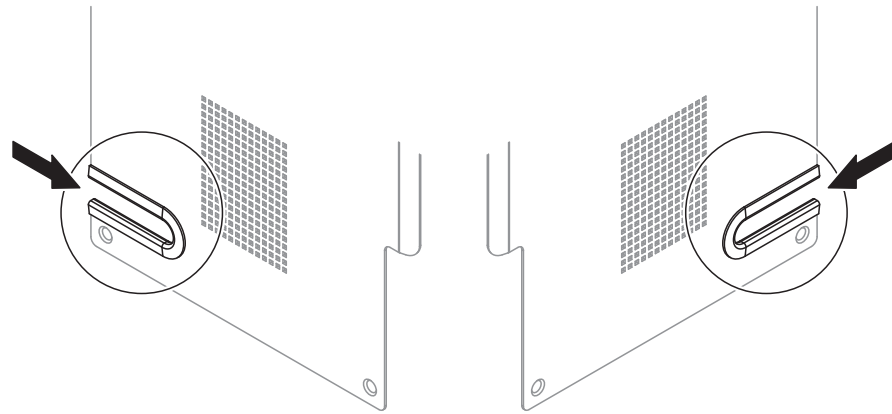

Fig. 21: Hose passage with mounted edge protection left/right

3. **On Condair RO-E+ 40/100:** Remove hose from "P. out" connection on the internal pressure tank to "P. in" connection of the inlet valve block.
4. **On Condair RO-E 200/300:** Connect the supplied black JG hose $\varnothing 8$ mm to the angle connector of the "P. out" port on the logic block (see [Fig. 23](#)). Route the hose to one of the ports on the Y-adapter on the external pressure tank. Cut the hose to length and connect it to the pressure tank's Y-adapter.

On Condair RO-E+ 40-300: Connect the supplied black JG hose $\varnothing 8$ mm to the angle connector of the internal pressure tank (see [Fig. 24](#)) or of the "P. out" connection of the logic block (see [Fig. 25](#)). Lead the hose to the **upper** connection on the (first) external pressure tank, cut the hose to length and connect it to the angle connector of the pressure tank.

- On Condair RO-E 200/300:** Connect the supplied black JG hose $\varnothing 8$ mm to the angle connector of the "P. in" port on the inlet valve block (see [Fig. 23](#)). Route the hose to the second, unused port of the Y-adapter on the external pressure tank. Cut the hose to length and connect it to the Y-adapter.

On Condair RO-E+ 40-300: Connect JG hose $\varnothing 8$ mm to the angle connector of the "P. in" connection of the inlet valve block (see [Fig. 24](#) or [Fig. 25](#)). Lead the hose to the **lower** connection on the (last) external pressure tank, cut the hose to length and connect it to the angle connector of the pressure tank.
- Secure both hoses to the cable tie holder at the bottom of the device using a cable tie.

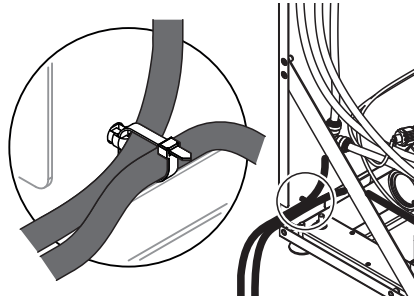

Fig. 22: Securing the hoses

- Attach the cover of the Condair RO-E(+) pure water system. Make sure that the two hoses to the pressure tank are routed properly through the broken-out hose passage. Fix the cover with the six screws.

Connecting the external pressure tank to the Condair RO-E 200/300 pure water system

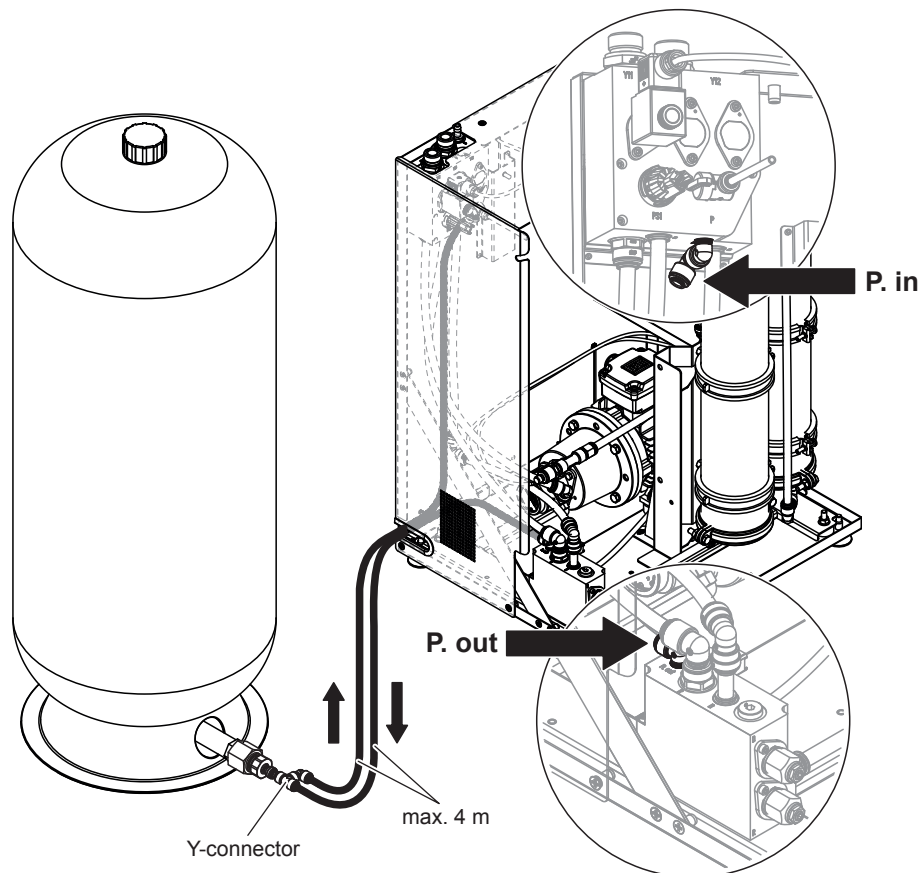

Fig. 23: Connecting the external pressure tank to the Condair RO-E 200/300 pure water system (figure shows RO-E 200)

Connecting the optional external pressure tank to the Condair RO-E+ 40/100 pure water system

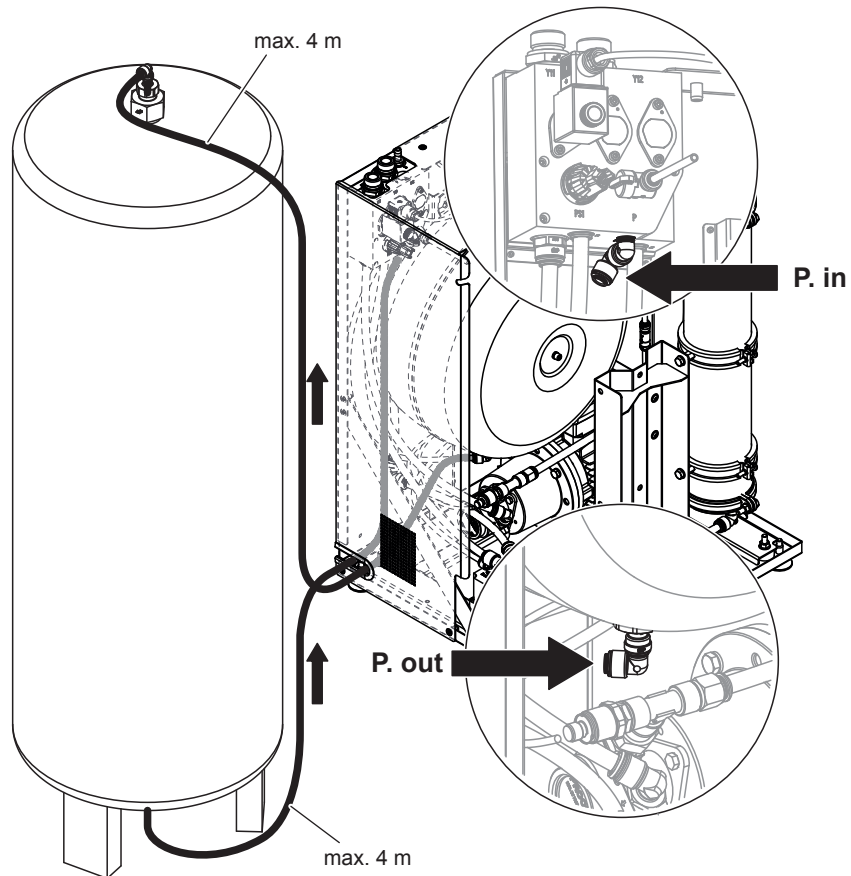

Fig. 24: Connecting the optional external pressure tank to the Condair RO-E+ 40/100 pure water system with internal pressure tank (figure shows RO-E+ 100)

Connecting the external pressure tank to the Condair RO-E+ 200/300 pure water system

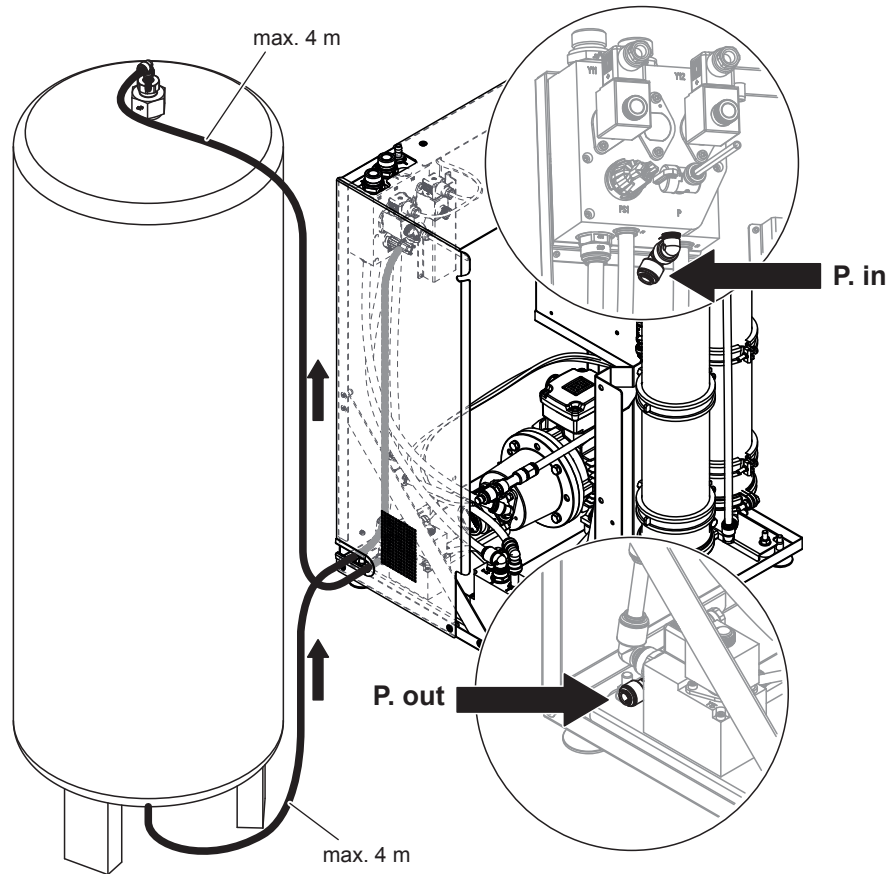

Fig. 25: Connecting the external pressure tank to the Condair RO-E+ 200/300 pure water system (figure shows RO-E+ 200)

Connecting several external pressure tanks to the Condair RO-E+ pure water system

Up to three external pressure tanks can be connected to a RO-E+ pure water systems according to the schematic diagram shown in [Fig. 26](#).

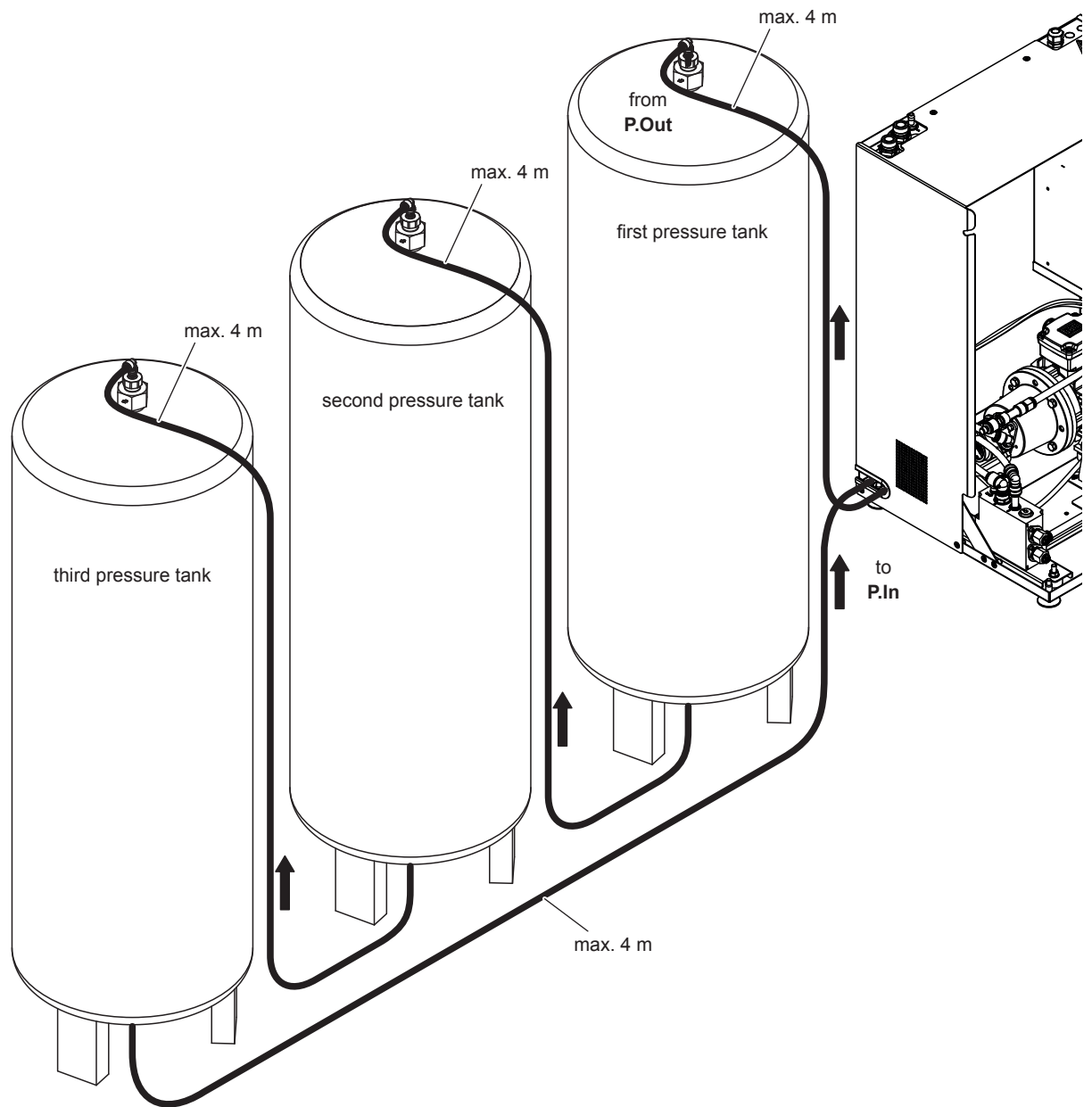

Fig. 26: Connecting several external pressure tanks to the Condair RO-E(+) pure water system

5.4.16 Connecting the optional pressure tank safety valve

Important installation notes:

- Only use the supplied black John Guest hoses and fittings supplied with the safety valve.
- Only use the original John Guest hose cutter to cut the black John Guest hoses to length.
- Make sure hoses are free of score marks and burrs before pushing the hoses into the fittings to prevent damage to the O-rings in the fittings.
- The safety valve must always be installed in a vertical position with the inlet connection at the bottom.
- The length of the hose from the connection on the internal or external pressure tank to the inlet connection on the safety valve must be as short as possible.
- For Condair RO-E(+) 40/100 pure water systems, the safety valve must always be mounted right above the Condair RO-E(+) pure water system so that the pipe from the inlet connection at the safety valve has a constant downslope to the connection at the Condair RO-E(+) pure water system.
- For Condair RO-E 200/300 pure water systems, the safety valve must be mounted above the external pressure tank so that the line from the inlet connection at the safety valve has a constant downslope to the connection at the pressure tank inlet.
- For Condair RO-E+ 200/300 pure water systems with one or more external pressure tanks, the safety valve is connected directly to the upper connection of the (first) external pressure tank.
- The drain hose must be routed from the connection on the safety valve with a constant downslope to the open funnel with trap in the room. Just before the funnel the drain hose must be fixed in such a way, that the end of the drain hose does not touch the funnel (min air gap 2 cm) and can not slip out of the funnel.

5.4.16.1 Connecting the pressure tank safety valve to the Condair RO-E(+) 40/100 pure water systems

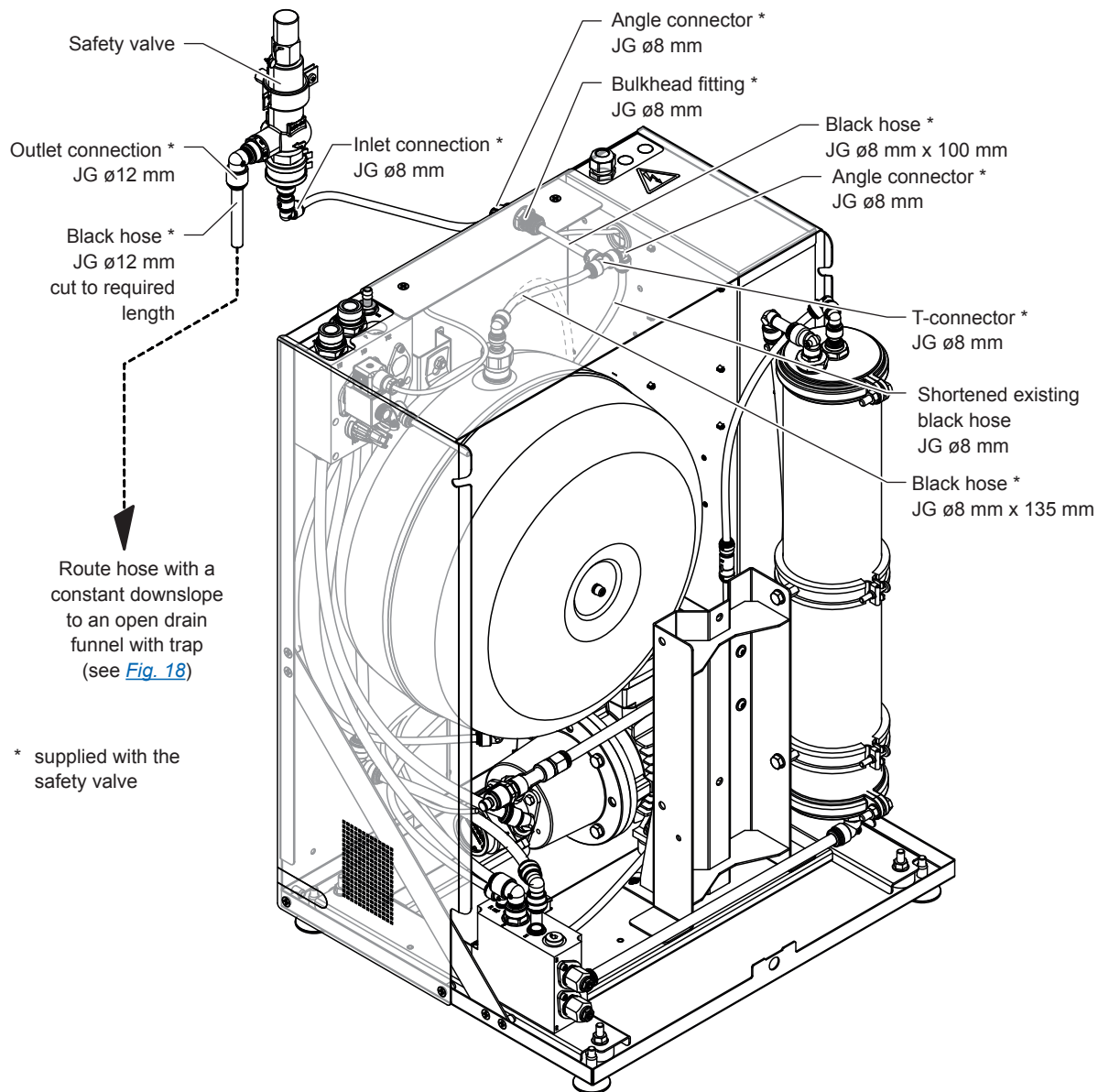

Fig. 27: Connecting the pressure tank safety valve to the Condair RO-E(+) 40/100 pure water system (figure shows RO-E 100)

Connection

1. Install the JG8 bulkhead fitting with the angle connector in the rear wall of the housing of the Condair RO-E(+) 40/100 pure water system.
2. Connect the $\varnothing 8$ mm JG hose to the elbow connector of the JG bulkhead fitting and route the hose to the inlet of the safety valve, cut the hose to length and connect it to the elbow connector of the safety valve.
3. Loosen the $\varnothing 8$ mm JG hose on the upper connection of the internal pressure tank and shorten it by 235 mm.
4. Connect the $\varnothing 8$ mm JG T-connector with installed angle connector with the hoses shown in [Fig. 27](#).
5. Connect the $\varnothing 12$ mm JG hose to the outlet connection of the safety valve and route the hose with constant downslope to the open drain funnel with trap.

5.4.16.2 Connecting the pressure tank safety valve to the Condair RO-E+ 200/300 pure water systems

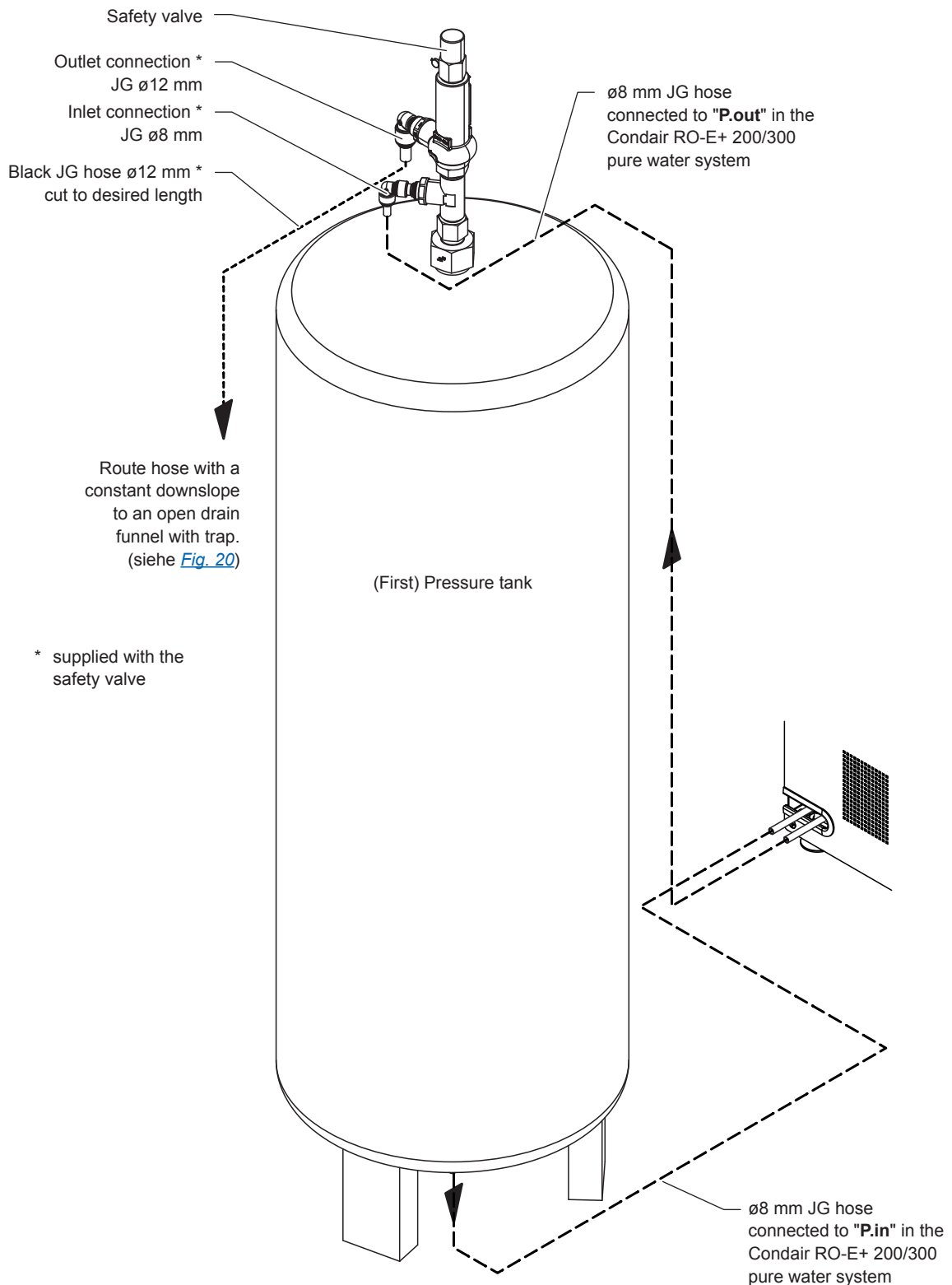

Fig. 28: Connecting the pressure tank safety valve to the Condair RO-E+ 200/300 pure water systems

Connection

1. Connect the JG hose $\varnothing 8$ mm from the "P.out" port of the Condair RO-E+ 200/300 pure water system to the JG8 angle connector of the safety valve as shown in [Fig. 28](#).
2. Connect the supplied $\varnothing 12$ mm JG hose to the JG12 outlet connection of the safety valve and route the hose with constant downslope to the open drain funnel with trap as shown in [Fig. 28](#).

5.4.16.3 Connecting the pressure tank safety valve to the Condair RO-E 200/300 pure water systems

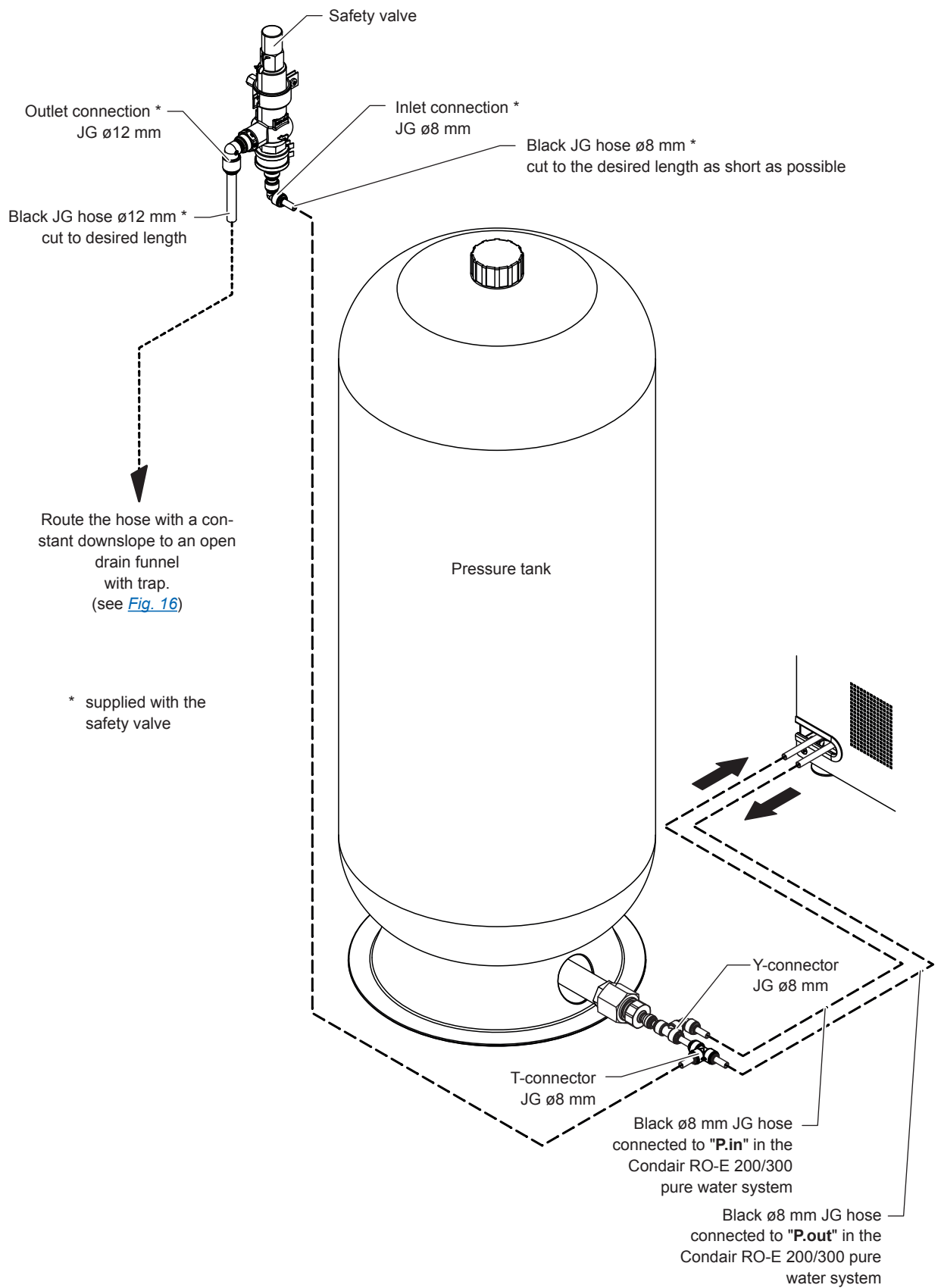

Fig. 29: Connecting the pressure tank safety valve to the Condair RO-E 200/300 pure water systems

Connection

1. Connect the JG hose $\varnothing 8$ mm from the "P.out" port of the Condair RO-E 200/300 pure water system via the JG8 T-connector to the JG8 angle connector of the safety valve (see [Fig. 29](#)).
2. Connect the supplied $\varnothing 12$ mm JG hose to the JG12 outlet connection of the safety valve and route the hose with constant downslope to the open drain funnel with trap (see [Fig. 29](#)).

5.5 Electrical installation

5.5.1 Notes on electrical installation



DANGER!
Risk of electric shock!

The Condair RO-E(+) pure water system is mains powered. Live parts may be exposed when the control compartment or the terminal box of the pump motors/are open. Touching live parts may cause severe injury or danger to life.

Prevention: Before carrying out any work on the components of the Condair RO-E(+) pure water system make sure the system is disconnected from the mains and secured against inadvertent power-up.

Important: The frequency converter in the Condair RO-E(+) pure water system contains capacitors. These can remain charged with a potentially deadly voltage for a certain period of time after the Condair RO-E(+) pure water system has been disconnected from the power supply. Therefore, wait at least 10 minutes after disconnecting the power supply. Then make sure the appropriate contacts on the frequency converter and the terminals on the pump motor are free of voltage before starting any work on these components!



CAUTION!

The electronic components inside the control compartment of the Condair RO-E(+) pure water system, the external control unit and the control compartment/control unit of the corresponding Condair humidifier are sensitive to electrostatic discharge. Before carrying out installations work inside these units, appropriate measures must be taken to protect the electronic components against damage caused by electrostatic discharge (ESD protection).

- **All work relating to the electrical installation may only be carried out by a Condair service technician or by service personnel trained and authorized by Condair.** It is the owner's responsibility to verify proper qualification of the personnel.
- The electrical installation must be carried out according to the appropriate wiring diagram (see [Section 7.4](#) and [Section 7.5](#)), the notes on electrical installation as well as the applicable local regulations. All information given in the wiring diagram and notes must be followed and observed.
- All cables must be led into the unit, via appropriate cable strain relief or cable glands. The cable for the optional leakage sensor can be led into the Condair RO-E(+) pure water system from top via a cable gland or from the bottom via the opening in the housing cover (fix cable with a cable tie to the unit cover).
- Make sure all cables are adequately fixed over their entire length, do not rub on any components or become a tripping hazard.
- Observe and maintain maximum cable length and required cross section per wire according to local regulations.
- The mains supply voltages must match the respective voltage and fuse requirements as stated in [Section 5.5.3](#).

5.5.2 Electrical connections of the water softeners

Single water softener "SoftCab DR25C EF"

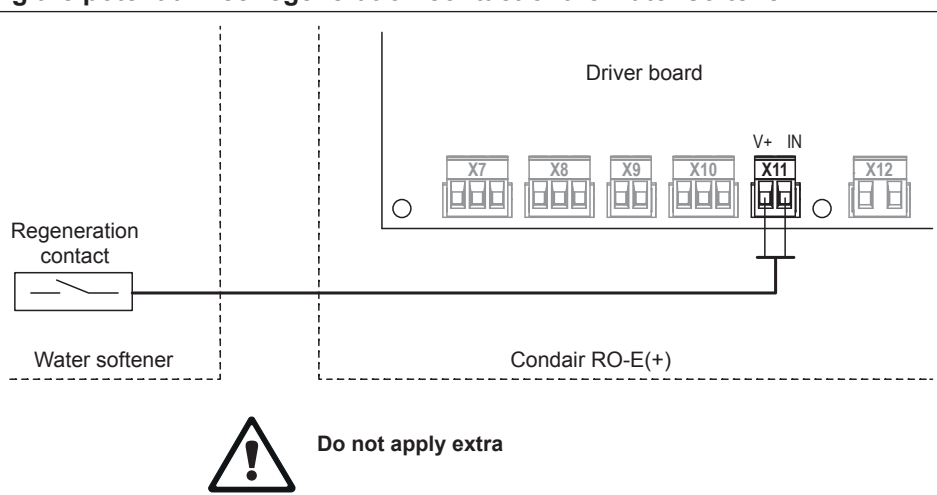
Power supply
The water softener SoftCab DR25C EF is connected to the mains via the supplied power adapter.
Connecting the potential free regeneration contact of the water softener
 <p>Do not apply extra</p>
Connect the potential free regeneration contact of the water softener SoftCab DR25C EF according to the wiring diagram above to terminals "V+" and "IN" of terminal block "X11" on the driver board of the Condair RO-E(+) pure water system.

Double water softener "DSP25 EF"

Power supply
The water softener DSP25 EF is connected to the mains via the supplied power adapter.

Double water softener S150 XP

The S150 XP double water softener does not require any electrical connections.

5.5.3 Electrical connections of the Condair RO-E(+) pure water system

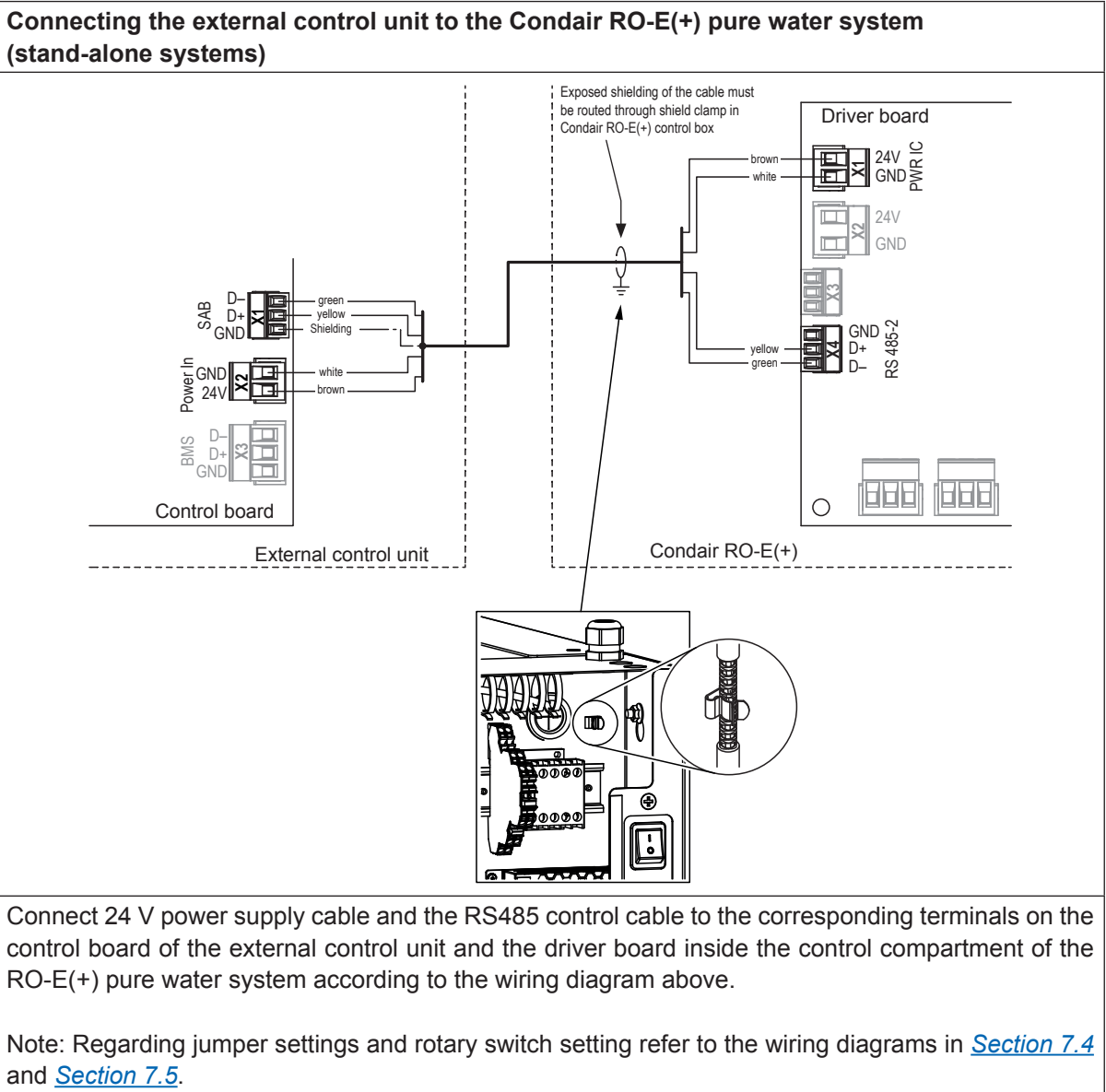

Connecting the Condair RO-E(+) pure water system to the Condair RS steam humidifier (integrated system)

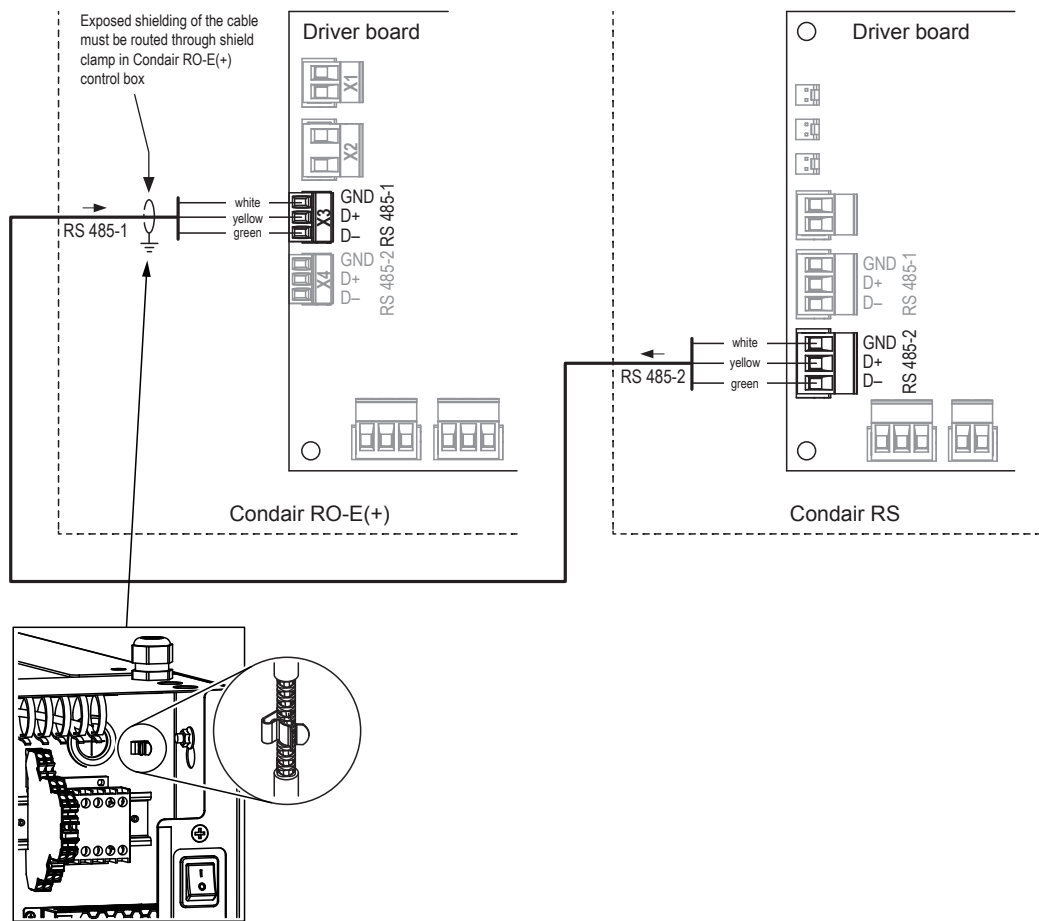

Connect RS485 control cable to terminal "RS485-1" ("X3") on the driver board inside the control compartment of the Condair RO-E(+) pure water system and to the terminal "RS485-2" on the driver board inside the control compartment of the Condair RS steam humidifier according to the wiring diagram shown above.

Note: Regarding jumper settings and rotary switch setting refer to the wiring diagram in [Section 7.4](#) and [Section 7.5](#).

Connecting the optional leak sensor

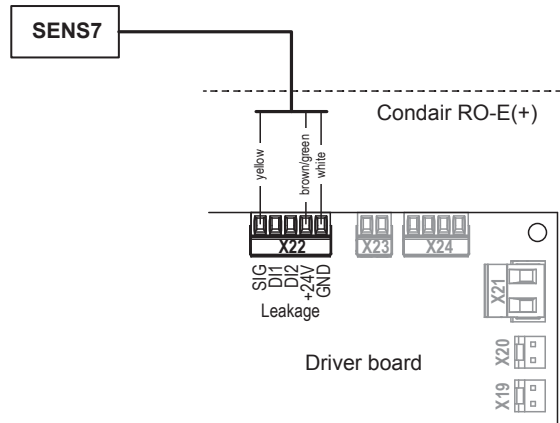

Connect the optional leak sensor "SENS7" has to be connected according to the wiring diagram above to the corresponding terminals of the plug "X22" on the driver board in the control compartment of the Condair RO-E(+) pure water system.

Connecting the optional remote operating and fault indication

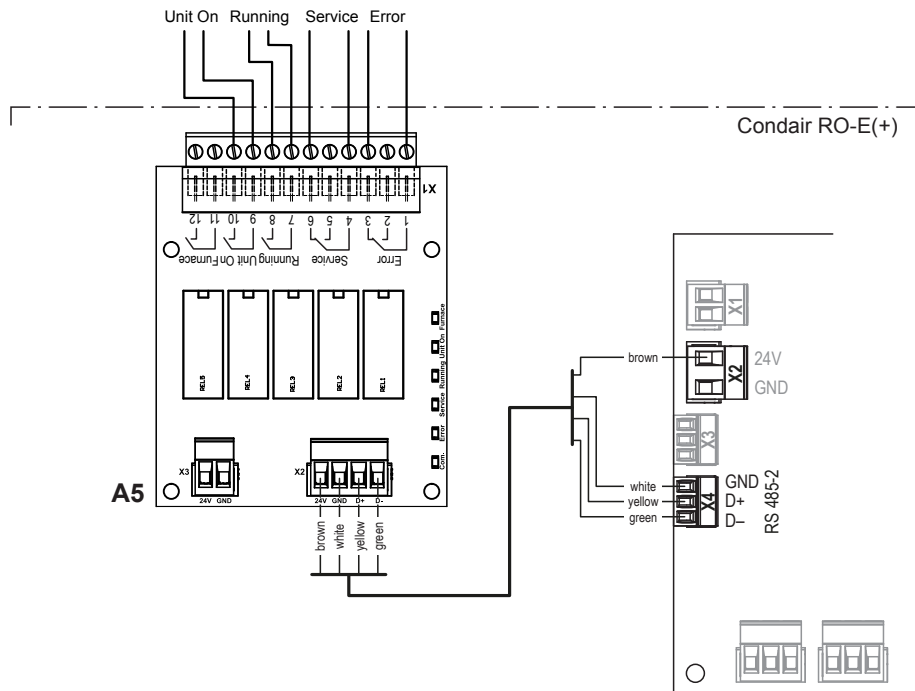

Connect the remote operating and fault indication board "A5" to the corresponding terminals on the driver board using the four-core cable supplied, as shown in the wiring diagram above.

The remote operating and fault indication board contains five potential-free relay contacts for the connection of the following operating and fault indications:

- "Error" (Terminal 1 and 3):
This relay is activated if an error is present.
- "Service" (Terminal 4 and 6):
This relay is activated when the set maintenance interval time has expired (default setting) or a warning is pending (must be configured accordingly in the control software)
- "Running" (Terminal 7 and 8):
This relay closes as soon as the Condair RO-E(+) pure water system produces reverse osmosis water.
- "Unit on" (Terminal 9 and 10):
This relay closes as soon as the voltage supply to the Condair RO-E(+) pure water system is switched on.
- "Furnace":
This relay is not supported.

The connecting cable(s) of the relays are routed downwards through the cable entry out of the control compartment and from there downwards out of the device.

The **maximum contact loading is 250V/8A**.

Appropriate suppressor modules are to be used for the switching of relays and miniature contactors.

**230 V / 50-60 Hz power supply
for Condair RO-E(+) pure water systems with power socket**

Condair RO-E(+) pure water systems with power socket inlet must be connected to a corresponding wall socket with a protective earth conductor using the power cable supplied (for wall socket details refer to [Section 5.2](#)).

Important: Before connecting, make sure that the device voltage (see rating plate) matches the mains voltage.

Connection of the second protective earth conductor (mandatory)

To ensure safety in connection with the frequency converter, a second protective earth conductor must be connected to the corresponding protective earth terminal in the control compartment of the Condair RO-E(+) pure water system. The cross-section of the protective conductor must comply with applicable local regulations.

1. Loosen the six screws securing the Condair RO-E(+) unit cover and remove the cover..
2. Break out the pre-cut passage on the right side of the Condair RO-E(+) unit cover. Attach the edge protector as shown in the figure below and press it completely into the curve.

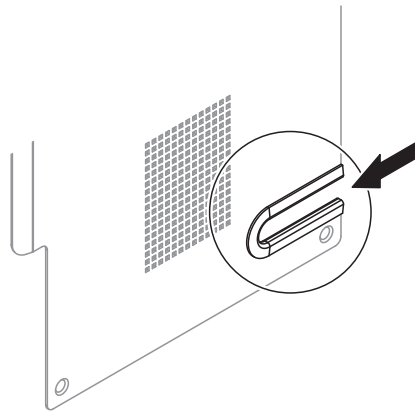

3. Connect the cable of the second protective earth conductor to the protective earth terminal in the control compartment of the Condair RO-E(+) pure water system according to the following diagram.

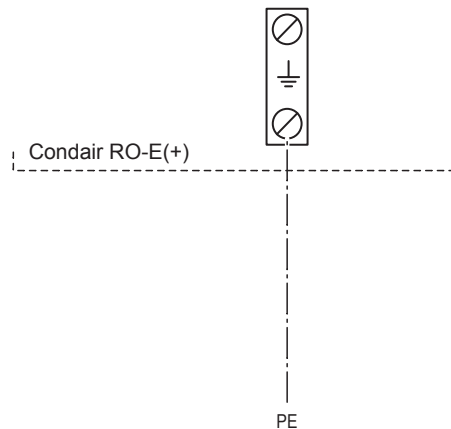

**High leakage current!
Connect a second
protective earth conductor.**

4. Route the protective earth conductor cable along the cable harness through the cable entry of the control compartment down of the device.
5. Secure the protective earth conductor cable to the cable harness and to the cable tie holder at the bottom of the device using cable ties.
6. Connect the second protective earth conductor to the nearest potential equalization point.

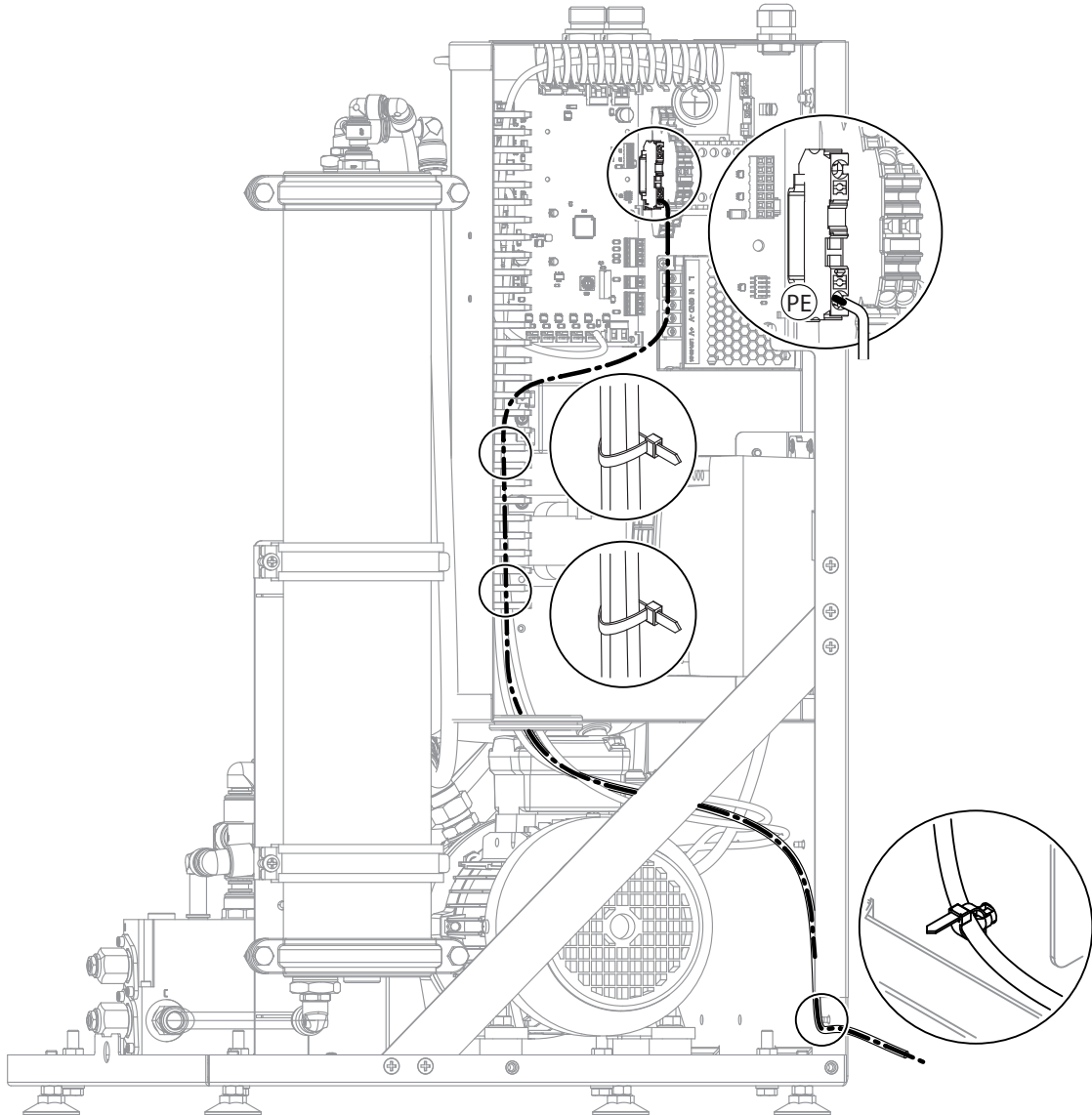

7. Attach the cover of the Condair RO-E(+) pure water system. Make sure that the protective earth conductor cable is routed properly through the broken-out passage in the cover. Fix the cover with the six screws.

230 V / 50-60 Hz or 110 V / 60 Hz voltage supply, hardwired

1. Loosen the six screws securing the Condair RO-E(+) unit cover and remove the cover..
2. Break out the pre-cut passage on the right side of the Condair RO-E(+) unit cover. Attach the edge protector as shown in the figure below and press it completely into the curve.

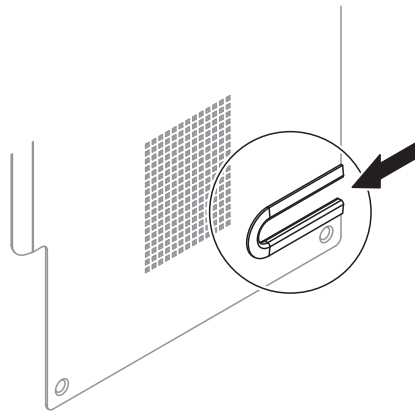

3. Connect the mains cable (L1, N, PE) and the cable of the second protective earth conductor (PE, mandatory) to the corresponding terminals inside the control box of the Condair RO-E(+) pure water system according to the following diagram.

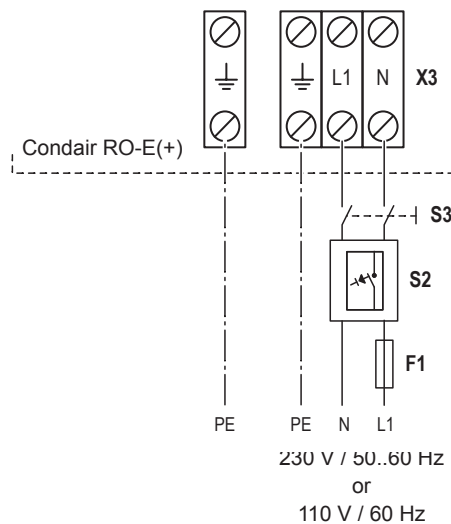

High leakage current!
Connect 2x protective earth conductor.

The installation of the **fuse "F1"** (fuse rating see [Section 5.2](#)) and the **electrical isolator "S3"** (all pole disconnecting device with a minimum contact clearance of 3 mm, supplied by others) in the mains supply line are mandatory.

For safety reasons the additional installation of a **residual current circuit breaker "S2"** in the mains supply line (supplied by others, requirements see [Section 5.2](#)) is recommended. However, the local electrical installation regulations must be observed and adhered to.

The electrical isolator must be mounted in direct proximity of the Condair RO-E(+) pure water system (max. distance 40" (1 m) and must be easily accessible in a height between 40" (1.0 m) and 59" (1.5 m).

CAUTION! Make sure the voltage indicated on the rating plate meets the local mains voltage. Otherwise, do not connect the unit.

The cross-section of the mains cable and the protective earth cable must comply with the applicable local regulations.

4. Route the mains cable and protective earth cable along the cable harness through the cable entry of the control compartment down of the device.
5. Secure both cables to the cable harness and to the cable tie holder at the bottom of the device using cable ties.
6. Connect the both protective earth conductor to the nearest potential equalization point.

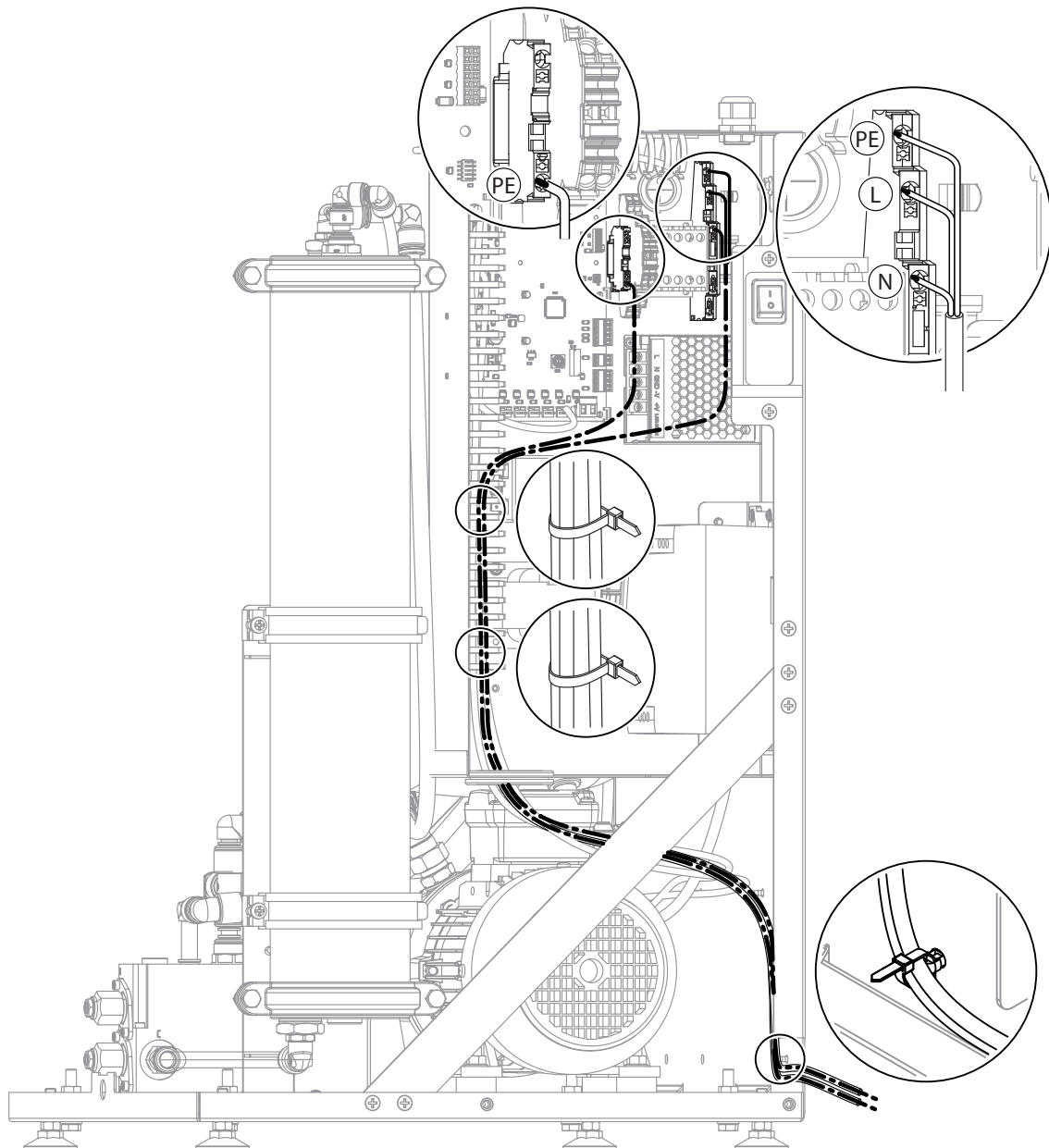

7. Attach the cover of the Condair RO-E(+) pure water system. Make sure that the two cables are routed properly through the broken-out passage in the cover. Fix the cover with the six screws.

6 Product specification

6.1 Technical data

6.1.1 Technical data RO-E(+) pure water system

		Model			
		RO-E(+) 40	RO-E(+) 100	RO-E(+) 200	RO-E(+) 300
Pure water output at 10°C against 1 bar	RO-E	78 l/hr	183 l/hr	350 l/hr	350 l/hr
	RO-E+	44 l/hr	108 l/hr	218 l/hr	325 l/hr
Pure water output at 15°C against 1 bar	RO-E	92 l/hr	218 l/hr	350 l/hr	350 l/hr
	RO-E+	52 l/hr	130 l/hr	260 l/hr	350 l/hr
Max. pure water output per day at 15°C against 1 bar	RO-E	2.21 m ³ /day	5.23 m ³ /day	8.40 m ³ /day	8.40 m ³ /day
	RO-E+	1.25 m ³ /day	3.12 m ³ /day	6.24 m ³ /day	8.40 m ³ /day
Recovery hard water		50 %			
Recovery softened water		70 %			
Admissible water pressure range at the inlet of the Condair RO-E(+)		1.6 - 6 bar ¹⁾			
Admissible inlet water temperature		5 - 20°C			
Salt rejection rate		95 to 98 %			
RO membrane type	RO-E	2606403	2606404	2606404	2606404
	RO-E+	50001	50039	50039	50039
Nominal volume pressure tank	RO-E	Internal 25 l	Internal 25 l	External 112 l	External 112 l
	RO-E+	Internal 25 l	Internal 25 l	External 140 l	External 140 l
Pump capacity		421 l/hr	809 l/hr	1000 l/hr	1221 l/hr
Permeate outlet pressure		1.5 - 5.0 bar			
Hydraulic connections					
Inlet water connection		G 3/4" (outside thread)			
Pure water connection		G 3/4" (outside thread)			
Drain connection		ø10 mm (hose connection)			
Electric connections					
Power supply 230 VAC		230 VAC ±10% / 50-60 Hz			
Electrical power		640 VA	640 VA	750 VA	900 VA
Current consumption		2.5 A	2.5 A	2.7 A	2.9 A
Power supply 110 VAC		110 VAC ±10% / 60 Hz			
Electrical power		640 VA	640 VA	750 VA	900 VA
Current consumption		4.8 A	4.8 A	6.5 A	6.7 A
Sound pressure level					
Without cover		max. 60 dB	max. 65 dB	max. 67 dB	max. 70 dB
With insulated cover		max. 55 dB	max. 58 dB	max. 59 dB	max. 60 dB
Housing dimensions					
Height		792 mm			
Width		555 mm			
Depth		474 mm			

	Model			
	RO-E(+) 40	RO-E(+) 100	RO-E(+) 200	RO-E(+) 300
Housing dimensions with optional housing cover				
Height	792 mm			
Width	587 mm			
Depth	484 mm			
Weights				
Netweight	63 kg	64 kg	96 kg	102 kg
Ambient conditions operation				
Admissible ambient temperature	5 - 40 °C			
Admissible ambient humidity	10 - 80 %rh, non-condensing			
Ambient conditions storage				
Admissible ambient temperature	5 - 40 °C			
Admissible ambient humidity	10 - 75 %rh, non-condensing			
Protection class				
Control compartment	IP21			
Test certificates				
Test certificates	CE, DGUV, EAC, BTL			

¹⁾ If filters/water softeners are installed upstream of the Condair RO-E(+) pure water system, the minimum pressure before these components must be 1 bar higher than the specified minimum pressure.

6.1.2 Internal pressure tank 25 l for Condair RO-E(+) 40 & 100

Nominal volume	25 l
Usable volume at 5 bar	18 l
Dimensions	Height: 472 mm, Width: 251 mm
Netweight	approx. 8.5 kg
Max. permissible pressure	10 bar
Tank pre-pressure	0.8 bar
Pressure tank connection	JG ø8 mm

6.1.3 External pressure tank 140 l for Condair RO-E+

Nominal volume	140 l
Usable volume at 5 bar	102 l
Dimensions	Ø: 420 mm, Height: 1.430 mm
Netweight	approx. 34 kg
Max. permissible pressure	10 bar
Tank pre-pressure	0.8 bar
Pressure tank connection	JG ø8 mm

6.1.4 External pressure tank 112 l for Condair RO-E 200/300

Nominal volume	112 l
Usable volume at 5 bar	79 l
Dimensions	Ø: 410 mm, Height: 1.120 mm
Netweight	approx. 11.2 kg
Max. permissible pressure	8.6 bar
Tank pre-pressure	0.8 bar
Pressure tank connection	JG ø8 mm

7 Appendix

7.1 Dimensional drawing Condair RO-E(+) pure water system

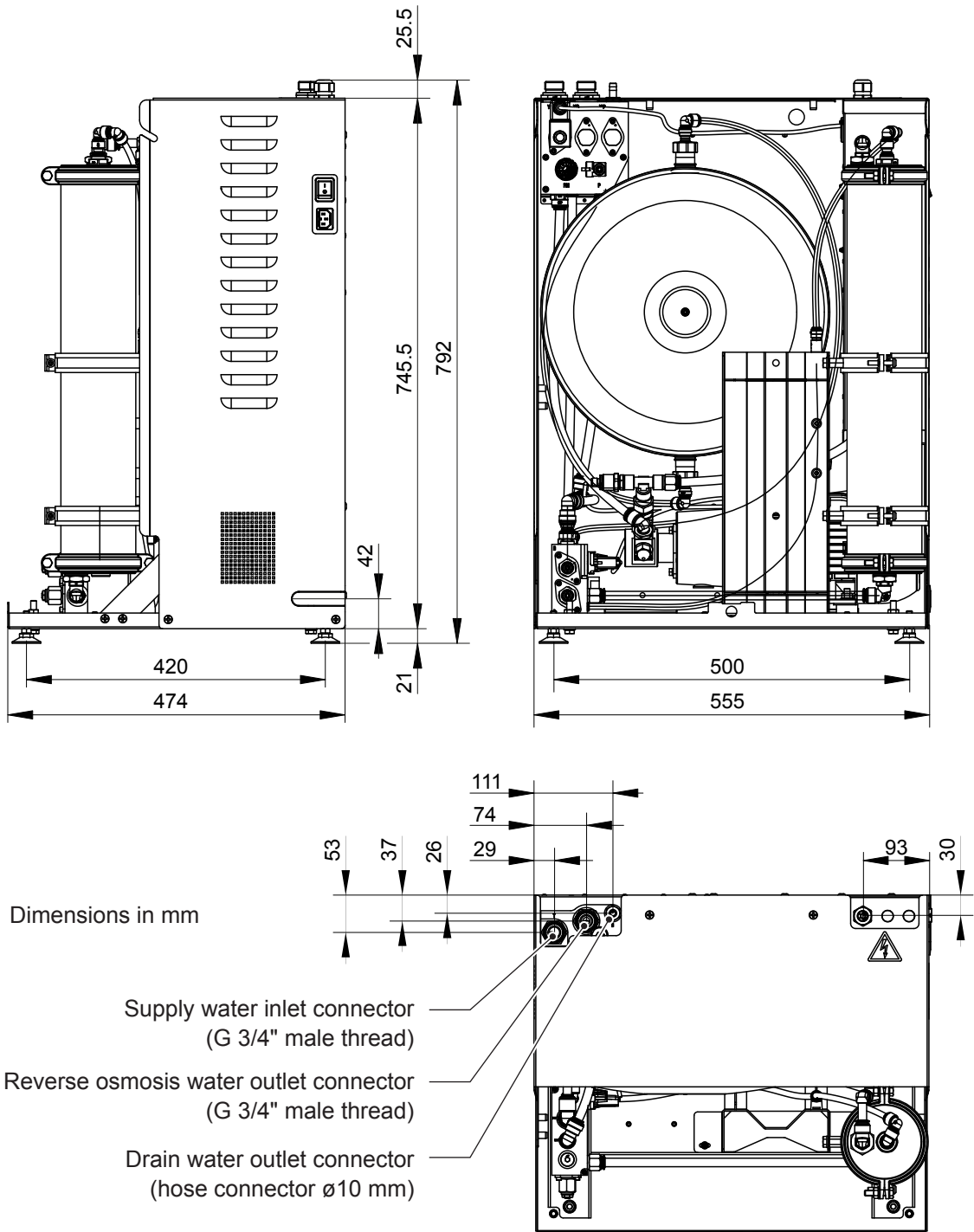

7.2 Dimensional drawing external pressure tank 140 l

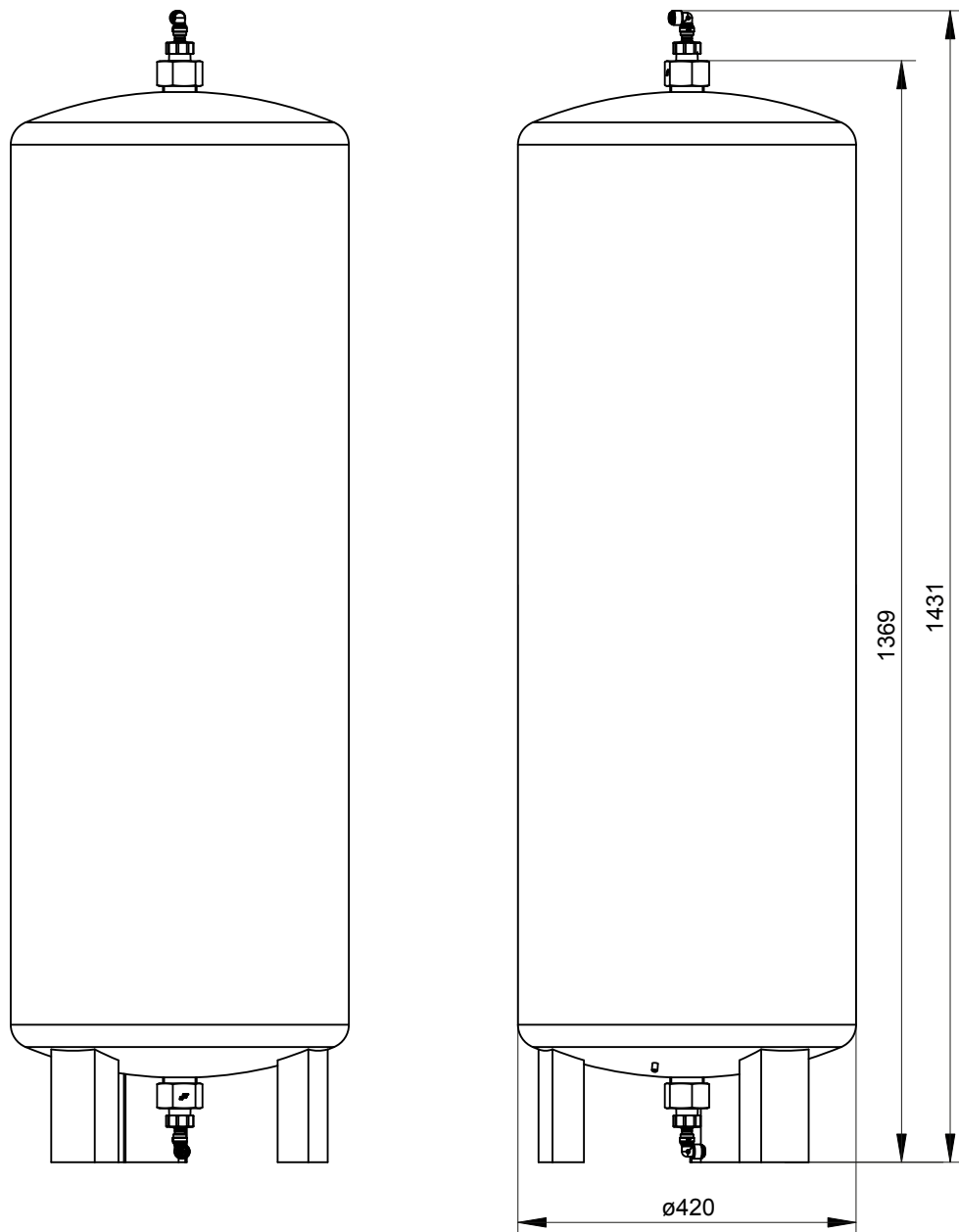

Dimensions in mm

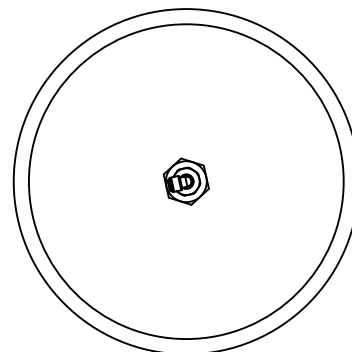

7.3 Dimensional drawing external pressure tank 112 l

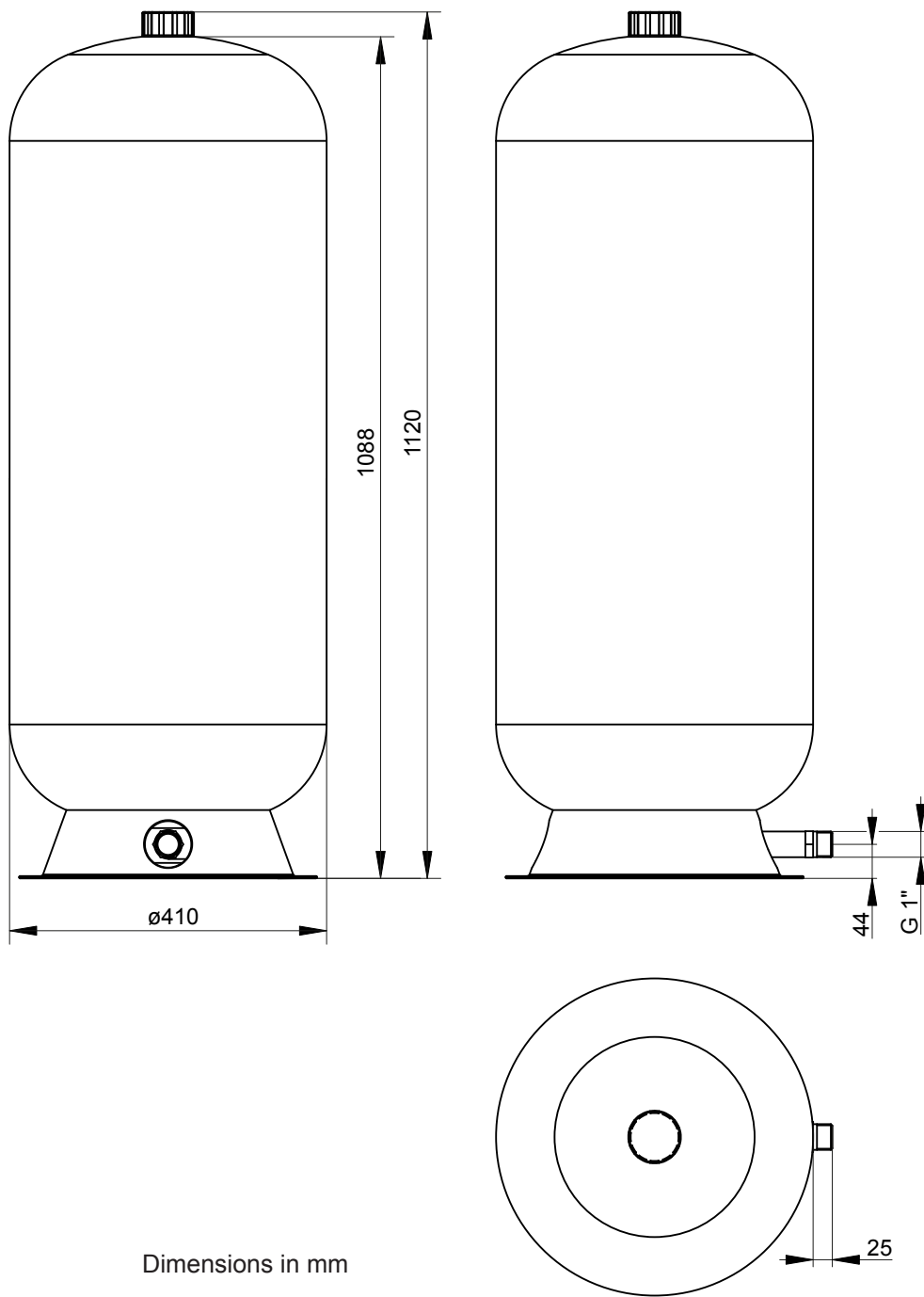

7.4 Wiring diagram Condair RO-E(+) pure water system - 230 V

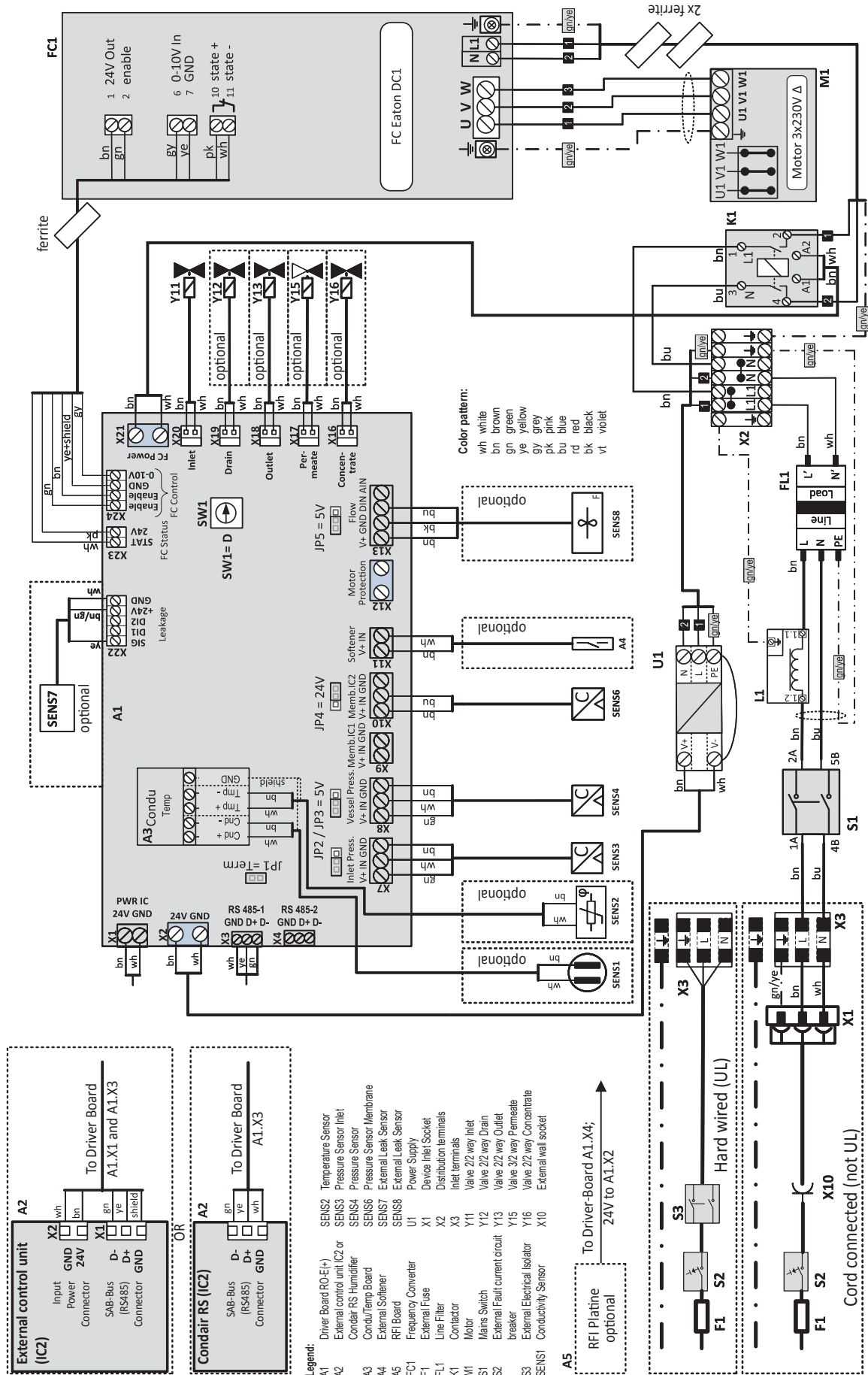

7.5 Wiring diagram Condair RO-E(+) pure water system - 110 V

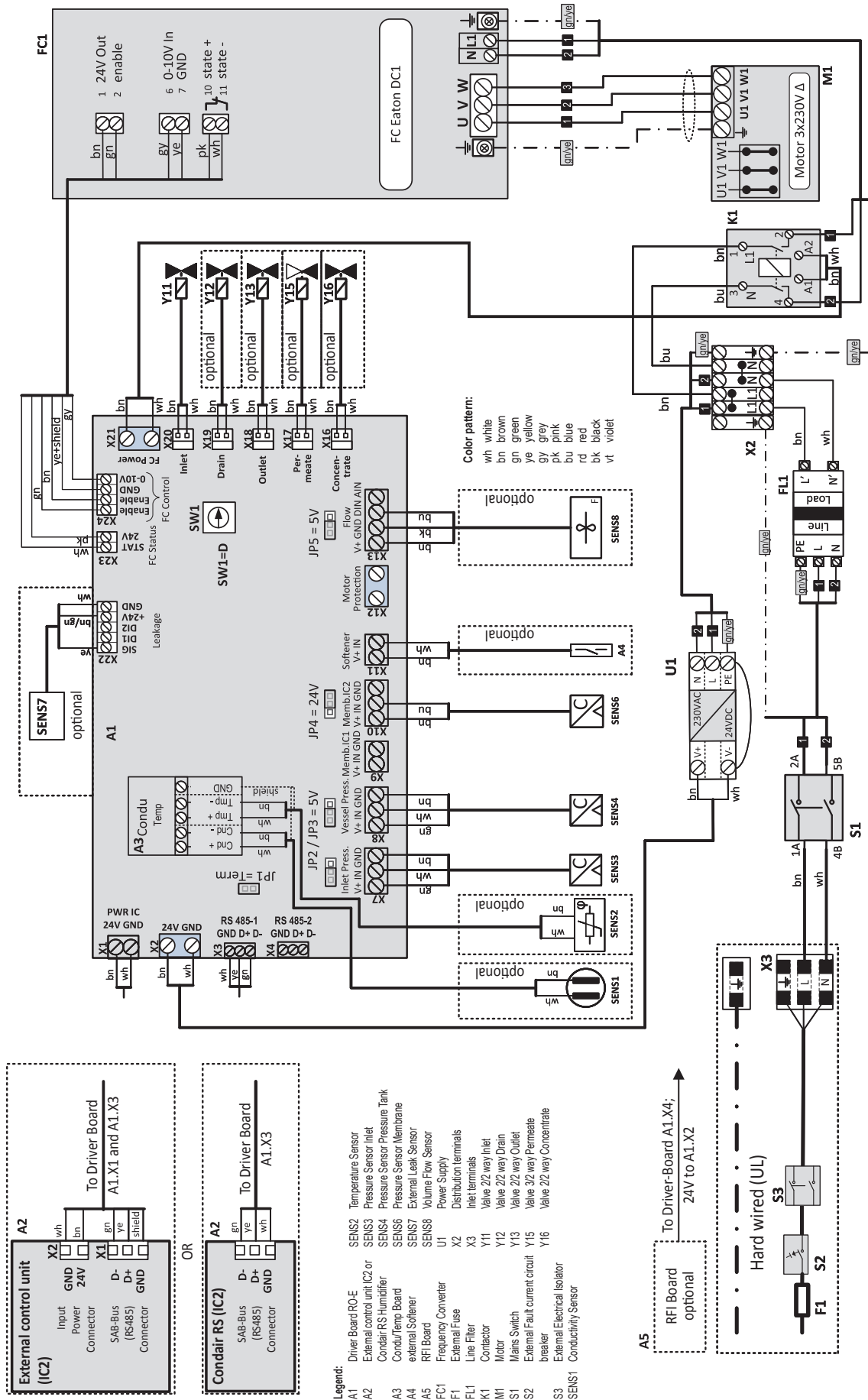

7.6 Hydraulic diagram Condair RO-E pure water system

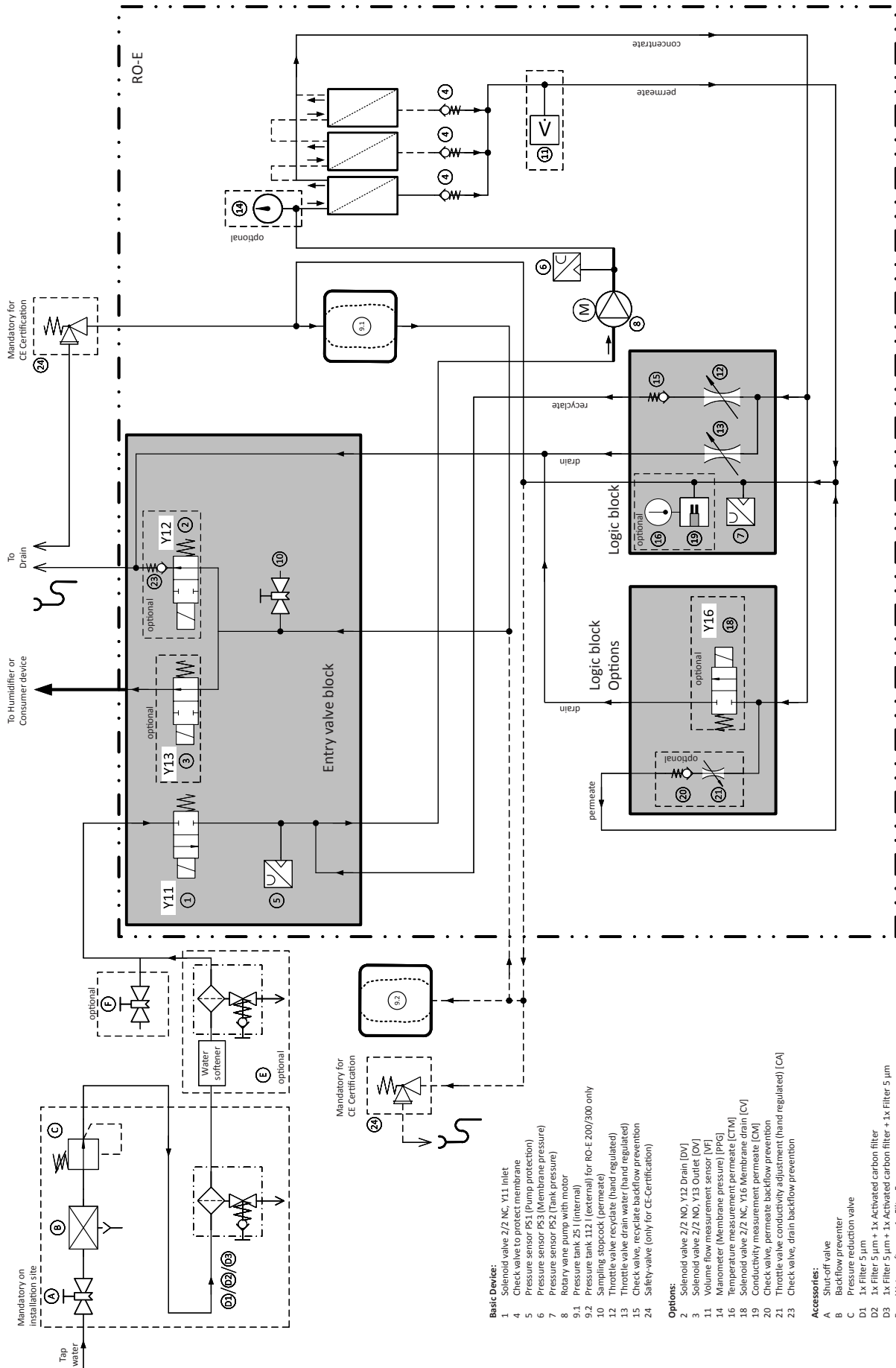

7.7 Hydraulic diagram Condair RO-E+ pure water system

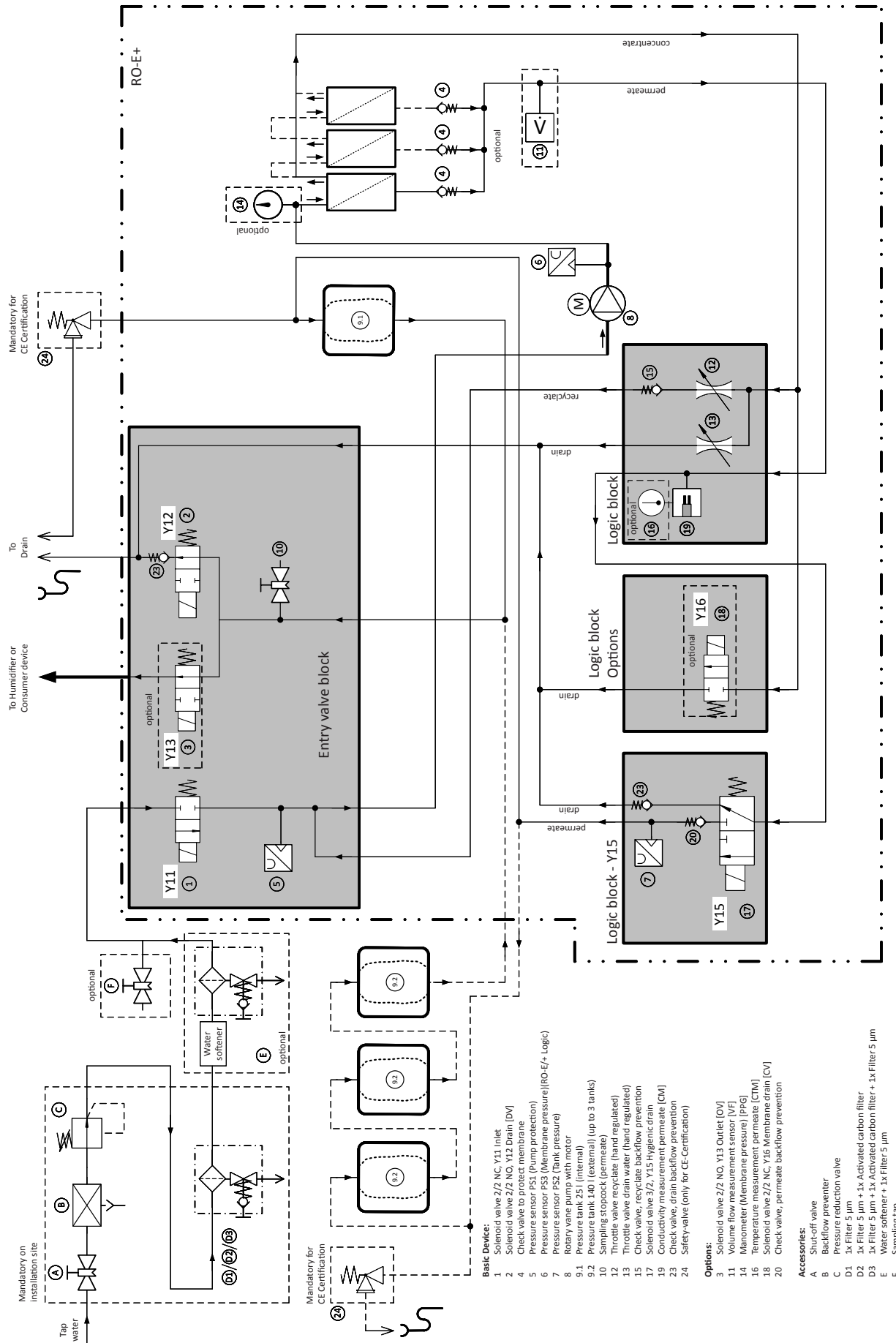

Notes

Notes

CONSULTING, SALES AND SERVICE:



CH94/0002.00

Condair Group AG
Gwattstrasse 17, 8808 Pfäffikon SZ, Switzerland
Phone +41 55 416 61 11, Fax +41 55 588 00 07
info@condair.com, www.condairgroup.com

The Condair logo, consisting of a stylized wave symbol followed by the word 'condair' in a bold, lowercase, sans-serif font.