

OPERATION MANUAL

Pure Water System
Condair **RO-E**

Humidification, Dehumidification
and Evaporative Cooling

 **condair**

Thank you for choosing Condair

Installation date (MM/DD/YYYY):

Commissioning date (MM/DD/YYYY):

Site:

Model:

Serial number:

Proprietary Notice

This document and the information disclosed herein are proprietary data of Condair Group AG. Neither this document, nor the information contained herein shall be reproduced, used, or disclosed to others without the written authorization of Condair Group AG, except to the extent required for installation or maintenance of recipient's equipment.

Liability Notice

Condair Group AG does not accept any liability due to incorrect installation or operation of the equipment or due to the use of parts/components/equipment that are not authorized by Condair Group AG.

Copyright Notice

© Condair Group AG, All rights reserved.

Technical modifications reserved

Contents

1	Introduction	5
1.1	Read me first!	5
1.2	Notes on the operation manual	5
2	For your safety	7
2.1	General safety guidelines	7
2.2	Intended use	7
2.3	Danger that may arise from the Condair RO-E(+) pure water system	8
2.4	Ensure safe operation	9
2.5	Hygiene	10
2.5.1	Guidelines to ensure your system stays clean and prevent the growth of Legionella	11
3	Product Overview	12
3.1	Product overview Condair RO-E pure water systems	12
3.1.1	Model overview Condair RO-E pure water systems	12
3.1.2	Condair RO-E construction	14
3.2	Product overview Condair RO-E+ pure water systems	15
3.2.1	Model overview Condair RO-E+ pure water systems	15
3.2.2	Condair RO-E+ construction	17
3.3	Functional description Condair RO-E(+)	18
3.4	System overview	19
4	Initial commissioning of the RO-E(+)	21
4.1	Requirements	21
4.2	Quick test of electrical installation	21
4.3	First steps after the Condair RO-E(+) pure water system has been installed	21
4.4	Configuration of the control software	22
5	Operation	23
5.1	Start-up sequence for daily operation	23
5.2	Notes on operation	24
5.2.1	Inspections during operation	24
5.2.2	Flushing of the internal water supply system and the mebrane(s)	26
5.2.3	Performing a pressure relief of the Condair RO-E(+) pure water system	27
5.3	Shut-down the system	28
6	Operating the Condair RO-E(+) control software	29
6.1	Home screen	29
6.1.1	Device and error status indication field	30
6.1.2	Tank capacity indication field	31
6.1.3	Maintenance indication field	31
6.2	Information functions in the "Help" Menu	32
6.2.1	Accessing the "Help" menu	32
6.2.2	Query operating states in the "About" submenu	33
6.2.3	Quick access to setting parameters in the "Quick Access" submenu	34
6.3	Configuration	35
6.3.1	Settings and features in the "General" submenu	35
6.3.1.1	Accessing the "General" submenu	35
6.3.1.2	Determine language and system of units in the "Region" submenu	35
6.3.1.3	Date and time settings in the "Date & Time" submenu	36
6.3.1.4	Read in parameter settings in the "Backup" submenu	36
6.3.1.5	Activate/Deactivate password protection in the "Password Settings" submenu	37
6.3.1.6	Set the brightness of the touchscreen and the LED in the "Brightness" submenu	37
6.3.2	Settings and features in the "Maintenance" submenu	38

6.3.2.1	Accessing the "Maintenance" submenu	38
6.3.2.2	Reset functions in the "Reset" submenu	38
6.3.2.3	Settings in the "Settings" submenu	38
6.3.2.4	Software update in the "Update" submenu	39
6.3.2.5	View and export malfunctions and maintenance histories in the "Histories" submenu	39
6.3.2.6	Load and export the error log file in the "Error Analyzer" submenu	40
6.3.2.7	Start operating data recording in the "USB Data Logger" submenu	40
6.3.2.8	View operating states in the submenu "Diagnostics > RO Input Diagnostics"	41
6.3.2.9	Checking the relays of the remote operating and fault indication board in the "Diagnostics > RFI Diagnostics" submenu	42
6.3.3	Communication settings in the "Network" submenu	43
6.3.3.1	Accessing the "Network" submenu	43
6.3.3.2	Settings in the "IP Settings" submenu	44
6.3.3.3	Settings in the "IoT Settings" submenu	45
6.3.3.4	Settings in the "Modbus Settings" submenu	45
6.3.3.5	Settings in the "BACnet Settings" submenu	46
6.3.3.6	Settings in the "Remote Fault Indication" submenu	46
7	Maintenance	47
7.1	Important notes on maintenance	47
7.2	Maintenance work	48
7.2.1	Maintenance indication	48
7.2.2	Maintenance list	48
7.3	List of preventive component replacements	49
7.4	Maintenance and replacement of components	50
7.4.1	Maintenance of the membrane(s)	50
7.4.1.1	Determination of the desalination rate	50
7.4.1.2	Replacing the membrane(s)	51
7.4.2	Flushing of a new membrane(s)	54
7.4.3	Adjustment and maintenance of throttle valves	56
7.4.3.1	Overview and description of the throttle valves	56
7.4.3.2	Table for adjusting and checking the throttle valves	57
7.4.3.3	Maintenance of throttle valves	58
7.4.4	Replacement of the filter cartridge(s) of the pre-filter(s)	59
7.4.5	Maintenance work to be carried out on the optional water softener	60
7.5	Maintenance history	60
7.6	Reset maintenance counter	60
7.7	Performing a software update	60
8	Fault elimination	61
8.1	Important notes on fault elimination	62
8.2	Fault indication	62
8.3	Malfunction list	64
8.4	Malfunctions without indication	71
8.5	Saving fault and service histories to a USB stick	72
8.6	Resetting malfunction indication	73
9	Taking out of service/Disposal	74
9.1	Taking out of service	74
9.2	Disposal/Recycling	74

1 Introduction

1.1 Read me first!

Thank you for choosing the **Condair RO-E(+) pure water system**.

The Condair RO-E(+) pure water system incorporates the latest technical advances and meets all recognized safety standards. Nevertheless, improper use of the Condair RO-E(+) pure water system may result in danger to the user or third parties and/or damage to property.

To ensure a safe, proper, and economical operation of the Condair RO-E(+) pure water system, please observe and comply with all information and safety instructions contained in the present documentation as well as in the separate documentations of the components used together with the Condair RO-E(+) pure water system

If you have questions after reading this documentation, please contact your Condair representative. They will be glad to assist you.

1.2 Notes on the operation manual

Scope

The subject of this operation manual is the Condair RO-E(+) pure water system. The various options and accessories are only described insofar as this is necessary for proper operation of the equipment. Further information on options and accessories can be obtained in the respective instructions.

The information provided in this operation manual is restricted to the **commissioning, operation, maintenance and troubleshooting** of the Condair RO-E(+) pure water system and is intended for **well-trained specialist personnel who are sufficiently qualified for the respective work**.

This operation manual is supplemented by other documents (e.g. installation manual, spare parts list, etc.). Where necessary, cross-references to these publications can be found in this operation manual.

Use of model designation

The model designations are used in this operation manual as follows:

- **RO-E:** If the model designation "RO-E" is used in texts, the corresponding instruction text **only applies to the RO-E model series**.
- **RO-E+:** If the model designation "RO-E+" is used in texts, the corresponding instruction text **only applies to the RO-E+ model series**.
- **RO-E(+):** If the model designation "RO-E(+)" is used in texts, the corresponding instruction text applies to **both model series** (RO-E and RO-E+).

Conventions



CAUTION!

The catchword "**CAUTION**" used in conjunction with the general caution symbol designates notes in this manual that, if neglected, may cause **damage and/or malfunction of the unit or damage to property**.



WARNING!

The catchword "**WARNING**" used in conjunction with the general caution symbol designates safety and danger notes in this manual that, if neglected, may cause **injury to persons**.



DANGER!

The catchword "**DANGER**" used in conjunction with the general caution symbol designates safety and danger notes in this manual that, if neglected, may lead to **severe injury or even death of persons**.

Definitions

– **Raw water:**

The term raw water refers to (untreated) drinking, or tap water without any additives like chlorine, H₂O₂, ozone, etc.

– **Soft water:**

Soft water is the term applied to water produced by the water softener unit. The water softening process replaces hard ions from calcium and magnesium with sodium.

– **Pure water (reverse osmosis water):**

The term pure water or reverse osmosis water (RO water) refers to water partially demineralised by the Condair RO-E(+) pure water system.

Safekeeping

Please safeguard this operation manual in a safe place, where it can be immediately accessed. If the equipment changes hands, this operation manual must be passed on to the new operator.

If the operation manual gets misplaced, please contact your Condair representative.

Language versions

This operation manual is available in other languages. Please contact your Condair representative for information.

2 For your safety

2.1 General safety guidelines

General

Every person working with the Condair RO-E(+) pure water system must have read and understood the installation manual and the operation manual of the Condair RO-E(+) pure water system before carrying out any work.

Knowing and understanding the contents of these manuals is a basic requirement for protecting the personnel against any kind of danger, to prevent faulty operation, and to operate the unit safely and correctly.

All icons, signs and markings applied to the components of the Condair RO-E(+) pure water system must be observed and kept in readable state.

Qualification of personnel

All work described in this operating manual may only be carried out by trained and sufficiently qualified personnel authorized by the owner. It is the owner's responsibility to verify proper qualification of the personnel.

For safety and warranty reasons any action beyond the scope of this manual must only be carried out by a Condair service technician or trained personnel authorized by Condair.

It is assumed that all persons working with the Condair RO-E(+) are familiar and comply with the appropriate regulations on work safety and the prevention of accidents.

The Condair RO-E(+) pure water system may not be used by persons (including children) with reduced physical, sensory or mental abilities or persons with lacking experience and/or knowledge, unless they are supervised by a person responsible for their safety or they received instructions on how to operate the system.

Children must be supervised to make sure that they do not play with the Condair RO-E(+) pure water system.

2.2 Intended use

The Condair RO-E pure water system is intended exclusively for the production of pure water for feeding isothermal humidification systems and the Condair RO-E+ pure water system is intended exclusively for the production of pure water for feeding Condair adiabatic humidification systems within the specified operating conditions. Any other use without the written consent of Condair, is considered as not conforming with the intended purpose and may lead to the Condair RO-E(+) pure water system becoming dangerous and will void any warranty.

The intended use also includes observing **all information contained in this operation manual as well as in the installation manual of the Condair RO-E(+) pure water system (in particular the safety instructions).**

2.3 Danger that may arise from the Condair RO-E(+) pure water system



DANGER! Risk of electric shock!

The Condair RO-E(+) pure water system is mains powered. Live parts may be exposed when the control compartment or the terminal box of the pump motor is/are open. Touching live parts may cause severe injury or danger to life.

Prevention: Before carrying out any work on the components of the Condair RO-E(+) pure water system take the system out of operation as described in [Section 5.3](#) and secure the system against inadvertent power-up.

Important: The frequency converter in the Condair RO-E(+) pure water system contains capacitors. These can remain charged with a potentially deadly voltage for a certain period of time after the Condair RO-E(+) pure water system has been disconnected from the power supply. Therefore, wait at least 10 minutes after disconnecting the power supply. Then make sure the appropriate contacts on the frequency converter and the terminals on the pump motor are free of voltage before starting any work on these components!



DANGER! Health risk because of inadequate hygiene!

Inadequately operated and/or poorly maintained pure water systems may endanger health.

Prevention: The Condair RO-E(+) pure water system must strictly be operated and maintained in accordance with this manual.



CAUTION!

Do not use oil, grease, glue, Teflon, silicone, O-ring lubrication, etc. when assembling pipes or hose connections. All of these products can lead to the growth of bacteria and thus pose health risks.

Only approved lubricant is: **Dishwashing liquid.**

Always wash your hands and wear clean disposable gloves while assembling parts in direct contact with water.

Do not remove dust protection caps on pipe and hose ends until just before assembly.

When fitting water filters, RO membranes, hoses and other components in direct contact with water, wash your hands and wear sterile disposable gloves or touch only the packing foil to keep the filter and RO membranes bacteria-free.



WARNING!

Water produced from a Condair RO-E(+) pure water system is very aggressive and can cause metals to corrode quickly. The Condair RO-E(+) pure water system should always be connected to piping / equipment suitable for handling reverse osmosis water.

2.4 Ensure safe operation

Observe all local safety standards

Observe all local safety standards regarding the handling of **mains-powered electrical and electronic devices**, and the design and handling of **low-pressure water systems**.

Preventing unsafe operation

If it is suspected that **safe operation is no longer possible**, the Condair RO-E(+) pure water system should immediately **be shut down and secured against accidental power-up according to [Section 5.3](#)**. This can be the case under the following circumstances:

- if the Condair RO-E(+) pure water system or other system components are damaged
- if the electrical installations are damaged
- if the Condair RO-E(+) pure water system is no longer operating correctly
- if connections and/or piping are not sealed

All persons working with the Condair RO-E(+) pure water system must report any alterations to the system that may affect safety to the owner without delay.

Prohibited modifications to the unit

No modifications must be undertaken on the Condair RO-E(+) pure water system without the express written consent of Condair.

For the replacement of defective components use exclusively **original accessories and spare parts** available from your Condair representative.

Recommended fire extinguisher system:

Fire extinguishers must be suitable for tackling fires in electrical installations to 1000 V. Extinguishing agents can be foam, water, powder or CO₂.

2.5 Hygiene

Please observe the local health and safety executive's technical guidance on the control of Legionellosis in water systems.

The operator is responsible for ensuring that the water system complies with local regulations, bylaws and guidelines (such as the HSE ACoP L8, VDI 6022, ISO 22000, HACCP or equivalent). If inadequately maintained, the Condair RO-E(+) pure water system, can support the growth of microorganisms, including the bacterium that causes Legionnaires' disease.

The Condair RO-E(+) pure water system is produced according to best hygiene standards, which means that we have considered all aspects of this equipment to reduce the risk of Legionnaires' disease and other similar conditions. However, the operator is responsible for ensuring that the operation and maintenance work on the equipment is performed in a manner, ensuring that the system stays clean!

Any risks or hazards relating to the system, including during installation and maintenance, should be identified by a competent health and safety representative who is responsible for introducing effective control measures.

DANGER!

The Condair RO-E(+) pure water system must be operated and maintained in accordance with this manual. Failure to do so could result in contamination that might cause Legionnaires' disease, which can be fatal.

WARNING!

To prevent water stagnation and microbial contamination, the power supply to the Condair RO-E(+) pure water system must be left switched on. If the system is switched off for more than 48 hours, the pipe work and system must be disinfected by a Condair service technician, and a full risk assessment in case of use of a Condair adiabatic humidifier must be undertaken to ensure safe operation.

WARNING!

Poorly maintained Condair RO-E(+) pure water system may be hazardous.

Prevention: Read, understand and follow maintenance guidelines to ensure your system stays safe.

2.5.1 Guidelines to ensure your system stays clean and prevent the growth of Legionella

- Carry out a risk assessment of the water system using a competent person and implement an appropriate monitoring and control program.
- Initiate procedures for checking the system, cleaning tanks, changing filters, disinfection etc.
- Enter into a service contract that suits you or your company.
- The Condair RO-E(+) pure water system must be connected to a clean, potable mains water supply.
- Stop the system if polluted drinking water is found in your area.
- Avoid water temperatures above 20 °C that favor the growth of microorganisms, including the Legionella bacterium. If the water temperature surpasses 20 °C contact your Condair representative if the Condair RO-E(+) pure water system is used in connection with a Condair adiabatic humidifier.
- To avoid water stagnation do not stop the system unless it is faulty or leaking.
- Have the Condair RO-E(+) pure water system be disinfected by a Condair service technician at least once a year and after every maintenance or repair. A complete system disinfection inclusive humidifier must be carried out by a Condair service technician if the Condair RO-E(+) pure water system has been turned off for more than 48 hours.
- Have water samples taken and tested for harmful bacteria at least once a year.
- Conduct follow-up measurements until the system is clean if bacteria have been detected in the system.

The Condair service team can help

Condair has expert technicians who can provide:

- Bacteriological troubleshooting on site
Note: Condair uses a quick method for measuring bacterial activity in the water: the approved and patented BactiQuant. Once the water sample has been taken, we can read the bacteriological quality of the water within 30 minutes, and disinfect the system if necessary.
Condair follows the guidelines in VDI 6022 for CFU counts in humidifiers. The CFU count in the humidification water must not exceed 150 CFU/ml, corresponding to a maximum BQ value of 40.
- Cleaning and disinfecting
- Preventive maintenance
- Repair and fault finding
- Training and guidance

Please contact your local Condair representative for further information about our services.

3 Product Overview

3.1 Product overview Condair RO-E pure water systems

3.1.1 Model overview Condair RO-E pure water systems

The Condair RO-E pure water system is designed for the production of **reverse osmosis water for Condair isothermal humidifiers** and is available in **4 models** with different maximum pure water output. All four models have the same housing and the same electrical parts.

All systems can be operated as **stand-alone systems** controlled via the external control unit (supplied with stand-alone systems). Together with the Condair RS steam humidifier, the Condair RO-E can also be operated as **integrated system**, controlled via the integrated control unit of the Condair RS.

	Model			
	RO-E 40	RO-E 100	RO-E 200	RO-E 300
Pure water output ¹⁾ at 10°C against 3 bar	61 l/hr	152 l/hr	303 l/hr	350 l/hr ²⁾
Pure water output ¹⁾ at 10°C against 1 bar	78 l/hr	183 l/hr	350 l/hr ²⁾	350 l/hr ²⁾
Pure water output ¹⁾ at 15°C against 3 bar	72 l/hr	180 l/hr	350 l/hr ²⁾	350 l/hr ²⁾
Pure water output ¹⁾ at 15°C against 1 bar	92 l/hr	218 l/hr	350 l/hr ²⁾	350 l/hr ²⁾
RO membrane type	1x 14"	1x 21"	2x 21"	3x 21"
Pressure tank	internal		external	
Nominal volume	25 l		112 l	
Usable volume at 5 bar	18 l		79 l	

¹⁾ Performance data valid at:

Water temperature	according to table
Tank back pressure	according to table
Pump pressure RO-E 40	10 bar
Pump pressure RO-E 100-300	12 bar
Inlet water quality	Softened water

Note: The pure water output rates are theoretically calculated values that may differ from reality. To avoid shortening the membrane lifespan, the purified water flow rate should not be set higher than specified for the respective Condair RO-E (e.g. RO-E 300 = approx. 300 l/hr).

²⁾ Maximum possible pure water output due to the pump performance.

RO-E 40

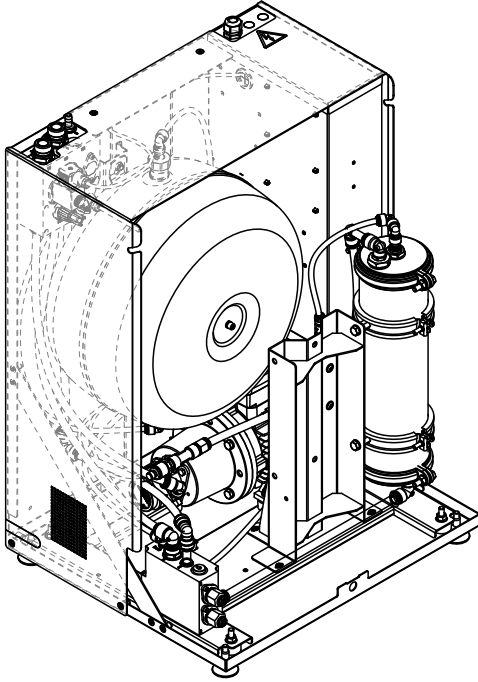

RO-E 100

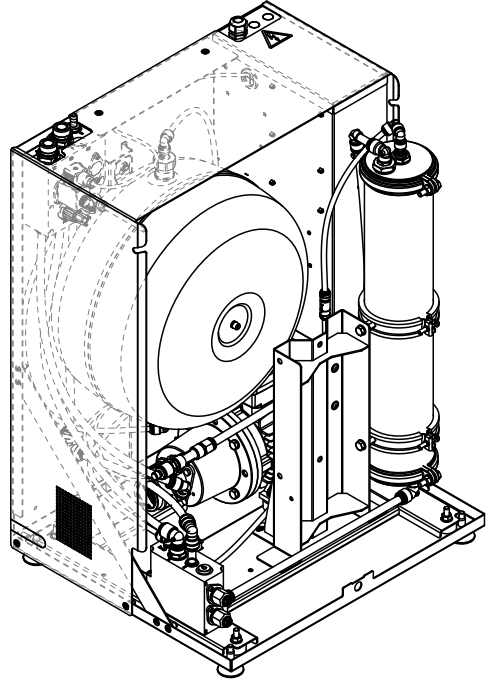

RO-E 200

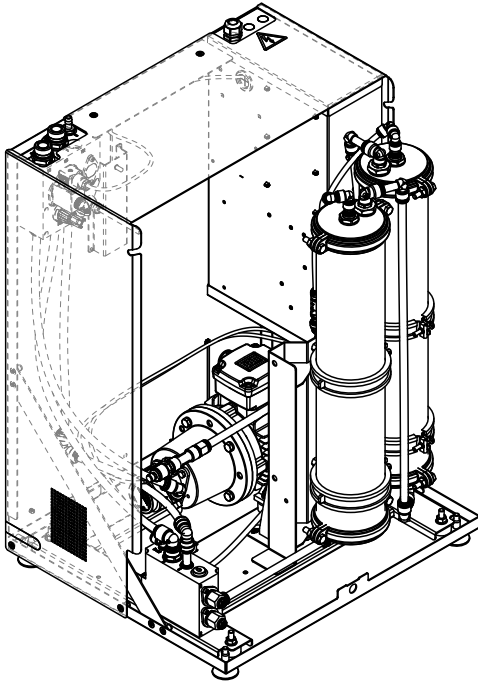

RO-E 300

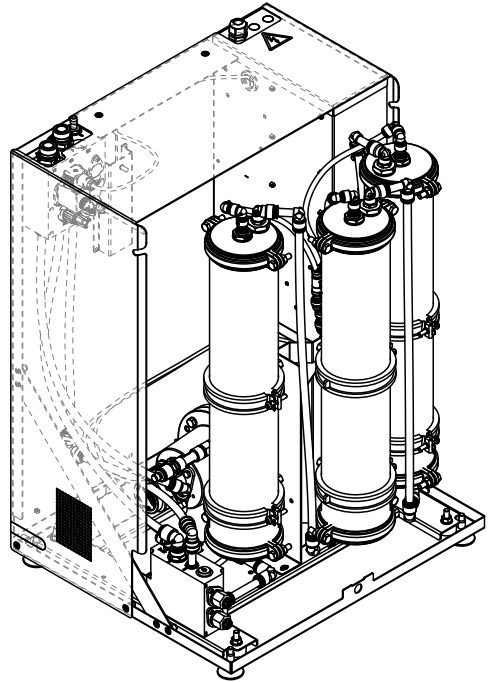

3.1.2 Condair RO-E construction

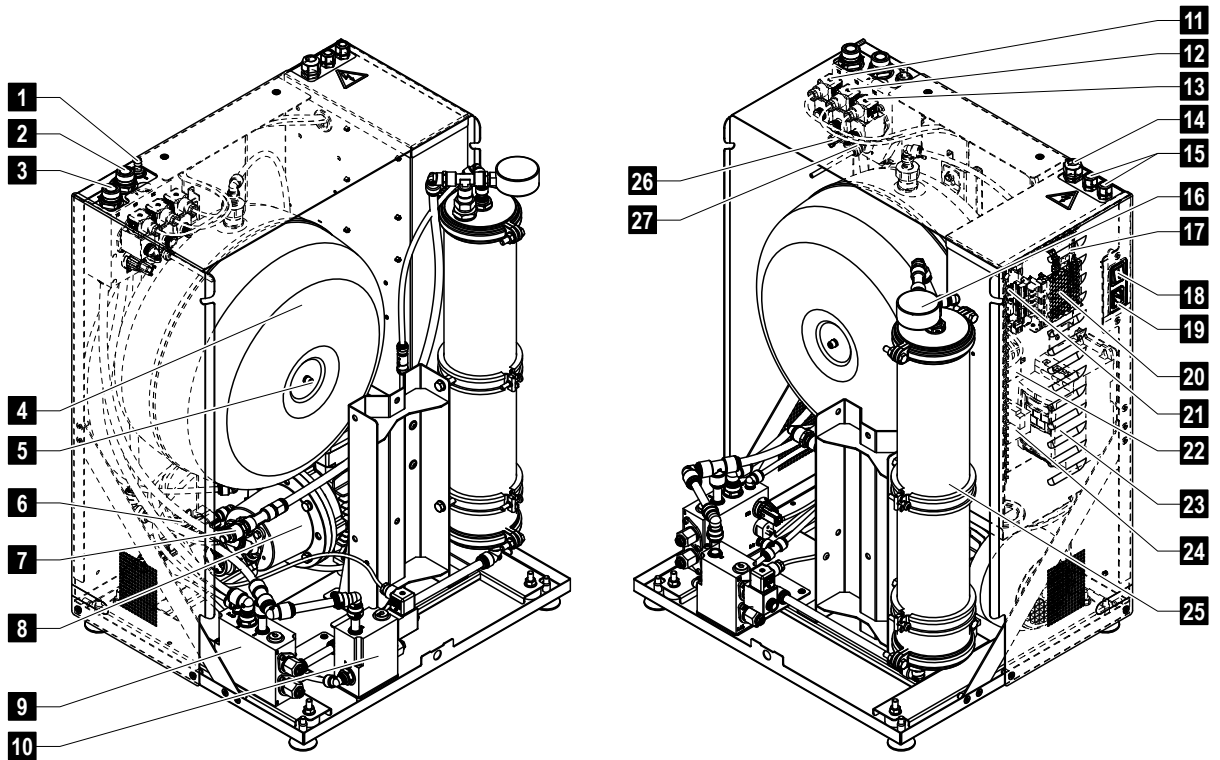

- | | |
|---|--|
| <ul style="list-style-type: none"> 1 Outlet connector drain water 2 Outlet connector reverse osmosis water 3 Inlet connector supply water 4 Internal pressure tank (RO-E 40 and RO-E 100 only) 5 Air pressure valve pressure tank 6 Volume flow measurement (Option VF) 7 Pressure sensor PS3 membrane pressure 8 Motor with pump 9 Logic block standard with: <ul style="list-style-type: none"> – Throttle valve recycle – Throttle valve drain water – Temperature and conductivity measurement (Option CTM) or conductivity measurement (Option CM) – Pressure sensor PS2 tank pressure 10 Logic block options with: <ul style="list-style-type: none"> – Concentrate valve Y16 (NC), Option CV – Throttle valve conductivity adjustment with check valve, Option CA 11 Inlet valve Y11 (NC) | <ul style="list-style-type: none"> 12 Outlet valve permeate Y13 (NO), Option OV 13 Drain valve Y12 (NO), Option DV 14 Cable gland for connecting the external control unit or the Condair RS steam humidifier 15 Additional cable glands (accessory) 16 Manometer membrane pressure, Option PPG 17 Connection Terminals 18 Unit switch 19 Mains supply socket 20 Internal power supply 21 Driver board RO-E(+) 22 Line filter 23 Frequency converter pump drive 24 Line choke 25 Membrane tube 26 Pressure sensor PS1 inlet pressure 27 Sampling tap |
|---|--|

Fig. 1: Construction Condair RO-E (figure shows Condair RO-E 100 with all options installed)

3.2 Product overview Condair RO-E+ pure water systems

3.2.1 Model overview Condair RO-E+ pure water systems

The Condair RO-E+ pure water system is designed for the production of **reverse osmosis water for Condair adiabatic humidifiers** and is available in **4 models** with different maximum pure water output. All four models have the same housing and the same electrical parts.

All systems can be operated as **stand-alone systems** controlled via the external control unit (supplied with stand-alone systems). Together with the Condair RS steam humidifier, the Condair RO-E+ can also be operated as **integrated system**, controlled via the integrated control unit of the Condair RS.

	Model			
	RO-E+ 40	RO-E+ 100	RO-E+ 200	RO-E+ 300
Pure water output ¹⁾ at 10°C against 3 bar	34 l/hr	90 l/hr	180 l/hr	270 l/hr
Pure water output ¹⁾ at 10°C against 1 bar	44 l/hr	108 l/hr	218 l/hr	325 l/hr
Pure water output ¹⁾ at 15°C against 3 bar	40 l/hr	107 l/hr	215 l/hr	320 l/hr
Pure water output ¹⁾ at 15°C against 1 bar	52 l/hr	130 l/hr	260 l/hr	350 l/hr ²⁾
RO membrane type	1x 14"	1x 21"	2x 21"	3x 21"
Nominal volume pressure tank	internal ³⁾		external ⁴⁾	
Usable volume pressure tank at 5 bar	25 l 18 l		140 l 102 l	

¹⁾ Performance data valid at:

Water temperature	according to table
Tank back pressure	according to table
Pump pressure RO-E+ 40	10 bar
Pump pressure RO-E+ 100-300	12 bar
Inlet water quality	Softened water

Note: The pure water output rates are theoretically calculated values that may differ from reality. To avoid shortening the membrane lifespan, the purified water flow rate should not be set higher than specified for the respective Condair RO-E (e.g. RO-E+ 300 = approx. 300 l/hr).

²⁾ Maximum possible pure water output due to the pump performance.

³⁾ Models with internal pressure tank. Up to 3 **additional** external pressure tanks available as accessory (available as accessory, see [Section 3.7 in the Condair RO-E\(+\) installation manual \(2613275\)](#)) can be connected.

⁴⁾ Up to 3 external pressure tanks available as accessory (available as accessory, see [Section 3.7 in the Condair RO-E\(+\) installation manual \(2613275\)](#)) can be connected.

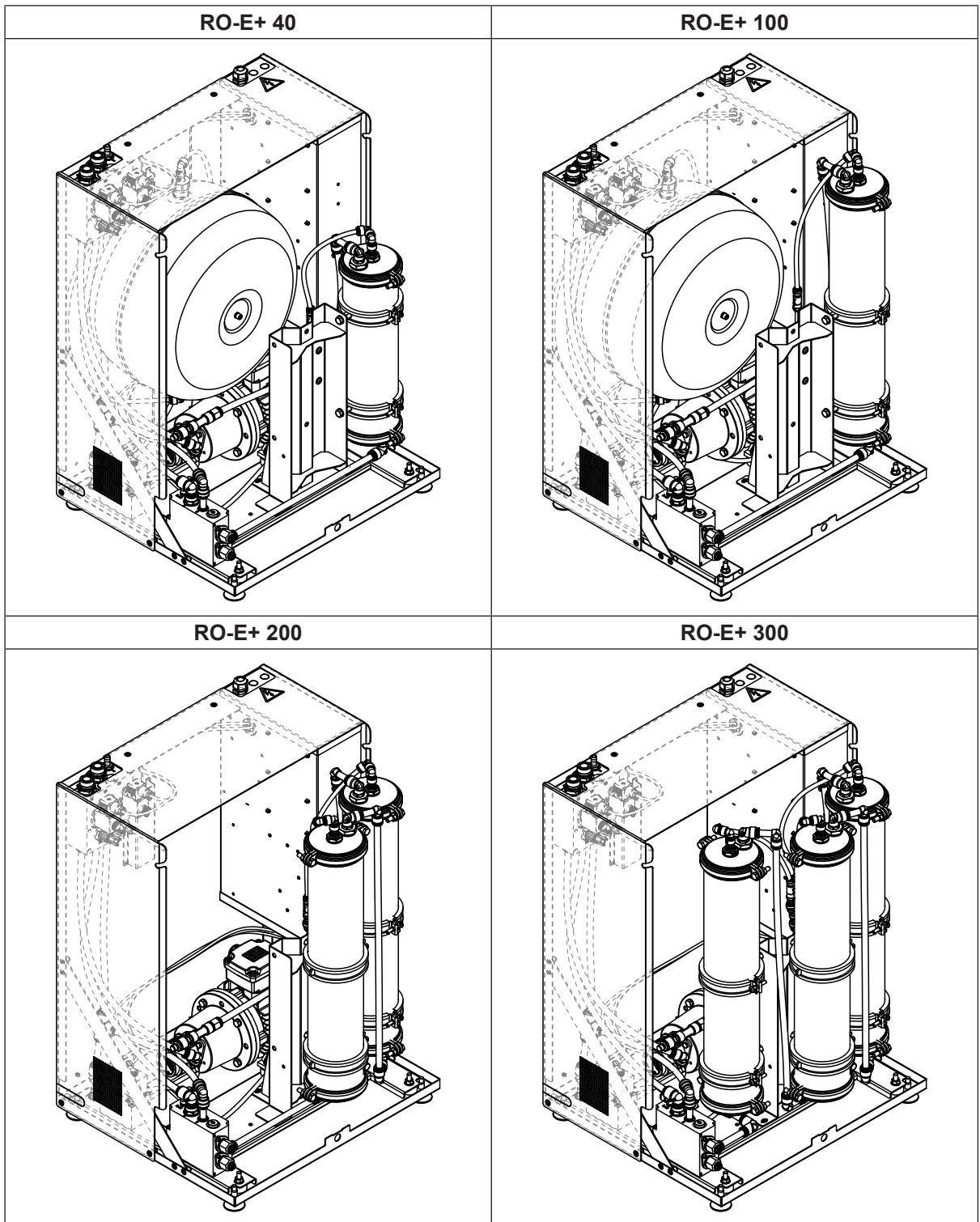

3.2.2 Condair RO-E+ construction

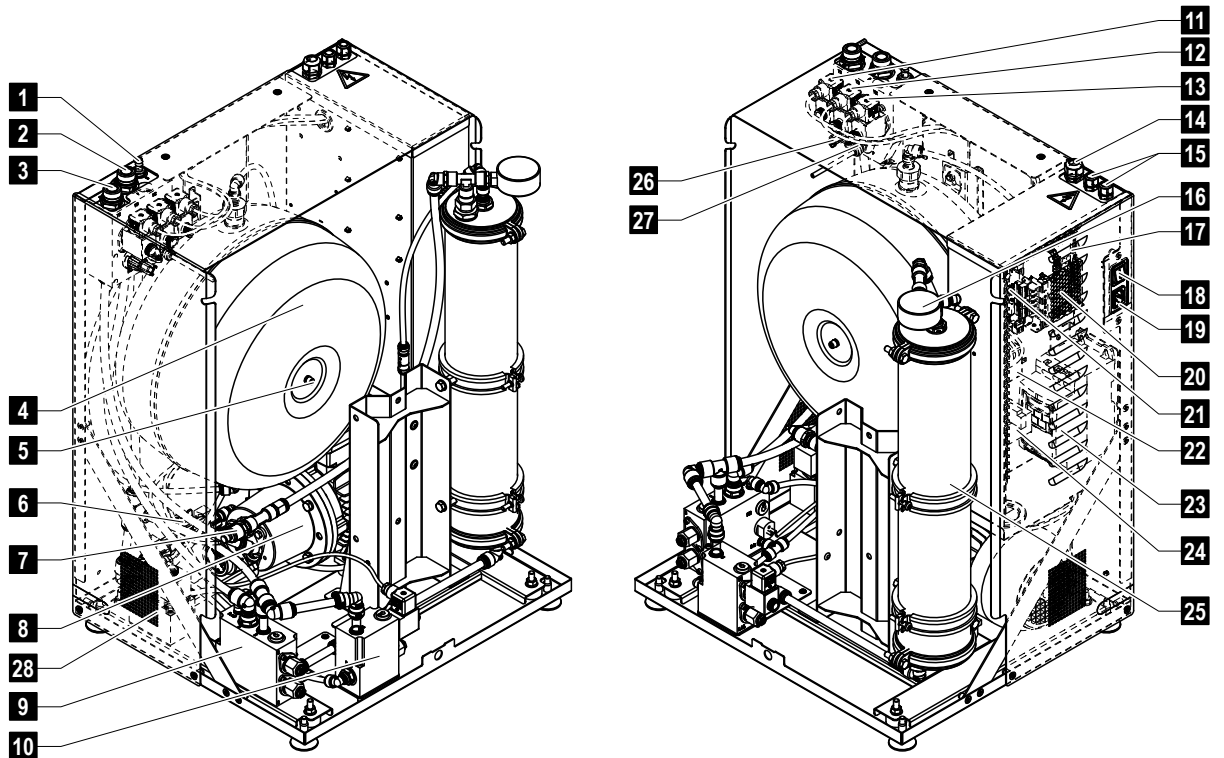

- | | | | |
|----|---|----|--|
| 1 | Outlet connector drain water | 15 | Additional cable glands (accessory) |
| 2 | Outlet connector reverse osmosis water | 16 | Manometer membrane pressure, Option PPG |
| 3 | Inlet connector supply water | 17 | Connection Terminals |
| 4 | Internal pressure tank (RO-E+ 40 and RO-E+ 100 only) | 18 | Unit switch |
| 5 | Air pressure valve pressure tank | 19 | Mains supply socket |
| 6 | Volume flow measurement (Option VF) | 20 | Internal power supply |
| 7 | Pressure sensor PS3 membrane pressure | 21 | Driver board RO-E(+) |
| 8 | Motor with pump | 22 | Line filter |
| 9 | Logic block standard with: | 23 | Frequency converter pump drive |
| | – Throttle valve recyclate | 24 | Line choke |
| | – Throttle valve drain water | 25 | Membrane tube |
| | – Temperature and conductivity measurement (Option CTM) or conductivity measurement (Option CM) | 26 | Pressure sensor PS1 inlet pressure |
| 10 | Logic block options with: | 27 | Sampling tap |
| | – Concentrate valve Y16 (NC), Option CV | 28 | Logic block Y15 with: |
| 11 | Inlet valve Y11 (NC) | | – Permeate valve Y15 (NC) |
| 12 | Outlet valve permeate Y13 (NO), Option OV | | – Check valve permeate and check valve drain water |
| 13 | Drain valve Y12 (NO), Option DV | | – Pressure sensor PS2 tank pressure |
| 14 | Cable gland for connecting the external control unit or the Condair RS steam humidifier | | |

Fig. 2: Construction Condair RO-E (figure shows Condair RO-E+ 100 with all options installed)

3.3 Functional description Condair RO-E(+)

A reverse osmosis system demineralises the supplied water by filtration at a low energy consumption. The product of the system is "salt-free" water (also known as reverse osmosis water, pure water or permeate) and is up to 99% free of dissolved substances in the water and microorganisms, such as minerals and germs.

Reverse osmosis systems are used in pharmaceutical and food industry, heating and power plant engineering, as well as in air humidification. They are based on the economically favourable and continuous process of water filtration by reverse osmosis. The reverse osmosis (by osmosis - diffusion through a semi-permeable membrane) is a filtration at nanoscale level. It takes place at a differential pressure in the reverse osmosis membrane.

The membrane is a wrapped filter, which is flowed alongside by supply water. Filtered water flows under pressure through various membrane layers and is separated from the additives. The product (pure water) is collected in the center of the membrane (diaphragm). Dissolved or entrained substances of the supply water are carried further along the filter. The product is filtered, depending on supply water quality, up to 99%. In the concentrate minerals and other substances flow lengthwise through the membrane. The concentrate is passed partly into the drain and partly mixed with the supply water to reduce water consumption.

The pure water quality is usually controlled by a conductivity measurement of the product water. The lower the conductivity, the higher the electrical resistance and the purer the product water. Filtration quality depends on the particle size: gases due to their small molecular size pass through the membrane layers and increase the conductivity of the product. For sensitive applications the quality of the supply water and the product water must be checked and optionally be periodically monitored.

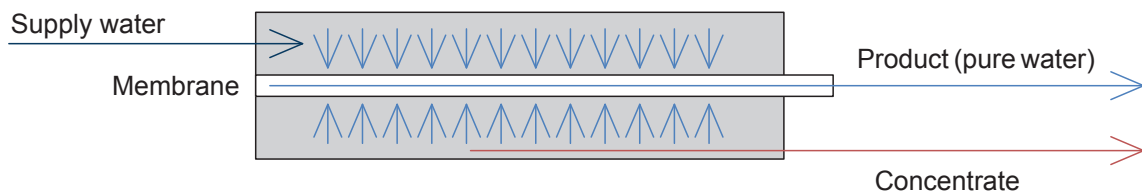

Fig. 3: Functional diagram of the reverse osmosis membrane

The Condair RO-E(+) pure water system is designed for demineralised water production. The system uses special "low-energy" reverse osmosis membranes that are especially efficient: the membranes permit under the listed supply water demands a particularly energy-saving water filtration at a desalination up to 99%.

The Condair RO-E(+) pure water system has a compact design, an internal pressure tank (RO-E(+) 40 and RO-E(+) 100 only), and a sampling tap for monitoring the product (permeate). Up to three external pressure tanks can be connected to all models. The Condair RO-E(+) pure water system is intended for rapid "movable" installations and is bound only by hoses. The external control unit (with stand-alone systems) or the control unit of the Condair RS steam humidifier (with integrated systems) allows an accurate and simple control and offers numerous setting and monitoring functions.

3.4 System overview

Principal system layout Condair RO-E(+) stand-alone systems

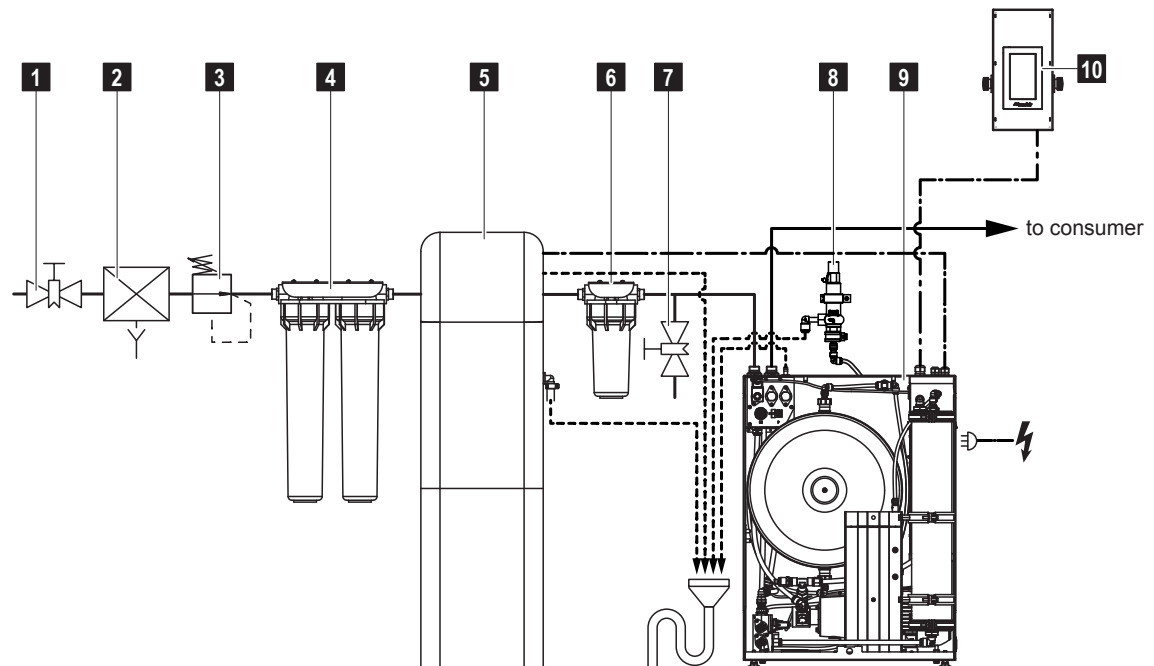

- | | |
|---|---|
| 1 Shut-off valve (mandatory, by others) | 6 Filter 5 µm (mandatory if water softener is used, available as accessory) |
| 2 Backflow preventer (where mandatory by local regulations, by others) | 7 Sampling tap (optional, recommended for taking water samples) |
| 3 Pressure reduction valve (mandatory for water supply pressure >6 bar, available as accessory) | 8 Safety valve pressure tank (optional, mandatory for CE certified systems) |
| 4 Single, double or tripple pre-filter (optional but recommended, double or tripple filter mandatory for occasionally chlorinated supply water, available as accessory) | 9 Condair RO-E(+) |
| 5 Water softener (optional, available as accessory) | 10 External control unit |

Fig. 4: Principal system layout Condair RO-E(+) stand-alone systems (figure shows RO-E 100 with internal pressure tank)

Principal system layout Condair RO-E(+) integrated systems with Condair RS steam humidifier

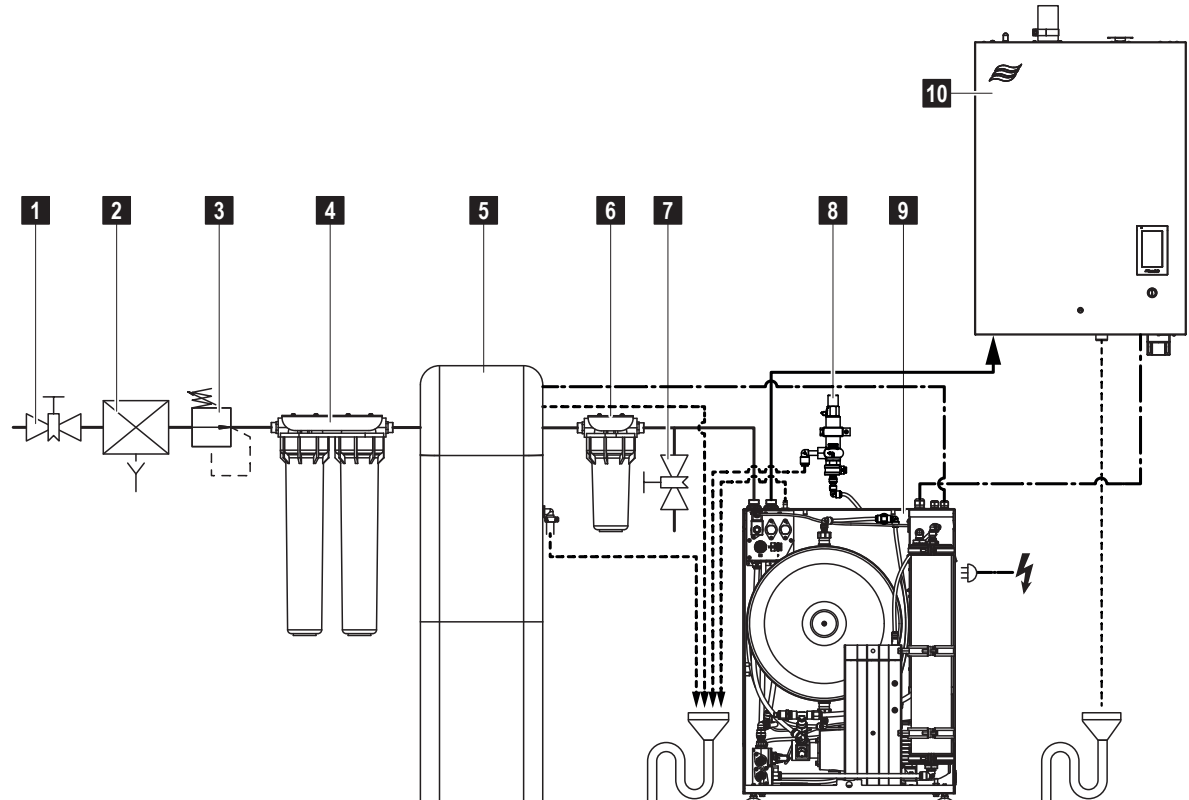

- | | |
|---|---|
| 1 Shut-off valve (mandatory, by others) | 6 Filter 5 µm (mandatory if water softener is used, available as accessory) |
| 2 Backflow preventer (where mandatory by local regulations, by others) | 7 Sampling tap (optional, recommended for taking water samples) |
| 3 Pressure reduction valve (mandatory for water supply pressure >6 bar, available as accessory) | 8 Safety valve pressure tank (optional, mandatory for CE certified systems) |
| 4 Single, double or tripple pre-filter (optional but recommended, double or tripple filter mandatory for occasionally chlorinated supply water, available as accessory) | 9 Condair RO-E(+) |
| 5 Water softener (optional, available as accessory) | 10 Condair RS steam humidifier |

Fig. 5: Principal system layout Condair RO-E(+) integrated systems (figure shows RO-E 100 with internal pressure tank and Condair RS steam humidifier)

4 Initial commissioning of the RO-E(+)

4.1 Requirements

For initial commissioning, it is assumed that the Condair RO-E(+) pure water system and all associated system components are correctly installed and connected and that the installations have been checked for correct execution.

The initial commissioning, testing and configuration of the Condair RO-E(+) pure water system may only be carried out by a Condair service technician or a service personnel trained and authorized by Condair.

4.2 Quick test of electrical installation

Check the electrical installation as follows

- If applicable: Is a residual current device with the correct specifications installed in the power supply line (installation recommended, for specifications see installation manual for the Condair RO-E(+) pure water system).
- Is the power supply correctly fused (for specifications see the installation manual for the Condair RO-E(+) pure water system).

4.3 First steps after the Condair RO-E(+) pure water system has been installed

1. Ensure that the water supply to the Condair RO-E(+) pure water system is closed and that the Condair RO-E(+) pure water system is disconnected from the power supply (power cable unplugged or power circuit breaker turned off).
2. Install the correct membrane(s) into the membrane tube(s). Follow the instructions in [Section 7.4.1.2](#).
Important: Do not switch on the Condair RO-E(+) pure water system yet.
3. Install the correct filter cartridges into the pre-filters in the water supply line. Refer to the instructions in the separate manual for the pre-filter(s) you are using.
4. Start up the optional water softener. Follow the instructions in the separate installation and operating manual for the respective water softener.

4.4 Configuration of the control software

To configure the IC2 control software, the water supply to the Condair RO-E(+) pure water system must not yet be open! Ensure that the shut-off valve in the water supply line is still closed.

1. Condair RO-E(+) pure water systems with mains plug connection: Check whether the device voltage of the Condair RO-E(+) pure water system (see type plate) matches the mains voltage of the socket.
Condair RO-E(+) pure water systems with fixed mains connection: Switch on the electrical isolator in the power supply line.
2. Switch on the unit switch on the Condair RO-E(+) pure water system and the Condair RS steam humidifier (if applicable).

The external control unit (standalone systems) or the control of the Condair RS steam humidifier (integrated systems) performs an automatic system test (initialization). Since the water supply is interrupted, the error message "W22/E22 - No Water" is displayed.

The Condair RO-E(+) pure water system is pre-configured ex factory. However the following settings must be configured in the control software on the external control unit or Condair RS steam humidifier. A detailed description of the setting parameters can be found in [Section 5](#).

- General settings (path: Menu > Password: 8808 > General):
 - Language [12], Units [19], Actual Date [10042], Actual Time [10043], Date Format [4], Clock Format [20], Daylight Saving [5]
- In the "Help" menu:
 - Check contact data

Note: If the Condair RO-E(+) pure water system is purchased together with a Condair RS steam humidifier as an integrated system, the operating mode must be set accordingly in the Service level of the Condair RS steam humidifier's control software.

If the Condair RO-E(+) pure water system is purchased as a retrofit for the operation with a Condair RS steam humidifier, please contact your local Condair representative, for a full system integration of the Condair RS steam humidifier and Condair RO-E(+) pure water system.

5 Operation

Important: The Condair RO-E(+) pure water system may only be put into operation by the system operator or a person authorized by the owner after the acceptance test has been carried out during initial commissioning by Condair customer service or a trained and Condair-authorized service technician. Furthermore, the system operator must have received instruction from Condair on how to operate the system.

Once initial commissioning and training in the operation of the unit is complete, the system owner must ensure that the system is operated only by trained personnel. This is an integral part of the Condair product warranty conditions and non-compliance will void the product warranty.

5.1 Start-up sequence for daily operation

The following description outlines the start-up procedure after an interruption of operation (e.g. after servicing the Condair RO-E(+) pure water system). It is assumed that first-time commissioning has been carried out properly by Condair Customer Service and the Condair RO-E(+) pure water system has been configured accordingly.

1. Examine the Condair RO-E(+) pure water system and the installations for possible damage.



DANGER!

Systems with damaged components or installations may present danger to human life or cause severe damage to material assets.

Therefore: Systems with damaged components and/or systems with damaged or faulty installations must not be operated.

2. Ensure all covers of the different system components are closed.
3. Open all shut-off valves in the supply water line and the pure water line.
4. Plug in the power supply adapter to the water softener (if applicable).
Note: Regarding the operation and configuration of the water softener control unit please refer to the separate operation manual of the water softener.
5. Plug in the power supply cable on the Condair RO-E(+) pure water system (devices with a mains socket) or switch on the power supply via the external electrical isolator (hardwired devices).
6. Switch on the unit switch on Condair RO-E(+) pure water system and on the Condair RS steam humidifier (if applicable).

The external control unit (standalone systems) or the Condair RS steam humidifier, respectively carry out an automatic system test (initializing). a fault is detected during the system test, a warning or error is displayed in the "device and error status field" on the home screen.

If the initialization is successful, the Condair RO-E(+) pure water system starts-up automatically and fills the pressure tank. As soon as the preset maximum pressure in the pressure tank is reached, the pump inside the Condair RO-E(+) pure water system is stopped.

If the water pressure in the pressure tank drops below the set minimum pressure the pump starts again and refills the pressure tank to the preset maximum pressure.

5.2 Notes on operation

5.2.1 Inspections during operation

Interval	Work to be carried out
Every 2 days	<p>Check salt level of the water softener. Refill salt if necessary according to the instructions in the separate operating manual of the water softener.</p> <p>Always use residue-free tablet salt certified to the DIN EN 973 Typ A standard (not rock salt, etc.)</p> <p>If no salt is being consumed, immediately inform Condair Customer Service!</p>
Weekly	<p>During operation the following checks must be performed on the Condair RO-E(+) pure water system:</p> <ul style="list-style-type: none">• check the system components and water installation for any leakage.• check the Condair RO-E(+) pure water system for any damage.• check the electric installation for any damage.• check the display of the external control unit or the Condair RS steam humidifier for any warning or error indication. <p>If the inspection reveals any irregularities (e.g. leakages, error indication) or any damaged components take the Condair RO-E(+) pure water system out of operation as described in Section 5.3. Then, contact your Condair representative.</p>

Monthly

Check the air pressure of the bladder inside the pressure tank. Proceed as follows:

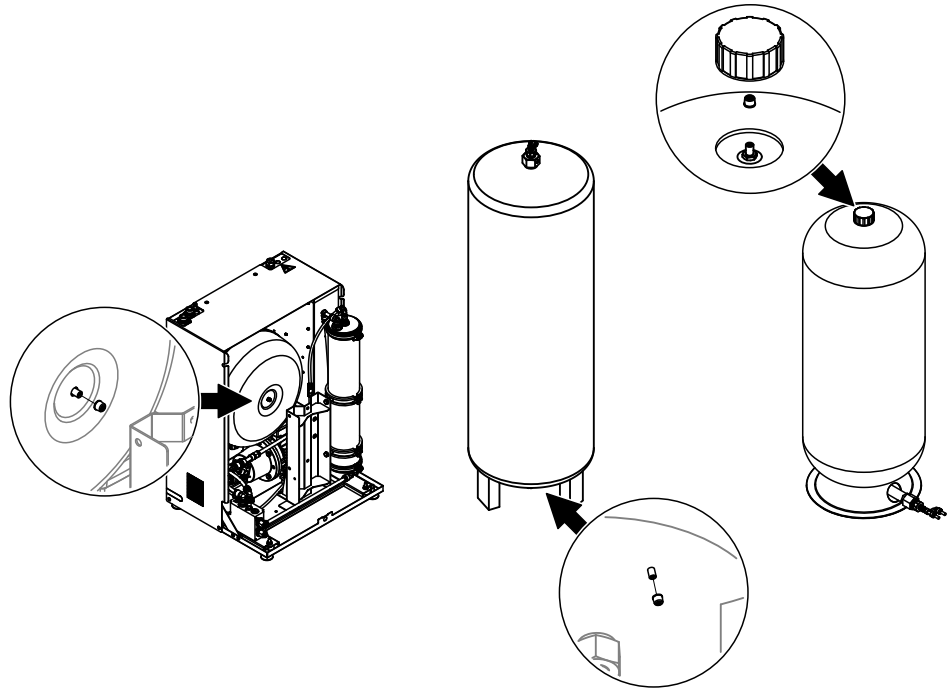

1. Close shut-off valve in the supply water line. Then completely drain the system by switching off the Condair RO-E(+) pure water system using the device switch.
2. Applies for Condair RO-E(+) 40 and RO-E(+) 100 with optional unit cover only: Unlock the retaining screw on the bottom of the unit cover of the Condair RO-E pure water system, then remove the unit cover.
3. Applies only to external pressure tank for Condair RO-E 200/300: Remove the cover cap on top of the pressure tank.
4. Remove the screw cap on the air valve at the front of the internal pressure tank or at the bottom or the top of the external pressure tank.
5. Check air pressure inside the pressure tank using a tyre pressure gauge. **The pressure must be between 0.5 to 0.8 bar.** Adjust pressure if necessary using a hand air pump.
6. Reassemble in reverse order and switch on Condair RO-E(+) pure water system.

5.2.2 Flushing of the internal water supply system and the membrane(s)

Note: If an error message is active flushing of the internal water supply system and the membrane(s) is not possible.

To perform a flushing of the internal water supply system and the membrane(s), proceed as follows:
Note: The following displays show the steps to initiate a flushing of the water supply system via the control software of the external control unit (stand alone system). The sequence via the control software of a Condair RS steam humidifier (integrated system) is identically only the content of the displays is slightly different.

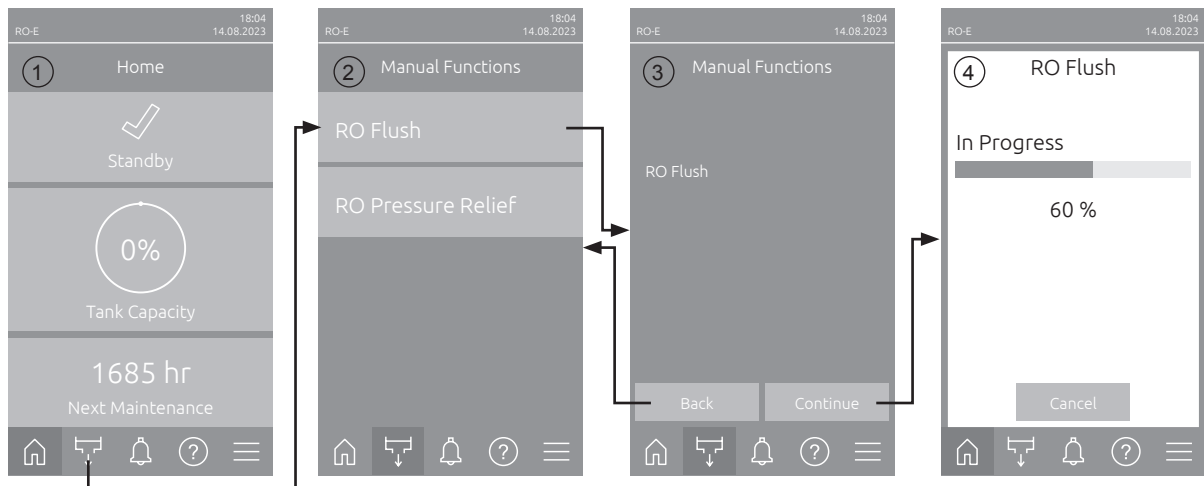

1. Press on the **<Manual Functions>** button in the home screen (1).
2. The "Manual Functions" menu (2) appears. Here, press on the **<RO Flush>** button.
3. The flushing confirmation display appears. Here, press on the **<Continue>** button to start the flushing of the water supply system.
4. The flushing progress display appears (4) and shows the current status of the flushing cycle. After flushing cycle has finished the home screen is shown again and the system continues to operate in normal operating mode.

In order to stop the flushing cycle, press the **<Cancel>** button in the flushing progress window. The flushing cycle is stopped, and the home screen is shown again. The system continues to operate in normal operating mode.

5.2.3 Performing a pressure relief of the Condair RO-E(+) pure water system

With the "RO Pressure Relief" function, the pressure in the Condair RO-E(+) pure water system can be relieved and the pressure tank emptied. If you additionally close the shut-off valve in the inlet line to the Condair RO-E(+) pure water system before carrying out the pressure relief, the system remains depressurized after the pressure relief, otherwise the pressure tank is automatically refilled and the system pressurized as soon as demand is present.

Note: If an error message is active a pressure relief of the Condair RO-E(+) pure water system is not possible.

To relieve the pressure in the Condair RO-E(+) pure water system (including the pressure tank), proceed as follows:

Note: The following displays show the steps to initiate a pressure relief of the Condair RO-E(+) system via the control software of the external control unit (stand alone system). The sequence via the control software of a Condair RS steam humidifier is identically only the content of the displays is slightly different.

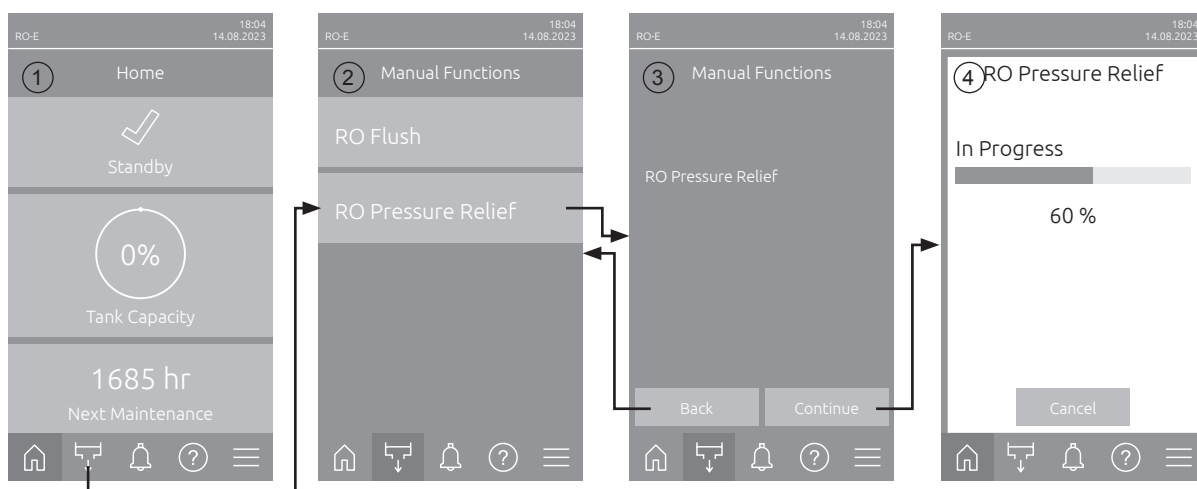

1. Close the shut-off valve in the supply water line to the Condair RO-E(+) pure water system if you do not want the system to be refilled and pressurized after pressure relief.
2. Press on the **<Manual Functions>** button in the home screen (1).
3. The "Manual Functions" menu (2) appears. Here, press on the **<RO Pressure Relief>** button.
4. The "RO Pressure Relief" confirmation display appears (3). Here, press on the **<Continue>** button to start the pressure relief of the Condair RO-E(+) pure water system.
5. The pressure relief progress display appears (4) and shows the current status of the pressure relief cycle. After pressure relief cycle has finished the home screen is shown again.

In order to stop the pressure relief cycle, press the **<Cancel>** button in the pressure relief progress window. The pressure relief cycle is stopped, and the home screen is shown again. The unit returns to normal operating mode.

5.3 Shut-down the system

Important! For reasons of hygiene, we recommend that the Condair RO-E(+) pure water system should be left switched on and the water supply should be left open even if no RO water is needed at the moment. With the system switched on and the water supply left open, the water circuit is flushed at regular intervals (every 24 hours) and hence the build-up of germs is opposed due to water stagnation in the system.

If you have to shut-down the Condair RO-E(+) pure water system (e.g. for maintenance purpose), perform the following steps:

1. Close the shut-off valve in the supply water line.
2. Switch off the Condair RO-E(+) pure water system via the unit switch.
3. Disconnect the Condair RO-E(+) pure water system and the water softener from the mains supply by unplugging the corresponding mains supply cable.



WARNING!

If the Condair RO-E(+) pure water system is shut-down for more than 24 hours, there is a risk of build-up of germs due to water stagnation in the system, since the automatic system flushing function (every 24 hours) is inactive. Please **always** inform Condair Customer Service before recommissioning the system after a prolonged shut-down.

6 Operating the Condair RO-E(+) control software

6.1 Home screen

After switching on the control unit and the automatic system test the control unit is in **normal operating** mode and the **home screen** is shown.

Note: The appearance of the home screen depends on the current device and error status and the configuration of the humidity control of the system. It can deviate from the display shown below.

The home screen is structured as follows:

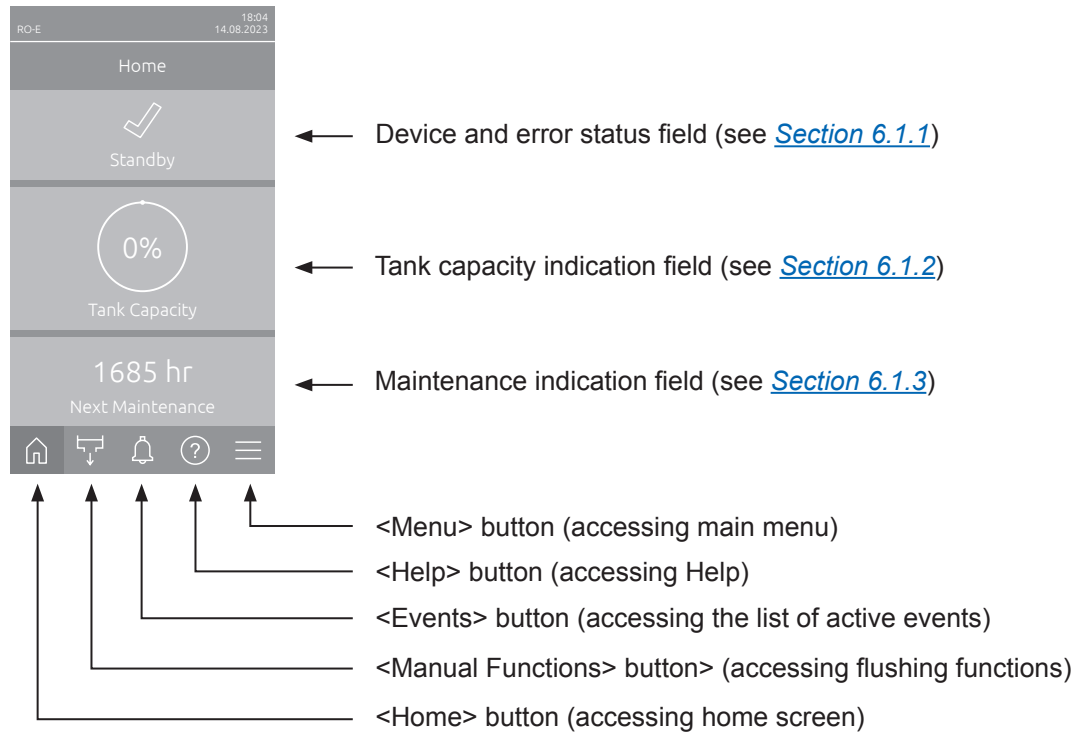
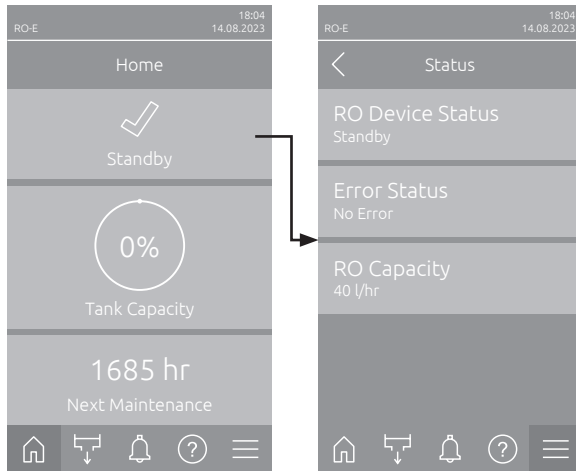

Fig. 6: Home screen

6.1.1 Device and error status indication field

If you press the device and error status field in the home screen, a window appears with further information on the device and error status (only for standalone systems).



- **RO Device Status:** Shows the current device status.
- **Error Status:** Shows the current error status ("No Error", "Warning" or "Error").
- **RO Capacity:** Shows the maximum capacity of the Condair RO-E(+) pure water system in l/hr.

The following error status symbols may be shown:

Error status symbol	Description
✓	The Condair RO-E(+) pure water system works perfectly.
!	A malfunction with the status "Warning" has occurred.
✗	A malfunction with the status "Error" has occurred. Depending on the error, the operation of the Condair RO-E(+) pure water system is stopped, or it continues to work to a limited extent.

The following device status indications may appear:

Device status	Description
Initializing	The control is initializing.
Stopped	The Condair RO-E(+) pure water system was stopped due to a malfunction that makes it impossible to continue operation.
Holding	The RO pressure tank is full.
Filling	The Condair RO-E(+) pure water system pumps permeate into the RO pressure tank.
Standby	The Condair RO-E(+) pure water system is in standby mode.
Flushing	The Condair RO-E(+) pure water system performs a complete system flush or a flushing of the water supply. During the complete system flushing, the RO pressure tank is emptied and then refilled. During the complete system flushing, permeate is directed to the drain instead of to the RO pressure tank until the specified reverse osmosis water quality is reached.
Draining	The water system of the Condair RO-E(+) pure water system is emptied.

6.1.2 Tank capacity indication field

If you press the tank capacity indication field in the home screen, a window appears with information about the pressure of the reverse osmosis tank (only for standalone systems).

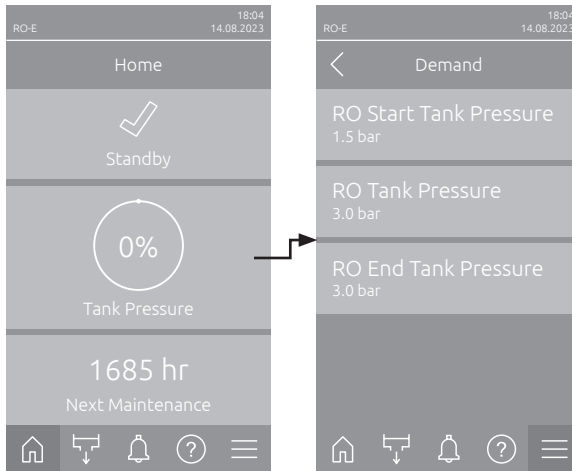

- **RO Start Tank Pressure:** Shows the tank pressure in bar at which the pump will start filling the tank again with RO water.
- **RO Tank Pressure:** Shows the current pressure in the RO tank in bar.
- **RO End Tank Pressure:** Shows the tank pressure in bar at which the tank is full and the pump stops filling the tank.

6.1.3 Maintenance indication field

If you press the Maintenance indication field in the home screen, a window appears with further information on maintenance.

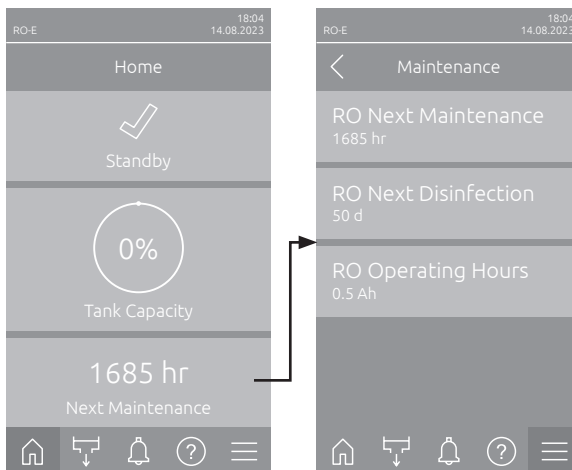

- **RO Next Maintenance:** Shows the remaining time in hours until the next maintenance is due.
- **RO Next Disinfection:** Shows the remaining time in days until the next disinfection is due. Note: Only appears if the setting "RO Disinfection Mode" has been activated in the Service level of the control software.
- **RO Operating Hours:** Shows the number of operating hours since initial commissioning.

6.2 Information functions in the "Help" Menu

6.2.1 Accessing the "Help" menu

Press the <Help> button in the home screen. The help menu with the contact details appears.

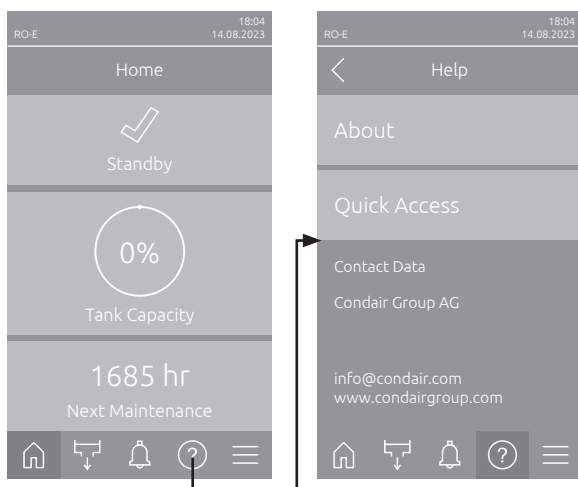

6.2.2 Query operating states in the "About" submenu



*Continued on
next page*

- **RO Type:** Device type ("RO-E"= for isothermal applications or "RO-E+"= for adiabatic applications).
- **RO Capacity:** Set RO capacity in l/hr.
- **RFI Type:** Shows whether the optional remote operating and fault indication board is installed and activated ("Yes") or not ("No").
- **Software Version:** Actual software versions of the control board ("Device FW Version" and "Bootloader FW Version") and driver boards ("RO-E Board", "RO-E Condu. Board" and "RFI Board").
- **Serial Number:** Serial number of the Condair RO-E pure water system.
- **RO Inlet Pressure:** Actual inlet pressure (measured by pressure sensor PS1) at the water supply inlet of the Condair RO-E in bar.
- **RO Tank Pressure:** Actual pressure in the RO tank (measured by pressure sensor PS2) in bar.
- **RO Membrane Pressure:** Actual RO membrane inlet pressure (measured by pressure sensor PS3) in bar.
Note: This info field appears only if the pressure sensor PS3 is installed.
- **RO Permeate Conductivity:** Actual conductivity of the permeate water in µS/cm.
Note: This info field appears only if the "Conductivity measuring" - option CM or "Conductivity and temperature measuring" - option CTM is installed.
- **RO Water Temperature:** Actual temperature of the permeate water in °C.
Note: This info field appears only if the "Conductivity and temperature measuring" - option CTM is installed.
- **RO Permeate Volume Flow:** Actual volume flow of the permeate water in l/hr.
Note: This info field appears only if the "RO Permeate Volume Flow" option is installed and activated in the Service level of the control software.
- **RO Start Tank Pressure:** Currently set tank starting pressure in bar at which the permeate pump starts and fills the tank.
- **RO End Tank Pressure:** Currently set final tank pressure in bar at which the permeate pump stops.
- **RO Inlet Valve:** Actual status of the inlet valve "Y11" (Open or Closed).
- **RO Outlet Valve:** Actual status of the outlet valve "Y13" (Open or Closed).
Note: This info field appears only if the "RO Outlet Valve" option is installed and activated in the Service level of the control software.
- **RO Drain Valve:** Actual status of the drain valve "Y12" (Open or Closed).
Note: This info field appears only if the "RO Drain Valve" option is installed and activated in the Service level of the control software.

RO Permeate Valve Closed
RO Concentrate Valve Closed
RO Flow Warn Limit 0 l/hr
RO FC Setpoint 0 rpm

- **RO Permeate Valve:** Actual status of the permeate valve Y15 (Open or Closed).
Note: This info field only appears if the "RO Type" setting in the Service level of the control software was set to "RO-E+".
- **RO Concentrate Valve:** Actual status of the concentrate valve Y16 (Open or Closed).
Note: This info field appears only if the "RO Concentrate Valve" option is installed and activated in the Service level of the control software.
- **RO Flow Warn Limit:** Currently set flow warning limit in l/hr.
Note: This info field appears only if the "RO Permeate Volume Flow" option is installed and activated in the Service level of the control software.
- **RO FC Setpoint:** Currently set setpoint speed on the frequency converter in rpm.

6.2.3 Quick access to setting parameters in the "Quick Access" submenu

Press the <Quick Access> button in the "Help" menu. Then enter the quick access number of the desired setting parameter. You will find this number in the top left corner in the setting window of the corresponding parameter. Confirm the entry and the setting dialog for the corresponding parameter appears.
Note: If the parameter is password protected, after entering the quick access number, the password "8808" must first be entered before the setting dialog for the parameter appears.

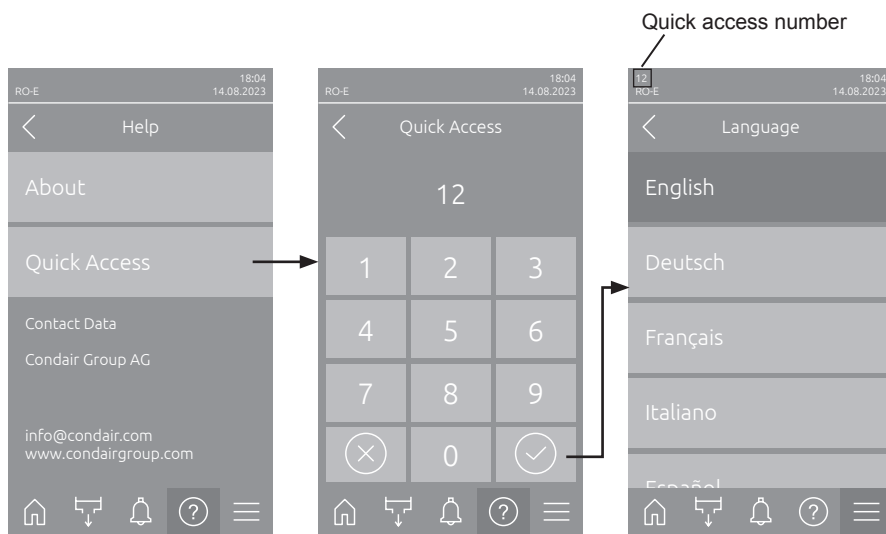

6.3 Configuration

6.3.1 Settings and features in the "General" submenu

6.3.1.1 Accessing the "General" submenu

Access the "General" submenu as shown below.

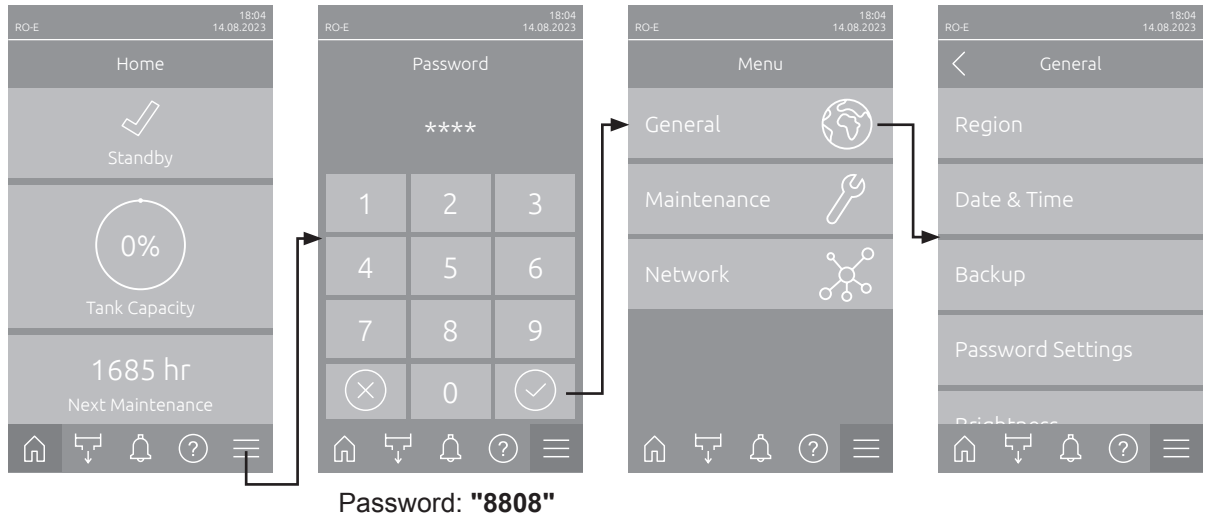

6.3.1.2 Determine language and system of units in the "Region" submenu



- **Language:** With this setting you determine the language.
Factory setting: **depending on the country**
Options: **different languages**
- **Units:** With this setting you determine the desired unit system.
Factory setting: **depending on the country**
Options: **Metric or Imperial**

6.3.1.3 Date and time settings in the "Date & Time" submenu

Note: The date and time must be entered correctly, as these are used for the entries in the malfunctions and maintenance history list.



- **Date:** With this setting you determine the current date in the set format ("MM/DD/YYYY" or "DD.MM.YYYY").
Factory setting: **01/01/2020**
- **Time:** With this setting you set the current hour of the day in the set time format ("12H" or "24H").
Factory setting: **12:00**
- **Date Format:** With this setting you determine the desired date format.
Factory setting: **DD.MM.YYYY**
Options: **DD.MM.YYYY** or **MM/DD/YYYY**
- **Clock Format:** With this setting you determine the desired time format.
Factory setting: **24H**
Options: **24H** (24 hours, display 13:35) or **12H** (12 hours, display: 01:35 PM)
- **Daylight Saving:** With this setting you determine the daylight saving time summer time / winter time).
Factory setting: **Wintertime**
Options: **Summertime** or **Wintertime**

6.3.1.4 Read in parameter settings in the "Backup" submenu

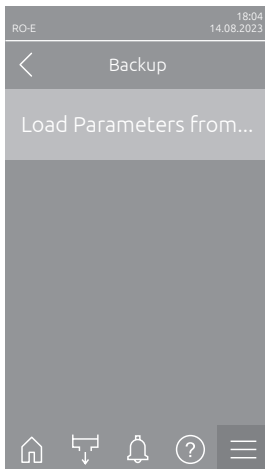

- **Load Parameters from USB:** With this function you can read in parameter settings that were previously saved on a FAT32 formatted USB stick. To do this, the USB stick with the parameter settings must be inserted into the USB interface on the control board. After pressing the selection field, a confirmation dialog appears in which you have to confirm the loading of the parameter settings again.

6.3.1.5 Activate/Deactivate password protection in the "Password Settings" submenu

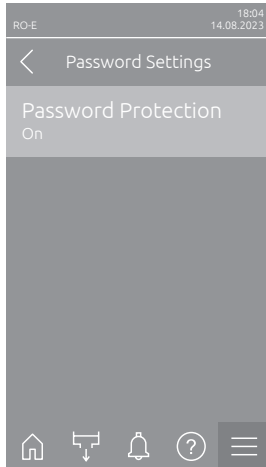

- **Password Protection:** With this function you can protect the access to the main menu with the user password "8808" against unauthorized access ("On") or not ("Off").
Factory setting: **On**
Options: **Off or On**

6.3.1.6 Set the brightness of the touchscreen and the LED in the "Brightness" submenu

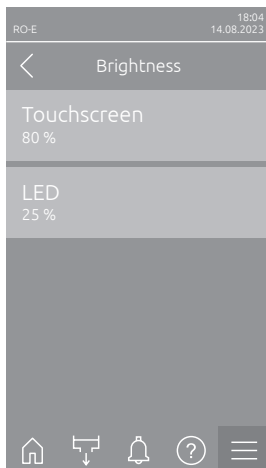

- **Touchscreen:** With this setting you determine the desired value for the display brightness.
Factory setting: **80 %**
Settings range: **15 ... 100 %**
- **LED:** With this setting you determine the desired value for the brightness of the status LED.
Factory setting: **25 %**
Settings range: **25 ... 100 %**

6.3.2 Settings and features in the "Maintenance" submenu

6.3.2.1 Accessing the "Maintenance" submenu

Access the "Maintenance" submenu as shown below.

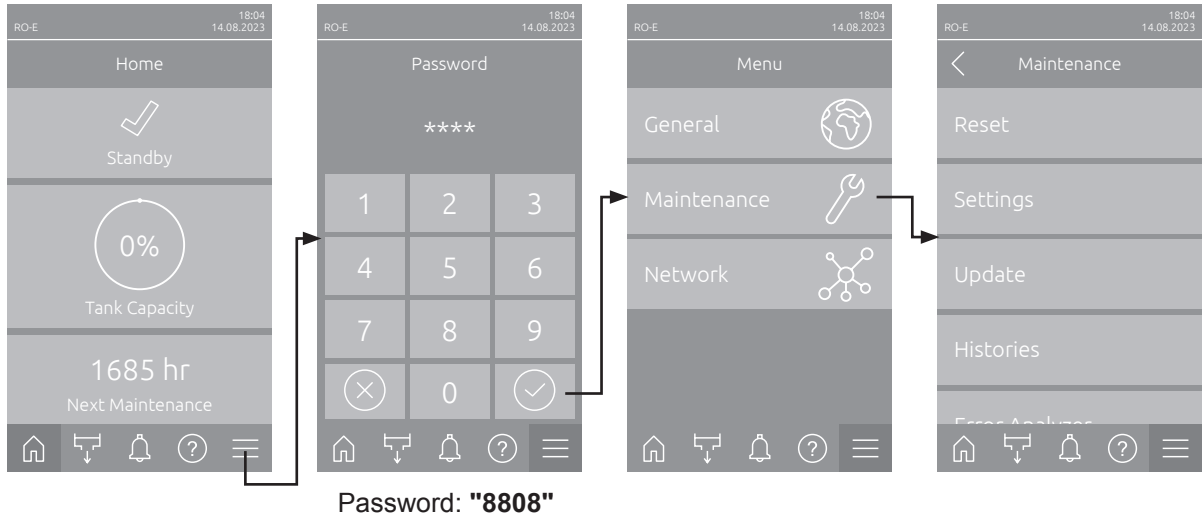

6.3.2.2 Reset functions in the "Reset" submenu

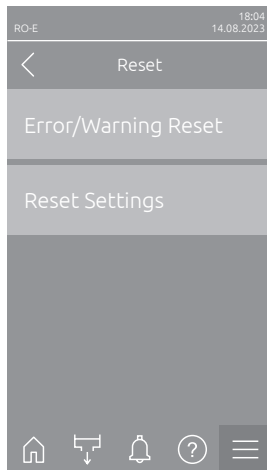

- **Error/Warning Reset:** With this function you can reset pending errors/warnings after eliminating the malfunction(s). After pressing the selection field, a confirmation dialog appears in which you have to confirm the reset again. The Condair RO-E then restarts.
- **Reset Settings:** With this function you can reset the parameter setting values of the control software to the last saved values. After pressing the selection field, a confirmation dialog appears in which you have to confirm the reset again.

6.3.2.3 Settings in the "Settings" submenu



- **RO Volume Flow Permeate:** With this setting you activate ("On") or deactivate ("Off") the optional volume flow measurement if the Condair RO-E(+) pure water system is equipped with the volume flow measurement option.
Factory Setting: **Off**
Options: **On or Off**
- **RO Outlet Valve:** With this setting you activate ("On") or deactivate ("Off") the optional outlet valve Y13 if the Condair RO-E(+) pure water system is equipped with the outlet valve Y13 option.
Factory Setting: **Off**
Options: **On or Off**

- **RO Min Tank Pressure Timeout:** With this setting you determine the waiting time until the warning "W124 - Min. Tank Pressure" is triggered if the minimum tank pressure is not reached within this time during pure water production.

Factory Setting: **600 seconds**

Settings range: **1 ... 600 seconds**

- **RO Max Limit:** With this setting you determine the maximum conductivity limit. If this value is exceeded, the warning "W72 - Conductivity High" appears and the system is flushed. If the conductivity value is still too high after flushing, the error "E72 - Conductivity High" appears and the Condair RO-E(+) pure water system is stopped.

Factory setting: **20 µS/cm**

Settings range: **10.0... 1000.0 µS/cm**

6.3.2.4 Software update in the "Update" submenu

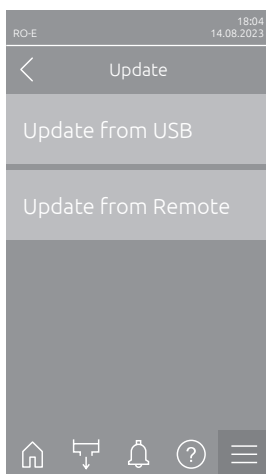

- **Update from USB:** With this function you can update the control software. The software is downloaded directly from the USB stick and then installed. Please note the information in [Section 7.7](#).
- **Update from Remote:** With this function you can update the control software. The software must already be downloaded before the update can be started. Please note the information in [Section 7.7](#).

6.3.2.5 View and export malfunctions and maintenance histories in the "Histories" submenu

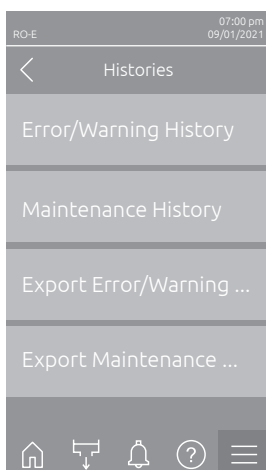

- **Error/Warning History:** With this function you can view the error and warning history list.
- **Maintenance History:** With this function you can view the maintenance history list.
- **Export Error/Warning History:** With this function you can save the error and warning history list on a USB stick.
Note: Before you carry out this function, you must insert a FAT32 formatted USB stick into the USB interface on the control board.
- **Export Maintenance History:** With this function you can save the maintenance history list on a USB stick.
Note: Before you carry out this function, you must insert a FAT32 formatted USB stick into the USB interface on the control board.

6.3.2.6 Load and export the error log file in the "Error Analyzer" submenu

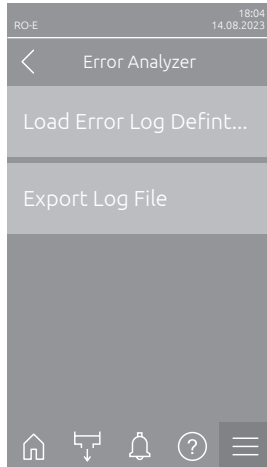

- **Load Error Log Definition** (carried out ex works): With this function you can load an "Error Log Definition file" available from Condair on a USB stick for recording malfunctions. Once the "Error Log Definition file" has been loaded, an error log file is created as soon as an error occurs during operation. This file can then be saved on a USB stick using the "Export Log File" function.
Note: Before you carry out this function, you must insert a USB stick with the "Error Log Definition" file into the USB interface on the control board.
- **Export Log File**: With this function you can save an error log file created by the control on a USB stick and send it to Condair for further analysis.
Note: Before you carry out this function, you must insert a FAT32 formatted USB stick into the USB interface on the control board.

6.3.2.7 Start operating data recording in the "USB Data Logger" submenu

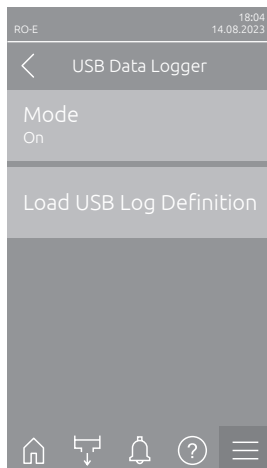

- **Mode**: With this function you can switch the operating data recording on a USB stick on or off. A new csv file is created for each day and stored on the USB stick.
Note: Before you carry out this function, you must insert a FAT32 formatted USB stick into the USB interface on the control board.
Factory setting: **Off**
Options: **Off or On**
- **Load USB Log Definition** (carried out ex works): With this function you can load a "USB log Definition file" available from Condair on a USB stick. This file determines which parameters are recorded via the USB data logger as soon as data logging is started with the "Mode" parameter.
Note: Before you carry out this function, you must insert a USB stick with the "USB log Definition file" into the USB interface on the control board.

6.3.2.8 View operating states in the submenu "Diagnostics > RO Input Diagnostics"

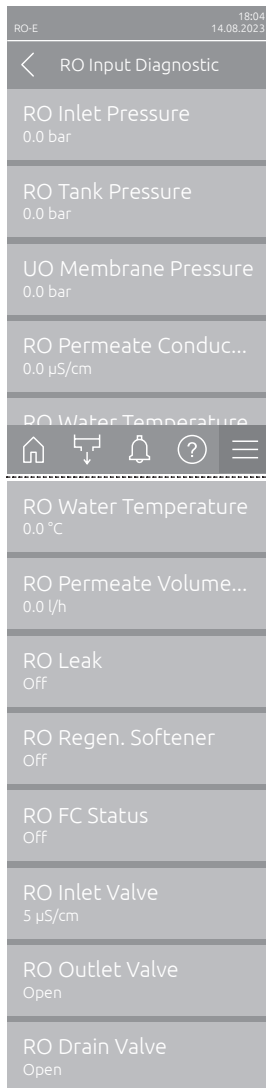

*Continued on
next page*

- **RO Inlet Pressure:** Actual inlet pressure (measured by pressure sensor PS1) at the water supply inlet of the Condair RO-E in bar.
- **RO Tank Pressure:** Actual pressure in the RO tank (measured by pressure sensor PS2) in bar.
- **RO Membrane Pressure:** Actual RO membrane inlet pressure (measured by pressure sensor PS3) in bar.
Note: This info field appears only if the pressure sensor PS3 is installed.
- **RO Permeate Conductivity:** Actual conductivity of the permeate water in µS/cm.
Note: This info field appears only if the "Conductivity measuring" - option CM or "Conductivity and temperature measuring" - option CTM is installed.
- **RO Water Temperature:** Actual temperature of the permeate water in °C.
Note: This info field appears only if the "Conductivity and temperature measuring" - option CTM is installed.
- **RO Permeate Volume Flow:** Actual volume flow of the permeate water in l/hr.
Note: This info field appears only if the "RO Permeate Volume Flow" option is installed and activated in the Service level of the control software.
- **RO Leak:** Actual status of leak monitoring.
Note: This info field appears only if the "RO Leak monitoring" option is installed and activated in the Service level of the control software.
- **RO Regen. Softener:** Actual regeneration status of the optional water softener.
Note: This info field appears only if the regeneration contact of the water softener is connected to the driver board inside control compartment of the Condair RO-E(+) pure water system and "RO Softener" option is activated in the Service level of the control software.
- **RO FC Status:** Actual status of the frequency converter. Shows "On" when frequency converter is switched on and no error is present. Contact Shows "Off" when the frequency converter is switched off or there is an error at the frequency converter.
- **RO Inlet Valve:** Actual status of the inlet valve "Y11" (Open or Closed).
- **RO Outlet Valve:** Actual status of the outlet valve "Y13" (Open or Closed).
Note: This info field appears only if the "RO Outlet Valve" option is installed and activated in the Service level of the control software.
- **RO Drain Valve:** Actual status of the drain valve "Y12" (Open or Closed).
Note: This info field appears only if the "RO Drain Valve" option is installed and activated in the Service level of the control software.

RO Permeate Valve Closed
RO Concentrate Valve Closed
RO Supply 24V Peri 23.8 V
RO Supply 5V Peri 4.9 V

- **RO Permeate Valve:** Actual status of the permeate valve "Y15" (Open or Closed).
Note: This info field only appears if the "RO Type" setting in the Service level of the control software was set to "RO-E+".
- **RO Concentrate Valve:** Actual status of the concentrate valve "Y16" ("Open" or "Closed").
Note: This info field appears only if the "RO Concentrate Valve" option is installed and activated in the Service level of the control software.
- **RO Supply 24V Peri:** Effective voltage of the 24 V DC supply.
- **RO Supply 5V Peri:** Effective voltage of the 5 V DC supply.

6.3.2.9 Checking the relays of the remote operating and fault indication board in the "Diagnostics > RFI Diagnostics" submenu

Note: This submenu is only accessible if the remote operating and fault indication board has been installed and activated in the Service level of the control software.

RO-E 18:04 14.08.2023
< RFI Diagnostics
Error Off
Service Off
Running Off
Unit On Off
Furnace Off
Home, RFI, Bell, Question mark, Menu icons
Furnace Off

- **Error:** Activation and deactivation of the "Error" relay.
- **Service:** Activation and deactivation of the "Service" relay.
- **Running:** Activation and deactivation of the "Running" relay.
- **Unit On:** Activation and deactivation of the "Unit On" relay.
- **Furnace:** Activation and deactivation of the "Furnace" relay.

6.3.3 Communication settings in the "Network" submenu

In the "Network" submenu you determine the parameters for digital communication protocols.

6.3.3.1 Accessing the "Network" submenu

Access the "Network" submenu as shown below.

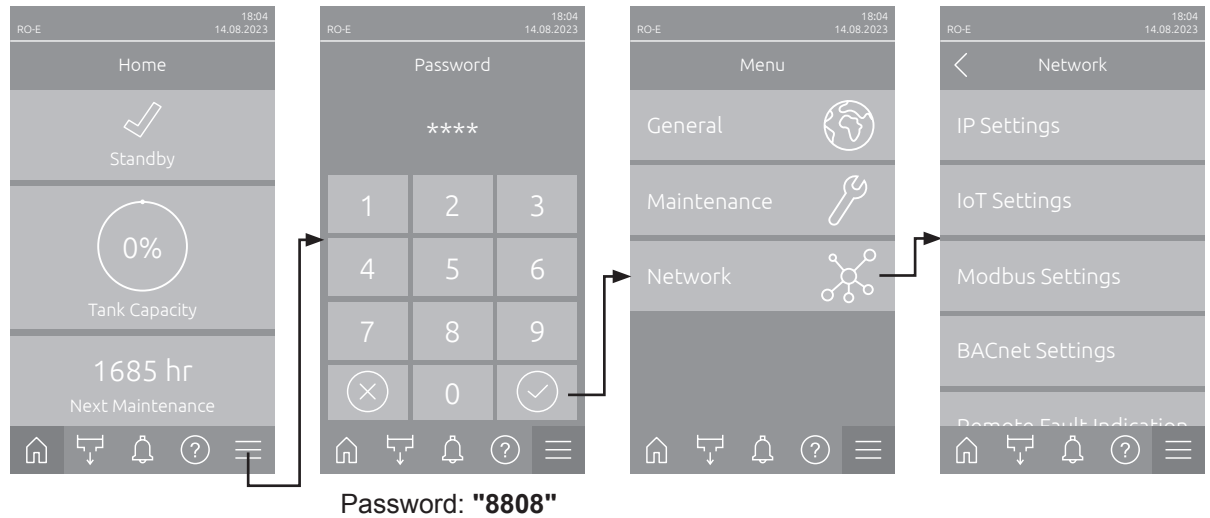

6.3.3.2 Settings in the "IP Settings" submenu

The following network settings are used only for the communication via the integrated BACnet IP, Modbus TCP or IoT interface.

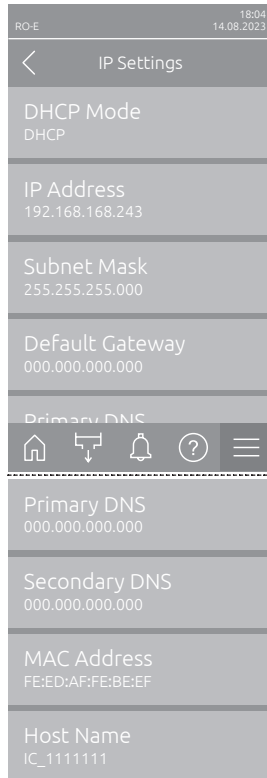

- **DHCP Mode:** with this setting you determine whether you want to assign the IP Address, the Subnet Mask, the Standard Gateway as well as the Primary and Secondary DNS address as fixed values or whether these should be dynamically assigned via a DHCP server.
Note: If no address can be assigned via a DHCP server when "DHCP Mode" is set to "DHCP", an APIPA (Automatic Private IP Addressing) is automatically assigned. This is in the range from 169.254.1.0 to 169.254.254.255. The subnet mask is set to 255.255.0.0 and the standard gateway remains 0.0.0.0.
Factory setting: **DHCP**
Options: **DHCP** (dynamic assignment)
Fixed (fixed assignment)
- **IP Address:** This field shows the actual IP address of Condair RO-E assigned manually or assigned by a DHCP server.
If the parameter "DHCP Mode" is set to "Fixed", the IP address of Condair RO-E can be set via this field. If the parameter "DHCP Mode" is set to "DHCP", the IP address of Condair RO-E is assigned by a DHCP server.
- **Subnet Mask:** This field shows the actual subnet mask of the IP network assigned manually or assigned by a DHCP server.
If the parameter "DHCP Mode" is set to "Fixed", the subnet mask can be set via this field. If the parameter "DHCP Mode" is set to "DHCP", the subnet mask is assigned by a DHCP server.
- **Default Gateway:** This field shows the actual IP address of the default gateway assigned manually or assigned by a DHCP server.
If the parameter "DHCP Mode" is set to "Fixed", the IP address of the default gateway can be set via this field. If the parameter "DHCP Mode" is set to "DHCP", the IP address of the default gateway is assigned by a DHCP server.
- **Primary DNS:** This field shows the actual IP address of the primary domain name server (DNS) assigned manually or assigned by a DHCP server.
If the parameter "DHCP Mode" is set to "Fixed", the IP address of the primary domain name server can be set via this field. If the parameter "DHCP Mode" is set to "DHCP", the IP address of the primary domain name server is assigned by a DHCP server.
- **Secondary DNS:** This field shows the actual IP address of the secondary domain name server (DNS) assigned manually or assigned by a DHCP server.
If the parameter "DHCP Mode" is set to "Fixed", the IP address of the secondary domain name server can be set via this field. If the parameter "DHCP Mode" is set to "DHCP", the IP address of the secondary domain name server is assigned by a DHCP server.
- **MAC Address:** Factory set MAC Address (Media Access Control) of Condair RO-E. Not modifiable.
- **Host Name:** Host Name of Condair RO-E automatically generated by the control. Format: "IC_"+"Serial number of Condair RO-E". Not modifiable.

6.3.3.3 Settings in the "IoT Settings" submenu

The following settings are only required for communication via IoT.

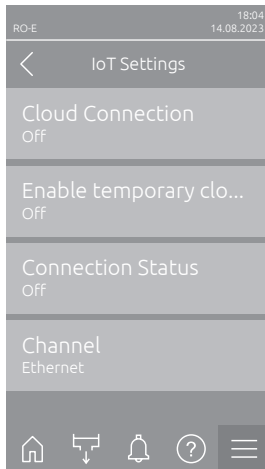

- **Cloud Connection:** ---
- **Enable temporary cloud write access:** ---
- **Connections Status:** ---
- **Channel:** ---

Important: Regarding the setting of the individual IoT parameters , please observe the instructions in the separate IoT addendum manual. For further information on IoT solutions, please contact your Condair representative.

6.3.3.4 Settings in the "Modbus Settings" submenu

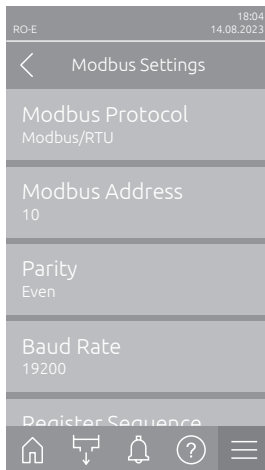

- **Modbus Protocol:** with this setting you can activate "**Modbus/RTU**" or "**Modbus/TCP**" communication via a Modbus network or deactivate ("Off") Modbus communication.
Factory setting: **Modbus/RTU**
Options: **Off, Modbus/RTU or Modbus/TCP**

Important: regarding the setting of the individual Modbus parameters as well as the wiring of the Condair RO-E for the Modbus communication, please observe the instructions in the separate Modbus addendum manual. This manual can be requested from your Condair representative.

6.3.3.5 Settings in the "BACnet Settings" submenu

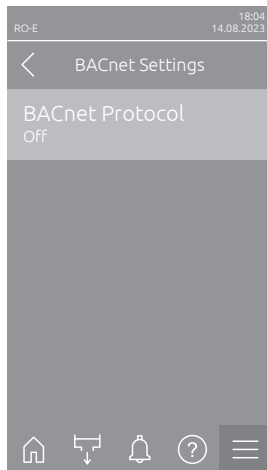

- **BACnet Protocol:** with this setting you can activate ("BACnet MS/TP" or "BACnet/IP") or deactivate ("Off") the communication via the integrated BACnet interfaces.

Factory setting: **Off**

Options: **Off** (BACnet interface deactivated)

MS/TP Master (BACnet MS/TP Master via RS 485 interface)

MS/TP Slave (BACnet MS/TP Slave via RS 485 interface)

BACnet/IP (BACnet/IP via RJ45 interface)

Important: regarding the setting of the individual BACnet parameters as well as the wiring of the Condair RO-E for the BACnet IP or BACnet MS/TP communication, please observe the instructions in the separate BACnet addendum manual. This manual can be requested from your Condair representative.

6.3.3.6 Settings in the "Remote Fault Indication" submenu

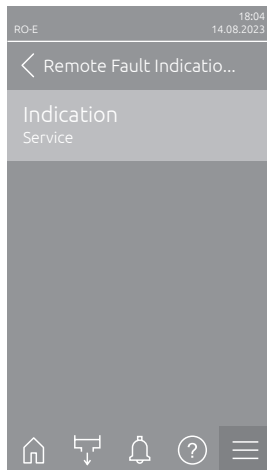

- **Indication:** With this setting you determine whether maintenance messages ("Service") only or all Warning messages ("Warning") are outputted via the service relay of the remote operating and fault indication board.

Factory setting: **Service**

Options: **Service** or **Warning**

7 Maintenance

7.1 Important notes on maintenance

Qualification of personnel

All listed maintenance work **must only be carried out by a Condair service technician or by appropriately trained technical personnel authorized by Condair**. It is the owner's responsibility to verify proper qualification of the personnel.

General note

The instructions and details for maintenance work must be followed and upheld.

Only the maintenance work described in this documentation may be carried out.

Only use original Condair spare parts to replace faulty parts.

Safety

Some maintenance work requires removal of the unit cover. Please note the following:



DANGER!
Risk of electric shock!

The Condair RO-E(+) pure water system is mains powered. Live parts may be exposed when the control compartment or the terminal box of the pump motor is/are open. Touching live parts may cause severe injury or danger to life.

Prevention: Before carrying out any work on the components of the Condair RO-E(+) pure water system take the system out of operation as described in [Section 5.3](#) and secure the system against inadvertent power-up.

Important: The frequency converter in the Condair RO-E(+) pure water system contains capacitors. These can remain charged with a potentially deadly voltage for a certain period of time after the Condair RO-E(+) pure water system has been disconnected from the power supply. Therefore, wait at least 10 minutes after disconnecting the power supply. Then make sure the appropriate contacts on the frequency converter and the terminals on the pump motor are free of voltage before starting any work on these components!



CAUTION!

The electronic components inside the control compartment of the Condair RO-E(+) pure water system, the external control unit and the control compartment/control unit of the Condair humidifier are sensitive to electrostatic discharge. Before carrying out installations work inside these units, appropriate measures must be taken to protect the electronic components against damage caused by electrostatic discharge (ESD protection).

7.2 Maintenance work

7.2.1 Maintenance indication

The control software of the Condair RO-E(+) or of the Condair RS steam humidifier with RO-E option contains a maintenance counter for the maintenance of the Condair RO-E(+). The maintenance counter is set on site during initial commissioning based on the water quality and the certification of the system (e.g. DGUV).

When the maintenance counter for the maintenance of the Condair RO-E(+) pure water system has expired, the warning message "W28 - Maintenance" is triggered, which indicates the maintenance of the Condair RO-E(+) pure water system must be carried out.

Note: If the maintenance of the Condair RO-E pure water system is not carried out and the maintenance counter is not reset within 7 days, the operation of the Condair RO-E(+) pure water system will be stopped and a corresponding error message will be triggered.

7.2.2 Maintenance list

As soon as the maintenance message appears, carry out the following maintenance work:

Upon completion of the maintenance work, fill out and sign the maintenance checklist (to be created by the customer) and reset the maintenance message. The relevant personnel are responsible for any maintenance tasks not performed.

Maintenance work to be carried out	Periodic maintenance (W28/E28 is shown)	Every 2 years
Checking the system		
Checking the general function of the system	X	
Reading the pump's operating hours	X	
Checking the system for leaks	X	
Water treatment plant/inlet water		
Analysis of water hardness (for water softening)	X	
Hygiene		
Taking a water sample (bacterial test) from the sampling tap	X	
Components		
Determination of the desalination rate (see Section 7.4.1.1) and, if necessary, replacement of the membranes (see Section 7.4.1.2).	X	
Check the pump condition (pressure and noise)	X	
Check and adjust the pre-pressure in the pressure tank. Make sure the diaphragm in the pressure tank is not damaged.	X	
Replacing the filter cartridge(s) of the pre-filter(s) (see Section 7.4.4)	X	
Check throttle valves (see Section 7.4.3).	X	
Replacing the membranes (see Section 7.4.1.2)		X
Check and, if necessary, replace the solenoid valves.		X
Functional test of the pressure gauge		X
Functional test of the pressure sensors		X
Functional test of the volume flow measurement		X
Functional test of the conductivity and temperature sensor		X

Maintenance work to be carried out	Periodic maintenance (W28/E28 is shown)	Every 2 years
Measured values		
Measuring conductivity at the inlet, outlet and drain	X	
Performance tests (amount of water produced versus amount of wastewater)	X	

7.3 List of preventive component replacements

Scheduled preventive replacement of components related to maintenance

Maintenance	Technical service life	Maintenance A every six months	Maintenance B every year	Maintenance C every two years	Maintenance D every four years
Water filter					
Filter 5µm	6 months	Replace	Replace	Replace	Replace
Activated carbon filter	6 months	Replace	Replace	Replace	Replace
O-ring for water filter	24 months	Check	Check	Replace	Replace
RO membrane					
LOW4 4014 XL - 14"	24 months	Check	Check	Replace	Replace
LOW4 4021 XL - 21"	24 months	Check	Check	Replace	Replace
LOW2 4014 XL - 14"	24 months	Check	Check	Replace	Replace
LOW2 4021 XL - 21"	24 months	Check	Check	Replace	Replace

7.4 Maintenance and replacement of components

7.4.1 Maintenance of the membrane(s)

7.4.1.1 Determination of the desalination rate

1. Take a water sample from the water inlet to the Condair RO-E(+) pure water system and determine the conductivity value ("InCon").
2. Take a water sample via the pure water test tap in the Condair RO-E(+) pure water unit and determine the conductivity value ("PerCon").
3. Calculate the desalination rate using the following formula:

$$\text{Desalination rate} = [1 - (\text{PerCon in } \mu\text{S/cm} / \text{InCon in } \mu\text{S/cm})] \times 100\%$$

$$\begin{aligned} &\text{Calculation example (PerCon= 10 } \mu\text{S/cm, InCon= 450 } \mu\text{S/cm)} \\ &\text{Desalination rate} = [1 - (10 / 450)] \times 100 = \mathbf{97.8\%} \end{aligned}$$

If the desalination rate is <95% or the membrane(s) have been in use for more than 2 years, the membrane(s) must be replaced.

7.4.1.2 Replacing the membrane(s)



WARNING!

Always wear disposable gloves when handling the membranes to avoid infection from any pathogens that may be present!

When installing the new membrane, always wear new disposable gloves to avoid contamination of the membrane with germs.



CAUTION!

Please ensure that the membrane was delivered properly packaged. The membrane is vacuum-sealed and preserved with a transport fluid. If the packaging film does not fit tightly around the membrane, or if the membrane is freely movable within the packaging, this indicates damaged packaging. The membrane can then dry out, compromising its proper function. If you have any questions or concerns, please contact your Condair support/representative.

Protective clothing:	Disposable gloves
Tools required:	Tools required: <ul style="list-style-type: none">- Release tool for plug-in couplings- Phillips screwdriver- Allen key 7/16" (11 mm)- Flat-nose pliers or combination pliers- Hand pump and 10 l bucket- Dishwashing detergent- Wide slotted screwdriver- 2x open-end wrenches SW14



CAUTION!

To avoid leaks, all plug-in couplings, hoses and pipes that have to be removed to replace the membrane(s) must be checked for damage and wear and replaced if necessary.
When loosening the connection(s), always pull the release ring of the JS plug-in coupling(s) all the way back to avoid damage to the plug-in couplings and the hoses.

To replace the membrane(s), proceed as follows:

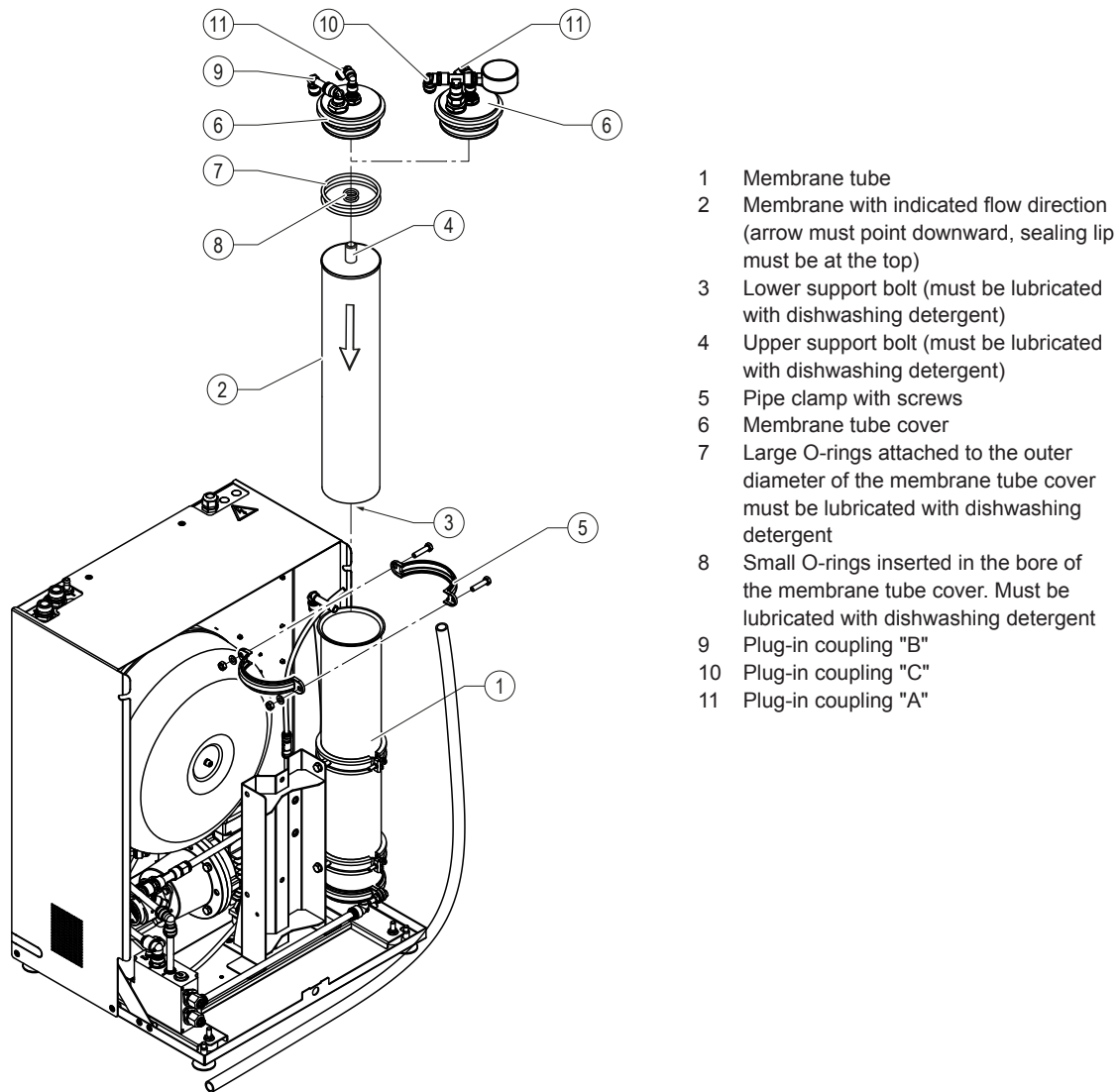

Fig. 7: Membrane replacement

1. Shut down the Condair RO-E(+) pure water system as described in the Condair RO-E(+) pure water system operating manual. Secure the system against unintentional operation.
2. Wait until the RO-E(+) has completely emptied and no more water flows from the waste water hose.
3. Disconnect the quick-connect couplings "A" and "B". The hoses do not need to be disconnected from the quick-connect couplings "A" and "B". If the "Pump Pressure Gauge" option is installed, disconnect the hose from the quick-connect coupling "C".
4. Loosen one screw on the upper pipe clamp. The second screw can be left in place. Remove the pipe clamp.
5. Pull the membrane tube cover upwards and out of the tube. The membrane tube cover may be very difficult to pull out. You can use a wide flat-blade screwdriver to help it along. **Be careful not to damage the membrane tube cover or the membrane tube when using the screwdriver!**
6. Set the membrane tube cover aside.

7. Using a 7/16" (11 mm) Allen key, turn the old membrane on the support bolt until the sealing lip is released.
8. Pull the membrane upwards using flat-nose pliers or combination pliers on the support bolt.
9. Check the inside of the membrane tube for dirt and biofilm. If cleaning is necessary:
 - Put on clean disposable gloves.
 - Clean the membrane tube, O-rings and the upper and lower membrane tube covers with luke-warm soapy water and a soft brush and disinfect if necessary.
10. Using a hand pump, you can pump out any remaining water from the membrane tubes. This will prevent water from overflowing from the membrane tube when installing the new membrane.
11. Put on new sterile disposable gloves. Then carefully remove the new membrane from the packaging without damaging it.
12. Lubricate both support bolts and the membrane seal as well as all four O-rings of the removed membrane tube covers with dishwashing liquid.

Important: Make sure these parts are sufficiently lubricated. Otherwise, the membrane will be difficult to remove during the next change!
13. Insert the new membrane into the membrane tube with the arrow facing down and the sealing lip facing up. Make sure you use the correct membrane type.
14. Replace all membrane tube covers on the membrane tubes and align them as shown below. Secure the tube clamp with the screws, nuts, and washers.

Important: Do not press the membrane tube cover down onto the membrane tube with full force. Otherwise, you will damage the membrane tube bracket.

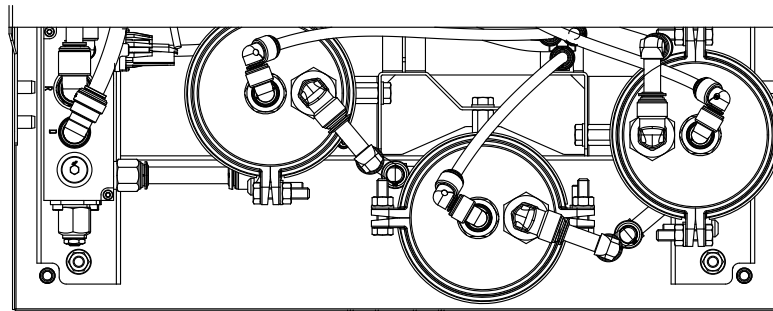

Fig. 8: Alignment of the membrane tube cover RO-E 300(+) without pressure gauge, view from above

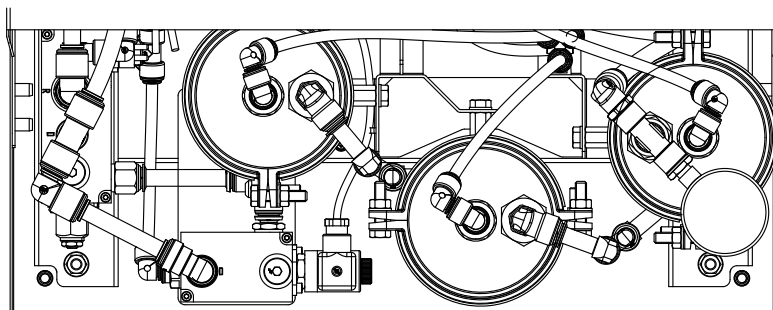

Fig. 9: Alignment of the membrane tube cover RO-E 300(+) with pressure gauge, view from above

15. Reconnect the removed plug-in couplings with the hoses in the correct place.
16. Connect the power cable to the power outlet.



DANGER!
Risk of electric shock!

After connecting the power cable, mains voltage is present at the terminals inside the control unit of the Condair RO-E(+). Do not touch any components inside the control compartment.

17. Wipe away any spilled water so you can identify any leaks.
18. Open the shut-off valve in the feed water supply line.
19. Restart the Condair RO-E(+) pure water system.
20. Check the entire system for leaks.
21. Perform a complete flush of the Condair RO-E(+) pure water system. Follow the instructions in [Section 7.4.2](#).

7.4.2 Flushing of a new membrane(s)

After installing a new membrane, it must first be "flushed", as the resistance of a new membrane is still too high, which would cause the Condair RO-E(+) pure water system to overpressurize. Furthermore, the reverse osmosis water produced in the first 30 minutes must not be used.

To do this, follow the steps below.

1. Make sure that the shut-off valve in the water supply line to the Condair RO-E(+) is closed.
2. Disconnect the reverse osmosis water inlet hose from the Condair humidifier and route it to a drain. The other end of the hose must remain connected to the Condair RO-E(+) pure water system.
3. Open the drain throttle valve "D" completely.
4. Open the recylcate throttle valve "R" according to the table in [Section 7.4.3.2](#).
5. Turn on the power switch on the Condair RO-E(+) pure water system and the Condair humidifier (if applicable).
6. Deactivate (if applicable) the "RO Volume Flow Permeate" option in the control software, according to [Section 6.3.2.3](#).
Note: The permeate volume flow monitoring must be deactivated because the permeate volume flow is still too small with a new membrane and would trigger an error message.
7. Deactivate (if applicable) the "RO Outlet Valve" option in the control software according to [Section 6.3.2.3](#).
Note: The outlet valve Y13 must be deactivated because the tank should not be filled, but the permeate water should flow directly into the drain.
8. Set the parameter "RO Min Tank Pressure Timeout" in the control software to 600 seconds (see [Section 6.3.2.3](#)).
Note: This setting must be changed because the tank is not filled when the membrane is flushed and this would trigger an error message.
9. Set the parameter "RO Max Limit" in the control software to 100 µS/cm (see [Section 6.3.2.3](#)).
10. Open the shut-off valve in the water supply line to the Condair RO-E(+) pure water system. The Condair RO-E(+) pure water system will restart.

11. Close the drain throttle valve "D" until the "RO Membrane Pressure" (PS3) is set according to the correct pressure in the table in [Section 7.4.3.2](#).
12. Let the Condair RO-E(+) pure water system run for 60 minutes. After this time, the "RO Membrane Pressure" (PS3) will decrease.
13. Return the drain throttle valve "D" and the recycle throttle valve "R" to their original positions according to [Section 7.4.3.2](#). Ensure that the correct membrane pressure (PS3) is set. Use a measuring cup and a clock to measure the flow rate from the drain water hose to check whether the throttle valves are correctly adjusted. Flow rates see table in [Section 7.4.3.2](#).
14. Set the parameter "RO Min Tank Pressure Timeout" in the control software back to the default value (see [Section 6.3.2.3](#)).
15. Set the parameter "RO Max Limit" in the control software back to the desired value (see [Section 6.3.2.3](#)).
16. Reactivate (if applicable) the option "RO Volume Flow Permeate" in the control software, according to [Section 6.3.2.3](#).
17. Reactivate the "RO Outlet Valve" option in the control software (if applicable), according to [Section 6.3.2.3](#).
18. Switch off the Condair RO-E(+) pure water system using the unit switch or the mains isolator.
19. Reattach the reverse osmosis water hose to the Condair humidifier.

7.4.3 Adjustment and maintenance of throttle valves

7.4.3.1 Overview and description of the throttle valves

The Condair RO-E(+) pure water system features three throttle valves that can be manually adjusted using a 4 mm Allen key. To open the throttle valve (increase flow rate), turn counterclockwise. To close the throttle valve (decrease flow rate), turn clockwise. The nut secures the adjusting screw to prevent it from rotating on its own.

- **Drain throttle valve (D):**

This throttle valve regulates the flow rate of the concentrate coming from the membrane and directs it directly into the wastewater.

- **Recyclate throttle valve (R):**

This throttle valve regulates the flow rate of the concentrate in the recycle circuit, which comes from the membrane. The recycle line carries the concentrate to the inlet block, where it mixes with the feedwater.

- **Throttle valve conductivity adjustment (option):**

This throttle valve regulates the flow rate of the concentrate coming from the membrane and transporting it into the permeate line to the tank. This allows the conductivity of the permeate to be increased in a controlled manner.

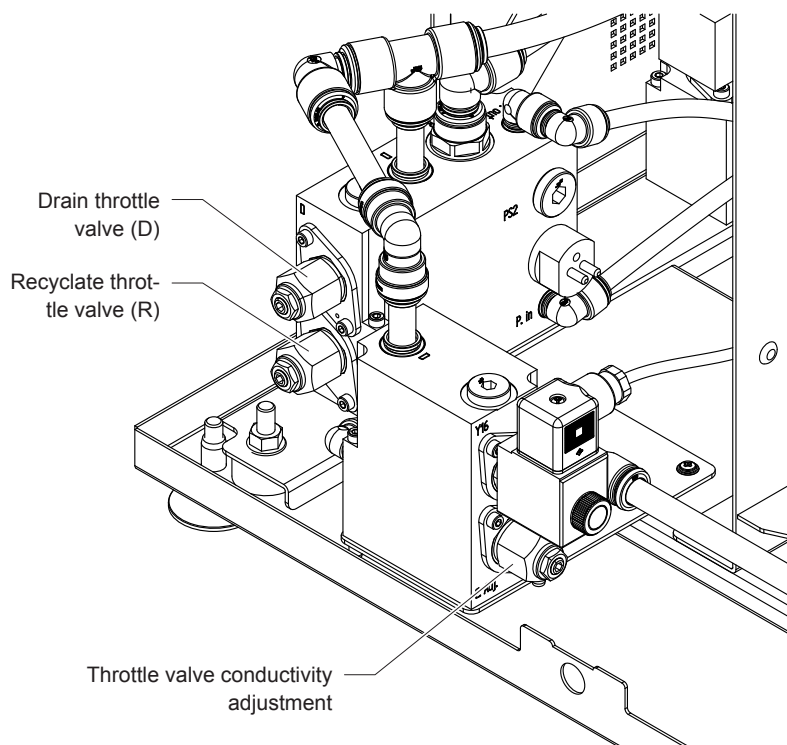

Fig. 10: Position of the throttle valves in the device

7.4.3.2 Table for adjusting and checking the throttle valves

The following table is used to check the minimum wastewater flow rate from the wastewater hose. The flow rate must not be lower than the value specified in the table. If the flow rate is lower, the Condair RO-E(+) pure water system may become calcified.

The wastewater flow rate may only be measured while the tank is being filled.

Note: The values shown in the table below are approximate reference values and may differ from the actual settings!

Device model	Water type	Min. wastewater flow rate [l/hr]	Membrane pressure [bar]	Adjusting screw Drain throttle valve dimension X [mm]	Adjusting screw Recyclate throttle valve dimension X [mm]
RO-E 40	---	170	10	6.2	7.2
RO-E+ 40	---	135	10	6.0	7.8
RO-E(+) 100	Soft water	60	11	6.0	8.0
	Hard water	170	11	6.8	7.3
RO-E(+) 200	Soft water	60	11	6.0	8.0
	Hard water	380	11	9.0	6.5
RO-E(+) 300	Soft water	80	12	6.0	8.2
	Hard water	380	12	9.0	7.2

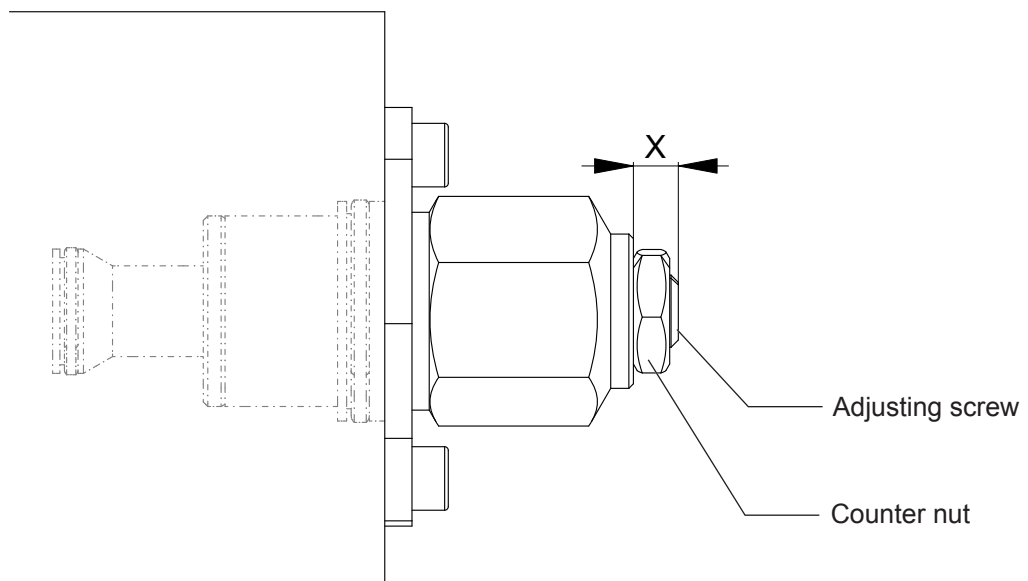





Fig. 11: Throttle valve adjustment by measuring dimension X

To avoid measuring dimension X of the adjusting screw, it can also be adjusted using the position of the Allen key. When the adjusting screw is fully open, dimension X is = 12.7 mm. Note the position of the

Allen key and turn the adjusting screw **clockwise**, either in full turns (change in dimension X = 0.5 mm) or half turns (change in dimension X = 0.25 mm), until the desired dimension X is reached. Refer to the following table for the corresponding values.

Dimension "X" for throttle valve adjustment	Full turn	open	close
			
5.2 mm	15		
5.7 mm	14		
6.2 mm	13		
6.7 mm	12		
7.2 mm	11		
7.7 mm	10		
8.2 mm	9		
8.7 mm	8		
9.2 mm	7		
9.7 mm	6		
10.2 mm	5		
10.7 mm	4		
11.2 mm	3		
11.7 mm	2		
12.2 mm	1		
12.7 mm	0		

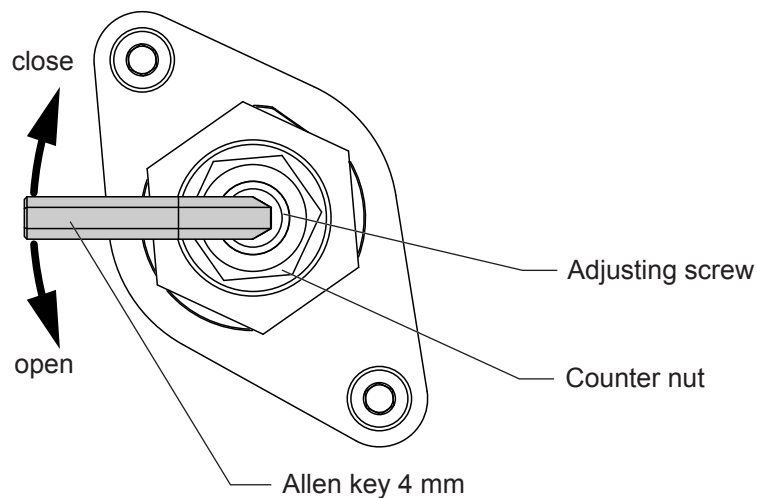

Fig. 12: Throttle valve adjustment by counting the turns of the Allen key.

7.4.3.3 Maintenance of throttle valves

The drain throttle valve and the recylate throttle valve must be checked **annually** for limescale to ensure

the proper functioning of the Condair RO-E(+) pure water system. The throttle valves cannot become limescaled unless they are incorrectly adjusted or the inlet water parameters have changed.

To do this, proceed as follows.

1. Shut down the Condair RO-E(+) pure water system as described in the Condair RO-E(+) pure water system operating manual. Secure the system against unintentional operation.
2. Wait until the RO-E(+) has completely emptied and no more water flows from the waste water hose.
3. Remove the two throttle valves by loosening the two screws.
4. Check the throttle valves for limescale deposits.

If limescale deposits are present:

- Clean both throttle valves with descaling agent.
 - Clean the hole in the valve block.
 - Check that both throttle valves are correctly adjusted according to the table in [Section 7.4.3.2](#).
5. Check the O-rings for damage and lubricate them with dishwashing liquid before reinstalling to prevent damage during assembly.
 6. Reinstall the throttle valves into the correct holes.
 7. Connect the power cable to the power outlet.



DANGER!
Risk of electric shock!

After connecting the power cable, mains voltage is present at the terminals inside the control unit of the Condair RO-E(+). Do not touch any components inside the control unit.

8. Wipe away any spilled water so you can identify leaks.
9. Open the shut-off valve in the feed water supply line.
10. Restart the Condair RO-E(+) pure water system.
11. Check the entire system for leaks.

7.4.4 Replacement of the filter cartridge(s) of the pre-filter(s)

For the replacement of the filter cartridge(s) please refer to the separate instructions of the pre-filter(s) used.

7.4.5 Maintenance work to be carried out on the optional water softener

Please refer to the separate instructions for your water softener for the maintenance interval and the maintenance work to be carried out on the optional water softener.

7.5 Maintenance history

To view the maintenance history of the Condair RO-E(+) pure water system, follow the instructions in [Section 6.3.2.5](#).

To save the error and maintenance history of the Condair RO-E(+) pure water system on a USB stick, follow the instructions in [Section 8.5](#).

7.6 Reset maintenance counter

The maintenance counter for the maintenance can only be reset by the Condair service technician or service personnel authorized by Condair.

7.7 Performing a software update

To update the control software of the Condair RO-E(+) pure water system or the firmware of one of its electronic boards, proceed as follows:

Note: To update the Condair RO-E(+) control software or the firmware of one of the Condair RO-E(+) electronic boards via the control software of the humidifier of an integrated system (e.g. Condair RS) please refer to operation manual of the corresponding humidifier.

1. Set the **<On/Off>** switch on the right side of the Condair RO-E(+) pure water system to the "OFF" position.
2. Carefully insert FAT32 formatted USB stick containing the corresponding software or firmware update into the USB port of the external control unit.
Note: In order to update the control software a USB stick with a valid software/firmware update (the update file must be on the highest level outside of any folder) must be connected to the USB port of the external control unit. Otherwise, an appropriate error message appears when starting the software/firmware update.
3. Set the **<On/Off>** switch on the right side of the Condair RO-E(+) pure water system to the "ON" position.
4. When the home screen appears on the external control unit, select the **<Menu>** button, then enter the password (8808) to login.
5. Select the function "Update from USB" (Path: "Menu > Password. 8808 > Maintenance > Update". See also [Section 6.3.2.4](#)).
6. The software update confirmation screen appears. Press the **<Continue>** button.
7. An information window appears after a few minutes with information on the software update. Press the **<Reboot>** button to start the software update.

The update starts. During the update, the display is inactive and the LED is flashing blue. If the update has completed the Condair RO-E(+) control unit returns to the home screen.



CAUTION!

Do not interrupt a software/firmware update once it has started. Wait until updating is completed. A corrupted control software/firmware can render the external control unit or the electronic board unusable.

Note: If software/firmware update is accidentally interrupted, the control unit will not operate, but the software/firmware update can be resumed by leaving the USB key inserted in the external control unit and power cycling the Condair RO-E(+) pure water system. The integrated controller will detect the control software/firmware was not properly installed and restart the update.

8. Set the **<On/Off>** switch on the right side of the Condair RO-E(+) pure water system to the "OFF" position, then remove the USB stick from the external control unit.
9. Set the Condair RO-E(+) pure water system into operation as described in [Section 5.1](#).

8 Fault elimination

8.1 Important notes on fault elimination

Qualification of personnel

Repair work must be carried out only by **qualified and well-trained professionals authorized by the owner**.

Repair work relating to the electrical installation must be carried out by an electrician or professionals authorized by the owner.

General notes

Repair work on the frequency converter and the reverse osmosis pump must be carried only by your Condair representative.

Only use original spare parts from your Condair representative to replace defective parts.

Safety



DANGER!
Risk of electric shock!

The Condair RO-E(+) pure water system is mains powered. Live parts may be exposed when the control compartment or the terminal box of the pump motor is/are open. Touching live parts may cause severe injury or danger to life.

Prevention: Before carrying out any work on the components of the Condair RO-E(+) pure water system take the system out of operation as described in [Section 5.3](#) and secure the system against inadvertent power-up.

Important: The frequency converter in the Condair RO-E(+) pure water system contains capacitors. These can remain charged with a potentially deadly voltage for a certain period of time after the Condair RO-E(+) pure water system has been disconnected from the power supply. Therefore, wait at least 10 minutes after disconnecting the power supply. Then make sure the appropriate contacts on the frequency converter and the terminals on the pump motor are free of voltage before starting any work on these components!



CAUTION!

The electronic components inside the control unit are very sensitive to electrostatic discharge.

Prevention: Before carrying out any repair work to the electrical or electronic equipment in the control compartment, appropriate measures must be taken to protect the respective components against damage caused by electrostatic discharge (ESD protection).

8.2 Fault indication

Malfunctions during operation detected by the control software are indicated on the external control unit

by a corresponding **Warning** message (Status LED lights up yellow and the exclamation mark symbol is displayed in the device and error status field of the home screen) or **Error** message (Status LED lights up red and the cross symbol is displayed in the device and error status field of the home screen).

Warning

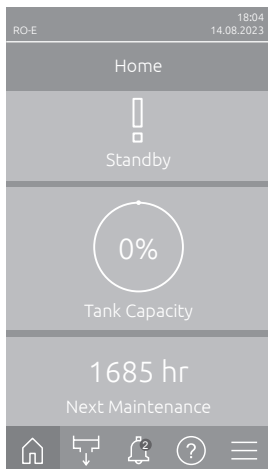

Temporary problems (e.g., water supply interrupted for a short time) or malfunctions which cannot cause damage to the system are indicated with a warning message, additionally the status LED lights up yellow. **If the cause of the malfunction disappears of its own accord within a certain period of time, the warning message will automatically switch off otherwise an error message is triggered.**

Note: Warnings can be indicated also via the service relay of the remote operating and fault indication. Therefore the warning indication via the service relay must be activated in the "Network" submenu of the control software (see [Section 6.3.3.6](#)).

Error

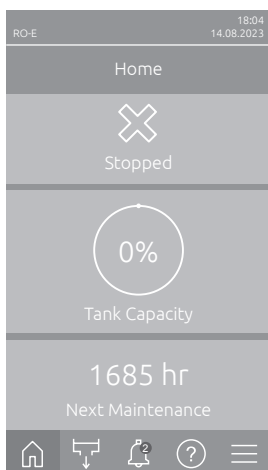

Malfunctions where further operation is not possible any longer or malfunctions which can damage the Condair RO-E(+) pure water system are indicated with an error message, additionally the status LED lights up red. If such a malfunction occurs the operation of the Condair RO-E(+) pure water system is limited only, or the system will be stopped automatically.

By pressing on the <Events> button in the home screen the error list shown with all active warning and error messages. By pressing on the corresponding Warning or Error entry additional information regarding the malfunction are displayed (see display on the far right).

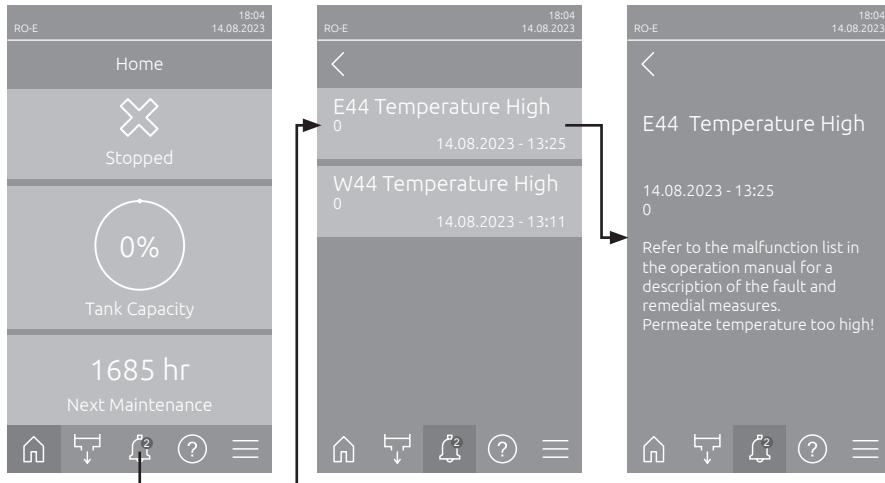

8.3 Malfunction list

Most operational malfunctions are not caused by faulty equipment but rather by improper installation or disregard of planning guidelines. Therefore, a complete malfunction diagnosis always involves a thorough examination of the entire system (e.g., hose connections, fittings, etc.).

Note: Remedial measures highlighted in gray in the malfunction list may only be remedied by a Condair service technician or a service center authorized by Condair. If applicable, contact your Condair representative.

Code		Message	Information	
Warning	Error		Possible causes	Remedy
W01	—	Smartcard	No communication with Smartcard!	Contact your Condair representative.
			No Smartcard installed.	
			Smartcard not valid or defective.	
W09	E09	Temperature Low	Permeate temperature too low! Note: If the temperature of the permeate water remains below a set value after the warning message has appeared and after an automatic flushing has been carried out, an error is triggered. The Condair RO-E pure water system stops operation and the water system including the pure water tank is emptied.	
			The inlet water temperature is too low.	Feed in warmer supply water.
			Temperature sensor is missing, faulty or defective.	Contact your Condair representative
—	E10	Controller Reset	The control unit (Integrated Controller) has been automatically restarted due to a software problem.	
			The control unit (Integrated Controller) has been automatically restarted due to a software problem	Contact your Condair representative if this problem regularly occurs.
—	E15	Program Fault	The Countdown timer has expired.	
			Countdown Password must be entered.	Contact your Condair representative.

Code		Message	Information	
Warning	Error		Possible causes	Remedy
W22	E22	Water Missing	The inlet valve Y11 is open, but the water pressure is not reached within the set time. Note: The Condair RO-E(+) pure water system has stopped operation and the water system including the pressure tank has been emptied. The error message is automatically reset after the fault has been eliminated.	
			Water supply closed.	Check/open shut-off valve in supply water line.
			Optional pre-filter(s) clogged.	Replace filter cartridge(s) in the optional pre-filter(s).
			Optional Water softener is refreshing.	Wait until refreshing (duration approx. 2 h) has finished.
W44	E44	Temperature High	Permeate temperature too high! Note: The Condair RO-E(+) pure water system stops operation and the water system including the pressure tank is emptied.	
			The inlet water temperature is too high.	Feed in colder supply water.
			Temperature sensor is missing, faulty or defective	Contact your Condair representative.
—	E48	Temperature Sensor	Invalid signal from temperature sensor permeate! Note: The Condair RO-E(+) pure water system has stopped operation and the water system including the pressure tank has been emptied.	
			Temperature sensor not connected or not connected correctly.	Check / correctly connect temperature sensor.
			Temperature sensor incorrectly configured.	Contact your Condair representative.
			Temperature sensor defective.	
—	E54	RO Leak Monitoring	Leak of water detected! Note: The Condair RO-E(+) pure water system has stopped operation and the water system including the pressure tank has been emptied.	
			Leakage in the water system detected.	Check/seal supply water line, water drain line, hose connections inside and outside of the Condair RO-E(+) pure water system.
—	E58	Pressure Sensor Inlet	Invalid signal from inlet water pressure sensor PS1! Note: The Condair RO-E(+) pure water system has stopped operation and the water system including the pressure tank has been emptied.	
			Pressure sensor PS1 not or not correctly connected.	Contact your Condair representative.
			Pressure sensor PS1 wrong configured.	
			Pressure sensor PS1 defective.	
W68	E68	Invalid Flow Signal	Permeate flow out of valid range! Note: If the permeate flow drops below a set value after the warning message appears, an error is triggered. The Condair RO-E(+) pure water system stops operation and the water system including the pressure tank is emptied.	
			Permeate flow too low.	Contact your Condair representative.
			Flow sensor not connected or not connected correctly.	
			Flow sensor configured incorrectly.	
			Membrane(s) reached end of life	

Code		Message	Information	
Warning	Error		Possible causes	Remedy
—	E69	RO Inlet Pressure	Inlet pressure out of range! Note: The Condair RO-E(+) pure water system has stopped operation and the water system including the pressure tank has been emptied.	
			Inlet water pressure out of range.	Check water inlet pressure.
			Water supply closed.	Check/open shut-off valve in the supply water line.
			Optional pre-filter clogged.	Replace the filter cartridge(s) of the optional pre-filter(s).
			Optional water softener is regenerating.	Wait until regeneration is complete (duration: approx. 2 h).
	Membrane(s) reached end of life	Contact your Condair representative.		
—	E70	Conductivity Sensor	Invalid signal from conductivity sensor permeate! Note: The Condair RO-E(+) pure water system has stopped operation and the water system including the pressure tank has been emptied.	
			Conductivity sensor not connected or not connected correctly.	Check / correctly connect conductivity sensor.
			Conductivity sensor incorrectly configured.	Contact your Condair representative.
			Conductivity sensor defective.	
W72	E72	Conductivity High	Permeate conductivity high! Note: The Condair RO-E(+) pure water system remains in normal operation (W72) or has stopped operation and the water system including the pressure tank has been emptied (E72).	
			Throttle valves are set incorrectly.	Contact your Condair representative.
			Membrane seals are not fitted/not fitted correctly or are defective.	
			Wrong membrane(s) installed.	
	Membrane(s) reached end of life			
—	E73	Timeout Pressure Relief	The automatic water system draining has not been performed within the set time! Note: The Condair RO-E(+) pure water system has stopped operation and the water system including the pressure tank has been emptied.	
			Drain blocked.	Check/clean drain.
			Valves inside the Condair RO-E(+) defective.	Contact your Condair representative.
—	E74	Keep Alive	Communication between control board and driver board interrupted! Note: The Condair RO-E(+) pure water system has stopped operation and the water system including the pressure tank has been emptied. The error message is automatically reset after the fault has been eliminated.	
			Driver board not connected.	Contact your Condair representative.
			Wrong driver board installed.	
			Driver board defective.	
—	E75	RO Tank Pressure	Pressure tank pressure out of range! Note: The Condair RO-E(+) pure water system has stopped operation and the water system including the pressure tank has been emptied.	
			Pressure in the pressure tank outside the valid range.	Check the pressure in the pressure tank.
—	E76	RO Membrane Pressure	Membrane pressure out of range! Note: The Condair RO-E(+) pure water system has stopped operation and the water system including the pressure tank has been emptied.	
			Membrane pressure outside the valid range!	Check membrane pressure.
			Throttle valves are set incorrectly.	Check throttle settings.
			Wrong membrane(s) installed	Contact your Condair representative.
			Condair RO-E(+) has been incorrectly configured	

Code		Message	Information	
Warning	Error		Possible causes	Remedy
—	E77	Y12	Error on drain valve Y12! Note: The Condair RO-E(+) pure water system has stopped operation and the water system including the pressure tank has been emptied.	
			Valve Y12 not electrically connected or coil defective.	Contact your Condair representative.
—	E78	Y13	Error on outlet valve Y13! Note: The Condair RO-E(+) pure water system has stopped operation and the water system including the pressure tank has been emptied.	
			Valve Y13 not electrically connected or coil defective.	Contact your Condair representative.
—	E79	Y15	Error on permeate valve Y15! Note: The Condair RO-E(+) pure water system has stopped operation and the water system including the pressure tank has been emptied.	
			Valve Y15 not electrically connected or coil defective.	Contact your Condair representative.
—	E80	USB Data Logger	USB data logger fault!	
			USB data logger not connected or defective.	Check/replace USB data logger.
W82	E82	Driver Missing	Communication with driver board interrupted! Note: The Condair RO-E(+) pure water system has stopped operation and the water system including the pressure tank has been emptied. The error message is automatically reset after the fault has been eliminated.	
			RS485 Bus to driver board interrupted.	Contact your Condair representative.
—	E84	Driver Defective	Unknown fault on driver board! Note: The Condair RO-E(+) pure water system has stopped operation and the water system including the pressure tank has been emptied. The error message is automatically reset after the fault has been rectified.	
			Driver board defective.	Contact your Condair representative.
—	E85	Driver ID Wrong	Driver board ID wrong! Note: The Condair RO-E(+) pure water system has stopped operation and the water system including the pressure tank has been emptied. The error message is automatically reset after the fault has been eliminated.	
			Wrong driver board connected or SAB address wrong.	Contact your Condair representative.
—	E86	Driver Incompatible	Wrong version of driver board! Note: The Condair RO-E(+) pure water system has stopped operation and the water system including the pressure tank has been emptied. The error message is automatically reset after the fault has been eliminated.	
			Wrong version of driver board.	Contact your Condair representative.
—	E87	Local 24V Supply	Local 24V supply out of valid range! Note: The Condair RO-E(+) pure water system has stopped operation and the water system including the pressure tank has been emptied. The error message is automatically reset after the fault has been eliminated.	
			Short circuit on supply module or supply module defective.	Contact your Condair representative.
—	E88	Local 5V Supply	Local 5V supply out of valid range! Note: The Condair RO-E(+) pure water system has stopped operation and the water system including the pressure tank has been emptied. The error message is automatically reset after the fault has been eliminated.	
			Short circuit on supply module or supply module defective.	Contact your Condair representative.
—	E89	Local Reference Supply	Local reference voltage out of valid range! Note: The Condair RO-E(+) pure water system has stopped operation and the water system including the pressure tank has been emptied. The error message is automatically reset after the fault has been eliminated.	
			DC supply faulty or supply line interrupted.	Contact your Condair representative.

Code		Message	Information	
Warning	Error		Possible causes	Remedy
—	E91	Pressure Instable	Water inlet pressure unstable! Note: The Condair RO-E(+) pure water system has stopped operation and the water system including the pressure tank has been emptied.	
			Shut-off valve in the supply water line not fully open.	Check/completely open shut-off valve.
			Cross section of the supply line too small.	Install supply water line with larger cross section (min. ø10/12 mm).
			Optional pre-filter(s) clogged.	Clean optional pre-filter(s) and replace filter cartridge(s).
W92	E92	RO Maintenance	The maintenance interval for the maintenance of the Condair RO-E(+) pure water system has expired. Note: If the system service is not performed and the maintenance message is not reset within 7 days after the maintenance message has appeared a fault message is triggered! The Condair RO-E(+) pure water system stops operation and the water system including the pressure tank is emptied.	
			Condair RO-E(+) pure water system service due.	Perform system service on the Condair RO-E(+) pure water system and reset maintenance counter.
—	E93	FC Error	Monitoring of the frequency converter has triggered! Note: The Condair RO-E(+) pure water system has stopped operation and the water system including the pressure tank has been emptied.	
			Short circuit on motor cable.	Contact your Condair representative.
			Signal cable connected incorrectly.	
			Pump, Motor and/or frequency converter defective.	
—	E114	Y16	Error on auxiliary concentrate valve Y16! Note: The Condair RO-E(+) pure water system has stopped operation and the water system including the pressure tank has been emptied.	
			Ventil Y16 elektrisch nicht angeschlossen oder Spule defekt.	Contact your Condair representative.
—	E115	Pressure Sensor Tank	No valid signal from pressure tank pressure sensor! Note: The Condair RO-E(+) pure water system has stopped operation and the water system including the pressure tank has been emptied.	
			Pressure sensor PS2 not connected or not connected correctly	Drucksensor PS2 prüfen / korrekt anschliessen.
			Pressure sensor PS2 incorrectly configured	Contact your Condair representative.
			Pressure sensor PS2 defective.	
—	E116	Pressure Sensor Membrane	No valid signal from membrane pressure sensor! Note: The Condair RO-E(+) pure water system has stopped operation and the water system including the pressure tank has been emptied.	
			Pressure sensor PS3 not connected or not connected correctly.	Drucksensor PS3 prüfen / korrekt anschliessen.
			Pressure sensor PS3 incorrectly configured	Contact your Condair representative.
			Pressure sensor PS3 defective.	
—	E119	Inlet Pressure Frozen	Inlet pressure didn't change in the preset time! Note: The Condair RO-E(+) pure water system has stopped operation and the water system including the pressure tank has been emptied.	
			Pressure sensor PS1 defective.	Contact your Condair representative.
—	E123	Membrane Pressure Frozen	Membrane pressure didn't change in the given time. Note: The Condair RO-E(+) pure water system has stopped operation and the water system including the pressure tank has been emptied.	
			Pressure sensor PS3 defective	Contact your Condair representative.

Code		Message	Information	
Warning	Error		Possible causes	Remedy
W124	E124	Min. Tank Pressure	The minimal tank pressure is not reached within time.	
			Leakage in the system.	Check system for leaks
			Error delay set too short.	Contact your Condair representative.
			Water supply closed.	Check/open shut-off valve in water supply line.
			Optional Pre-filter clogged.	Replace filter cartridges in the optional pre-filter.
			Optional Water softener is refreshing.	Wait until refreshing (duration approx. 2 h) has finished.
—	E127	Tank Pressure Frozen	Tank pressure didn't change in the given time. Note: The Condair RO-E(+) pure water system has stopped operation and the water system including the pressure tank has been emptied.	
			Pressure sensor PS2 defective	Contact your Condair representative.
W146	—	Softener is regenerating	The optional water softener is regenerating! Note: The Condair RO-E(+) pure water system has stopped operation and the water system including the pressure tank has been emptied. After regeneration of the water softener has finished the Condair RO-E(+) pure water system automatically resumes normal operation.	
			Optional water softener is regenerating.	Wait until regeneration is complete (duration: approx. 2 h).
—	E147	Unaccepted parameter	Tank pressure limits are incorrect (Min, Start, End or Max)! Note: The Condair RO-E(+) pure water system has stopped operation and the water system including the pressure tank has been emptied. The error message is automatically reset after the fault has been eliminated.	
			Start and/or end pressure have illogical values.	Contact your Condair representative.
			Min, start, end and/or max pressure have illogical values.	
W148	E148	RO Regular Hygiene Disinfection	Day counter for the disinfection has expired! Note: If the disinfection is not performed and the disinfection counter is not reset within set time after the warning message has been triggered an error message is triggered! The Condair RO-E(+) pure water system stops operation and the water system including the pressure tank is emptied.	
			Disinfection due.	Contact your Condair representative.
—	E149	RO Down Time Hygiene Disinfection	The device has been idle for a long time and needs to be disinfected	
			Disinfection due.	Contact your Condair representative.
—	E153	Y11	Error on inlet valve Y11. Note: The Condair RO-E(+) pure water system has stopped operation and the water system including the pressure tank has been emptied.	
			Inlet valve Y11 not connected or coil defective.	Contact your Condair representative.
W157	—	Software download from USB failed	Software download from USB failed. Note: The Condair RO-E(+) pure water system has stopped operation and the water system including the pressure tank has been emptied.	
			Connection aborted during software download from USB stick or faulty update file.	Contact your Condair representative.
W158	—	Software download from Cloud failed	Software download from Cloud failed. Note: The Condair RO-E(+) pure water system has stopped operation and the water system including the pressure tank has been emptied.	
			Connection aborted during software download from Cloud or faulty update file.	Contact your Condair representative.

Code		Message	Information	
Warning	Error		Possible causes	Remedy
—	E162	Software update failed	Software update failed. Note: The Condair RO-E(+) pure water system has stopped operation and the water system including the pressure tank has been emptied.	
			Integrated controller switched off during update process or invalid software version downloaded.	Contact your Condair representative.
W163	E163	Per. Supply 5V	Peripheral 5V supply out of valid range! Note: If the value of the peripheral 5V supply is still out of range after a preset period of time after the warning message has appeared, an error is triggered. The Condair RO-E(+) pure water system stops operation and the water system including the pressure tank is emptied.	
			Peripheral 5 V supply out of valid range.	
			5V supply interrupted.	Contact your Condair representative.
			Overload on external connection.	
W164	E164	Ext. Supply 24V	External 24 V supply out of valid range! Note: If the value of the external 24V supply is still out of range after a preset period of time after the warning message has appeared, an error is triggered. The Condair RO-E(+) pure water system stops operation and the water system including the pressure tank is emptied.	
			Short circuit on external connection.	Contact your Condair representative.
			Overload on external connection.	
W165	—	USB Data Logger Definition missing	USB data logger definition file not found on device.	
			The definition file for the USB data logger is missing.	Contact your Condair representative.
W166	—	Error Analyzer Definition missing	Error analyzer definition file not found on device.	
			The definition file for the error analyzer is missing.	Contact your Condair representative.

8.4 Malfunctions without indication

The following table presents malfunctions that do not trigger an error message, together with indications on their cause and notes on how to eliminate the sources of trouble

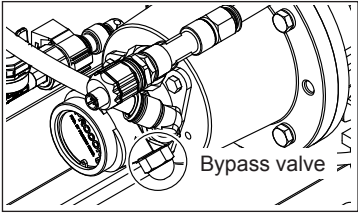
Failure	Cause	Remedy
Water or water residue on the floor panel.	Screw connections and sealing elements not installed correctly or defective.	Install or replace screw connections and sealing elements correctly.
Maximum RO water output is not reached	Membrane(s) was not replaced according to the maintenance interval.	Have membrane(s) replaced by your Condair representative.
	The drain and recycle throttle valves are not set correctly, which causes the system to become calcified more quickly.	Have the throttle valves adjusted by your Condair representative. Have the system decalcified by your Condair representative. If necessary, have the membrane(s) replaced by your Condair representative.
	System was not descaled according to the maintenance interval.	Have the system decalcified by your Condair representative.
	System incorrectly designed (output too low).	Contact your Condair representative
Membrane pressure does not reach the required pressure or the required permeate flow is not achieved.	The pump bypass valve is not completely closed.	To deactivate the pump bypass valve, screw it in clockwise until it stops. 

8.5 Saving fault and service histories to a USB stick

The fault and service histories of the Condair RO-E(+) pure water system can be saved to a USB stick for logging and further analysis. For this purpose, proceed as follows:

Note: To save the fault and service histories of the Condair RO-E(+) pure water system via the control software of the humidifier of an integrated system (e.g. Condair RS) please refer to operation manual of the corresponding humidifier.

1. Set the **<On/Off>** switch on the right side of the Condair RO-E(+) pure water system to the "OFF" position.
2. Carefully insert FAT32 formatted USB stick into the USB port of the external control unit.
3. Set the **<On/Off>** switch on the right side of the Condair RO-E(+) pure water system to the "ON" position.
4. When the home screen appears on the external control unit:
 - Select "**Menu > Password: 8808 > Maintenance > Histories > Export Error/Warning History**". The last 80 events are then downloaded to the USB stick as separate .csv file (Automatically generated file name: "ExceptionHistory_<DeviceType>_<Serial#>_<Date>_<Time>.csv").
 - Select "**Menu > Password: 8808 > Maintenance > Histories > Export Maintenance History**". The last 20 events are then downloaded to the USB stick as separate .csv file (Automatically generated file name: "ServiceHistory_<DeviceType>_<Serial#>_<Date>_<Time>.csv").
5. Set the **<On/Off>** switch on the right side of the Condair RO-E(+) pure water system to the "OFF" position, then remove the USB stick from the external control unit.
6. Set the Condair RO-E(+) pure water system into operation as described in [Section 5.1](#).

8.6 Resetting malfunction indication

To reset the malfunction indication, proceed as follows:

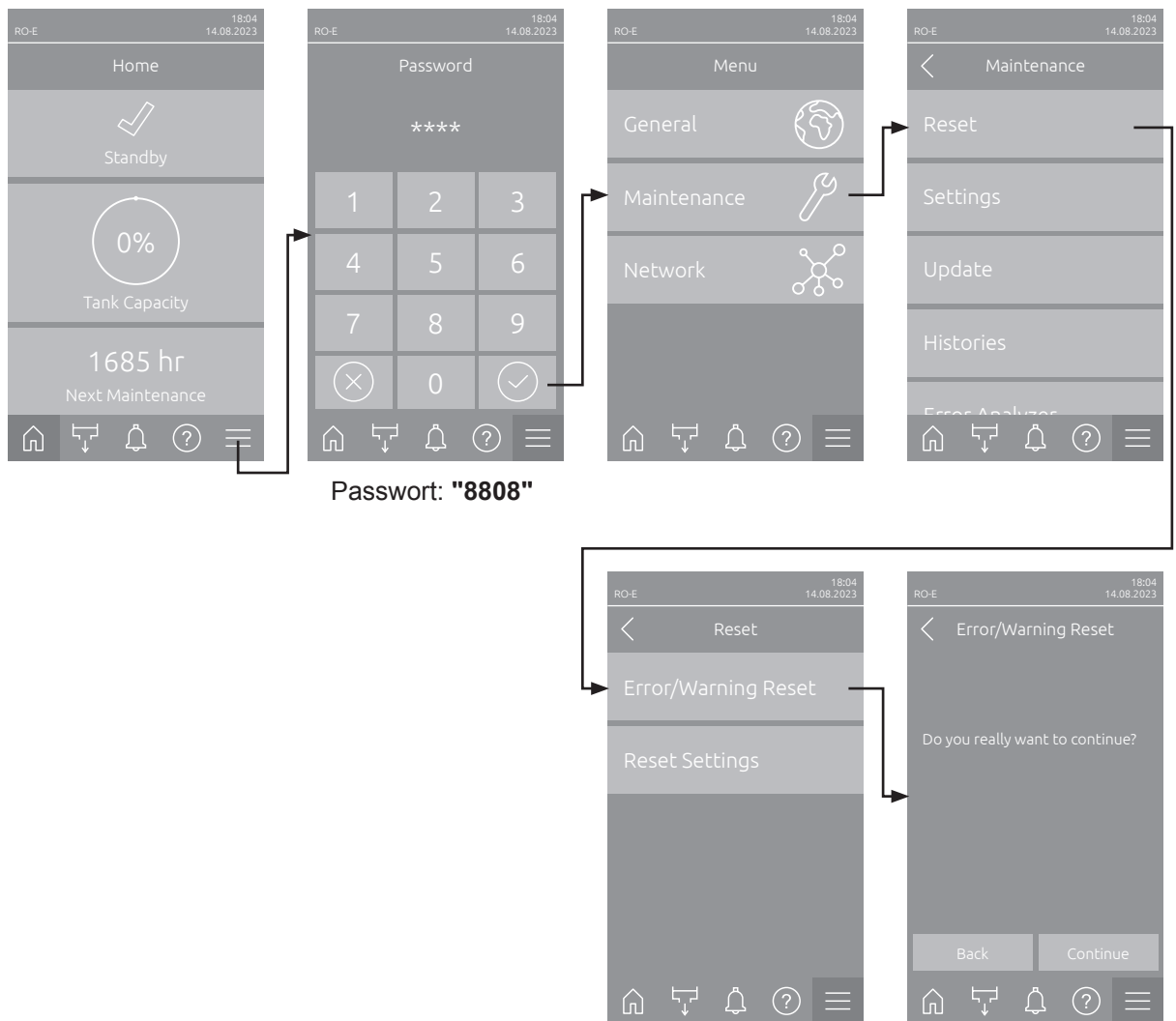

1. Select in the "Error/Warning Reset" function (Path: "Menu > Password: 8808 > Maintenance > Reset > Error/Warning Reset").
2. The reset confirmation dialog appears:
 - Press the **<Continue>** button to reset the malfunction indication(s).
 - Press the **<Back>** button to abort the reset procedure. The control unit returns to the "Reset" submenu.

If the malfunction indication cannot be reset via the control software (e.g., the display hangs), proceed as follows to reset the malfunction indication(s):

1. Switch off the Condair RO-E(+) pure water system via the **<On/Off>** switch (on the right side of the unit).
2. Wait 10 seconds, then switch the Condair RO-E(+) pure water system back on via the **<On/Off>** switch.

Note: If the cause of the malfunction(s) has/have not been eliminated, the malfunction indication(s) reappear(s) after a short while.

9 Taking out of service/Disposal

9.1 Taking out of service

If the Condair RO-E(+) pure water system must be replaced or if the Condair RO-E(+) pure water system is not needed any more, proceed as follows:

1. Take the Condair RO-E(+) pure water system out of operation as described in [Section 5.3](#).
2. Have the system components unmounted by a qualified service technician.

9.2 Disposal/Recycling

Components not used any more must not be disposed of in the domestic waste. Please dispose of the individual components in accordance with local regulations at the authorized collecting point.

If you have any questions, please contact the responsible authority or your local Condair representative.

Thank you for your contribution to environmental protection.

CONSULTING, SALES AND SERVICE:



CH94/0002.00

Condair Group AG
Gwattstrasse 17, 8808 Pfäffikon SZ, Switzerland
Phone +41 55 416 61 11, Fax +41 55 588 00 07
info@condair.com, www.condairgroup.com

The Condair logo, consisting of a stylized wave symbol followed by the word 'condair' in a bold, lowercase, sans-serif font.