



INSTALLATION MANUAL

Steam humidifier
Condair **RS II**

Unit Mounting

Locating the unit

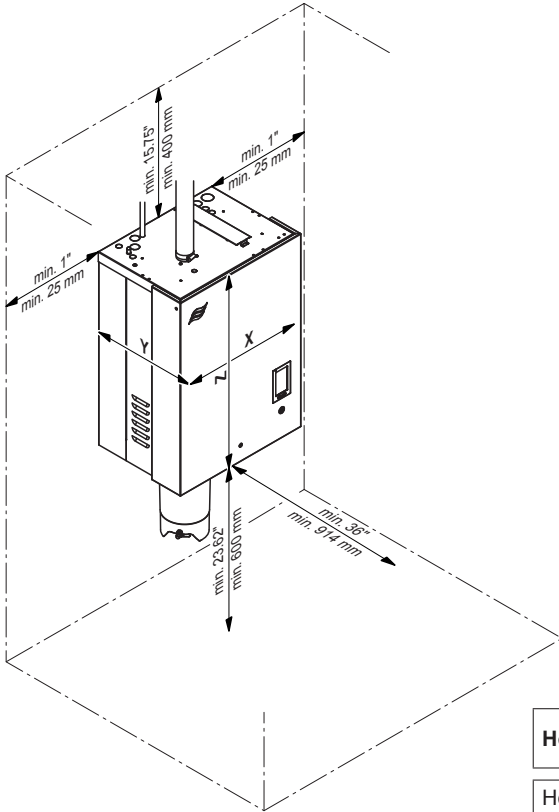

- Install the steam humidifier so that the minimum bend radius of $R= 12"$ / 300 mm for Condair steam hoses or $R= 5 \times$ internal diameter for solid steam pipes and the minimum upslope 10° / downslope 2° of the steam line is maintained.
- Use $1/4 \times 2"$ lag bolts and washers to mount the humidifier onto wooden studs (or equivalent).
- The back panel of the Condair RS retains heat during operation (max. surface temperature of the metal housing approx. $140 - 158^\circ\text{F}$ / $60 - 70^\circ\text{C}$). Make sure, therefore, that the construction (wall, pillar, etc.) to which the unit is to be mounted, does not consist of heat-sensitive material.
- Install the steam humidifier in such a manner that it is freely accessible with sufficient space available for maintenance purposes. The minimum distances shown in the adjacent illustration must be maintained.
- The Condair RS is protected according to IP21. As a safeguard, the humidifier should be installed in a drip-proof location. Admissible ambient conditions must be complied with.
- Do **not** mount the Condair RS to hot or very cold walls or near vibrating components.

Housing		Small ("S") RS 10...20	Medium ("M") RS 30...90	Large ("L") RS 90...180
Housing dimensions in inch (mm)	X	17.8" (453)	22.2" (563)	40.7" (1033)
	Y	14.6" (370)	16.0" (406)	16.0" (406)
	Z	26.4" (670)	30.7" (780)	30.7" (780)
Net weight in lbs (kg)		63 (28.5)	92 (41.5)	185 (83.5)
Operating weight in lbs (kg)		92 (41.5)	148 (67.0)	297 (134.5)

Mounting the unit

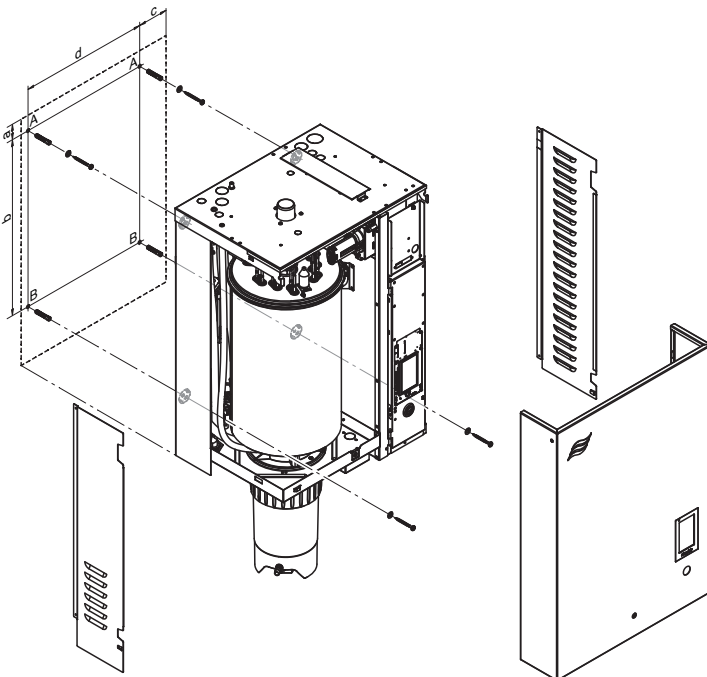

1. Mark the attachment points "A" and "B" at the desired position in the mounting surface with the help of a level.
2. **Mounting on 2x4 wooden studs (or equivalent):** Screw $1/4 \times 2$ in lag bolts and washers at attachment points "A" into the wooden studs. Allow the heads of the bolts to extend $1/4$ in (5 mm) from the mounting surface so that the humidifier can be hung on the bolts.
Mounting on concrete wall: Drill holes with appropriate diameter and depth into the concrete wall at attachment points "A" and "B". Insert appropriate dowels. Then screw $1/4 \times 2$ in lag bolts and washers into the dowels at attachment points "A". Allow the heads of the bolts to extend $1/4$ in (5 mm) from the mounting surface so that the humidifier can be hung on the bolts.
3. Unlock the screw(s) of the front panel(s) of the unit, then remove the front panel(s).
4. Remove side panels on both sides of the unit: Pull side panels to the front then downwards.
5. Carefully raise the unit and hang it on the installed lag bolts.
6. Install additional $1/4 \times 2$ in lag bolts and washers through the rear panel of the humidifier into the mounting surface (2x4 wooden stud or concrete wall with dowel) at attachment points "B".
7. Align the unit with the help of a level, then tighten the lag bolts.
8. Reattach side panels on both sides of the unit: Push side panels upwards into the clip then push it to back of the unit until it comes to a stop.
9. Reattach the front panel(s) and secure with the screw(s).

Water Installation

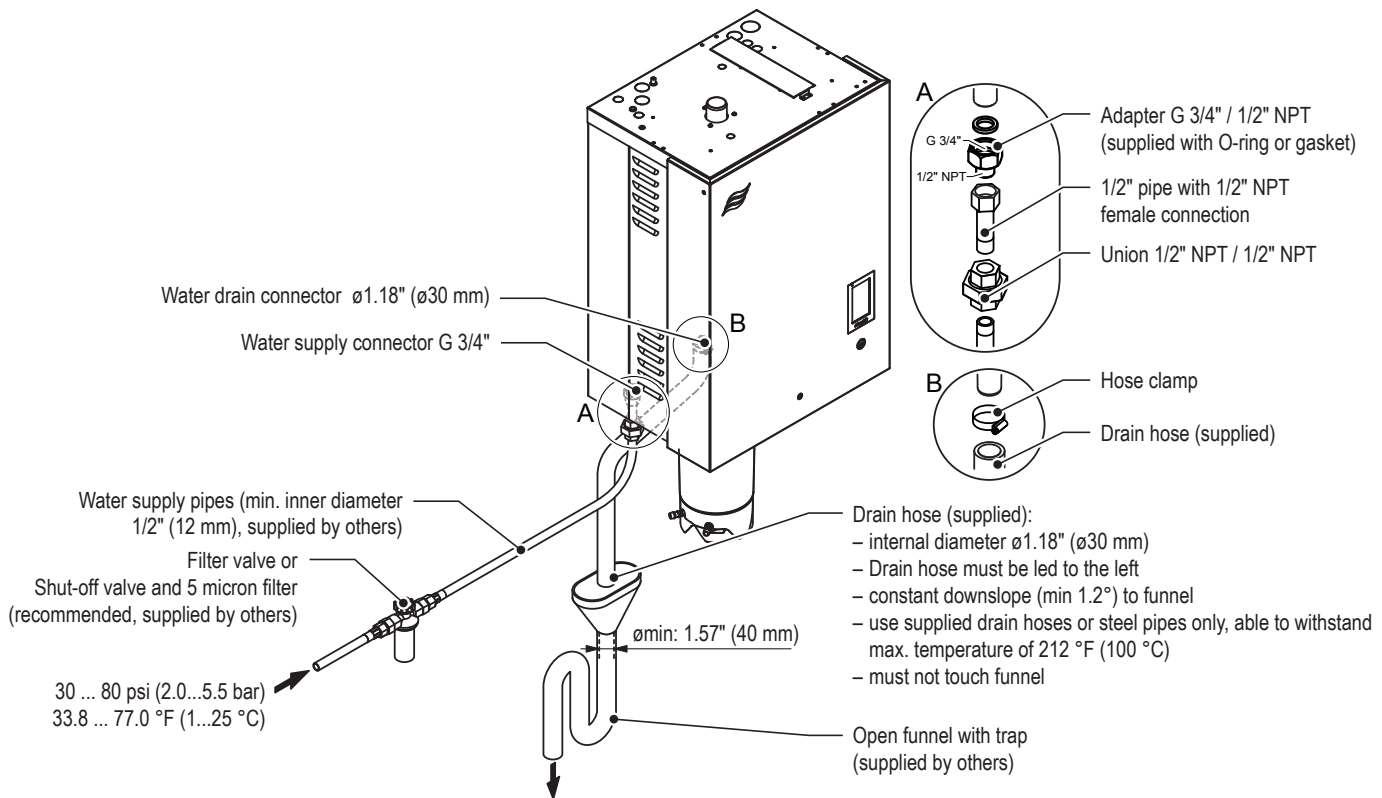

Water Supply

The water supply is to be carried out according to the figure above and the applicable local regulations for water installations. The indicated connection specifications must be observed.

- Admissible water temperature 33.8 to 77.0 °F (1 to 25 °C).
- Admissible mains pressure 30 ... 80 psi (2.1...5.5 bar), hammer free system
- Notes on water quality:
 - For the water supply of the Condair RS, use exclusively untreated drinking water, water from a RO system or de-ionized water.
 - The use of **additives** such as corrosion inhibitors, disinfectants, etc. is **not allowed**, since these additives may endanger health and affect proper operation.
 - Conductivity should be between 1 and 1500 $\mu\text{S}/\text{cm}$. Note that conductivity less than 1 $\mu\text{S}/\text{cm}$ is very aggressive water (this is equivalent to a resistivity of 1 M Ω or greater). It is recommended to blend such water with other less-treated water to ensure the supply is not overly aggressive.
 - Hardness should be between 0 and 12 grains/gallon.
 - Silica content should be between 0 and 12 ppm.
 - pH should be between 6.5 and 7.5.
 - Chloride content should be between 0 and 50 ppm.
- The connection material must be pressure-proof and certified for use with the particular supply water (drinking water, RO or DI water).
- Important! Before connecting the water line(s), the line(s) must be well flushed out.

Water Drain

The water drain is to be carried out according to the figures found in [Section 5.6.1 of the Condair RS Installation Manual \(2611992\)](#) and the applicable local regulations for water installations. The indicated connection specifications must be observed.

- Make sure that the drain pipe(s), the funnel(s) and the siphon(s) are correctly fixed and easily accessible for inspections and cleaning purposes.
- Under normal operation drain water is tempered to 140 °F, however in some circumstances, water as hot as 212 °F may be discharged. Plumbing materials must be rated for at least 212 °F (100 °C)!
- Lead drain line down to the funnel with a constant downslope (min. 1.2°).
Note: On units with two steam cylinders each drain line must be led into a separate funnel with trap.
- Attach drain line(s) in such a way, that it/they cannot slip out of the funnel(s) and that it/they cannot bottom out in the funnel(s).
- The open end of the drain line(s) must not touch the funnel(s) (min. air gap 1" (2.5 cm)).
- We recommend to install the funnel with a lateral off-set of 8" (20 cm) to the side of the unit, to prevent damage to the humidifier due to rising steam.



CAUTION!

The thread at the humidifier connection is made of plastic. To avoid overtightening, the adapter and the union nut of the water pipe must be **tightened by hand only**.

Steam Installation

Installation examples

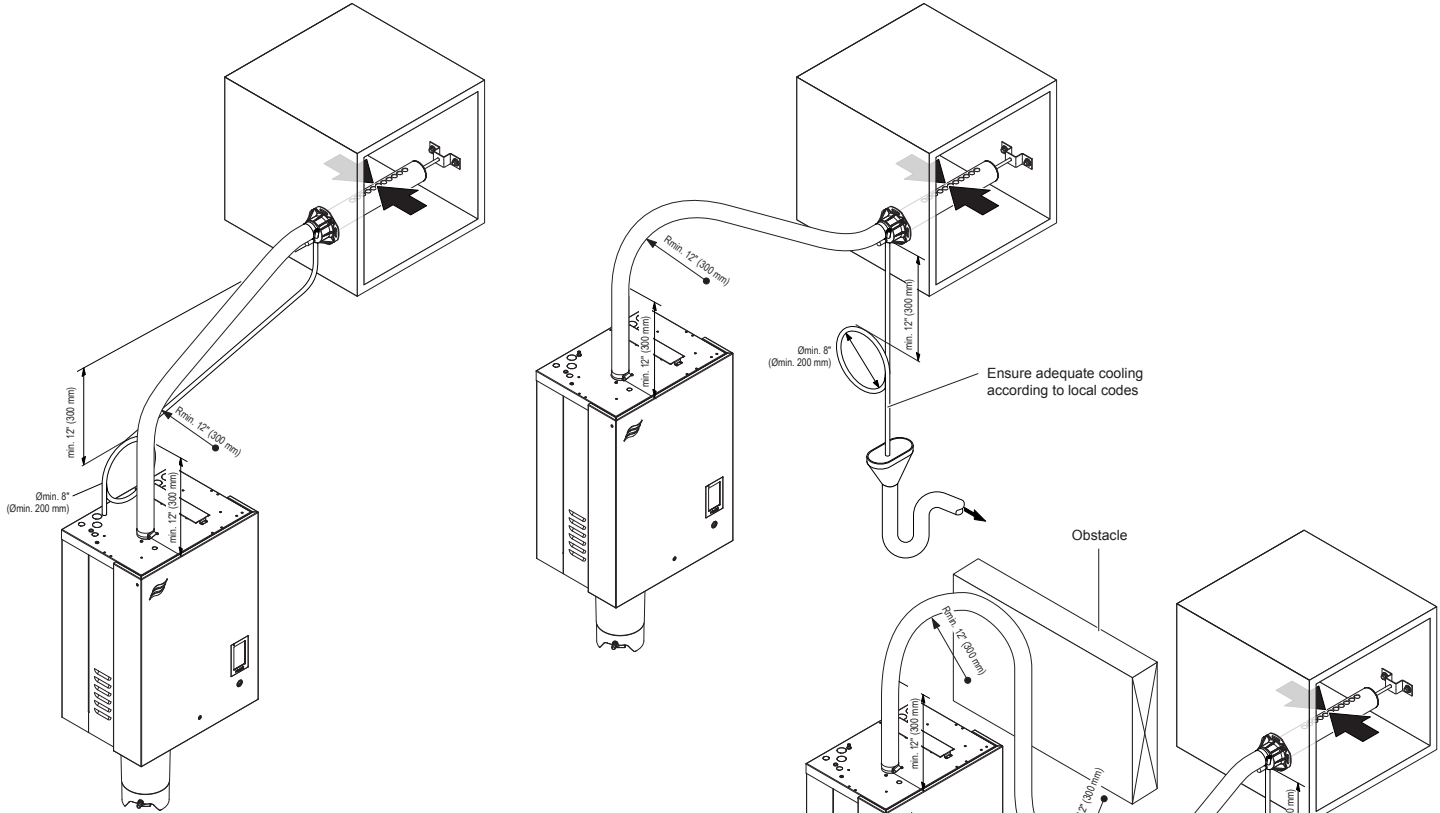

Installation notes

- Use original steam and condensate hose from your Condaire representative or solid steam pipes from copper (MED-L) or stainless steel (min. AISI 304) exclusively. Steam and condensate lines of other material may cause undesired operational malfunctions. For installations with reverse osmosis or de-ionized water supply, do not use copper steam lines.
- Initially, lead the steam line upright upwards min. 12" (300 mm) above the humidifier. Then lead the steam line with a minimum upslope of 10° and/or a minimum downslope of 2° to the steam distributor.
- The condensate hose from the steam distributor is either:
 - led down to the humidifier with a minimum downslope of 1.2°, via a condensate trap (min. hose bend diameter $\varnothing 8''$ ($\varnothing 200$ mm)) and there it is to be connected to the appropriate connector on top of the unit or
 - led down to an open funnel with trap connected to the building drain with a minimum downslope of 1.2°, via a condensate trap (**min. hose bend diameter $\varnothing 8''$ ($\varnothing 200$ mm)**).

Important! Ensure that SAM-e/Mini SAM-e condensate lines, along with any traps from the steam line, are always routed to an open funnel with trap connected to the building drain. Under no circumstances should these condensate lines be connected to the condensate connectors on the unit.

Important! Before putting the unit into operation, the condensate trap of the condensate hose must be filled with water.

- The condensate hose from the steam distributor is led down to the humidifier with a minimum downslope of 1.2°, via a condensate trap (min. hose bend diameter $\varnothing 8''$ ($\varnothing 200$ mm)) and there it is to be connected to the appropriate connector on top of the unit. **Important!** Before putting the unit into operation, the condensate trap of the condensate hose must be filled with water.
- The steam line should be kept as short as possible, as per table 1 from the Condaire RS Installation Manual (2611992). Ensure the minimum bend radii are observed: 12" (300 mm) for steam hoses or 5x internal diameter for solid pipes. **Important!** Allowance must be made for a pressure loss from elbows, according to equivalent length tables.

Install condensate drain (full size T) at the lowest point. Ensure proper slope is maintained for the steam lines upstream and downstream of the T.

- **Important!** When deciding on the length and layout of steam hoses, it should be noted that steam hoses may become shorter and/or longer depending on temperature and age.
- The steam hose must be secured to the steam distributor and humidifier steam outlet by means of hose clamps. Solid steam pipes should be connected to the steam distributor and steam humidifier with short lengths of steam hose secured with hose clamps. **Caution!** Do not overtighten the hose clamp on the steam connector of the steam humidifier.
- Steam lines made of solid pipes (copper or stainless steel) must be insulated over the entire length to minimize condensate formation. Condensate created due to thermal loss in steam lines will reduce the operational efficiency of the humidification system and reduce the moisture supply to the conditioned environment.
- Reducing the cross section or the complete closure of the steam line will cause an excessive increase in pressure in the steam cylinder when the unit is operating and could lead to the risk of scalding accidents. All installations must comply with the following instructions.
 - Ensure steam line is open (no reduction in cross section) along the entire length after installation.
 - Steam hoses must not sag or else condensate may accumulate in low points.
 - **Valves in the steam lines are not permitted.**

Electrical Connection

Wiring diagram

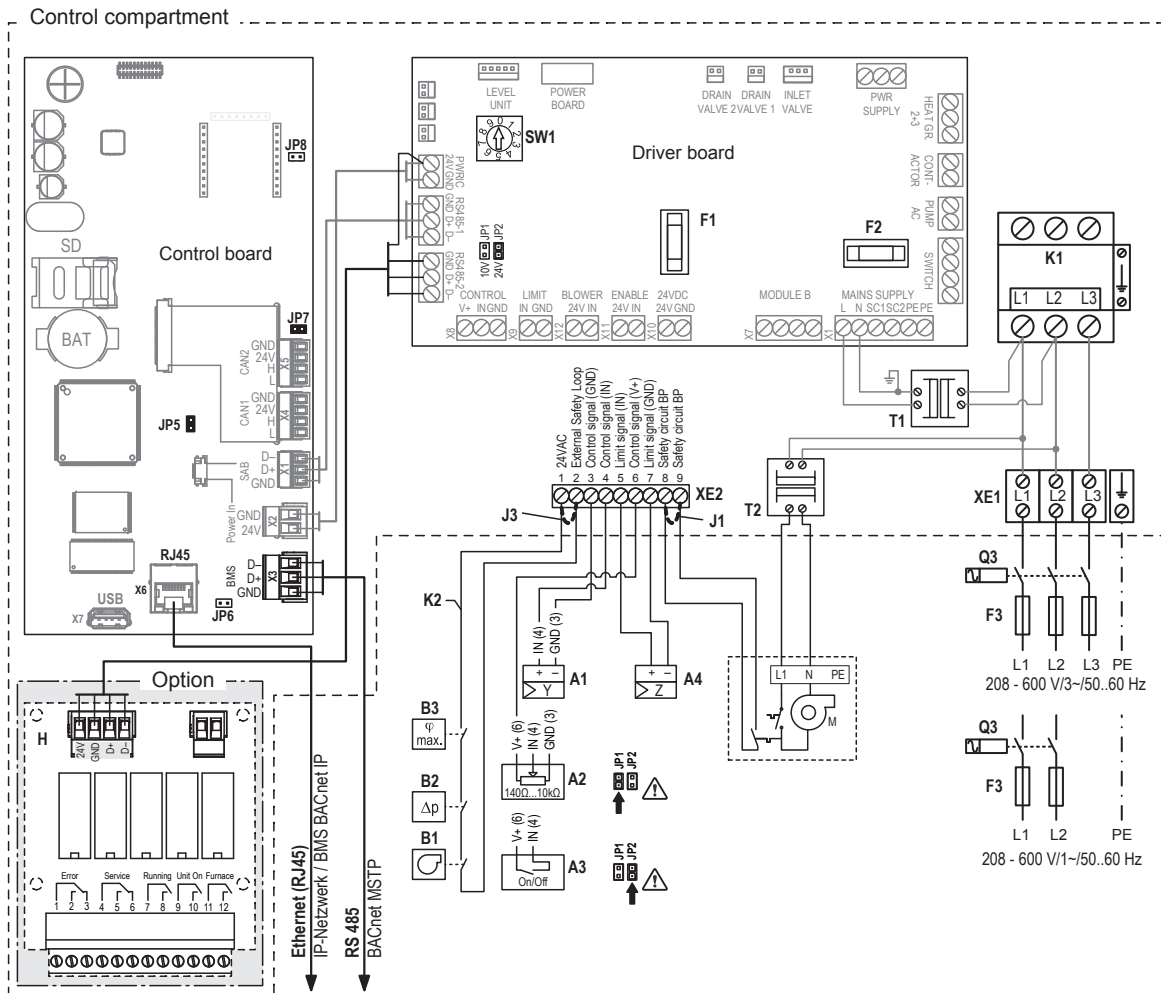

- A1 Continuous humidity controller (active) or humidity sensor
- A2 Ohmic humidity controller (passive), set jumper JP1 and remove jumper JP2
- A3 Dry Contact On/Off Humidity Controller, set jumper JP2 and remove jumper JP1
- A4 Limiter signal
- B1 Ventilation interlock
- B2 Airflow monitor
- B3 Safety humidistat
- F1 Internal fuse 24V supply (1 A, slow acting)
- F2 Internal fuse 24V supply (4 A, slow acting)
- F3 External fuse heating voltage supply (see table in [Section 5.8.7 of the Condair RS Installation Manual \(2611992\)](#))
- F5 Internal fuse control module (200 mA, quick acting)
- H Remote operating and fault indication (option)
- J1 Jumper wire, if no blower pack is connected
- J3 Jumper wire, if no monitoring devices are connected to SC1 and SC2
- JP1 Jumper **connected** = 10V on X8, JP2 no jumper!
- JP2 Jumper **connected** = 24V on X8, JP1 no jumper!
- JP5 Jumper **connected**: Terminating resistor internal communication driver/control board active (**do not remove**)
- JP6 Jumper for activating the terminating resistor for Modbus RTU or BACnet MS/TP communication via the RS485 interface "X3". Jumper must be connected, if Condair RS is the last unit in the Modbus network.
- JP7 Jumper **connected**: Terminating resistor CAN bus active
- JP8 Jumper **removed**: Modbus RTU or BACnet MS/TP communication via RS485 interface "X3"
Jumper **connected**: Communication via optional Gateway board
- K1 Main contactor
- K2 External safety circuit (safety humidistat, airflow monitor, etc.)
- M Motor Blowerpack
- Q3 External main switch heating voltage supply
- SW1 Rotary switch module identification (must be left on position "0")
- T1 Transformer control voltage supply Module A
- T2 Transformer blower pack supply
- XE1 Supply voltage terminal block
- XE2 Control terminal block



All information contained in this Quick Start Installation Guide is for general purposes only. For complete installation recommendations please refer to the installation manual for Condair RS.

All electrical installations must be carried out in accordance with national and local electrical code requirements by a licensed electrician.

All water installations must be carried out in accordance with national and local plumbing code requirements by a licensed plumber.

Condair Ltd. does not accept any liability for any damage caused by faulty installation or the use of components that are not approved by Condair Ltd.

www.condairparts.com

Buy authentic Condair
parts factory direct.

Would you recommend Condair?
Take our two question survey.



U.S.A.
1021 6th Street
Racine, WI 53403

CANADA
2740 Fenton Road
Ottawa, Ontario K1T 3T7

TEL: 1.866.667.8321
EMAIL: na.info@condair.com
WEBSITE: www.condair.com

