

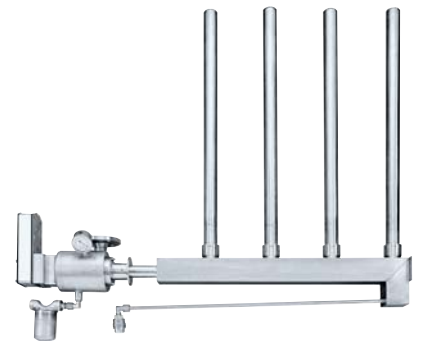

CONDAIR ESCO

Live steam humidifier
With 100% steam tight rotary valve



Condensation-Free Live Steam Humidification

Patented precision nozzles enable condensate-free steam

Inner nozzles draw steam from the middle of the distribution pipe where it is at its hottest and driest. This guarantees that droplets aren't released into the air handling system.



The nozzles are made of robust stainless steel. They are reliable and durable with no fear of leaks.

Standard connection

Standardised flange connections enable simple and safe connection to a steam network.

Rotary disk valve is completely leak proof once closed

The ceramic rotary valve is completely steam tight once closed and won't allow steam leakage to penetrate into the lance or duct. Its design also provides 0-100% modulation delivering very close humidity control.



Primary and secondary condensate drain.

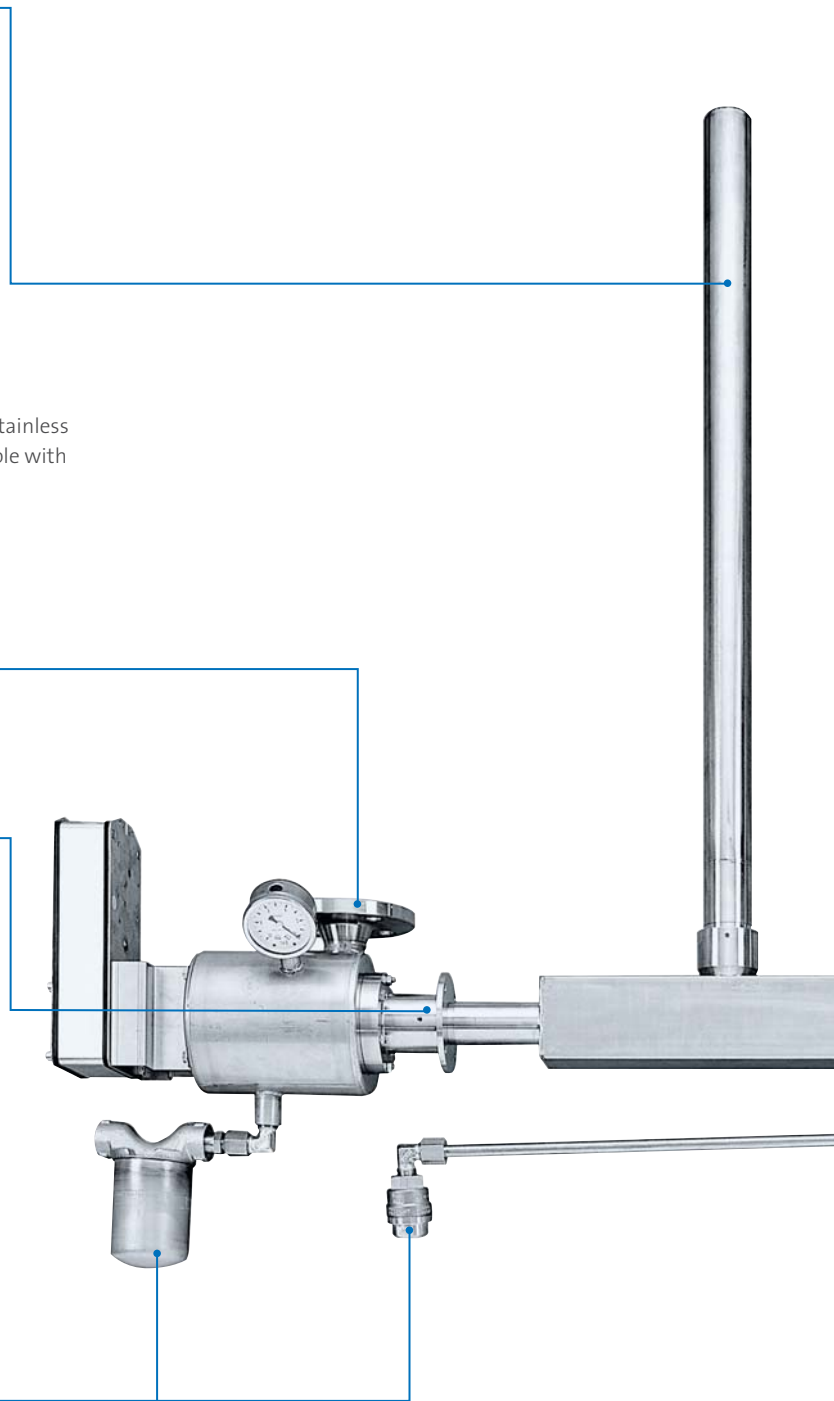

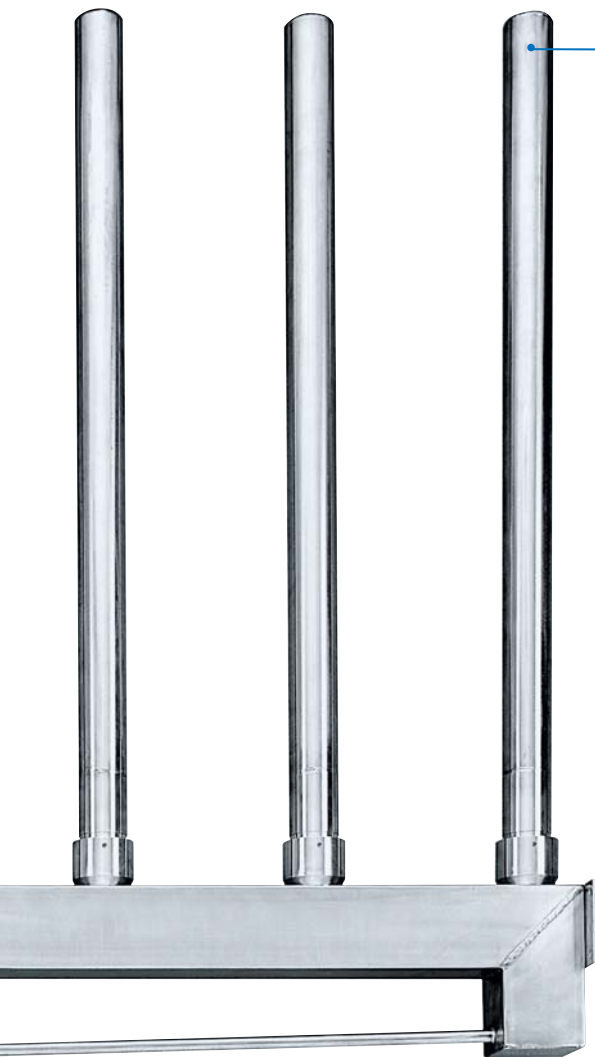

Steam Distribution System

Condair ESCO steam distribution systems with ready fitted connections are built in a modular fashion. With no need for thread sealants on site they are easy to install and leak-free.



Condair ESCO Model: GGG40

Steam connection unit in tried and tested cast iron GGG40 material.



Condair ESCO Model: AISI304

Steam connection unit in stainless steel AISI304 for special requirements on the steam circuit.

Condair ESCO humidifiers set the standard for live steam humidification. Innovative technology and quality construction provide unrivalled performance.

The system can deliver up to 1,000kg/hr of pure, dry steam to an air handling unit or duct using a building's existing steam network of up to 4bar.

It is ideal for use in hospitals, laboratories and manufacturing facilities where there is a ready supply of steam.

The Condair ESCO ceramic rotary disk valve
in open position



The Condair ESCO ceramic rotary disk valve
in closed position

Rotary Disk Valve is Completely Steam Tight When Closed and Offers 0-100% Modulation

The Condair ESCO's ceramic rotary disc valve provides 0-100% modulation and does away with the problems associated with vertical stroke valves. Due to the design, the valve is capable of accurately delivering a linear output throughout the entire regulating range.

When closed the valve is absolutely steam tight and prevents any steam from penetrating into the steam lance when the unit is switched off. This avoids unwanted condensation from occurring after steam leakage.

Minimal torque and optimum reliability

Unlike vertical stroke valves that need to push against the pressure of the steam supply to open, the Condair ESCO's rotary valve requires minimal torque to turn the valve and direct power transmission.

This design is energy efficient and guarantees optimum reliability. It also allows the actuator to be compact.

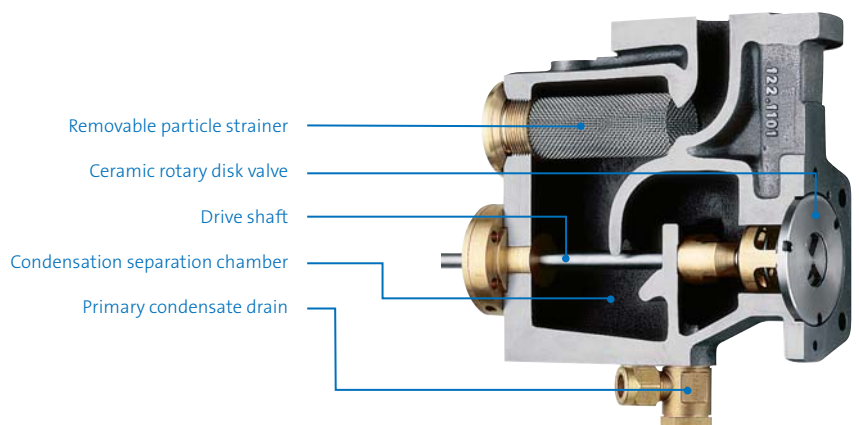



Dry Steam Distribution with Short Evaporation Distance

Short evaporation distances are crucial for reliable and hygienic steam humidification. The steam must never come into contact with components within the air handling unit. This would result in wetting, corrosion and hygiene risks.

Condensate-free steam with patented humidification nozzles

Dry steam delivery is guaranteed by the tiny nozzles that are located inside the Condair Esco's steam lance. The steam is taken only from the centre of the lance, where it is at its hottest and driest. This provides a very short evaporation distance following release into the airstream.

As condensation only gathers around the internal walls of the steam lance, these tiny nozzles prevent condensation from being introduced to the duct.

The condensation that does form inside the lance is safely channelled away by the secondary condensate drain.

Instant humidification

This innovative system eliminates the need to pre-heat the lance with an exterior steam jacket to avoid condensation. Heated steam lances can add up to 4°C to a duct and by removing this element, the Condair Esco saves energy. Also, live steam humidifiers with jacketed steam lances need to reach temperature before steam can be released into the lance. The Condair Esco will start to release condensation-free dry steam on start-up saving time and offering excellent control.

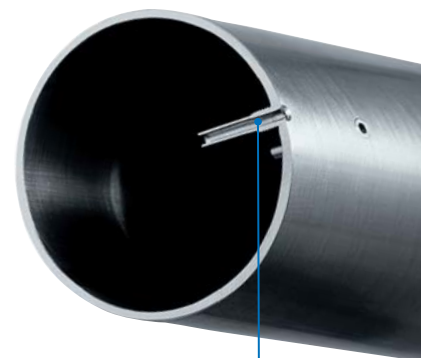

Patented inner nozzles

Customised Solution

The ESCO humidification system offers a choice of steam distribution pipes, depending on the required absorption distance and duct dimensions.

Condair ESCO DL40

With one, two or three horizontal steam distributors the DL40 is flexible and can be adjusted to suit the duct.

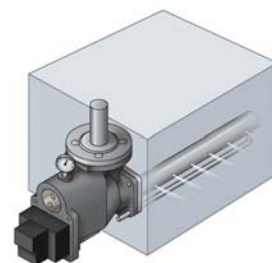

Model:
Condair ESCO DL40

Condair ESCO DR73

For high steam duties or short evaporation distances the DR73 is ideal. The steam distribution system is designed specifically for each project. With nozzles on both sides of the steam pipe, distribution is uniform across the entire duct.

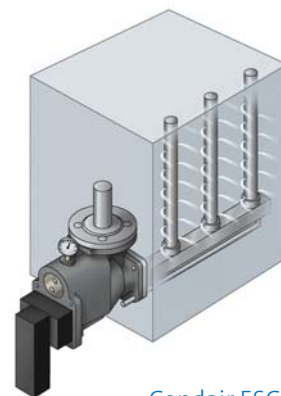

Model:
Condair ESCO DR73

System overview

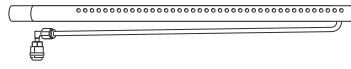

Series DL40 with single pipe distribution

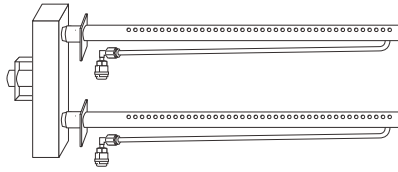

Series DL40 with double pipe distribution

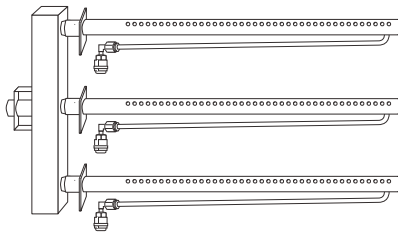

Series DL40 with triple pipe distribution

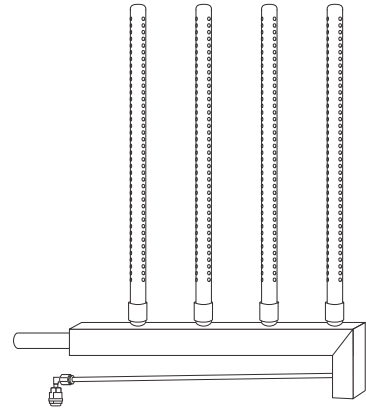

Series DR73 with vertical pipe distribution

Technical Data

Series	Size of valve	Steam pressure	Steam capacity	Width of air duct
		[bar]	max. [kg/h]	max. [mm]
DL40	Esco 5	0.2 – 4.0 bar	127	4,000
	Esco 10	0.2 – 4.0 bar	250	4,000
	Esco 20	0.2 – 4.0 bar	500	4,000
DR73	Esco 10	0.2 – 4.0 bar	250	10,000
	Esco 20	0.2 – 4.0 bar	500	10,000
	Esco 30	0.2 – 4.0 bar	2.000	10,000

Evaporation distances are for guidance only. For exact evaporation distances please contact us.