



JS60C - JETSPRAY COMPACT

Compressed air and water
spray humidifier



Easy to install, direct room humidifier offering up to 66 lb/h of humidification

Fully assembled, easy-to-install

Supplied with two nozzles, as standard, the unit is preassembled and ready for use.

Humidistat with display



Allows the required room humidity to be set and monitored, which in turn controls the output of the humidifier.

Electrical connection

Air connection

Compressed air ensures rapid evaporation of the aerosols, without the risk of drips.

Water supply



PureFlo antibacterial filter, to combat microbial growth, together with a 5 micron particle filter.

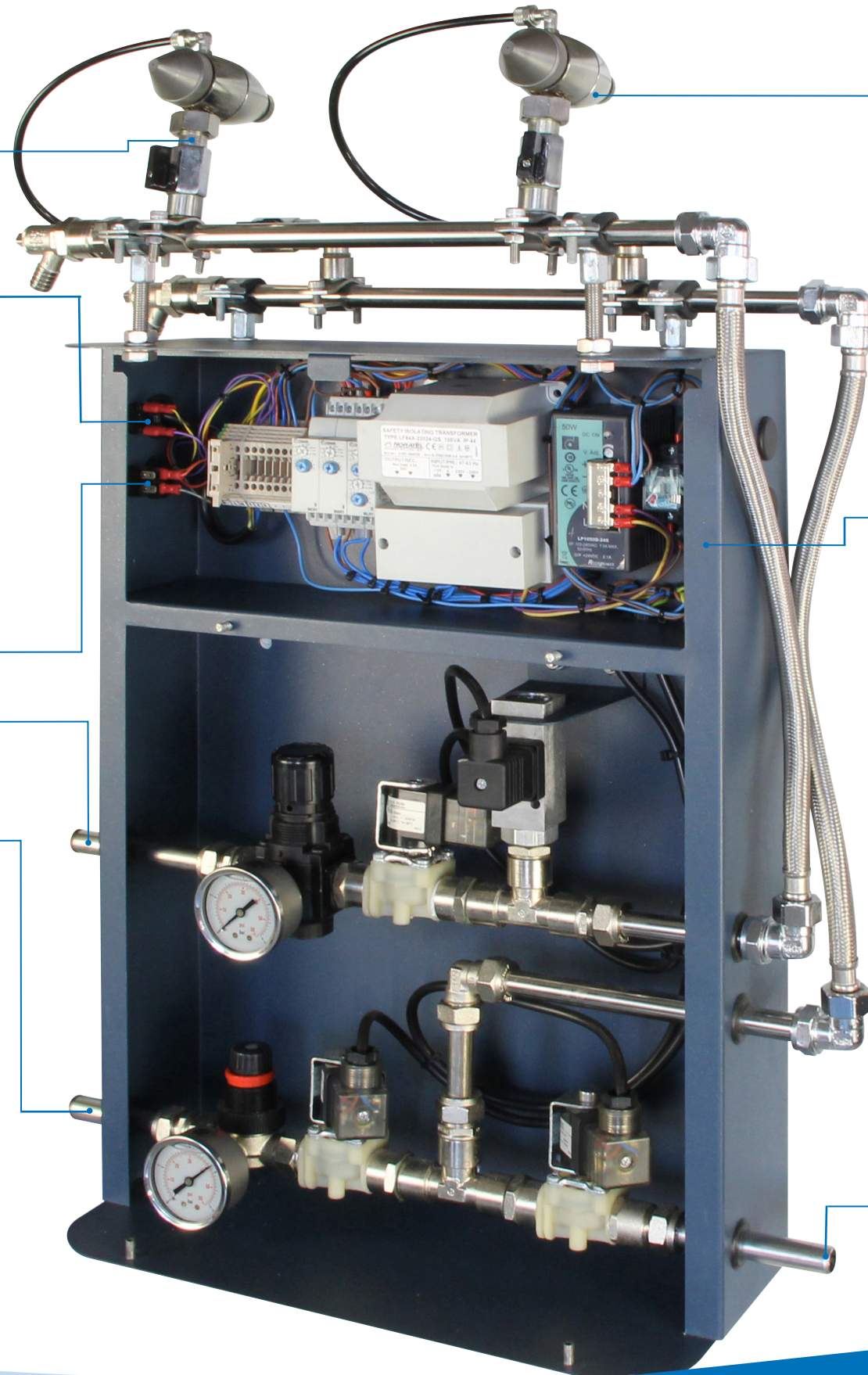

Self-cleaning nozzles



An internal pin prevents blockages, resulting in robust operation in industrial environments. The nozzles come in a variety of outputs and are directionally adjustable, horizontally and vertically.

Cabinet

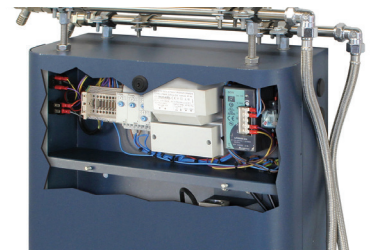

IP54 rated, as standard, with all internals easily accessible for operation and maintenance. The electrical components are mounted in a separate compartment located above the water and air pipes.

Hygiene

Advanced hygiene features include start-up water line purge, daily flush and full drain down of the water lines when not in use.

Drain

JETSPRAY COMPACT

Compressed air and water spray humidifier

The JetSpray Compact is an easy-to-install, direct room humidifier for areas that need up to 66 lb/hr. As it is preassembled, it does not require installation of additional nozzles or

associated pipework. Operation with compressed air gives very reliable operation, in dusty industrial environments, without any risk of drips. This makes the JetSpray Compact ideal for use in sectors such

as textile, tea, food, tobacco and printing. Advanced hygiene features ensure the humidifier provides safe operation. Water treatment and flush and drain cycles minimize the risk of microbial growth in the system.

Typical system overview

- 1 Cabinet (IP54 rated)
- 2 Water supply with optional anti-bacterial filter set
- 3 Compressed air in
- 4 Drain
- 5 Condair CHR humidistat with display (optional)
- 6 Nozzles (x2)

Other options

- Room humidistat
- Booster water pump and tank
- RO water filter

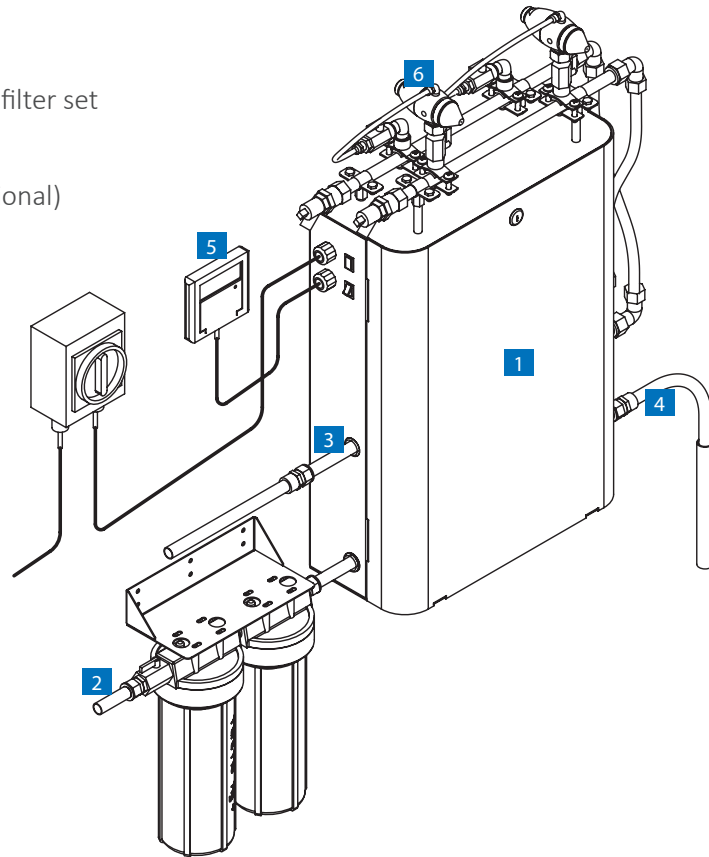

Technical data

	JS60C-11	JS60C-15	JS60C-20	JS60C-24	JS60C-29	JS60C-40	JS60C-53	JS60C-66
Output (lb/hr)	11	15	20	24	29	40	53	66
Humidity control	±4 % RH							
Control	On/Off							
Dimensions	14.9 in x 29.1 in x 6.6 in (WxHxD)							
Weight	40 lb							
Power supply	110/120 V / 60 Hz							
Power consumption	0.17- 0.21 kW				0.7- 0.87 A			

About Condair

Condair Group, founded in 1948 and based in Switzerland, is the global leader in humidification, dehumidification and evaporative cooling. Supported by science, we engineer tailored, holistic solutions that customers can trust. With optimal humidity, we increase productivity and create healthier built environments.

Condair Group has production sites in Europe, North America and China and representatives in 50 locations worldwide. You can rely on our comprehensive portfolio of innovative technologies for air humidification, dehumidification and evaporative cooling to meet the needs of your application.