

BACnet, LonWorks

Supplemental Installation and Operation Manual

For use with RS, EL, DL, and
ME humidifiers with
Software version 5.7.x.x

Thank you for choosing Condair

Installation date (MM/DD/YYYY):

Commissioning date (MM/DD/YYYY):

Site:

Model:

Serial number:

Contact

Condair Ltd.
2740 Fenton Road, Ottawa, Ontario K1T3T7
TEL: 1.866.667.8321, FAX: 613.822.7964
EMAIL: na.info@condair.com, WEBSITE: www.condair.com

Proprietary Notice

This document and the information disclosed herein are proprietary data of Condair Ltd. Neither this document, nor the information contained herein shall be reproduced, used, or disclosed to others without the written authorization of Condair Ltd., except to the extent required for installation or maintenance of recipient's equipment.

Liability Notice

Condair Ltd. does not accept any liability due to incorrect installation or operation of the equipment or due to the use of parts/components/equipment that are not authorized by Condair Ltd.

Copyright Notice

© Condair Ltd., All rights reserved.

Technical modifications reserved

Contents

1	Introduction	5
1.1	Notes on this addendum manual	5
1.2	Functions overview	6
2	For your safety	7
3	Network integration via BACnet on-board	9
3.1	Notes for the planning engineer	9
3.1.1	Overview	9
3.1.2	Principle network diagrams	10
3.1.2.1	Principle BACnet network	10
3.2	Wiring	12
3.3	Configuration	13
3.3.1	Configuring the Condair Integrated Controller (software version 5.7.x.x)	13
3.3.1.1	Setup the communication parameters	13
3.3.1.2	Setup control settings	17
3.3.1.3	Monitoring of bus communication from software version 5.7.x.x:	17
3.4	Communication tables	18
3.4.1	DL - BACnet on-board (Integrated Controller Software version 5.7.x.x)	18
3.4.2	ME - BACnet on-board (Integrated Controller software version 5.7.x.x)	20
3.4.3	RS - BACnet on-board (Integrated Controller software version 5.7.x.x)	23
3.5	Operating trouble list	27
4	Network integration via the optional LonWorks and BACnet Gateway boards	30
4.1	Notes for the planning engineer	30
4.1.1	Overview	30
4.1.2	Principle Network diagrams	31
4.1.2.1	Principle BACnet network	31
4.1.2.2	Principle LonWorks network	33
4.2	Installation work	34
4.2.1	Installing the BACnet/LonWorks gateway board on the Integrated Controller	34
4.2.2	Wiring	35
4.3	Configuration	36
4.3.1	Configuring the Condair Integrated Controller (software version 5.7.x.x)	36
4.3.1.1	Setup control settings	36
4.3.1.2	Monitoring of bus communication from software version 5.7.x.x:	37
4.3.1.3	BMS Timeout and Modbus settings	38
4.3.2	Gateway configuration	39
4.3.2.1	Requirements for gateway configuration	39
4.3.2.2	Configure the IP settings	40
4.3.2.3	Modifying the BACnet gateway configuration	42
4.4	Communication tables	45
4.4.1	DL - BACnet (Integrated Controller software version 5.7.x.x)	45
4.4.2	DL - LonWorks (Integrated Controller software version 5.7.x.x)	47
4.4.3	ME - BACnet (Integrated Controller software version 5.7.x.x)	49
4.4.4	ME- LonWorks (Integrated Controller software version 5.7.x.x)	52
4.4.5	RS - BACnet (Integrated Controller software version 5.7.x.x)	55
4.4.6	RS - LonWorks (Integrated Controller software version 5.7.x.x)	59

4.5	Troubleshooting	63
4.5.1	Operating trouble list	63
4.5.2	LED functions	66
5	Appendix	69
5.1	Object abbreviations	69
6	Ordering form	70

1 Introduction

1.1 Notes on this addendum manual

Condair devices equipped with an Integrated Controller can either be connected via the corresponding interface on the Integrated Controller (BACnet on-board) to a BACnet IP network or a BACnet MS/TP network or via the optional LonWorks or BACnet gateway boards (ProtoCessor gateway) to a LonWorks, BACnet IP or BACnet MS/TP network to a building management system.

This manual describes how to install and configure BACnet on-board (see [chapter 3](#)) and the optional LonWorks and BACnet gateway boards (see [chapter 4](#)) to connect the corresponding Condair devices to a building management system.

This addendum manual is intended for use by engineers and properly trained technical personnel. Please read this manual thoroughly before installing and configuring the BACnet or LonWorks based network.

If you have questions after reading this documentation, please contact your Condair representative. They will be glad to assist you.

Symbols used in this manual



CAUTION!

The catchword "CAUTION" used in conjunction with the caution symbol in the circle designates notes in this manual that, if neglected, may cause **damage and/or malfunction of the unit or other material assets**.



WARNING!

The catchword "WARNING" used in conjunction with the general caution symbol designates safety and danger notes in this manual that, if neglected, may cause **injury to persons**.



DANGER!

The catchword "DANGER" used in conjunction with the general caution symbol designates safety and danger notes in this manual that, if neglected, may lead to **severe injury or even death of persons**.

Safekeeping

Please safeguard this addendum manual in a safe place, where it can be immediately accessed. If the equipment changes hands, the documentation must be passed on to the new operator.

If the documentation gets mislaid, please contact your Condair representative for replacement.

Language versions

This addendum manual is available in various languages. Please contact your Condair representative for information.

1.2 Functions overview

The following table gives you an overview of the supported protocols and functions.

	BACnet on-board Integrated controller	Optional BACnet Gateway board	Optional LonWorks Gateway board
BACnet IP and BACnet MS/TP BTL certified	no	yes	no
BACnet IP	yes	yes	no
BACnet MS/TP Master Mode	yes	yes	no
BACnet MS/TP Slave Mode	yes	yes	no
LonWorks certified	no	no	yes
Remote"RS draining"	no	yes	yes
BACnet Service COV (Change of Value)	no	yes	no

Please refer to the BACnet Protocol Implementation Conformance Statement (PICS) and the objects tables for detailed information.

2 For your safety

General

Every person working with the Condair Integrated Controller must have read and understood this addendum manual, and the installation manual and operation manual of the Condair Integrated Controller, before carrying out any work.

Knowing and understanding the contents of the manuals is a basic requirement for protecting the personnel against any kind of danger, to prevent faulty operation, and to operate the unit safely and correctly.

All icons, signs and markings applied to the unit must be observed and kept in readable state.

Qualification of personnel

All work described in this addendum manual **may only be carried out by specialists who are well trained and adequately qualified and are authorised by the customer.**

For safety and warranty reasons any action beyond the scope of this manual must be carried out only by qualified personnel authorised by the manufacturer.

It is assumed that all persons working with the Condair Integrated Controller are familiar and comply with the appropriate local regulations on work safety and the prevention of accidents.

Intended use

The optional LonWorks or BACnet gateway boards are intended exclusively for connecting the Condair Integrated Controller to a LonWorks or BACnet based network. Any other type of application, without the written consent of the manufacturer, is considered as not conforming with the intended purpose and may lead to the Condair Integrated Controller becoming dangerous.

Operation of the equipment in the intended manner requires **that all the information contained in this addendum manual as well as in the installation manual and operation manual of the Condair Integrated Controller are observed.**

Danger that may arise from the Condair Integrated Controller



DANGER!
Risk of electric shock!

The electrical compartment where the Integrated Controller is located may have live mains voltage connected for other uses of the device. Live parts may be exposed when the control unit is open. Touching live parts may cause severe injury or danger to life.

Prevention: Before commencing any work on the control unit disconnect the mains supply voltage to the humidifier via the electrical isolator in the mains supply line, and secure electrical isolator in "Off" position against inadvertent switching on.

Safety reporting

All persons working with the Condair Integrated Controller are obliged to report any alterations to the system that may affect safety to the owner without delay and to **secure such systems against accidental power-up**.

Prohibited modifications to the unit

No modifications must be undertaken on the optional LonWorks or BACnet gateway boards and on the Condair Integrated Controller without the express written consent of the manufacturer.

For the replacement of defective components use exclusively **original accessories and spare parts** available from your Condair representative.

3 Network integration via BACnet on-board

3.1 Notes for the planning engineer

3.1.1 Overview

The BACnet on-board functionality of the Integrated Controllers allows to connect Condair devices via the RJ45 Ethernet interface to a BACnet network or via the RS485 interface to a BACnet MS/TP network without further options.

The following protocol options are available as standard from software version 5.7.x.x:

Interface on the Integrated Controller	Protocol	Description
RJ45 Ethernet port	BACnet IP	BACnet IP
RS485 interface	BACnet MS/TP	BACnet MS/TP Master or Slave Mode

Please refer to the BACnet object or Lonworks SNVT tables in [chapter 3.4](#) for detailed information regarding the available read out and settings functions.

3.1.2 Principle network diagrams

3.1.2.1 Principle BACnet network

The principle diagram below shows the connection of the Condair Integrated Controller to an Ethernet network.

Principle BACnet IP network



Abb. 1: Principle BACnet IP network

Principle BACnet MS/TP network

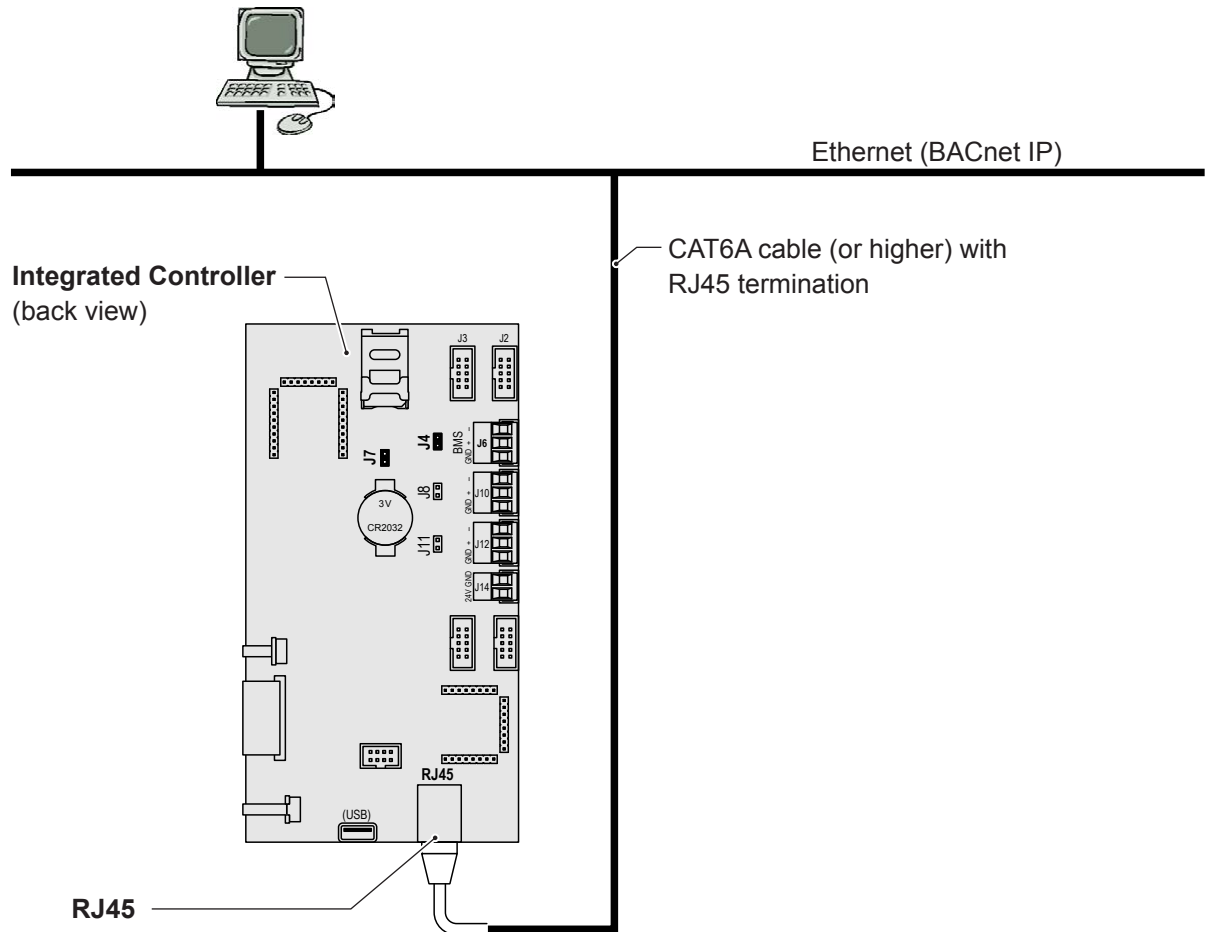

Abb. 2: Principle BACnet MS/TP network

3.2 Wiring

1. Lead the network cable through a cable gland or the rectangular cable lead-through into the control unit.
2. Connect network cable according to the following wiring diagrams to the corresponding interface connector on the Integrated Controller.

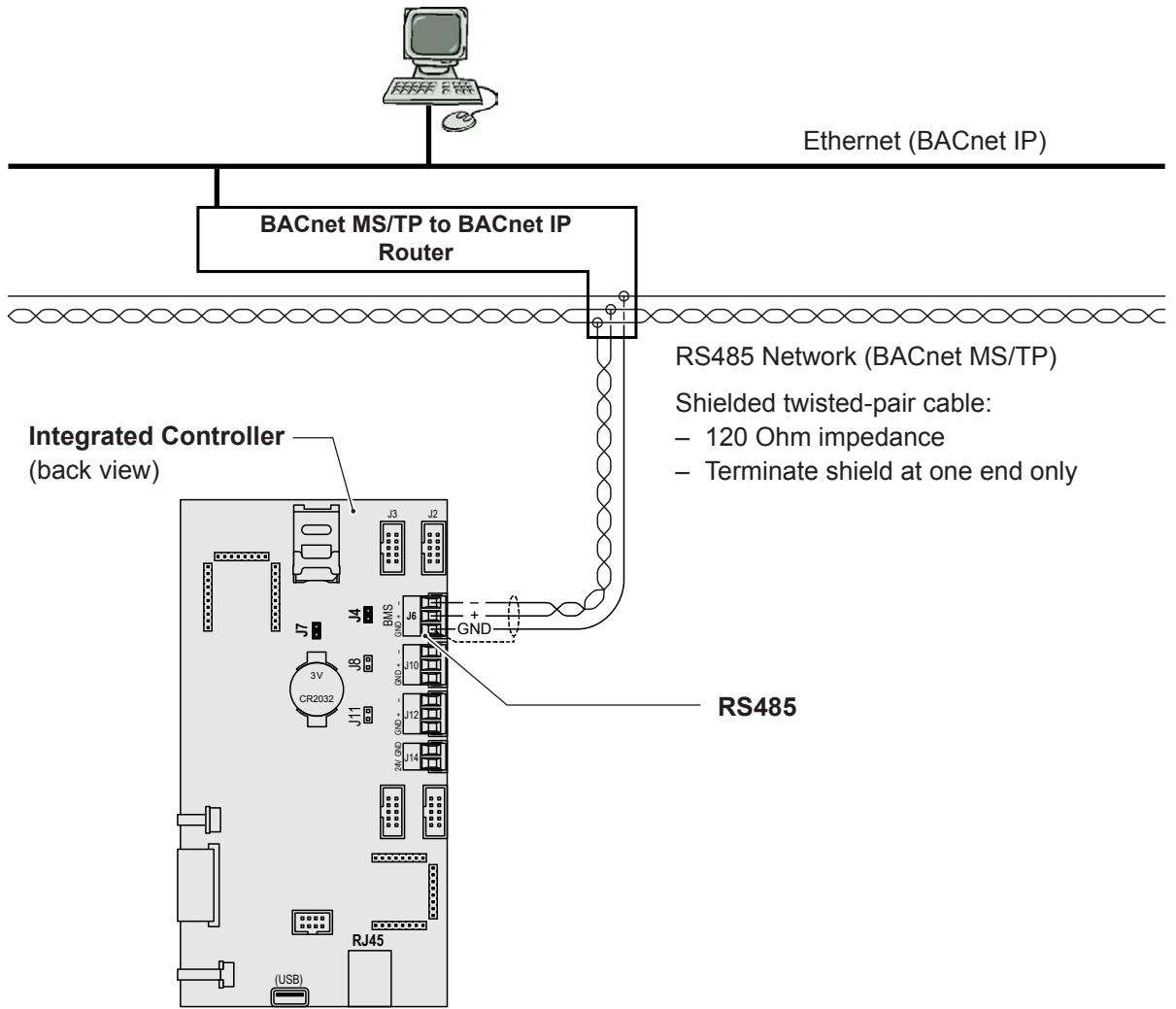
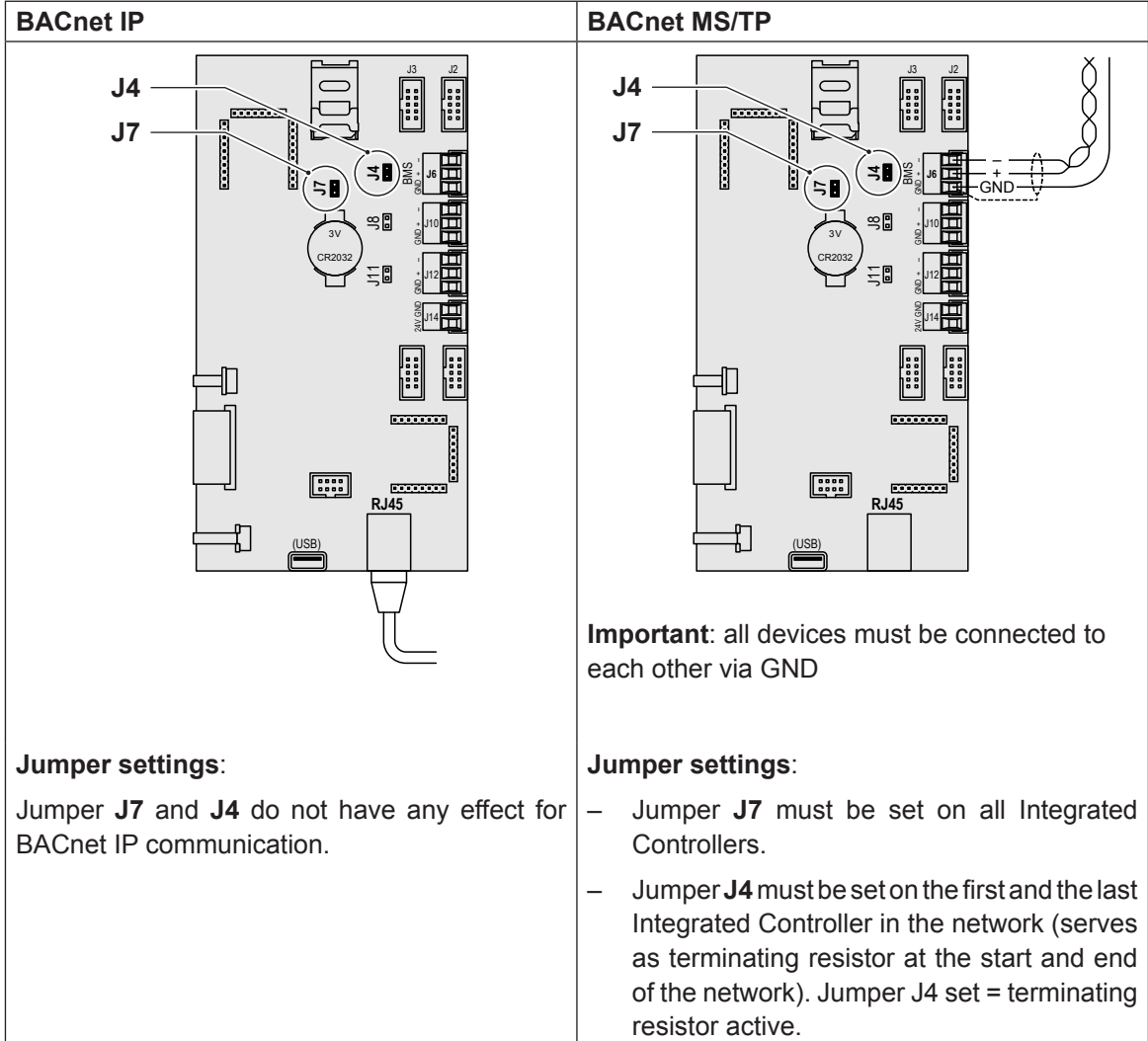

3.3 Configuration

After network wiring connections have been completed, the Condair Integrated Controller needs to be setup to operate and communicate through BACnet IP or BACnet MS/TP with the building management system. This setup includes the settings in the " **Communication**" and the " **Control Settings**" submenu of the Condair Integrated Controller.

3.3.1 Configuring the Condair Integrated Controller (software version 5.7.x.x)

3.3.1.1 Setup the communication parameters

Select "Communication" submenu submenu as shown below.



Then setup the communication parameters in the corresponding tabs listed below.

Network Parameters Tab

The following network settings are used only for the communication via the integrated BACnet IP interface.



- **IP Type:** with this setting you determine whether you want to assign the IP Address, the Subnet Mask, the Standard Gateway as well as the Primary and Secondary DNS address as fixed values or whether these should be dynamically assigned via a DHCP server.
Note: after 5 unsuccessful attempts at obtaining an address with DHCP the system will revert to fixed assignment
Factory setting: **DHCP**
Options: **DHCP** (dynamic assignment)
Fixed (fixed assignment)
- **IP Address:** with this setting you manually enter the IP Address of the device.
Note: This IP Address is used if "IP Type" is set (or reverts) to "Fixed".
- **Subnet Mask:** with this setting you determine the Subnet Mask of the IP network.
Note: This Subnet Mask is used if "IP Type" is set (or reverts) to "Fixed".
- **Default Gateway:** with this setting you determine the IP Address of the Default Gateway.
Note: This IP Address for the Default Gateway is used if "IP Type" is set (or reverts) to "Fixed".

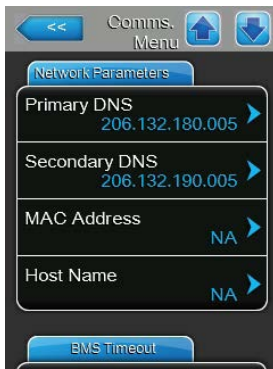

- **Primary DNS:** with this setting you determine the IP Address of the Primary Domain Name Server (DNS).
Note: This IP Address for the Primary Domain Name Server is used if "IP Type" is set (or reverts) to "Fixed".
- **Secondary DNS:** with this setting you determine the IP Address of the Secondary Domain Name Server (DNS).
Note: This IP Address for the Secondary Domain Name Server is used if "IP Type" is set (or reverts) to "Fixed".
- **MAC Address:** factory set MAC Address (Media Access Control) of the device. Not modifiable.
- **Host Name:** Host Name of the device automatically generated by the control. Format: "IC_"+"Serial number of the device". Not modifiable.

BMS Timeout Tab

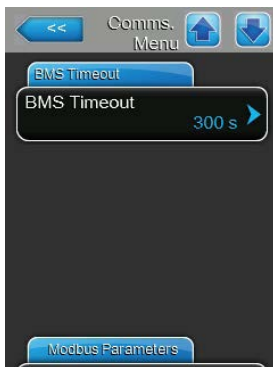

- **BMS Timeout:** with this setting you determine the maximum time the humidifier will wait with no communication from the BMS network before a BMS timeout warning is generated. The humidification is stopped until a valid signal is transmitted again.
Factory setting: **300 s**
Setting range: **1 ... 300 s**

BACnet Parameters Tab



- **BACnet:** with this setting you can activate ("MSTP" or "BACnet/IP") or deactivate ("Off") the communication via the integrated BACnet interface.
Note: For some settings, the device will reboot to apply the changes.
Important! If the demand signal is also to be sent via BACnet, always make sure that the signal source in the submenu "Configuration> Control settings > Source" is set to the same BACnet protocol ("BACnet/IP" or "BACnet/MS"), see [chapter 3.3.1.2](#).
Factory setting: **Off**
Options: **Off** (BACnet interface deactivated)
MSTP (BACnet MS/TP via RS 485 interface)
BACnet/IP (BACnet IP via RJ45 interface)

BACnet IP Settings

The following settings appear only, if the parameter "BACnet" is set to "BACnet/IP".



- **Device Name:** with this setting you determine the name of the device for the communication via the integrated BACnet interface.
Note: The name assigned here is also assigned to the object name of the device object.
- **Device Description:** with this setting you determine a short description of the device.
Note: The device description assigned here is also assigned to the property "Description" in the device object (Property Description).
- **Device Location:** with this setting you determine the designation of the device location.
Note: The location assigned is also assigned to the property "Location" in the device object.
- **Node ID:** with this setting you assign a node ID to the device for the communication over the BACnet IP protocol.
Factory setting: **1001**
Setting range: **1 - 4194303**
- **BACnet IP Port:** with this setting you assign a IP port number for the device.
Factory setting: **47808**
Setting range: **1 - 65535**
- **Foreign Device:** With this setting, you determine whether the device logs in to an external BACnet IP Broadcast Management Device (BBMD) ("On") so that it can receive broadcast messages (messages to all participants) on the IP network or not ("Off").
Note: In an IP network, routers generally block broadcast messages (messages to all participants) to reduce traffic. This prevents a BACnet IP device from being detected via the "Who-is" service, or to answer via the "I-Am" service. In order for the BACnet IP broadcast messages to be forwarded to other network segments anyway, a BBMD (BACnet IP Broadcast Management Device) is required. These devices integrated into the IP network forward BACnet IP broadcast messages to other network segments. Only one BBMD may be integrated per network segment.
Factory setting: **Off**
Options: **Off or On**
- **BBMD IP Address:** With this setting, you specify the IP address of the external BBMD to which the device should log on.

BACnet MS/TP Settings

The following settings appear only, if the parameter "BACnet" is set to "MSTP".

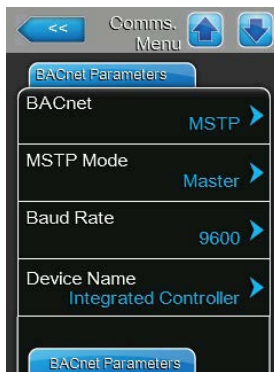

- **MSTP Mode:** with this setting you determine whether the device should act as Master or Slave.
Factory setting: **Master**
Options: **Master or Slave**
- **Baudrate:** with this setting you set the Baudrate for the data transfer.
Factory setting: **9600**
Options: **9600, 19200, 38400, 57600, 76800**
- **Device Name:** with this setting you determine the name of the device for the communication via the integrated BACnet interface.
Note: The name assigned here is also assigned to the object name of the device object.
- **Device Description:** with this setting you determine a short description of the device.
Note: The device description assigned here is also assigned to the property "Description" in the device object (Property Description).
- **Device Location:** with this setting you determine the designation of the device location.
Note: The location assigned is also assigned to the property "Location" in the device object.
- **Node ID:** with this setting you assign a node ID to the device for the communication over the BACnet MS/TP protocol.
Factory setting: **1001**
Setting range: **1 - 4194303**
- **BACnet MSTP MAC:** with this setting you assign a MSTP MAC address for the device.
Factory setting: **127**
Setting range: **0 - 127 (for Master)**
0 - 254 (for Slave)

3.3.1.2 Setup control settings

By default the Condair Integrated Controller is configured to operate on a hardwired analog control signal from an external humidity controller or a humidity sensor (if internal P or PI controller is used) connected to the driver board inside the control unit.

Note: If you want the Condair Integrated Controller to be controlled via a hardwired analog control signal set "Signal Source" to "Analog" and set the other control settings as required (see "Operation Manual" of the corresponding device for details).

If you want to control the Condair Integrated Controller entirely via the BMS through one of the integrated BACnet on-board interfaces or the interface of one of the optional BACnet or LonWorks gateway boards the "Control Settings" must be adjusted as follows:

1. Close control unit and switch it on.
2. Select "Control Settings" submenu as shown below.



3. Set **control settings** as follows (see rightmost screen):

Signal Source: **BACnet/IP** or **BACnet/MSTP**
System Mode: **Humidifying** or **Cooling** (only by ME)
Control Mode: **Demand** (if you use a external demand control signal)
RH P (if a sensor signal and proportional controller is used)
RH PI (if a sensor signal and proportional-integral controller is used)

Note: see "Operation Manual" of the corresponding for details on control settings.

3.3.1.3 Monitoring of bus communication from software version 5.7.x.x:

The monitoring of the bus communication described below only takes place if the "Source" parameter in the "Control Settings" menu is not set to "Analog".

As soon as the signal is transmitted via the BACnet IP or BACnet MSTP bus system, communication via the bus system is also monitored.

The control signal must be periodically updated within the time set in "BMS Timeout".

If the control signal is not updated within the set time, warning W35 "BMS Timeout" will be triggered and the humidification will be stopped until a valid signal is returned.

This monitoring is intended to prevent the humidifier from humidifying with the last transmitted value in the event of a bus failure.

3.4 Communication tables

3.4.1 DL - BACnet on-board (Integrated Controller Software version 5.7.x.x)

Object Name	Description	Range	Object-Type	Object-ID	Read (R) Write (W)
Integrated Controller	Humidifier	—	DEV	1001	—
Hum. Status	Operating status	1 = Initializing 2 = Diagnostic 3 = Stopped 4 = Flushing 5 = Standby 6 = Flushed 7 = Humidifying 8 = Ready 9 = Refreshing 10 = Air Prs.Cleaning 11 = Filling 12 = Cond.Flush 13 = Switched Off 14 = Remote Off 15 = Regenerating	MI	500	R
Service Status	Maintenance and malfunctions status	1 = Service Info 2 = Warning 3 = Activation Code 4 = Out of Commissioning 5 = Refill Disinfection 6 = Service 7 = Fault	MI	549	R
Device Type	Device type	1 = Hum 2 = Hum + FC 3 = Hum + RO-C 4 = RO	MI	597	R
Fault Code	Error code ²⁾	0 = no Error	AI	10759	R
Operating Hours	Operating hours	0 - 1'200'000 h	AI	10699	R
Next Service	Next service	0 - 10000 h	AI	10700	R
Humidity Control	Actual humidity or demand	0 - 100 %	AI	10729	R
Max. Capacity	Max. capacity ¹⁾	2 - 1000 kg/h 4 - 2573 lb/hr	AI	10596	R
Capacity	Actual capacity ¹⁾	0 - 1000 kg/h 0 - 2573 lb/hr	AI	10702	R
Remain.Capacity	Remaining Ag-Ion Capacity	0 - 58.4 Ah	AI	10701	R
Target Ag-Ion Curr.	Target Ag-Ion Current	0 - 29.2 mA	AI	10703	R
PS4	Inlet pressure PS4 ¹⁾	0 - 12.0 bar 0 - 174.0 psi	AI	10732	R
PS5	Nozzle pressure PS5 ¹⁾	0 - 12.0 bar 0 - 174.0 psi	AI	10733	R
Condu Water Temp.	Water temperature ¹⁾	°C or °F	AI	10734	R
Conductivity	Conductivity	µS/cm	AI	10735	R
Pump Current	Pump current	0 - 5.0 A	AI	10727	R
Ag-Ion Current	Ag-Ion current	mA	AI	10632	R

¹⁾ According to the settings <Imperial> or <Metric> in the DL controller software.

²⁾ See Error code description in the malfunction list in the DL operation manual.

Object Name	Description	Range	Object-Type	Object-ID	Read (R) Write (W)
Setpoint	Humidity setpoint	0 - 95 %	AV	10602	R/W
Band Channel 1	Proportional band	6 - 65 %	AV	10604	R/W
ITime Channel 1	Integral time	1 - 60 min	AV	10606	R/W
Manual Capacity A	Manual capacity	20 - 100 %	AV	10610	R/W
RhorDemand	Actual humidity or demand via BACnet	0 - 100 % Relinquish Default = 0	AO	10611	R/W

Object Name	Description	Range	Object-Type	Object-ID	Read (R) Write (W)
Safety Loop	Safety loop	0 = Open 1 = Closed (ok)	BI	578	R
Y1	Y1 inlet valve	0 = Closed 1 = Open	BI	603	R
Y2	Y2 valve	0 1	BI	604	R
Y3	Y3 valve air cleaning	0 = Closed 1 = Open	BI	605	R
Y4	Y4 valve external pipe flush	0 = Closed 1 = Open	BI	606	R
Y5	Y5 valve spray circuit	0 = Closed 1 = Open	BI	607	R
Y6	Y6 valve spray circuit	0 = Closed 1 = Open	BI	608	R
Y7	Y7 valve spray circuit	0 = Closed 1 = Open	BI	609	R
Y8	Y8 valve spray circuit	0 = Closed 1 = Open	BI	610	R
Y9	Y9 valve spray circuit	0 = Closed 1 = Open	BI	611	R
Y10	Y10 valve drain (NO)	0 = Open 1 = Closed	BI	612	R
Y11	Y11 valve	0 1	BI	613	R
FC Enable	FC enable	0 = Off 1 = On	BI	636	R

3.4.2 ME - BACnet on-board (Integrated Controller software version 5.7.x.x)

Object Name	Description	Range	Object-Type	Object-ID	Read (R) Write (W)
Integrated Controller	Humidifier	—	DEV	1001	—
Operation Status	Operating status	1 = Initializing 2 = Diagnostic 3 = Stopped 4 = Humidifying 5 = Cooling 6 = Holding 7 = Draining 8 = Refreshing 9 = Filling 10= Standby 11= Diluting 12= Drain Assisting 13= Bleeding 14= Ramping Up 15= Switched Off 16= Remote Off 17= Purging 18= Drain Check	MI	500	R
Service Status	Maintenance and malfunctions status	1 = Service Info 2 = Warning 3 = Service 4 = Refill Liquid 5 = Replace PureFlow Ag+ 6 = Replace UV Bulb 7 = Matrix Wash Over 8 = Out of Comissioning 9 = Activation Code 10= Fault	MI	549	R
Fault Code	Error code ²⁾	0 = no Error	AI	10650	R
Operating Hours	Operating hours	0 - 1'200'000 h	AI	10626	R
Next Service	Next service	0 - 10000 h	AI	10627	R
Next UV Bulb exchange	Next UV bulb exchange	0 - 450 d	AI	10628	R
Next PureFlo Ag+ exchange	Next PureFlo Ag+ exchange	0 - 350 d	AI	10629	R
Humidity Control	Actual humidity or demand	0 - 100 %	AI	10526	R
Temperature Control	Actual air temperature ¹⁾	°C or °F	AI	10527	R
UV Current	UV current	0 - 4.0 A	AI	10532	R
Capacity 1	Water capacity stage 1 ¹⁾	5.0 - 200.0 kg/h 11.0 - 440.9 lb/h	AI	10588	R
Capacity 2	Water capacity stage 2 ¹⁾	5.0 - 200.0 kg/h 11.0 - 440.9 lb/h	AI	10589	R
Capacity 3	Water capacity stage 3 ¹⁾	5.0 - 200.0 kg/h 11.0 - 440.9 lb/h	AI	10590	R
Capacity 4	Water capacity stage 4 ¹⁾	5.0 - 200.0 kg/h 11.0 - 440.9 lb/h	AI	10591	R
Capacity 5	Water capacity stage 5 ¹⁾	5.0 - 200.0 kg/h 11.0 - 440.9 lb/h	AI	10952	R
Capacity 6	Water capacity stage 6 ¹⁾	5.0 - 200.0 kg/h 11.0 - 440.9 lb/h	AI	10622	R
Capacity 7	Water capacity stage 7 ¹⁾	5.0 - 200.0 kg/h 11.0 - 440.9 lb/h	AI	10623	R
Speed Pump 1	Demand pump 1	0 - 100 %	AI	10631	R
Speed Pump 2	Demand pump 2	0 - 100 %	AI	10632	R
Speed Pump 3	Demand pump 3	0 - 100 %	AI	10633	R

Object Name	Description	Range	Object-Type	Object-ID	Read (R) Write (W)
Speed Pump 4	Demand pump 4	0 - 100 %	AI	10634	R
Speed Pump 5	Demand pump 5	0 - 100 %	AI	10635	R
Speed Pump 6	Demand pump 6	0 - 100 %	AI	10636	R
Speed Pump 7	Demand pump 7	0 - 100 %	AI	10637	R
Conductivity	Conductivity	µS	AI	10530	R
Water Temperature	Actual water temperature ¹⁾	°C or °F	AI	10529	R
Incoming Air Temperature	Actual air temperature ¹⁾	°C or °F	AI	10528	R
Actual Stage	Number of running stages	0 - 7 stages	AI	10624	R
Level	Water level in tub	0 - 8	AI	10595	R

¹⁾ According to the settings <Imperial> or <Metric> in the ME controller software.

²⁾ See Error code description in the malfunction list in the ME operation manual.

Object Name	Description	Range	Object-Type	Object-ID	Read (R) Write (W)
Setpoint Channel 1	Humidity setpoint	0 - 95 %	AV	10602	R/W
Band Channel 1	Proportional band humidity control	6 - 65 %	AV	10604	R/W
ITime Channel 1	Integral time humidity control	1 - 60 min	AV	10606	R/W
Setpoint Channel 2	Temperature setpoint ¹⁾	5 - 40 °C 41 - 104 °F	AV	10603	R/W
Band Channel 2	Proportional band temperature control ¹⁾	1 - 50 °C 34 - 122 °F	AV	10605	R/W
ITime Channel 2	Integral time temperatur control	1 - 60 min	AV	10607	R/W
Manual Mode	Matrix wash over / Tank draining	Read: 0 = Off 1 = Initialisation 2 = Process active 3 = Process completed Write: 0 = Stop active process 1 = Start matrix wash over 2 = Start tank draining	AV	10675	R/W
RHorDemand	Actual humidity or demand via BACnet	0 - 100% Relinquish Default = 0	AO	10611	R/W
Temperature	Actual temperature via BACnet ¹⁾	-25 - 100 °C -13 - 212 °F Relinquish Default = 0	AO	10612	R/W

¹⁾ According to the settings <Imperial> or <Metric> in the ME controller software.

Object Name	Description	Range	Object-Type	Object-ID	Read (R) Write (W)
Safety Loop	Safety loop	0 = Open 1 = Closed (ok)	BI	532	R
Dosing Pump Level Float	Dosing pump level	0 = Empty 1 = Ok	BI	534	R
Standing Water	Leakage sensor	0 = Fault 1 = Ok	BI	535	R
Drain Valve	Drain valve	0 = Open 1 = Closed	BI	537	R
Inlet Valve	Inlet valve	0 = Closed 1 = Open	BI	536	R
Drain Pump	Drain pump	0 = Off 1 = On	BI	551	R
Pump 1 Error	Fault pump 1	0 = Fault 1 = Ok	BI	572	R
Pump 2 Error	Fault pump 2	0 = Fault 1 = Ok	BI	573	R
Pump 3 Error	Fault pump 3	0 = Fault 1 = Ok	BI	574	R
Pump 4 Error	Fault pump 4	0 = Fault 1 = Ok	BI	575	R
Pump 5 Error	Fault pump 5	0 = Fault 1 = Ok	BI	576	R
Pump 6 Error	Fault pump 6	0 = Fault 1 = Ok	BI	577	R
Pump 7 Error	Fault pump 7	0 = Fault 1 = Ok	BI	578	R
Water Inlet	Fault water inlet	0 = Fault 1 = Ok	BI	579	R
Water Temp	Fault water temperature	0 = Fault 1 = Ok	BI	580	R
Water Outlet	Fault water outlet	0 = Fault 1 = Ok	BI	581	R
Level Sensor	Fault level sensor	0 = Fault 1 = Ok	BI	582	R
Water Condu	Fault water conductivity	0 = Fault 1 = Ok	BI	583	R
System Reset	Remote reset	0 = Off 1 = On	BV	586	R/W

3.4.3 RS - BACnet on-board (Integrated Controller software version 5.7.x.x)

Object Name	Description	Range	Object-Type	Object-ID	Read (R) Write (W)
Integrated Controller	Humidifier	—	DEV	1001	—
Status A	Operating status unit A	1 = Initializing 2 = Diagnostic 3 = Stopped 4 = Break 5 = Level test 6 = Standby 7 = Humidifying 8 = Filling 9 = Idle 10 = Draining 11 = Remote off 12 = Keep Warm	MI	500	R
Status B	Operating status unit B	1 = Initializing 2 = Diagnostic 3 = Stopped 4 = Break 5 = Level test 6 = Standby 7 = Humidifying 8 = Filling 9 = Idle 10 = Draining 11 = Remote off 12 = Keep Warm	MI	654	R
Service Status A	Maintenance and malfunctions status unit A	1 = Service Info 2 = Warning 3 = RO Service 4 = Extended Maint. 5 = Small Maint. 6 = Activation Code 7 = Fault	MI	549	R
Service Status B	Maintenance and malfunctions status unit B	1 = Service Info 2 = Warning 3 = RO Service 4 = Extended Maint. 5 = Small Maint. 6 = Activation Code 7 = Fault	MI	655	R
Mode	Device type	1 = RS 2 = RS+ RO 3 = RO	MI	717	R
Nominal Voltage	Nominal voltage	1 = 200 V 2 = 208 V 3 = 230 V 4 = 240 V 5 = 400 V 6 = 415 V 7 = 440 V 8 = 460 V 9 = 480 V 10 = 500 V 11 = 550 V 12 = 600 V 13 = 380 V	MI	699	R
Level A	Water level unit A	0 = no level 1 = low 2 = low-mid 3 = mid 4 = mid-high 5 = high	AI	10820	R

Object Name	Description	Range	Object-Type	Object-ID	Read (R) Write (W)
Level B	Water level unit B	0 = no level 1 = low 2 = low-mid 3 = mid 4 = mid-high 5 = high	AI	10821	R
Fault Code	Error code ²⁾	0 = No Error	AI	10823	R
Operating Hours	Operating hours	0 - 1'200'000 h	AI	10699	R
Next Service A	Next service unit A	0 - 6000 h	AI	10758	R
Next Service B	Next service unit B		AI	10759	R
System Demand	System demand	0 - 100 %	AI	10057	R
Channel 1	Input signal channel 1 unit A	0 - 100 %	AI	10001	R
Channel 2	Limiter signal channel 2 unit A	0 - 100 %	AI	10002	R
Max Capacity	Max. capacity ¹⁾	5 - 160 kg/h 10 - 360 lb/hr	AI	10596	R
Capacity A	Max. capacity unit A ¹⁾	5 - 40 kg/h 10 - 90 lb/hr	AI	10754	R
Capacity B	Max. capacity unit B ¹⁾	5 - 40 kg/h 10 - 90 lb/hr	AI	10755	R
Capacity	Actual capacity ¹⁾	5 - 160 kg/h 10 - 360 lb/hr	AI	10702	R
Cylinder A	Actual capacity unit A ¹⁾	0 - 40 kg/h 0 - 90 lb/hr	AI	10734	R
Cylinder B	Actual capacity unit B ¹⁾	0 - 40 kg/h 0 - 90 lb/hr	AI	10735	R

¹⁾ According to the settings <Imperial> or <Metric> in the RS controller software.

²⁾ See Error code description in the malfunction list in the RS operation manual.

Object Name	Description	Range	Object-Type	Object-ID	Read (R) Write (W)
Setpoint Channel 1	Setpoint channel 1 unit A	0 - 95 %	AV	10010	R/W
Setpoint Channel 2	Setpoint channel 2 limiter unit A	10 - 95 %	AV	10013	R/W
Band Channel 1	P-Band unit A (Proportionalband)	6 - 65 %	AV	10011	R/W
Band Channel 2	P-Band limiter unit A (Proportionalband)	6 - 65 %	AV	10014	R/W
ITime Channel 1	Integral time channel 1 unit A	1 - 60 min	AV	10012	R/W
Damp Channel 2	Damp time channel 2 unit A	0 - 60 s	AV	10015	R/W
Manual Capacity A	Manual capacity unit A	20 - 100 %	AV	10008	R/W
Digital RH/Demand A1	Actual humidity or demand via BACnet unit A	0 - 100 % Relinquish Default = 0	AO	10044	R/W
Digital RH/Demand A2	Actual humidity or limiter via BACnet unit A	0 - 100 % Relinquish Default = 0	AO	10045	R/W

Object Name	Description	Range	Object-Type	Object-ID	Read (R) Write (W)
Blower Pack A	Blower ready unit A	0 = Off 1 = On	BI	653	R
Blower Pack B	Blower ready unit B	0 = Off 1 = On	BI	689	R
Safety Loop A	External safety loop unit A	0 = Open 1 = Closed (ok)	BI	578	R
Safety Loop B	External safety loop unit B	0 = Open 1 = Closed (ok)	BI	662	R
Overheat Switch A	Internal safety loop unit A	0 = Open 1 = Closed (ok)	BI	648	R
Overheat Switch B	Internal safety loop unit B	0 = Open 1 = Closed (ok)	BI	685	R
Heating Voltage A	Heating voltage unit A	0 = Off 1 = On	BI	650	R
Heating Voltage B	Heating voltage unit B	0 = Off 1 = On	BI	687	R
Temperature Switch A	Internal safety loop unit A (security level)	0 = Open 1 = Closed (ok)	BI	649	R
Temperature Switch B	Internal safety loop unit B (security level)	0 = Open 1 = Closed (ok)	BI	686	R
Leakage Sensor A	Leakage sensor unit A	0 = Off (Leak) 1 = On	BI	647	R
Leakage Sensor B	Leakage sensor unit B	0 = Off (Leak) 1 = On	BI	684	R
Main Contactor A	Contactor unit A	0 = Off 1 = On	BI	733	R
Main Contactor B	Contactor unit B	0 = Off 1 = On	BI	734	R
Relay Pump AC A	Pump unit A	0 = Off 1 = On	BI	735	R

Object Name	Description	Range	Object-Type	Object-ID	Read (R) Write (W)
Relay Pump AC B	Pump unit B	0 = Off 1 = On	BI	736	R
Inlet 1 A	Inlet valve 1 unit A	0 = Closed 1 = Open	BI	760	R
Inlet 1 B	Inlet valve 1 unit B	0 = Closed 1 = Open	BI	761	R
Inlet 2 A	Inlet valve 2 unit A	0 = Closed 1 = Open	BI	762	R
Inlet 2 B	Inlet valve 2 unit B	0 = Closed 1 = Open	BI	763	R
Drain 1 A	Drain cool valve unit A	0 = Closed 1 = Open	BI	764	R
Drain 1 B	Drain cool valve unit B	0 = Closed 1 = Open	BI	765	R
Drain 2 A	Complete drain valve unit A	0 = Closed 1 = Open	BI	766	R
Drain 2 B	Complete drain valve unit B	0 = Closed 1 = Open	BI	767	R
Fan Activate A	External fan unit A	0 = Off 1 = On	BI	777	R
Fan Activate B	External fan unit B	0 = Off 1 = On	BI	778	R
Flush A	Hygiene flush unit A	0 = Closed 1 = Open	BI	781	R
Flush B	Hygiene flush unit B	0 = Closed 1 = Open	BI	782	R

3.5 Operating trouble list

Problem	Solutions
Cannot see/change set object/parameter from BMS	<p>Check "Control Mode" setting in the "Control Settings" submenu.</p> <ul style="list-style-type: none"> – Demand type controls use internal algorithms to generate a signal telling the Condair Integrated Controller to operate at a certain output percentage. These types of controls do not report the detected humidity or temperature level or set point to the Condair Integrated Controller. As a result the set point and humidity/temperature levels cannot be monitored through the Condair Integrated Controller when using demand controls. – Sensor ("transducer") type controls report a sensed humidity/temperature value to the Condair Integrated Controller. The set point is configured at the control unit and the Condair Integrated Controller uses internal algorithms to determine the output percentage. Since the Condair Integrated Controller knows both the set point and humidity/temperature level, these values may be monitored through the Condair Integrated Controller. <p>Note: "Control Mode" must be set to "rH P" or "rH PI".</p>
Cannot read data	<ul style="list-style-type: none"> – Check correct using of data type on the BMS.
Only some objects/parameters report data	<ul style="list-style-type: none"> – Check the baud rate being used on the BMS network. Use of faster baud rates may assist. – Check the polling rate being used. High polling rates can cause data collision. A recommended polling rate is once per minute.
Condair Integrated Controller will not respond to set point/sensor values/demand values written over BACnet.	<ul style="list-style-type: none"> – Check that Condair Integrated Controller is configured to be controlled via automation system (see chapter 3.3.1). Note: If "Source" in the controller settings is set to "Analog" the Condair Integrated Controller will look for a control signal connected to the driver board only.
The device will not respond to control signal connected to the driver board.	<ul style="list-style-type: none"> – Check that "Source" in the controller settings is configured for "Analog" control. Note: If the "Signal Source" is set to "Modbus", the Condair Integrated Controller will look for a control value sent by the BMS.
The BACnet node ID, BACnet IP port or BACnet MSTP MAC settings are not accepted. Original values remain active.	<ul style="list-style-type: none"> – Check if the input is within the valid value range. If this is not the case, the entered value is ignored.

Problem	Solutions
Intermittent Communications.	<ul style="list-style-type: none"> – Check whether the wire type and run length meet the requirements of the corresponding network. – Look for wire runs in close proximity to equipment generating significant electrical noise (such as VFD's, medical equipment, X-ray machinery, servers, etc). – Check that wire shield is terminated at one end only. – Confirm correct polarity of conductors at each device. – Check BACnet/LonWorks addresses for conflicts with any device. <p>Note: Each device on the network must have a unique address.</p>
No communication can be established	<ul style="list-style-type: none"> – Check that latest software version of the device is installed. – With BACnet IP: Check the IP address, subnet mask and default gateway. These parameters must be in the same range as the client (client = BACnet device, for example a building controller or workstation requesting data from the humidifier) Check if other network participants or firewalls are blocking BACnet messages. – With BACnet MS/TP Master: Check the MAC address. This should be in the range 0-127. The value in the Device Object property "Max Master" must be equal to or higher than the MAC address.. – With BACnet MS/TP Slave: MS/TP slave devices can not be detected automatically via the "Who-is" BACnet service and therefore have to be manually added to the network.
Invalid data	<ul style="list-style-type: none"> – Check BACnet addresses for conflicts with any device. <p>Note: Each device on the network must have a unique address.</p>
Error code "0" is shown though a fault is present on the Integrated Controller.	<ul style="list-style-type: none"> – Check software version of the Integrated Controller. Error code indication is not supported with software version 1.x.x.x.
Wrong values (e.g. temperature, pressure, mass flow) are shown via BMS.	<ul style="list-style-type: none"> – Check software version of the Integrated Controller. – Check the "Units" setting in the "General" menu.

Problem	Solutions
More variables or additional information is required from the Condair Integrated Controller.	Contact Condair Technical Services for additional support.
The "Units" property is not defined for all BACnet objects, although the BACnet standard lists these units.	<ul style="list-style-type: none"> <li data-bbox="730 331 1477 465">– BACnet objects that have units which differ depending on the setting "Metric" or "Imperial" are not fixed implemented. These include units such as temperature (°C or °F), pressure (bar or psi), mass flow (kg/h or lbs/hr).

4 Network integration via the optional LonWorks and BACnet Gateway boards

4.1 Notes for the planning engineer

4.1.1 Overview

The optional LonWorks or BACnet gateway boards allow the integration of the Condair Integrated Controller into a **BACnet IP**, **BACnet MS/TP** or a **LonWorks** network. The optional LonWorks or BACnet gateway boards feature a serial-interface Gateway which converts the information from the host RTU Modbus protocol to a specified secondary protocol.

Important: Please note that the gateway board is configured for the latest software version of the Integrated Controller. To guarantee correct data communication it is therefore mandatory to update the software of the Integrated Controller to the latest version before installing the gateway board. Please contact your Condair distributor regarding a software update of the Integrated Controller.

The following protocol options are available and must be specified when ordering:

Part Number	Protocols	Part Description
2583810	BACnet IP	BMS Set Master BACnet IP ME
2583813	BACnet MS/TP	BMS Set Master BACnet MS/TP ME
2583808	LonWorks	BMS Set Master LonWorks ME
2583809	BACnet IP	BMS Set Master BACnet IP RS
2583812	BACnet MS/TP	BMS Set Master BACnet MS/TP RS
2583807	LonWorks	BMS Set Master LonWorks RS
2582291	BACnet IP	BMS Set Master BACnet IP DL
2583811	BACnet MS/TP	BMS Set Master BACnet MS/TP DL
2582290	LonWorks	BMS Set Master LonWorks DL
2586239	BACnet IP	BMS Set Master BACnet IP EL
2586240	BACnet MS/TP	BMS Set Master BACnet MS/TP EL
2587508	LonWorks	BMS Set Master LonWorks EL

Please refer to the BACnet object or Lonworks SNVT tables in [chapter 4.4](#) for detailed information regarding the available read out and settings functions.

4.1.2 Principle Network diagrams

4.1.2.1 Principle BACnet network

The principle diagram below shows the connection of the Condair Integrated Controller to an Ethernet network.

Principle BACnet IP network



Abb. 3: Principle BACnet IP network

Principle BACnet MS/TP network

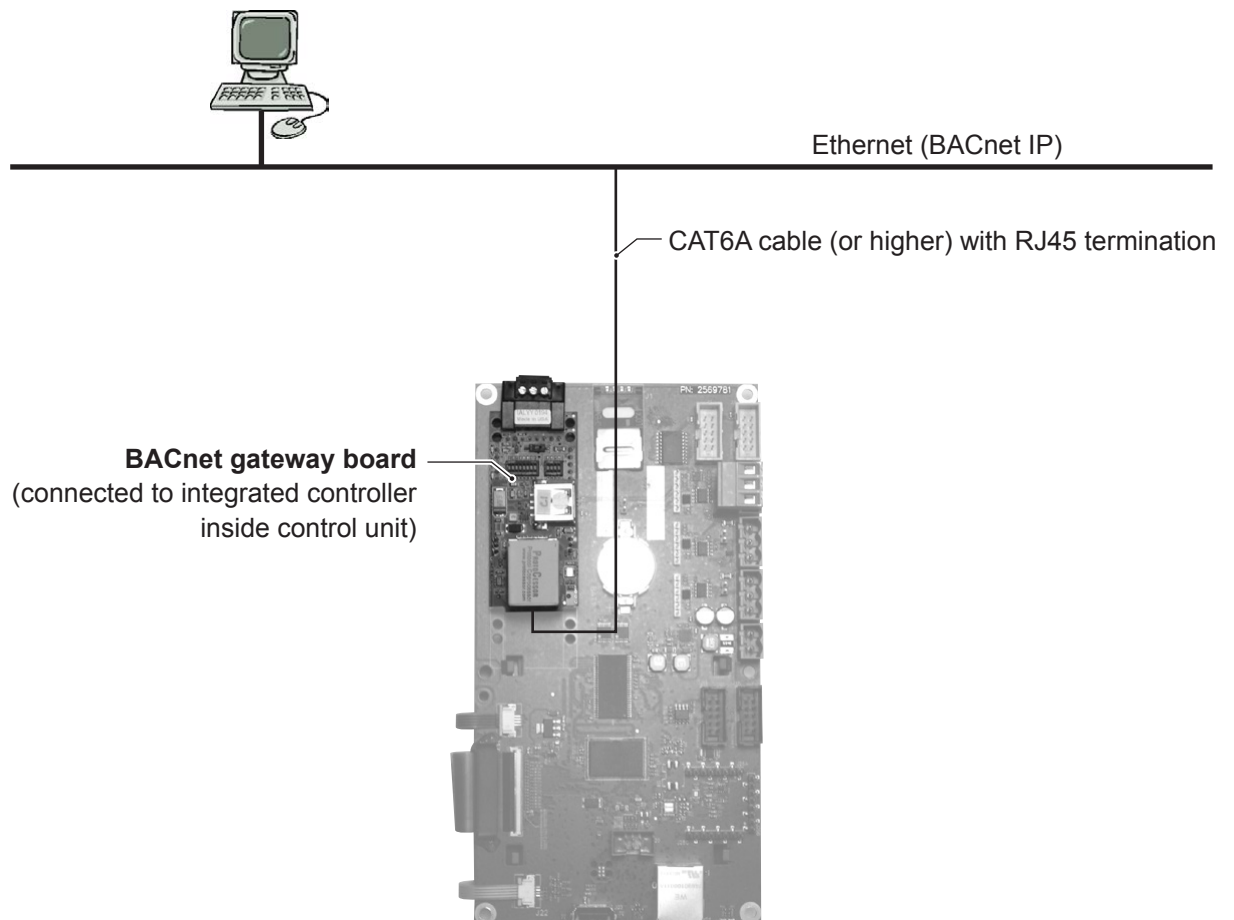

Abb. 4: Principle BACnet MS/TP network

4.1.2.2 Principle LonWorks network

This principle diagram below shows the connection of the Condair Integrated Controller to a LonWorks network via a shielded twisted-pair cable.

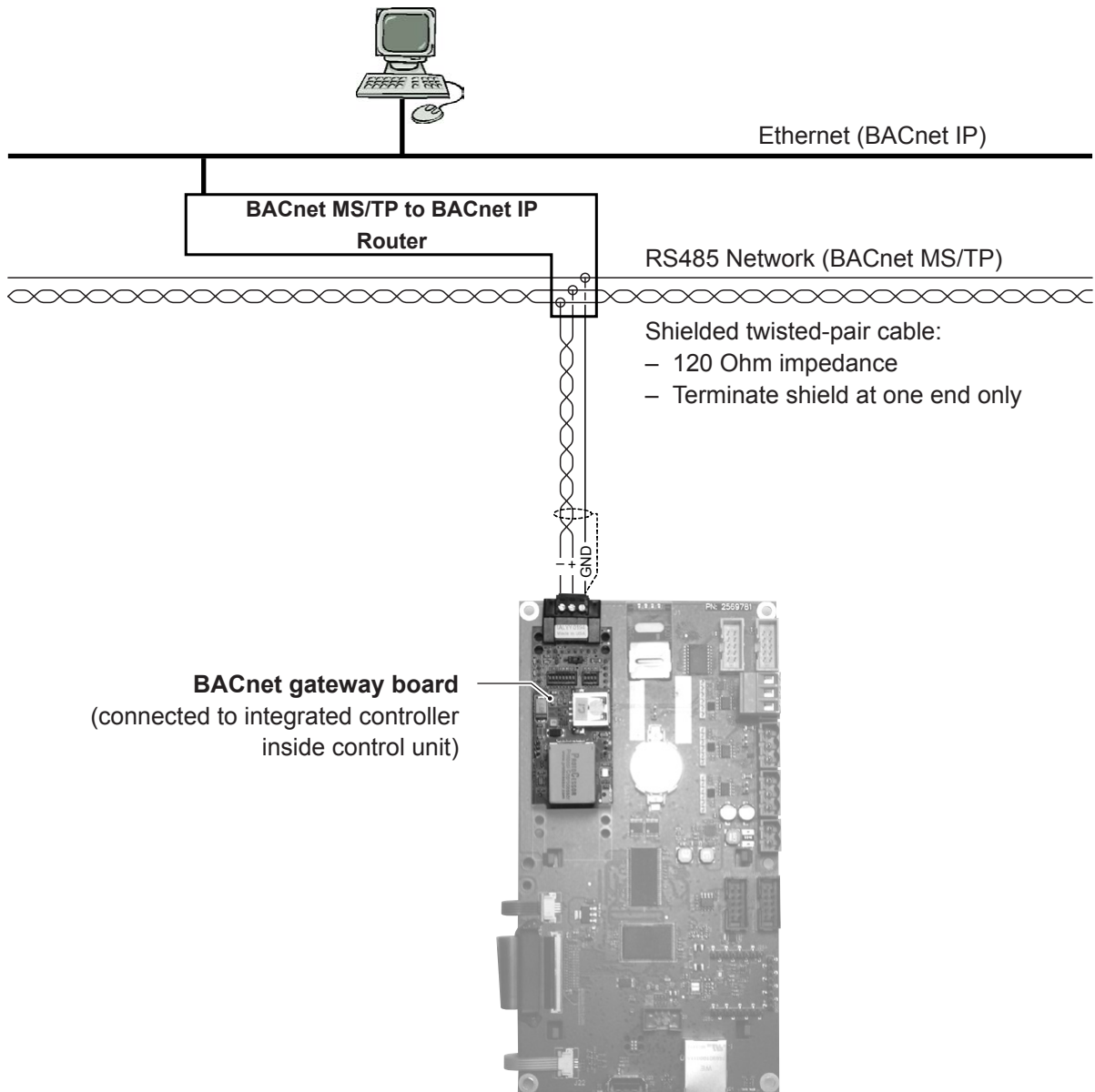

Abb. 5: Principle LonWorks network

4.2 Installation work

4.2.1 Installing the BACnet/LonWorks gateway board on the Integrated Controller

1. Isolate power supply to the controller unit.
2. Remove the front cover of the control unit.

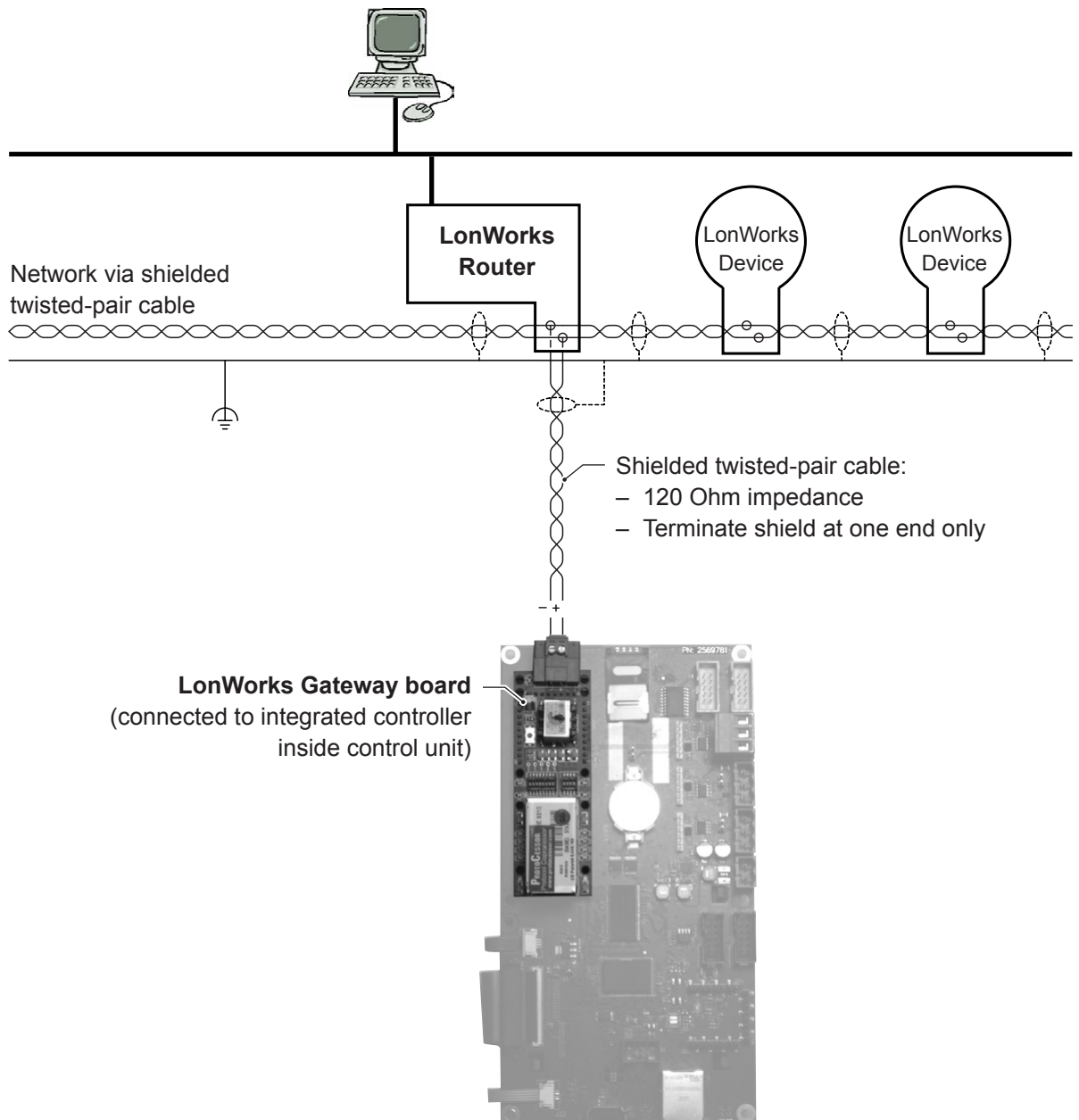
CAUTION!

Electronic components are very sensitive to electrostatic discharge. Before proceeding with the next step, appropriate measures (ESD-protection) must be taken to prevent damage to electronic components. A wrist strap should be worn to connect the maintenance specialist with a common ground point. For more information, refer to ANSI/ESD-S20.20.

3. Open the control unit inner door.
4. Fix BACnet or LonWorks gateway board to the TTL interface on the Condair Integrated Controller. **Important:** Ensure pin alignment when fixing.
5. Remove Jumper "J7".



Abb. 6: Installing the BACnet/LonWorks gateway board on the integrated controller (ME control module shown).

4.2.2 Wiring

1. Lead the network cable through the rectangular cable lead-through into the control unit. Inside the control unit run the cable to the BACnet or LonWorks gateway board, respectively.
2. Connect network cable according to the following wiring diagrams.

BACnet

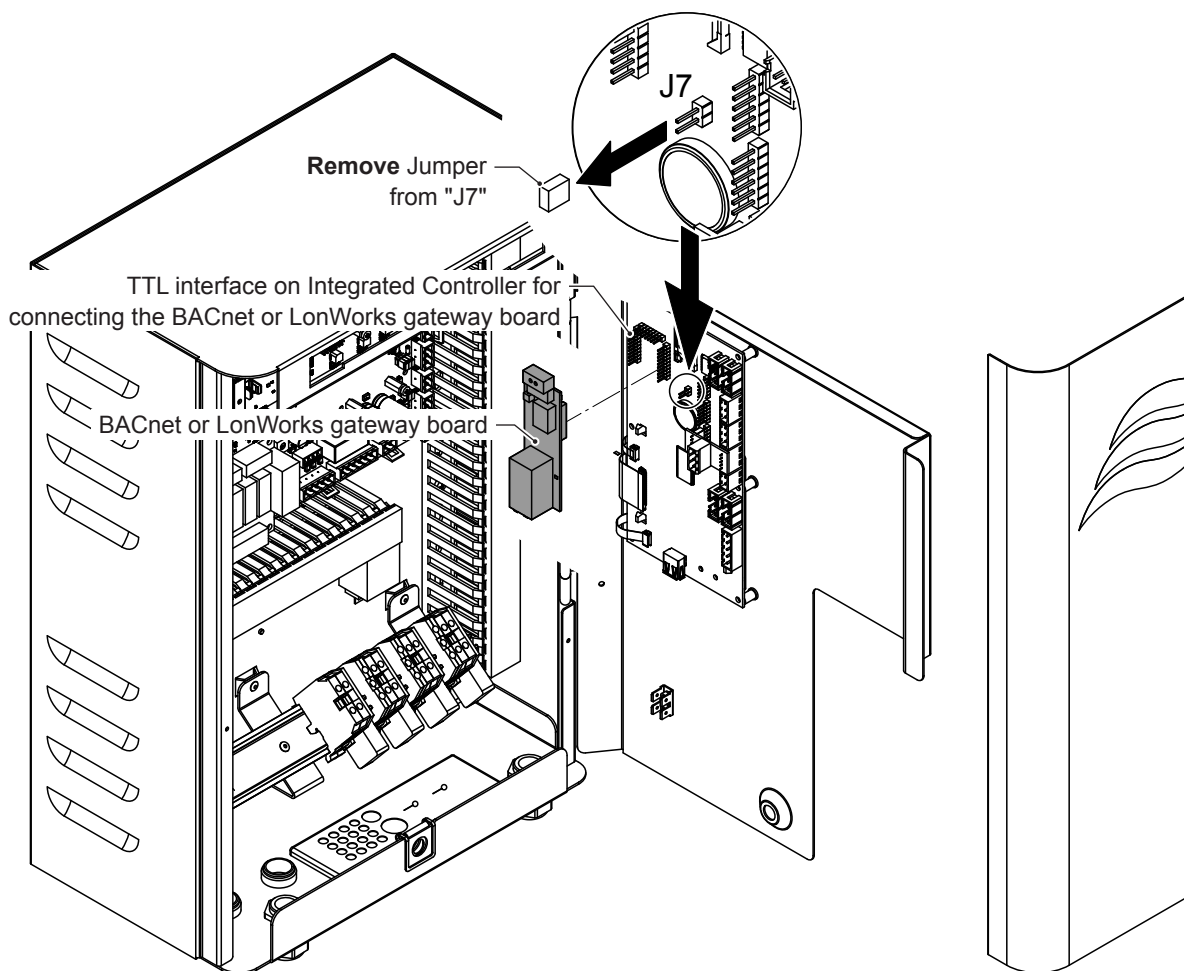

Abb. 7: BACnet IP network connection

To network via shielded twisted-pair cable:

- 120 Ohm impedance
- Terminate shield at one end only

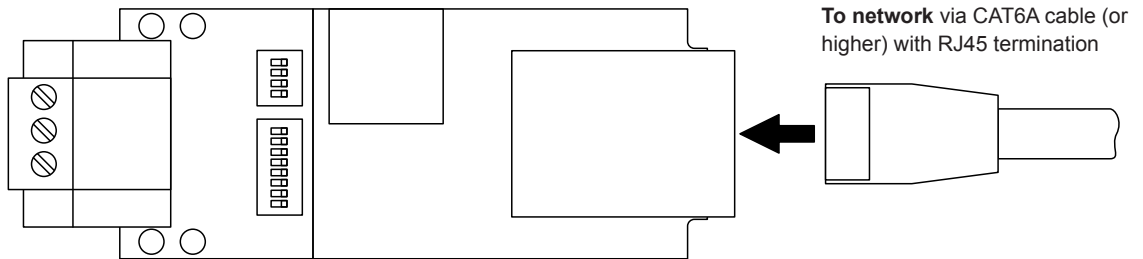

Abb. 8: BACnet MS/TP network connection

LonWorks

To network via shielded twisted-pair cable:

- 120 Ohm impedance
- Terminate shield at one end only

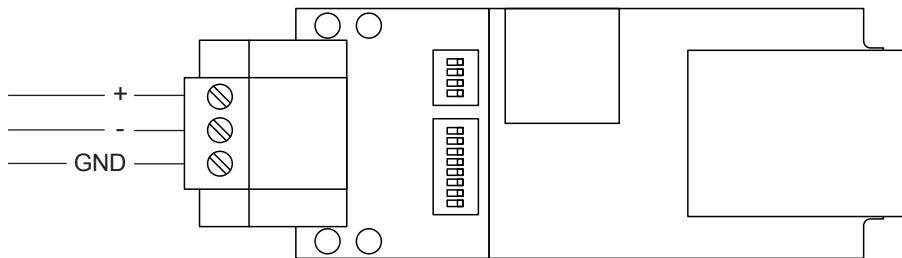

Abb. 9: LonWorks network connection

4.3 Configuration

After wiring connections have been completed, the Condair Integrated Controller needs to be setup to operate and communicate through its optional BACnet or LonWorks gateway board. This setup includes the settings in the "Control Settings" and the "Communication" submenu of the Condair Integrated Controller unit and the **Gateway configuration**.

4.3.1 Configuring the Condair Integrated Controller (software version 5.7.x.x)

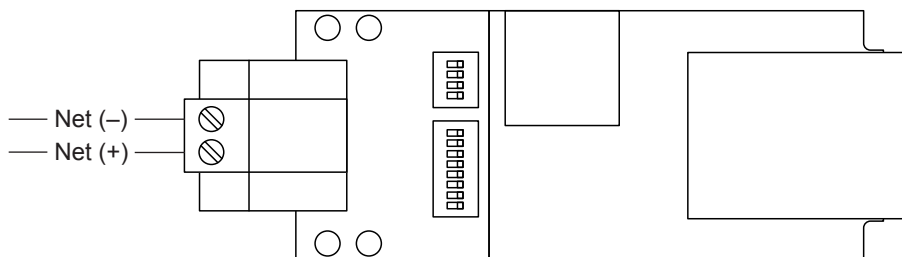
4.3.1.1 Setup control settings

By default the Condair Integrated Controller is configured to operate on a hardwired analog control signal from an external humidity controller or a humidity sensor (if internal P or PI controller is used) connected to the driver board inside the control unit.

Note: If you want the Condair Integrated Controller to be controlled via a hardwired analog control signal set "Signal Source" to "Analog" and set the other control settings as required (see "Operation Manual" of the corresponding device for details).

If you want to control the Condair Integrated Controller entirely via the BMS through the optional BACnet or LonWorks interface the "Control Settings" must be adjusted as follows:

1. Close control unit and switch it on.
2. Select "Control Settings" submenu as shown below.



3. Set **control settings** as follows (see rightmost screen):

Signal Source: **Modbus**
System Mode: **Humidifying** or **Cooling** (only by ME)
Control Mode: **Demand** (if you use a external demand control signal)
RH P (if you use a sensor signal and proportional controller)
RH PI (use a sensor value and proportional-integral controller)

Note: see Humidifier Operation Manual for details on control settings.

4.3.1.2 Monitoring of bus communication from software version 5.7.x.x:

The monitoring of the bus communication described below only takes place if the "Source" parameter in the "Control Settings" menu is not set to "Analog".

As soon as the signal is transmitted via the BACnet IP or BACnet MSTP bus system, communication via the bus system is also monitored.

The control signal must be periodically updated within the time set in "BMS Timeout".

If the control signal is not updated within the set time, warning W35 "BMS Timeout" will be triggered and the humidification will be stopped until a valid signal is returned.

This monitoring is intended to prevent the humidifier from humidifying with the last transmitted value in the event of a bus failure.

Note: The gateway transfers the control signal to the humidifier only if the value changes!

4.3.1.3 BMS Timeout and Modbus settings

To allow the Condair Integrated Controller to be controlled via the BMS through the optional BACnet or LonWorks gateway board the Condair Integrated Controller must be configured as follows:

1. Switch on control unit (if not already switched on).
2. Select "Communication" submenu as shown below.

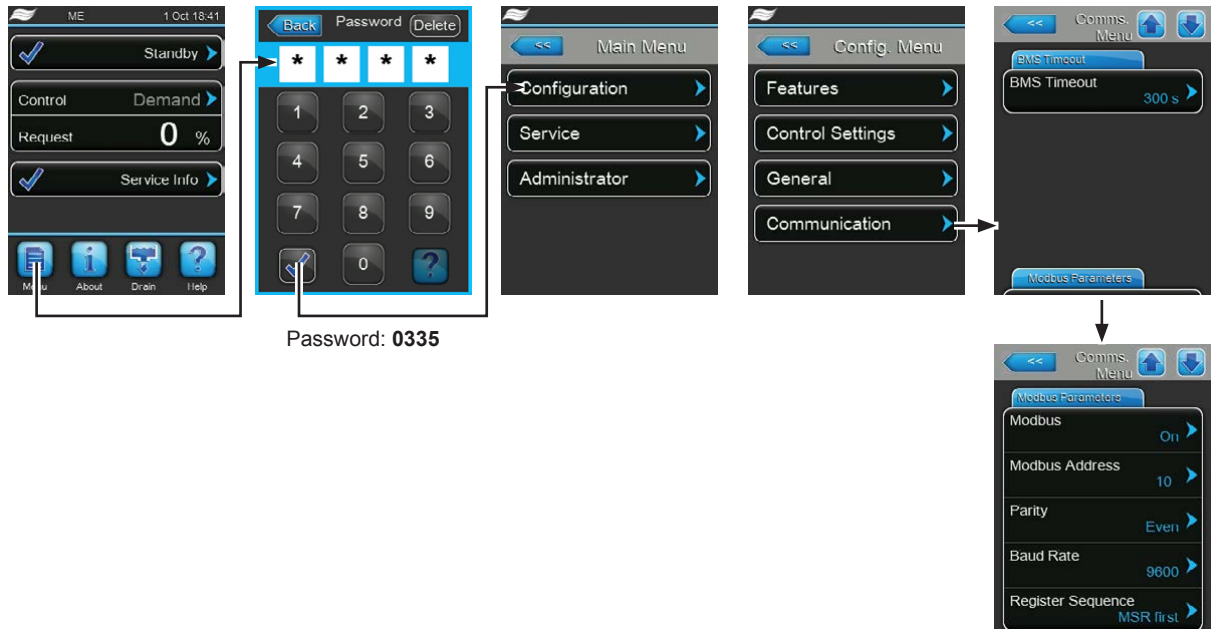

3. Select "**BMS Timeout**" tab and set **BMS Timeout** to the desired values:

Factory setting: **300 s**
Setting range: **1 - 300 s**

4. Select "**Modbus Parameter**" tab and set **Modbus settings** as follows (see rightmost screen):

Modbus: **On**
Modbus Address: **10**
Parity: **Even**
Baud Rate: **9600**
Register Sequence: **MSR first**

Important! Please note that the Gateway board is communicating with the Integrated Controller of the device via the Modbus RTU protocol. When using a gateway board the "**BACnet**" function in the "**Configuration > Communication**" submenu must be deactivated!

4.3.2 Gateway configuration

The **protocol configuration is made at the factory**, prior to final testing. The following values are set ex factory (adjustable values see [chapter 4.3.2.2](#) and [chapter 4.3.2.3](#)):

BACnet

Protocol	Baud rate	BACnet MS/TP MAC Address	Node ID	Parity
BACnet IP	10 / 100 BaseT	---	DL: 300 RS: 710 ME: 410 EL: 220	---
BACnet MS/TP Master	9600 Baud	127	1001	None

LonWorks

Protocol	Baud rate	Lonmark Objects		
LonWorks	78125 bps	#0 Node	#520 Analog Input *	#521 Analog Output

* The Condair RS consists of two analog input objects (Unit A and unit B). The second analog input object holds only the SNVT's of unit B.

4.3.2.1 Requirements for gateway configuration

Hardware Requirements

A PC with web browser that connects over Ethernet on port 80 and a Ethernet cable to establish the connection between Computer/Laptop and BACnet or LonWorks gateway board.

PC Software Requirements

One of the following web browsers must be used:

- Mozilla Firefox 13.0 and up
- Microsoft Internet Explorer 8 and up
- Google Chrome 19.0 and up
- Opera 11 and up

Please note that the computer and network firewalls must be opened for Port 80 to allow FS-GUI to function.

4.3.2.2 Configure the IP settings

For BACnet and LonWorks application, an IP address and the subnet mask must be assigned to the gateway of the BACnet/LonWorks gateway board in order to access it. The IP address and subnet mask may be assigned at the factory or can be modified at any time via the integrated FS-GUI (Graphic User Interface) of the gateway board.

Ex factory the gateway board is configured to the following default settings:

IP address	10.232.72.172
Subnet mask	255.255.0.0
Default gateway	10.232.72.1

To configure a new IP address, subnet mask and default gateway via the integrated FS-GUI of the gateway proceed as follows:

1. Connect the gateway board **to a PC using an Ethernet cross-over cable or directly to the network using a straight cable.**
2. Make sure your PC is in the same IP network as the Gateway board (default IP settings see table above); otherwise assign a static IP address (e.g. 10.232.72.100) to your PC.
3. Switch on Condair Integrated Controller unit in order to power up the Gateway board.
4. Open your internet browser and enter the IP address of the gateway (by default ex factory 10.232.72.172), then confirm the entry with the Enter key.

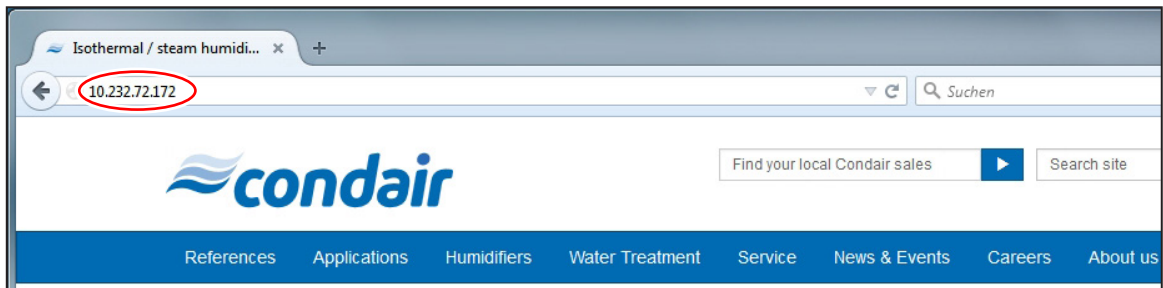

5. The FS-GUI (from Sierra Monitor or FieldServer Technologies) will be started.

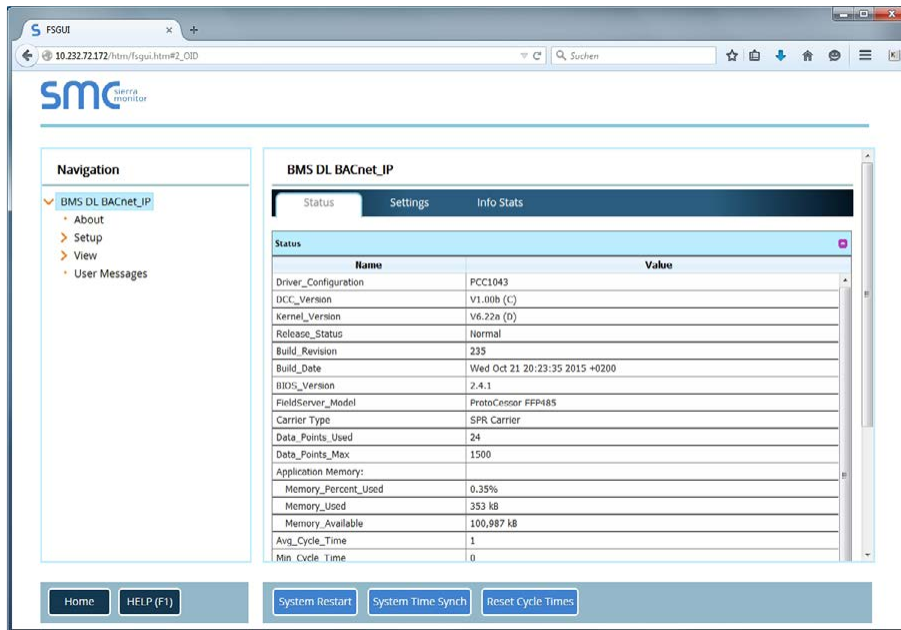

6. Select the menu point "**Setup > Network Settings**" in the "**Navigation Tree**". Enter the appropriate **IP-Address** and **subnet mask**. To activate the new settings, click first on the button **<Update IP settings>** and then on the button **<System Restart>**. After restart the gateway is configured to the new IP address and subnet mask.

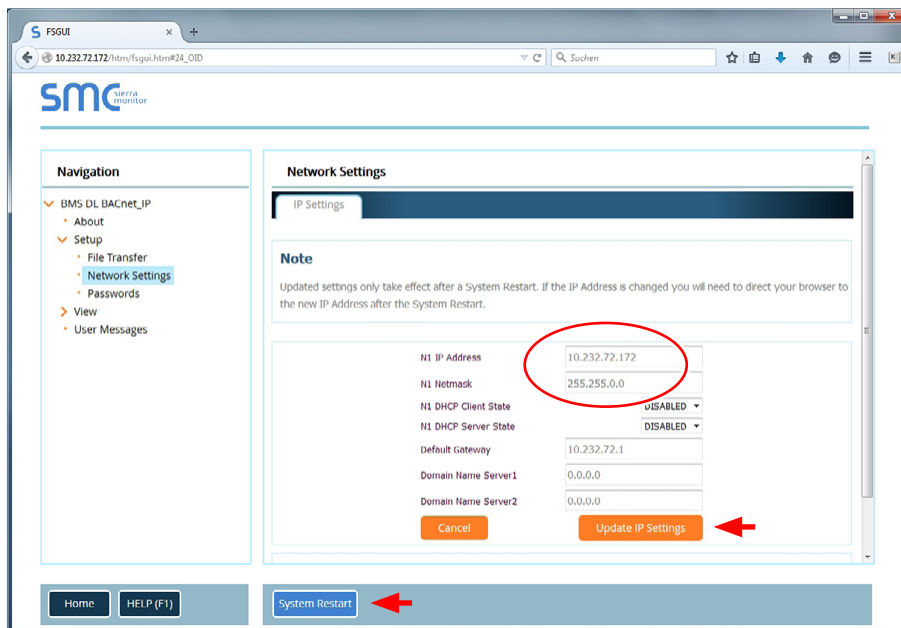

7. In order to access the gateway board, the IP address of your laptop must be set to the same network as the gateway board.

4.3.2.3 Modifying the BACnet gateway configuration

1. Enter the (new) IP address of the gateway in your internet browser and confirm the entry with the Enter key. The FS-GUI will be started.
2. Select the menu point "**Setup > File Transfer**" in the "**Navigation Tree**". Then, click in the "**Retrieve**" section on the link "**config.csv**" and save the configuration file to the desired location on your laptop.

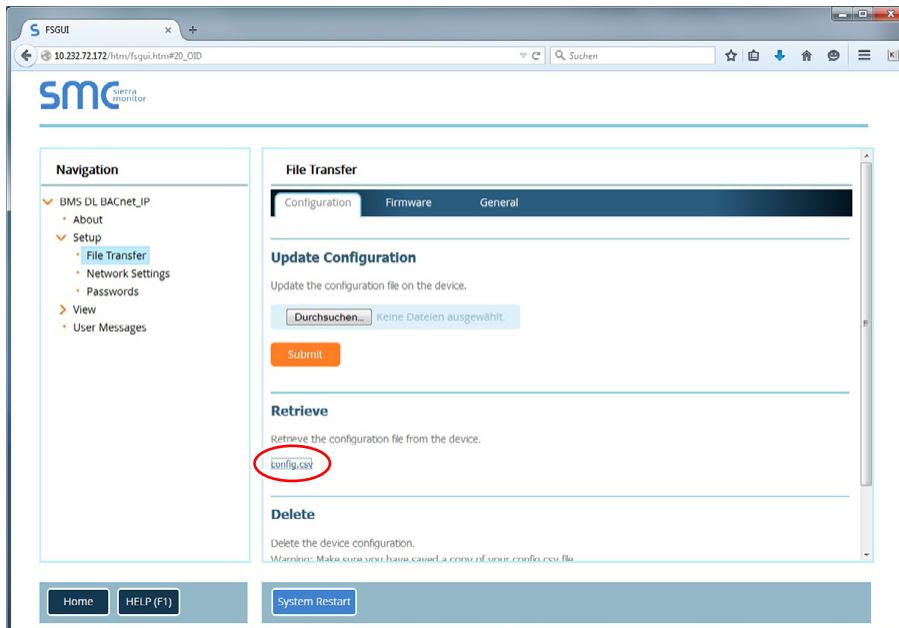

BACnet IP settings:

- 3a. Open the configuration file "config.csv" with a text editor.

- Change in the section "**Server Side Nodes**" of the window the "**Node_ID**" to the appropriate value. Range: 0...4194303

```
//=====
//  Server Side Nodes
Nodes
Node_Name,Node_ID,Protocol,Node_Offline_Response,Description
Virtual_BCU_DL,300,Bacnet_IP,Force_Normal_Response,Humidifier DL
//=====
```

- Change in the section "**Bridge**" of the window the "**Network_Number**" to the appropriate value. Default Network_Number: 101, Range: 1 - 65534.

```
//=====
//  Common Information
Bridge
Title,System_Node_Id,Network_Number
BMS DL BACnet_IP_5x,12,101
//=====
```

- Save the configuration file after all settings have been done.

BACnet MS/TP settings:

3b. Open the configuration file "config.csv" with Excel or a text editor.

- Change in the section "**Bridge**" of the window the "**System_Station_Address**" (= MAC address) to the appropriate value. Default MAC address: 127, Range: 1...127 (Master) or 1...254 (Slave).

```
Bridge
Title, System_Station_Address
BMS DL BACnet_MSTP_5x, 127
//=====================================================
```

- Change in the section "**Server Side Nodes**" of the window the "**Node_ID**" to the appropriate value. Default Node_ID: 1001, Range: 1...16777215

```
//=====
//  Server Side Nodes
Nodes
Node_Name, Node_ID, Protocol, Description
Virtual_BCU_DL, 1001, Bacnet_MSTP, Humidifier DL
//=====================================================
```

- Change in the section "**Server Side Connections**" of the window the "**Baudrate**" to the appropriate value. Default Baudrate: 9600, Options: 9600, 19200, 38400 and 76800

```
//=====
//  Server Side Connections
Connections
Port, Baud, Parity, Data_Bits, Stop_Bits, Protocol, Connection_Type
R1, 9600, None, 8, 1, Bacnet_MSTP, MSTP_Master_Mode
//=====================================================
```

- Change in the section "**Server Side Connections**" of the window the "**Parity**" to the appropriate value. Default Parity: None, Options: None, Even, Odd

```
//=====
//  Server Side Connections
Connections
Port, Baud, Parity, Data_Bits, Stop_Bits, Protocol, Connection_Type
R1, 9600, None, 8, 1, Bacnet_MSTP, MSTP_Master_Mode
//=====================================================
```

- Change a Master unit to a Slave unit if necessary: Change in the section "**Server Side Connections**" of the window the "**MSTP_Master_Mode**" to "**MSTP_Slave_Mode**". If a Master unit is changed to a Slave unit the "**System_Station_Address**" must be adjusted to a value between 1 and 254 (see first step in this section).

```
//=====
//  Server Side Connections
Connections
Port, Baud, Parity, Data_Bits, Stop_Bits, Protocol, Connection_Type
R1, 9600, None, 8, 1, Bacnet_MSTP, MSTP_Master_Mode
//=====================================================
```

- Save the configuration file after all settings have been done.

Download config.csv file:

4. Select the menu point **"Setup > File Transfer"** in the **"Navigation Tree"**. Click in the **"Update"** section on the button **<Browse...>** and select the configuration file you have modified. Then, click on the button **<Submit>** in order to upload the configuration file into the gateway board.

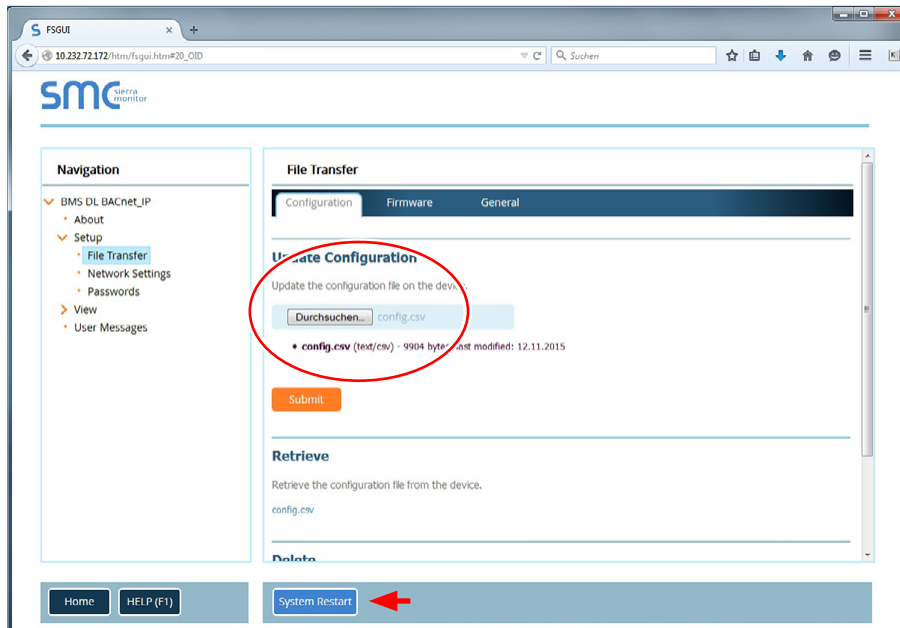

As soon as the upload is finished a corresponding message appears in the upper part of the window. Click on the button **<System Restart>** to restart the system with the new settings. After restart the Node ID or MAC address is changed to the new value.

Important: If the red LED on the gateway lights for more than 15 seconds after the download of the configuration file, a false input was done during adjustment of the configuration file! The appropriate error message can be viewed in the **"Navigation Tree"** of FS-GUI under **"User Messages > Errors"**.

4.4 Communication tables

The following table shows the gateway variables and their BACnet / LonWorks equivalents.

4.4.1 DL - BACnet (Integrated Controller software version 5.7.x.x)

Object Name	Description	Range	Object-Type	Object-ID	Read (R) Write (W)
Virtual_BCU_DL	Humidifier DL	—	DEV	300 (see chapter 4.3.2)	—
MI_HumStatus	Operating status	1 = Initializing 2 = Diagnostic 3 = Stopped 4 = Flushing 5 = Standby 6 = Flushed 7 = Humidifying 8 = Ready 9 = Refreshing 10 = Air Prs.Cleaning 11 = Filling 12 = Cond.Flush 13 = Switched Off 14 = Remote Off 15 = Regenerating	MI	01	R
MI_ServStatus	Maintenance and malfunctions status	1 = Service Info 2 = Warning 3 = Activation Code 4 = Out of Commissioning 5 = Refill Disinfection 6 = Service 7 = Fault	MI	02	R
MI_HumType	Device type	1 = Hum 2 = Hum + FC 3 = Hum + RO-C 4 = RO	MI	03	R
AI_ErrorCode	Error code ²⁾	0 = no Error	AI	01	R
AI_OperatHours	Operating hours	0 - 1'200'000 h	AI	02	R
AI_HoursToServ	Next service	0 - 10000 h	AI	03	R
AI_RHorDemand	Actual humidity or demand	0 - 100 %	AI	04	R
AI_MaxHumOut	Max. capacity ¹⁾	2 - 1000 kg/h 4 - 2573 lb/hr	AI	05	R
AI_ActCapHum	Actual capacity ¹⁾	0 - 1000 kg/h 0 - 2573 lb/hr	AI	06	R
AI_RemCapSilv	Remaining Ag-Ion capacity	0 - 58.4 Ah	AI	07	R
AI-TaAgCurrent	Target Ag-Ion current	0 - 29.2 mA	AI	08	R
AI_PressInlet	Inlet pressure PS4 ¹⁾	0 - 12.0 bar 0 - 174.0 psi	AI	09	R
AI_PressNozzle	Nozzle pressure PS5 ¹⁾	0 - 12.0 bar 0 - 174.0 psi	AI	10	R
AI_ActPermTemp	Water temperature ¹⁾	°C or °F	AI	11	R
AI_ActPermCond	Conductivity	µS/cm	AI	12	R
AI_PumpCurrent	Pump current	0 - 5.0 A	AI	13	R
AI_AgCurrent	Ag-Ion current	mA	AI	14	R

¹⁾ According to the settings <Imperial> or <Metric> in the DL controller software.

²⁾ See Error code description in the malfunction list in the DL operation manual.

Object Name	Description	Range	Object-Type	Object-ID	Read (R) Write (W)
AV_SetPointHum	Humidity setpoint	0 - 95 %	AV	01	R/W
AV_PropBand	Proportional band	6 - 65 %	AV	02	R/W
AV_IntTime	Integral time	1 - 60 min	AV	03	R/W
AV_CapLimit	Manual capacity	20 - 100 %	AV	04	R/W
AO_RemRHorDem	Actual humidity or demand via BACnet	0 - 100 % Relinquish Default = 0	AO	01	R/W

Object Name	Description	Range	Object-Type	Object-ID	Read (R) Write (W)
BI_ExtSchSta	Safety loop	0 = Open 1 = Closed (ok)	BI	01	R
BI_ValveY1	Y1 inlet valve	0 = Closed 1 = Open	BI	02	R
BI_ValveY2	Y2 valve		BI	03	R
BI_ValveY3	Y3 valve air cleaning	0 = Closed 1 = Open	BI	04	R
BI_ValveY4	Y4 valve external pipe flush	0 = Closed 1 = Open	BI	05	R
BI_StageValveY5	Y5 valve spray circuit	0 = Closed 1 = Open	BI	06	R
BI_StageValveY6	Y6 valve spray circuit	0 = Closed 1 = Open	BI	07	R
BI_StageValveY7	Y7 valve spray circuit	0 = Closed 1 = Open	BI	08	R
BI_StageValveY8	Y8 valve spray circuit	0 = Closed 1 = Open	BI	09	R
BI_StageValveY9	Y9 valve spray circuit	0 = Closed 1 = Open	BI	10	R
BI_DrainValY10	Y10 valve drain (NO)	0 = Open 1 = Closed	BI	11	R
BI_ValveY11	Y11 valve		BI	12	R
BI_Pump	FC enable	0 = Disable 1 = Enable	BI	13	R
BI_Connection	Node status	0 = Node offline 1 = Node online	BI	14	R

4.4.2 DL - LonWorks (Integrated Controller software version 5.7.x.x)

Variable Name	Description	Range	SNVT	#SNVT	Index
nviRequest	Requesting the status		SNVT_obj_request	92	0
nvoStatus	Current status		SNVT_obj_status	93	1
nvoHumStatus	Operating status	0 = Initializing 1 = Diagnostic 2 = Stopped 3 = Flushing 4 = Standby 5 = Flushed 6 = Humidifying 7 = Ready 8 = Refreshing 9 = Air Prs.Cleaning 10= Filling 11= Cond.Flush 12= Switched Off 13= Remote Off 14= Regenerating	SNVT_count	8	2
nvoServStatus	Maintenance and malfunctions status	0 = Service Info 1 = Warning 2 = Activation Code 3 = Out of Commissioning 4 = Refill Disinfection 5 = Service 6 = Fault	SNVT_count	8	3
nvoHumType	Device type	0 = Hum 1 = Hum + FC 2 = Hum + RO-C 3 = RO	SNVT_count	8	4
nvoErrorCode	Error code ²⁾	0 = no Error	SNVT_count	8	5
nvoOperatHours	Operating hours	0 - 65535 h	SNVT_time_hour	124	6
nvoHoursToServ	Next service	0 - 10000 h	SNVT_time_hour	124	7
nvoRHorDemand	Actual humidity or demand	0 - 100 %	SNVT_lev_percent	81	8
nvoMaxHumOut	Max. capacity ¹⁾	2 - 1000 kg/h 4 - 2573 lb/hr	SNVT_count_f	51	9
nvoActCapHum	Actual capacity ¹⁾	0 - 1000 kg/h 0 - 2573 lb/hr	SNVT_count_f	51	10
nvoRemCapSilv	Remaining Ag-Ion capacity	0 - 58.4 Ah	SNVT_count_f	51	11
nvoTaAgCurrent	Target Ag-Ion current	0 - 29.2 mA	SNVT_amp_mil	2	12
nvoPressInlet	Inlet pressure PS4 ¹⁾	0 - 12.0 bar 0 - 174.0 psi	SNVT_count_f	51	13
nvoPressNozzle	Nozzle pressure PS5 ¹⁾	0 - 12.0 bar 0 - 174.0 psi	SNVT_count_f	51	14
nvoActPermTemp	Water temperature ¹⁾	°C or °F	SNVT_count_f	51	15
nvoActPermCond	Conductivity	µS/cm	SNVT_count_f	51	16
nvoPumpCurrent	Pump current	0 - 5.0 A	SNVT_amp	1	17
nvoAgCurrent	Ag-Ion current	mA	SNVT_amp_mil	2	18
nvoSetPointHum nviSetPointHum	Humidity setpoint	0 - 95 %	SNVT_lev_percent	81	19 20
nvoPropBand nviPropBand	Proportional band	6 - 65 %	SNVT_lev_percent	81	21 22

Variable Name	Description	Range	SNVT	#SNVT	Index
nvoIntTime nviIntTime	Integral time	1 - 60 min	SNVT_time_min	123	23 24
nvoCapLimit nviCapLimit	Manual capacity	20 - 100 %	SNVT_lev_percent	81	25 26
nvoRemRHorDem nviRemRHorDem	Actual humidity or demand via LonWorks	0 - 100 %	SNVT_lev_percent	81	27 28

¹⁾ According to the settings <Imperial> or <Metric> in the DL controller software.

²⁾ See Error code description in the malfunction list in the DL operation manual.

Variable Name	Description	Range	SNVT	#SNVT	Index
nvoExtSChSta	Safety loop	0 = Open 1 = Closed (ok)	SNVT_switch	95	29
nvoValveY1	Y1 inlet valve	0 = Closed 1 = Open	SNVT_switch	95	30
nvoValveY2	Y2 valve	0 1	SNVT_switch	95	31
nvoValveY3	Y3 valve air cleaning	0 = Closed 1 = Open	SNVT_switch	95	32
nvoValveY4	Y4 valve external pipe flush	0 = Closed 1 = Open	SNVT_switch	95	33
nvoStageY5	Y5 valve spray circuit	0 = Closed 1 = Open	SNVT_switch	95	34
nvoStageY6	Y6 valve spray circuit	0 = Closed 1 = Open	SNVT_switch	95	35
nvoStageY7	Y7 valve spray circuit	0 = Closed 1 = Open	SNVT_switch	95	36
nvoStageY8	Y8 valve spray circuit	0 = Closed 1 = Open	SNVT_switch	95	37
nvoStageY9	Y9 valve spray circuit	0 = Closed 1 = Open	SNVT_switch	95	38
nvoDrainValY10	Y10 valve drain (NO)	0 = Open 1 = Closed	SNVT_switch	95	39
nvoValveY11	Y11 valve	0 1	SNVT_switch	95	40
nvoPump	FC enable	0 = Disable 1 = Enable	SNVT_switch	95	41
nvoConnection	Node status	0 = Node offline 1 = Node online	SNVT_switch	95	42

4.4.3 ME - BACnet (Integrated Controller software version 5.7.x.x)

Object Name	Description	Range	Object-Type	Object-ID	Read (R) Write (W)
Virtual_BCU_ME	Humidifier ME	—	DEV	410 (see chapter 4.3.2)	—
MI_HumStatus	Operating status	1 = Initializing 2 = Diagnostic 3 = Stopped 4 = Humidifying 5 = Cooling 6 = Holding 7 = Draining 8 = Refreshing 9 = Filling 10 = Standby 11 = Diluting 12 = Drain Assisting 13 = Bleeding 14 = Ramping Up 15 = Switched Off 16 = Remote Off 17 = Purging 18 = Drain Check	MI	01	R
MI_ServStatus	Maintenance and malfunctions status	1 = Service Info 2 = Warning 3 = Service 4 = Refill Liquid 5 = Replace Pure-Flow Ag+ 6 = Replace UV Bulb 7 = Matrix Wash Over 8 = Out of Commissioning 9 = Activation Code 10 = Fault	MI	02	R
AI_ErrorCode	Error code ²⁾	0 = no Error	AI	01	R
AI_OperatHours	Operating hours	0 - 1'200'000 h	AI	02	R
AI_NextSySvc	Next service	0 - 10000 h	AI	03	R
AI_NextUVSvc	Next UV bulb exchange	0 - 450 d	AI	04	R
AI_NextAgSvc	Next PureFlo Ag+ exchange	0 - 350 d	AI	05	R
AI_RHorDemand	Actual humidity or demand	0 - 100 %	AI	06	R
AI_Temp	Actual air temperature ¹⁾	°C or °F	AI	07	R
AI_UVCurrA	UV current	0 - 4.0 A	AI	08	R
AI_Stage1Cap	Water capacity stage 1 ¹⁾	5.0 - 200.0 kg/h 11.0 - 440.9 lb/h	AI	09	R
AI_Stage2Cap	Water capacity stage 2 ¹⁾	5.0 - 200.0 kg/h 11.0 - 440.9 lb/h	AI	10	R
AI_Stage3Cap	Water capacity stage 3 ¹⁾	5.0 - 200.0 kg/h 11.0 - 440.9 lb/h	AI	11	R
AI_Stage4Cap	Water capacity stage 4 ¹⁾	5.0 - 200.0 kg/h 11.0 - 440.9 lb/h	AI	12	R
AI_Stage5Cap	Water capacity stage 5 ¹⁾	5.0 - 200.0 kg/h 11.0 - 440.9 lb/h	AI	13	R
AI_Stage6Cap	Water capacity stage 6 ¹⁾	5.0 - 200.0 kg/h 11.0 - 440.9 lb/h	AI	14	R
AI_Stage7Cap	Water capacity stage 7 ¹⁾	5.0 - 200.0 kg/h 11.0 - 440.9 lb/h	AI	15	R
AI_SpeedPump1	Demand pump 1	0 - 100 %	AI	16	R
AI_SpeedPump2	Demand pump 2	0 - 100 %	AI	17	R

Object Name	Description	Range	Object-Type	Object-ID	Read (R) Write (W)
AI_SpeedPump3	Demand pump 3	0 - 100 %	AI	18	R
AI_SpeedPump4	Demand pump 4	0 - 100 %	AI	19	R
AI_SpeedPump5	Demand pump 5	0 - 100 %	AI	20	R
AI_SpeedPump6	Demand pump 6	0 - 100 %	AI	21	R
AI_SpeedPump7	Demand pump 7	0 - 100 %	AI	22	R
AI_ConductLp	Conductivity	µS	AI	23	R
AI_WtrTmp	Actual water temperature ¹⁾	°C or °F	AI	24	R
AI_AirTmp	Actual air temperature ¹⁾	°C or °F	AI	25	R
AI_NumStgAct	Number of running stages	0 - 7 stages	AI	26	R
AI_Level	Water level in tub	0 - 8	AI	27	R

¹⁾ According to the settings <Imperial> or <Metric> in the ME controller software.

²⁾ See Error code description in the malfunction list in the ME operation manual.

Object Name	Description	Range	Object-Type	Object-ID	Read (R) Write (W)
AV_SetPointHum	Humidity setpoint	0 - 95 %	AV	01	R/W
AV_PropBandH	Proportional band humidity control	6 - 65 %	AV	02	R/W
AV_IntTimeH	Integral time humidity control	1 - 60 min	AV	03	R/W
AV_SetPointTmp	Temperature setpoint ¹⁾	5 - 40 °C 41 - 104 °F	AV	04	R/W
AV_PropBandT	Proportional band temperature control ¹⁾	1 - 50 °C 34 - 122 °F	AV	05	R/W
AV_IntTimeT	Integral time temperatur control	1 - 60 min	AV	06	R/W
AV_WashAct	Matrix wash over / Tank draining	Read: 0 = Off 1 = Initialisierung 2 = Process active 3 = Process completed Write: 0 = Stop active process 1 = Start matrix wash over 2 = Start tank draining	AV	07	R/W
AO_RemRHorDem	Actual humidity or demand via BACnet	0 - 100% Relinquish Default = 0	AO	01	R/W
AO_RemTemp	Actual temperature via BACnet ¹⁾	-25 - 100 °C -13 - 212 °F Relinquish Default = 0	AO	02	R/W

¹⁾ According to the settings <Imperial> or <Metric> in the ME controller software.

Object Name	Description	Range	Object-Type	Object-ID	Read(R) Write (W)
BI_ExtSchLSta	Safety loop	0 = Open 1 = Closed (ok)	BI	01	R
BI_DosLvl	Dosing pump level	0 = Empty 1 = Ok	BI	02	R
BI_Leak	Leakage sensor	0 = Leakage 1 = Ok	BI	03	R
BI_DrainValLp	Drain valve	0 = Open 1 = Closed	BI	04	R
BI_FillValLp	Inlet valve	0 = Closed 1 = Open	BI	05	R
BI_DrainPump	Drain pump	0 = Off 1 = On	BI	06	R
BI_Pump1Err	Fault pump 1	0 = Fault 1 = Ok	BI	07	R
BI_Pump2Err	Fault pump 2	0 = Fault 1 = Ok	BI	08	R
BI_Pump3Err	Fault pump 3	0 = Fault 1 = Ok	BI	09	R
BI_Pump4Err	Fault pump 4	0 = Fault 1 = Ok	BI	10	R
BI_Pump5Err	Fault pump 5	0 = Fault 1 = Ok	BI	11	R
BI_Pump6Err	Fault pump 6	0 = Fault 1 = Ok	BI	12	R
BI_Pump7Err	Fault pump 7	0 = Fault 1 = Ok	BI	13	R
BI_InletErr	Fault water inlet	0 = Fault 1 = Ok	BI	14	R
BI_TempErr	Fault water temperature	0 = Fault 1 = Ok	BI	15	R
BI_OutletErr	Fault water outlet	0 = Fault 1 = Ok	BI	16	R
BI_LevSenErr	Fault level sensor	0 = Fault 1 = Ok	BI	17	R
BI_CondErr	Fault water conductivity	0 = Fault 1 = Ok	BI	18	R
BI_Connection	Node status	0 = Node offline 1 = Node online	BI	19	R
BV_Reset	Remote reset	0 = Off 1 = On	BV	01	R/W

4.4.4 ME- LonWorks (Integrated Controller software version 5.7.x.x)

Variable Name	Description	Range	SNVT	#SNVT	Index
nviRequest	Requesting the status		SNVT_obj_request	92	0
nvoStatus	Current status		SNVT_obj_status	93	1
nvoHumStatus	Operating status	0 = Initializing 1 = Diagnostic 2 = Stopped 3 = Humidifying 4 = Cooling 5 = Holding 6 = Draining 7 = Refreshing 8 = Filling 9 = Standby 10 = Diluting 11 = Drain Assisting 12 = Bleeding 13 = Ramping Up 14 = Switched Off 15 = Remote Off 16 = Purging 17 = Drain Check	SNVT_count	8	2
nvoServStatus	Maintenance and malfunctions status	0 = Service Info 1 = Warning 2 = Service 3 = Refill Liquid 4 = Replace PureFlow Ag+ 5 = Replace UV Bulb 6 = Matrix Wash Over 7 = Out of Commissioning 8 = Activation Code 9 = Fault	SNVT_count	8	3
nvoErrorCode	Error code ²⁾	0 = no Error	SNVT_count	8	4
nvoOperatHours	Operating hours	0 - 65535 h	SNVT_time_hour	124	5
nvoNextSySvc	Next service	0 - 10000 h	SNVT_time_hour	124	6
nvoNextUVSvc	Next UV bulb exchange	0 - 450 d	SNVT_count	8	7
nvoNextAgSvc	Next PureFlo Ag+ exchange	0 - 350 d	SNVT_count	8	8
nvoRHorDemand	Actual humidity or demand	0 - 100 %	SNVT_lev_percent	81	9
nvoTemp	Actual air temperature ¹⁾	°C or °F	SNVT_count_f	51	10
nvoUVCurrA	UV current	0 - 4.0 A	SNVT_amp	1	11
nvoStage1Cap	Water capacity stage 1 ¹⁾	5.0 - 200.0 kg/h 11.0 - 440.9 lb/h	SNVT_count_f	51	12
nvoStage2Cap	Water capacity stage 2 ¹⁾	5.0 - 200.0 kg/h 11.0 - 440.9 lb/h	SNVT_count_f	51	13
nvoStage3Cap	Water capacity stage 3 ¹⁾	5.0 - 200.0 kg/h 11.0 - 440.9 lb/h	SNVT_count_f	51	14
nvoStage4Cap	Water capacity stage 4 ¹⁾	5.0 - 200.0 kg/h 11.0 - 440.9 lb/h	SNVT_count_f	51	15
nvoStage5Cap	Water capacity stage 5 ¹⁾	5.0 - 200.0 kg/h 11.0 - 440.9 lb/h	SNVT_count_f	51	16
nvoStage6Cap	Water capacity stage 6 ¹⁾	5.0 - 200.0 kg/h 11.0 - 440.9 lb/h	SNVT_count_f	51	17
nvoStage7Cap	Water capacity stage 7 ¹⁾	5.0 - 200.0 kg/h 11.0 - 440.9 lb/h	SNVT_count_f	51	18
nvoSpeedPump1	Demand pump 1	0 - 100 %	SNVT_count	8	19
nvoSpeedPump2	Demand pump 2	0 - 100 %	SNVT_count	8	20

Variable Name	Description	Range	SNVT	#SNVT	Index
nvoSpeedPump3	Demand pump 3	0 - 100 %	SNVT_count	8	21
nvoSpeedPump4	Demand pump 4	0 - 100 %	SNVT_count	8	22
nvoSpeedPump5	Demand pump 5	0 - 100 %	SNVT_count	8	23
nvoSpeedPump6	Demand pump 6	0 - 100 %	SNVT_count	8	24
nvoSpeedPump7	Demand pump 7	0 - 100 %	SNVT_count	8	25
nvoConductLp	Conductivity	µS	SNVT_count_f	51	26
nvoWtrTmp	Actual water temperature ¹⁾	°C or °F	SNVT_count_f	51	27
nvoAirTmp	Actual air temperature ¹⁾	°C or °F	SNVT_count_f	51	28
nvoNumStgAct	Number of running stages	0 - 7 stages	SNVT_count	8	29
nvoLevel	Water level in tub	0 - 8	SNVT_count	8	30

¹⁾ According to the settings <Imperial> or <Metric> in the ME controller software.

²⁾ See Error code description in the malfunction list in the ME operation manual.

Variable Name	Description	Range	SNVT	#SNVT	Index
nvoSetPointHum nviSetPointHum	Humidity setpoint	0 - 95 %	SNVT_lev_percent	81	31 32
nvoPropBandH nviPropBandH	Proportional band humidity control	6 - 65 %	SNVT_lev_percent	81	33 34
nvoIntTimeH nviIntTimeH	Integral time humidity control	1 - 60 min	SNVT_time_min	123	35 36
nvoSetPointTmp nviSetPointTmp	Temperature setpoint ¹⁾	5 - 40 °C 41 - 104 °F	SNVT_count_f	51	37 38
nvoPropBandT nviPropBandT	Proportional band temperature control ¹⁾	1 - 50 °C 34 - 122 °F	SNVT_count_f	51	39 40
nvoIntTimeT nviIntTimeT	Integral time temperatur control	1 - 60 min	SNVT_time_min	123	41 42
nvoWashAct nviWashAct	Matrix wash over / Tank draining	Read: 0 = Off 1 = Initialisierung 2 = Process active 3 = Process completed Write: 0 = Stop active process 1 = Start matrix wash over 2 = Start tank draining	SNVT_count	8	43 44
nvoRemRHorDem nviRemRHorDem	Actual humidity or demand via Lonworks	0 - 100 %	SNVT_lev_percent	81	45 46
nvoRemTemp nviRemTemp	Actual temperature via Lonworks ¹⁾	0 - 100 °C 0 - 212 °F	SNVT_count_f	51	47 48

¹⁾ According to the settings <Imperial> or <Metric> in the ME controller software.

Variable Name	Description	Range	SNVT	#SNVT	Index
nvoExtSchLSta	Safety loop	0 = Open 1 = Closed (ok)	SNVT_switch	95	49
nvoDosLvl	Dosing pump level	0 = Empty 1 = Ok	SNVT_switch	95	50
nvoLeak	Leakage sensor	0 = Leakage 1 = Ok	SNVT_switch	95	51
nvoDrainValLp	Drain valve	0 = Open 1 = Closed	SNVT_switch	95	52
nvoFillValLp	Inlet valve	0 = Closed 1 = Open	SNVT_switch	95	53
nvoDrainPump	Drain pump	0 = Off 1 = On	SNVT_switch	95	54
nvoPump1Err	Fault pump 1	0 = Fault 1 = Ok	SNVT_switch	95	55
nvoPump2Err	Fault pump 2	0 = Fault 1 = Ok	SNVT_switch	95	56
nvoPump3Err	Fault pump 3	0 = Fault 1 = Ok	SNVT_switch	95	57
nvoPump4Err	Fault pump 4	0 = Fault 1 = Ok	SNVT_switch	95	58
nvoPump5Err	Fault pump 5	0 = Fault 1 = Ok	SNVT_switch	95	59
nvoPump6Err	Fault pump 6	0 = Fault 1 = Ok	SNVT_switch	95	60
nvoPump7Err	Fault pump 7	0 = Fault 1 = Ok	SNVT_switch	95	61
nvoInletErr	Fault water inlet	0 = Fault 1 = Ok	SNVT_switch	95	62
nvoTempErr	Fault water temperature	0 = Fault 1 = Ok	SNVT_switch	95	63
nvoOutletErr	Fault water outlet	0 = Fault 1 = Ok	SNVT_switch	95	64
nvoLevSenErr	Fault level sensor	0 = Fault 1 = Ok	SNVT_switch	95	65
nvoCondErr	Fault water conductivity	0 = Fault 1 = Ok	SNVT_switch	95	66
nvoConnection	Node status	0 = Node offline 1 = Node online	SNVT_switch	95	67
nvoReset	Remote reset	0 = Off	SNVT_switch	95	68
nviReset		1 = On			69

4.4.5 RS - BACnet (Integrated Controller software version 5.7.x.x)

Object Name	Description	Range	Object-Type	Object-ID	Read (R) Write (W)
Virtual_BCU_RS	Humidifier RS	—	DEV	710 (see chapter 4.3.2)	—
MI_UnitStatusA	Operating status unit A	1 = Initializing 2 = Diagnostic 3 = Stopped 4 = Break 5 = Level test 6 = Standby 7 = Humidifying 8 = Filling 9 = Idle 10 = Draining 11 = Remote off 12 = Keep Warm	MI	01	R
MI_UnitStatusB	Operating status unit B	1 = Initializing 2 = Diagnostic 3 = Stopped 4 = Break 5 = Level test 6 = Standby 7 = Humidifying 8 = Filling 9 = Idle 10 = Draining 11 = Remote off 12 = Keep Warm	MI	02	R
MI_ServStatusA	Maintenance and malfunctions status unit A	1 = Service Info 2 = Warning 3 = RO Service 4 = Extended Maint. 5 = Small Maint. 6 = Activation Code 7 = Fault	MI	03	R
MI_ServStatusB	Maintenance and malfunctions status unit B	1 = Service Info 2 = Warning 3 = RO Service 4 = Extended Maint. 5 = Small Maint. 6 = Activation Code 7 = Fault	MI	04	R
MI_HumType	Device type	1 = RS 2 = RS+ RO 3 = RO	MI	05	R
MI_NomVoltage	Nominal voltage	1 = 200 V 2 = 208 V 3 = 230 V 4 = 240 V 5 = 400 V 6 = 415 V 7 = 440 V 8 = 460 V 9 = 480 V 10 = 500 V 11 = 550 V 12 = 600 V 13 = 380 V	MI	06	R
MI_LevelA	Water level unit A	1 = no level 2 = low 3 = low-mid 4 = mid 5 = mid-high 6 = high	MI	07	R

Object Name	Description	Range	Object-Type	Object-ID	Read (R) Write (W)
MI_LevelB	Water level unit B	1 = no level 2 = low 3 = low-mid 4 = mid 5 = mid-high 6 = high	MI	08	R
AI_ErrorCode	Error code ²⁾	0 = No Error	AI	01	R
AI_OperatHours	Operating hours	0 - 1'200'000 h	AI	02	R
AI_HoursToServA	Next service unit A	0 - 6000 h	AI	03	R
AI_HoursToServB	Next service unit B		AI	04	R
AI_SystemDemand	System demand	0 - 100 %	AI	05	R
AI_InputA1	Input signal channel 1 unit A	0 - 100 %	AI	06	R
AI_InputA2	Limiter signal channel 2 unit A	0 - 100 %	AI	07	R
AI_MaxHumOut	Max. capacity ¹⁾	5 - 160 kg/h 10 - 360 lb/hr	AI	08	R
AI_CylMaxCapA	Max. capacity unit A ¹⁾	5 - 40 kg/h 10 - 90 lb/hr	AI	09	R
AI_CylMaxCapB	Max. capacity unit B ¹⁾	5 - 40 kg/h 10 - 90 lb/hr	AI	10	R
AI_ActCapHum	Actual capacity ¹⁾	0 - 160 kg/h 0 - 360 lb/hr	AI	11	R
AI_CylActCapA	Actual capacity unit A ¹⁾	0 - 40 kg/h 0 - 90 lb/hr	AI	12	R
AI_CylActCapB	Actual capacity unit B ¹⁾	0 - 40 kg/h 0 - 90 lb/hr	AI	13	R

¹⁾ According to the settings <Imperial> or <Metric> in the RS controller software.

²⁾ See Error code description in the malfunction list in the RS operation manual.

Object Name	Description	Range	Object-Type	Object-ID	Read (R) Write (W)
AV_SetPointA1	Setpoint channel 1 unit A	0 - 95 %	AV	01	R/W
AV_SetPointA2	Setpoint channel 2 limiter unit A	10 - 95 %	AV	02	R/W
AV_PropBandA1	P-Band unit A (proportional band)	6 - 65 %	AV	03	R/W
AV_PropBandA2	P-Band limiter unit A (Proportional band)	6 - 65 %	AV	04	R/W
AV_IntTimeA1	Integral time channel 1 unit A	1 - 60 min	AV	05	R/W
AV_DampTimeA2	Damp time channel 2 unit A	0 - 60 s	AV	06	R/W
AV_CapLimitA	Manual capacity unit A	20 - 100 %	AV	07	R/W

Object Name	Description	Range	Object-Type	Object-ID	Read (R) Write (W)
AV_RemoteDrain	Remote drain	Read: 0= Off 1=Init 2=busy 3=done Write 0=Off 1= RS drain cylinder A 2= RS drain cylinder B 3= RS drain cyl. A+B 4 = RO flush 5 = RO fresh water automation	AV	08	R/W
AO_RemRHorDemA1	Actual humidity or demand via BACnet unit A	0 - 100 % Relinquish Default = 0	AO	01	R/W
AO_RemRHorDemA2	Actual humidity or limiter via BACnet unit A	0 - 100 % Relinquish Default = 0	AO	02	R/W

Object Name	Description	Range	Object-Type	Object-ID	Read (R) Write (W)
BI_BlowerPackA	Blower ready unit A	0 = Off 1 = On (ready)	BI	01	R
BI_BlowerPackB	Blower ready unit B	0 = Off 1 = On (ready)	BI	02	R
BI_ExtSChStaA	External safety loop unit A	0 = Open 1 = Closed (ok)	BI	03	R
BI_ExtSChStaB	External safety loop unit B	0 = Open 1 = Closed (ok)	BI	04	R
BI_IntSChStaA	Internal safety loop unit A	0 = Open 1 = Closed (ok)	BI	05	R
BI_IntSChStaB	Internal safety loop unit B	0 = Open 1 = Closed (ok)	BI	06	R
BI_HeatVoltageA	Heating voltage unit A	0 = Off 1 = On	BI	07	R
BI_HeatVoltageB	Heating voltage unit B	0 = Off 1 = On	BI	08	R
BI_LevelSafetyA	Internal safety loop unit A (security level)	0 = Off 1 = On (ok)	BI	09	R
BI_LevelSafetyB	Internal safety loop unit B (security level)	0 = Off 1 = On (ok)	BI	10	R
BI_LeakA	Leakage sensor unit A	0 = Off (Leak) 1 = On	BI	11	R
BI_LeakB	Leakage sensor unit B	0 = Off (Leak) 1 = On	BI	12	R
BI_MainContactA	Contacteur unit A	0 = Off 1 = On	BI	13	R
BI_MainContactB	Contacteur unit B	0 = Off 1 = On	BI	14	R
BI_PumpA	Pump unit A	0 = Off 1 = On	BI	15	R
BI_PumpB	Pump unit B	0 = Off 1 = On	BI	16	R

Object Name	Description	Range	Object-Type	Object-ID	Read (R) Write (W)
BI_InletA1	Inlet valve 1 unit A	0 = Closed 1 = Open	BI	17	R
BI_InletB1	Inlet valve 1 unit B	0 = Closed 1 = Open	BI	18	R
BI_InletA2	Inlet valve 2 unit A	0 = Closed 1 = Open	BI	19	R
BI_InletB2	Inlet valve 2 unit B	0 = Closed 1 = Open	BI	20	R
BI_DrainA1	Drain cool valve unit A	0 = Closed 1 = Open	BI	21	R
BI_DrainB1	Drain cool valve unit B	0 = Closed 1 = Open	BI	22	R
BI_DrainA2	Complete drain valve unit A	0 = Closed 1 = Open	BI	23	R
BI_DrainB2	Complete drain valve unit B	0 = Closed 1 = Open	BI	24	R
BI_FanA	External fan unit A	0 = Off 1 = On	BI	25	R
BI_FanB	External fan unit B	0 = Off 1 = On	BI	26	R
BI_FlushValveA	Hygiene flush unit A	0 = Closed 1 = Open	BI	27	R
BI_FlushValveB	Hygiene flush unit B	0 = Closed 1 = Open	BI	28	R
BI_Connection	Node status	0 = Node offline 1 = Node online	BI	29	R

4.4.6 RS - LonWorks (Integrated Controller software version 5.7.x.x)

Variable Name	Description	Range	SNVT	#SNVT	Index
nviRequest	Requesting the status		SNVT_obj_request	92	0
nvoStatus	Current status		SNVT_obj_status	93	1
nvoUnitStatusA	Operating status unit A	0 = Initializing 1 = Diagnostic 2 = Stopped 3 = Break 4 = Level test 5 = Standby 6 = Humidifying 7 = Filling 8 = Idle 9 = Draining 10 = Remote off 11 = Keep Warm	SNVT_count	8	2
nvoUnitStatusB	Operating status unit B	0 = Initializing 1 = Diagnostic 2 = Stopped 3 = Break 4 = Level test 5 = Standby 6 = Humidifying 7 = Filling 8 = Idle 9 = Draining 10 = Remote off 11 = Keep Warm	SNVT_count	8	3
nvoServStatusA	Maintenance and malfunctions status unit A	0 = Service Info 1 = Warning 2 = RO Service 3 = Extended Maint. 4 = Small Maint. 5 = Activation Code 6 = Fault	SNVT_count	8	4
nvoServStatusB	Maintenance and malfunctions status unit B	0 = Service Info 1 = Warning 2 = RO Service 3 = Extended Maint. 4 = Small Maint. 5 = Activation Code 6 = Fault	SNVT_count	8	5
nvoHumType	Device type	0 = RS 1 = RS+ RO 2 = RO	SNVT_count	8	6
nvoNomVoltage	Nominal voltage	0 = 200 V 1 = 208 V 2 = 230 V 3 = 240 V 4 = 400 V 5 = 415 V 6 = 440 V 7 = 460 V 8 = 480 V 9 = 500 V 10 = 550 V 11 = 600 V 12 = 380 V	SNVT_volt	44	7
nvoLevelA	Water level unit A	0 = no level 1 = low 2 = low-mid 3 = mid 4 = mid-high 5 = high	SNVT_count	8	8

Variable Name	Description	Range	SNVT	#SNVT	Index
nvoLevelB	Water level unit B	0 = no level 1 = low 2 = low-mid 3 = mid 4 = mid-high 5 = high	SNVT_count	8	9
nvoErrorCode	Error code ²⁾	0 = No Error	SNVT_count	8	10
nvoOperatHours	Operating hours	0 - 65535 h	SNVT_time_hour	124	11
nvoHoursToServA	Next service unit A	0 - 6000 h	SNVT_time_hour	124	12
nvoHoursToServB	Next service unit B		SNVT_time_hour	124	13
nvoSystemDemand	System demand	0 - 100 %	SNVT_lev_percent	81	14
nvoInputA1	Input signal channel 1 unit A	0 - 100 %	SNVT_lev_percent	81	15
nvoInputA2	Limiter signal channel 2 unit A	0 - 100 %	SNVT_lev_percent	81	16
nvoMaxHumOut	Max. capacity ¹⁾	5 - 160 kg/h 10 - 360 lb/hr	SNVT_count_f	51	17
nvoCylMaxCapA	Max. capacity unit A ¹⁾	5 - 40 kg/h 10 - 90 lb/hr	SNVT_count_f	51	18
nvoCylMaxCapB	Max. capacity unit B ¹⁾	5 - 40 kg/h 10 - 90 lb/hr	SNVT_count_f	51	19
nvoActCapHum	Actual capacity ¹⁾	0 - 160 kg/h 0 - 360 lb/hr	SNVT_count_f	51	20
nvoCylActCapA	Actual capacity unit A ¹⁾	0 - 40 kg/h 0 - 90 lb/hr	SNVT_count_f	51	21
nvoCylActCapB	Actual capacity unit B ¹⁾	0 - 40 kg/h 0 - 90 lb/hr	SNVT_count_f	51	22

¹⁾ According to the settings <Imperial> or <Metric> in the RS controller software.

²⁾ See Error code description in the malfunction list in the RS operation manual.

Variable Name	Description	Range	SNVT	#SNVT	Index
nvoSetPointA1 nviSetPointA1	Setpoint channel 1 unit A	0 - 95 %	SNVT_lev_percent	81	23 24
nvoSetPointA2 nviSetPointA2	Setpoint channel 2 limiter unit A	10 - 95 %	SNVT_lev_percent	81	25 26
nvoPropBandA1 nviPropBandA1	P-Band unit A (Proportional band)	6 - 65 %	SNVT_lev_percent	81	27 28
nvoPropBandA2 nviPropBandA2	P-Band limiter unit A (Proportional band)	6 - 65 %	SNVT_lev_percent	81	29 30
nvoIntTimeA1 nviIntTimeA1	Integral time channel 1 unit A	1 - 60 min	SNVT_time_min	123	31 32
nvoDampTimeA2 nviDampTimeA2	Damp time channel 2 unit A	0 - 60 s	SNVT_time_sec	107	33 34
nvoCapLimitA nviCapLimitA	Manual capacity unit A	20 - 100 %	SNVT_lev_percent	81	35 36

Variable Name	Description	Range	SNVT	#SNVT	Index
nvoRemoteDrain nviRemoteDrain	Remote Drain	Read: 0 = Off 1 = Init 2 = busy 3 = done Write 0 = Off 1 = RS drain cylinder A 2 = RS drain cylinder B 3 = RS drain cyl. A+B 4 = RO flush 5 = RO fresh water automation	SNVT_count	8	37 38
nvoRemRHorDemA1 nviRemRHorDemA1	Actual humidity or demand via Lonworks unit A	0 - 100 %	SNVT_lev_percent	81	39 40
nvoRemRHorDemA2 nviRemRHorDemA2	Actual humidity or limiter via Lonworks unit A	0 - 100 %	SNVT_lev_percent	81	41 42

Variable Name	Description	Range	SNVT	#SNVT	Index
nvoBlowerPackA	Blower ready unit A	0 = Off 1 = On (ready)	SNVT_switch	95	43
nvoBlowerPackB	Blower ready unit B	0 = Off 1 = On (ready)	SNVT_switch	95	44
nvoExtSChStaA	External safety loop unit A	0 = Open 1 = Closed (ok)	SNVT_switch	95	45
nvoExtSChStaB	External safety loop unit B	0 = Open 1 = Closed (ok)	SNVT_switch	95	46
nvoIntSChStaA	Internal safety loop unit A	0 = Open 1 = Closed (ok)	SNVT_switch	95	47
nvoIntSChStaB	Internal safety loop unit B	0 = Open 1 = Closed (ok)	SNVT_switch	95	48
nvoHeatVoltageA	Heating voltage unit A	0 = Off 1 = On	SNVT_switch	95	49
nvoHeatVoltageB	Heating voltage unit B	0 = Off 1 = On	SNVT_switch	95	50
nvoLevelSafetyA	Internal safety loop unit A (security level)	0 = Off 1 = On (ok)	SNVT_switch	95	51
nvoLevelSafetyB	Internal safety loop unit B (security level)	0 = Off 1 = On (ok)	SNVT_switch	95	52
nvoLeakA	Leakage sensor unit A	0 = Off (Leak) 1 = On	SNVT_switch	95	53
nvoLeakB	Leakage sensor unit B	0 = Off (Leak) 1 = On	SNVT_switch	95	54
nvoMainContactA	Contact unit A	0 = Off 1 = On	SNVT_switch	95	55
nvoMainContactB	Contact unit B	0 = Off 1 = On	SNVT_switch	95	56
nvoPumpA	Pump unit A	0 = Off 1 = On	SNVT_switch	95	57
nvoPumpB	Pump unit B	0 = Off 1 = On	SNVT_switch	95	58
nvoInletA1	Inlet valve 1 unit A	0 = Closed 1 = Open	SNVT_switch	95	59
nvoInletB1	Inlet valve 1 unit B	0 = Closed 1 = Open	SNVT_switch	95	60

Variable Name	Description	Range	SNVT	#SNVT	Index
nvoInletA2	Inlet valve 2 unit A	0 = Closed 1 = Open	SNVT_switch	95	61
nvoInletB2	Inlet valve 2 unit B	0 = Closed 1 = Open	SNVT_switch	95	62
nvoDrainA1	Drain cool valve unit A	0 = Closed 1 = Open	SNVT_switch	95	63
nvoDrainB1	Drain cool valve unit B	0 = Closed 1 = Open	SNVT_switch	95	64
nvoDrainA2	Complete drain valve unit A	0 = Closed 1 = Open	SNVT_switch	95	65
nvoDrainB2	Complete drain valve unit B	0 = Closed 1 = Open	SNVT_switch	95	66
nvoFanA	External fan unit A	0 = Off 1 = On	SNVT_switch	95	67
nvoFanB	External fan unit B	0 = Off 1 = On	SNVT_switch	95	68
nvoFlushValveA	Hygiene flush unit A	0 = Closed 1 = Open	SNVT_switch	95	69
nvoFlushValveB	Hygiene flush unit B	0 = Closed 1 = Open	SNVT_switch	95	70
nvoConnection	Node status	0 = Node offline 1 = Node online	SNVT_switch	95	71

4.5 Troubleshooting

4.5.1 Operating trouble list

Problem	Solutions
Cannot see/change set object/parameter from BMS	<p>Check "Control Mode" setting in the "Control Settings" submenu.</p> <ul style="list-style-type: none"> – Demand type controls use internal algorithms to generate a signal telling the Condair Integrated Controller to operate at a certain output percentage. These types of controls do not report the detected humidity or temperature level or set point to the Condair Integrated Controller. As a result the set point and humidity/temperature levels cannot be monitored through the Condair Integrated Controller when using demand controls. – Sensor ("transducer") type controls report a sensed humidity/temperature value to the Condair Integrated Controller. The set point is configured at the control unit and the Condair Integrated Controller uses internal algorithms to determine the output percentage. Since the Condair Integrated Controller knows both the set point and humidity/temperature level, these values may be monitored through the Condair Integrated Controller. <p>Note: "Control mode" must be set to "rH P" or "rH PI".</p>
Cannot establish communication	<ul style="list-style-type: none"> – Check communication parameters (see chapter 4.3.1.3). – Check if the jumper J7 is removed. – Verify Hardware connections from BMS to BACnet or LonWorks gateway board (see chapter 4.2.2). – With BACnet IP: Check the IP address, subnet mask and default gateway. These parameters must be in the same range as the client (client = BACnet device, for example a building controller or workstation requesting data from the humidifier) Check if other network participants or firewalls are blocking BACnet messages. – With BACnet MS/TP Master: Check the MAC address. This should be in the range 0-127. The value in the Device Object property "Max Master" must be equal to or higher than the MAC address.. – With BACnet MS/TP Slave: MS/TP slave devices can not be detected automatically via the "Who-is" BACnet service and therefore have to be manually added to the network.
Cannot read data	<ul style="list-style-type: none"> – Check correct using of data type on the BMS.

Problem	Solutions
Only some objects/parameters report data	<ul style="list-style-type: none"> – Check the baud rate being used on the BMS network. Use of faster baud rates may assist. – Check the polling rate being used. High polling rates can cause data collision. A recommended polling rate is once per minute. – Check the software version of the intergrated controller. The configuration on the gateway board must match with the software version of intergrated controller.
Condair Integrated Controller will not respond to set point/sensor values/ demand values written over BACnet/ LonWorks.	<ul style="list-style-type: none"> – Check that Condair Integrated Controller is configured to be controlled via automation system (see chapter 4.3.1.1). Note: If "Source" in the controller settings is set to "Analog" the Condair Integrated Controller will look for a control signal connected to the driver board only.
"MI_HumStatus" or "MI_UnitStatusA" show always "Initializing"	<p>Probably the communication between humidfier and gateway is interrupted!</p> <ul style="list-style-type: none"> – Check the communication parameters (see chapter 4.3.1.3). – Ensure Jumper J7 is removed. – Ensure the gateway board is correctly inserted into the socket of the Integrated Controller.
"MI_UnitStatusB" shows always "Initializing"	<ul style="list-style-type: none"> – Check whether a B unit is present. Note: if only a A unit is operated the objects for the B unit are inactive. The text "Initializing" in "MI_UnitStatusB" is ok if no B unit exists.
The device will not respond to control signal connected to the driver board.	<ul style="list-style-type: none"> – Check that "Signal Source" in the controller settings is configured for "Analog" control. Note: If the "Signal Source" is set to "Modbus", the Condair Integrated Controller will look for a control value sent by the BMS.
Intermittent Communications.	<ul style="list-style-type: none"> – Check whether the wire type and run length meet the requirements of the corresponding network. – Look for wire runs in close proximity to equipment generating significant electrical noise (such as VFD's, medical equipment, X-ray machinery, servers, etc). – Check that wire shield is terminated at one end only. – Confirm correct polarity of conductors at each device. – Check BACnet/LonWorks addresses for conflicts with any device. Note: Each device on the network must have a unique address.
Invalid data	<ul style="list-style-type: none"> – Check BACnet/LonWorks addresses for conflicts with any device. Note: Each device on the network must have a unique address. – Check correct setting of Modbus parameter <Register sequence> according to chapter 4.3.1.3.
Error code "0" is shown though a fault is present on the Integrated Controller.	<ul style="list-style-type: none"> – Check software version of the Integrated Controller. Error code indication is not supported with software version 1.x.x.x.

Problem	Solutions
Wrong values (e.g. temperature, pressure, mass flow) are shown via BMS.	<ul style="list-style-type: none"> – Check software version of the Integrated Controller. – Check the "Units" setting in the "General" menu.
Meaningless values outside the expected value range are displayed.	<ul style="list-style-type: none"> – Check the register order in the menu "Communication > Modbus Parameters". The register order must be set to "MSR First".
Humidifier type is not shown on top of the navigation tree of the FS-GUI.	<ul style="list-style-type: none"> – Probably the configuration has not been uploaded into the gateway board. Contact Condair Technical Services for additional support.
More variables or additional information is required from the Condair Integrated Controller.	<ul style="list-style-type: none"> – Contact Condair Technical Services for additional support.
The "Units" property is not defined for all BACnet objects, although the BACnet standard lists these units.	<ul style="list-style-type: none"> – BACnet objects that have units which differ depending on the setting "Metric" or "Imperial" are not fixed implemented. These include units such as temperature (°C or °F), pressure (bar or psi), mass flow (kg/h or lbs/hr).

4.5.2 LED functions



Abb. 10: BACnet IP / BACnet MS/TP LED's

LED	Description
HEART BEAT (amber)	The system indicator LED as indication that the operating system is running
ERROR (red)	The ERROR LED lights up on power up and goes off 15 seconds after power up. A steady red light will indicate there is a system error on the gateway board. The related "system error" is shown in the "User Messages / error screen" of the FS-GUI interface.
NODE OFF-LINE (amber)	The Node Offline LED lights up on power up and goes off 15 seconds after power up. If the Node Offline LED stays on solid, a Node Offline condition has occurred (no communication between Intergrated Controller and gateway, check Modbus settings of the integrated Controller, and ensure that Jumper J7 has been removed).
RUN (green)	The RUN LED will start flashing 20 seconds after power indicating normal operation. The board will be able to access FS-GUI once this LED starts flashing.
TX	RS-485 indicator LED when a message is sent through the port.
RX	RS-485 indicator LED when a message is received by the port.

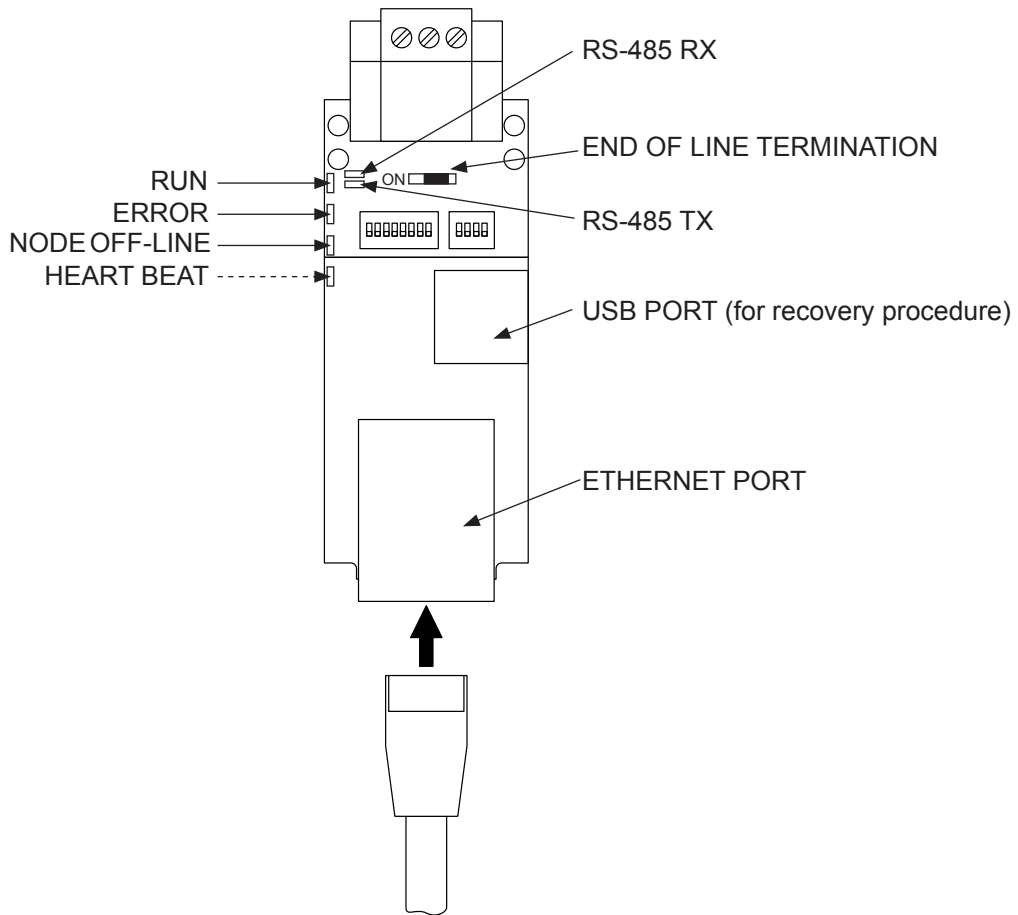

Abb. 11: LonWorks LED's

LED	Description
HEART BEAT (amber)	The system indicator LED as indication that the operating system is running
ERROR (red)	The ERROR LED lights up on power up and goes off 15 seconds after power up. A steady red light will indicate there is a system error on the gateway board. The related "system error" is shown in the "User Messages / error screen" of the FS-GUI interface.
NODE OFF-LINE (amber)	The Node Offline LED lights up on power up and goes off 15 seconds after power up. If the Node Offline LED stays on solid, a Node Offline condition has occurred (no communication between Integrated Controller and gateway or no network output variable (nvo) of the LonWorks gateway has been binded to a network input variable of another Lon device). Check whether binding has been done, check the Modbus settings of the Integrated Controller, and ensure that Jumper J7 has been removed.
RUN (green)	The RUN LED will start flashing 20 seconds after power indicating normal operation. The board will be able to access FS-GUI once this LED starts flashing.

LED	Description
PWR (green)	This is the power light and should show steady green at all times when the board is powered.
LON-TX LED	On normal operation of the board, the TX LED will flash when a message is sent on the Lon port of the board.
LON-RX LED	On normal operation of the board, the RX LED will flash when a message is received on the Lon port of the board.
LON SERVICE LED (next to Lon port)	The LON SERVICE LED will flash if the board is configured for implicit addressing and not commissioned. LED will be off if the board is configured for implicit addressing and commissioned or if it is configured for explicit addressing.

5 Appendix

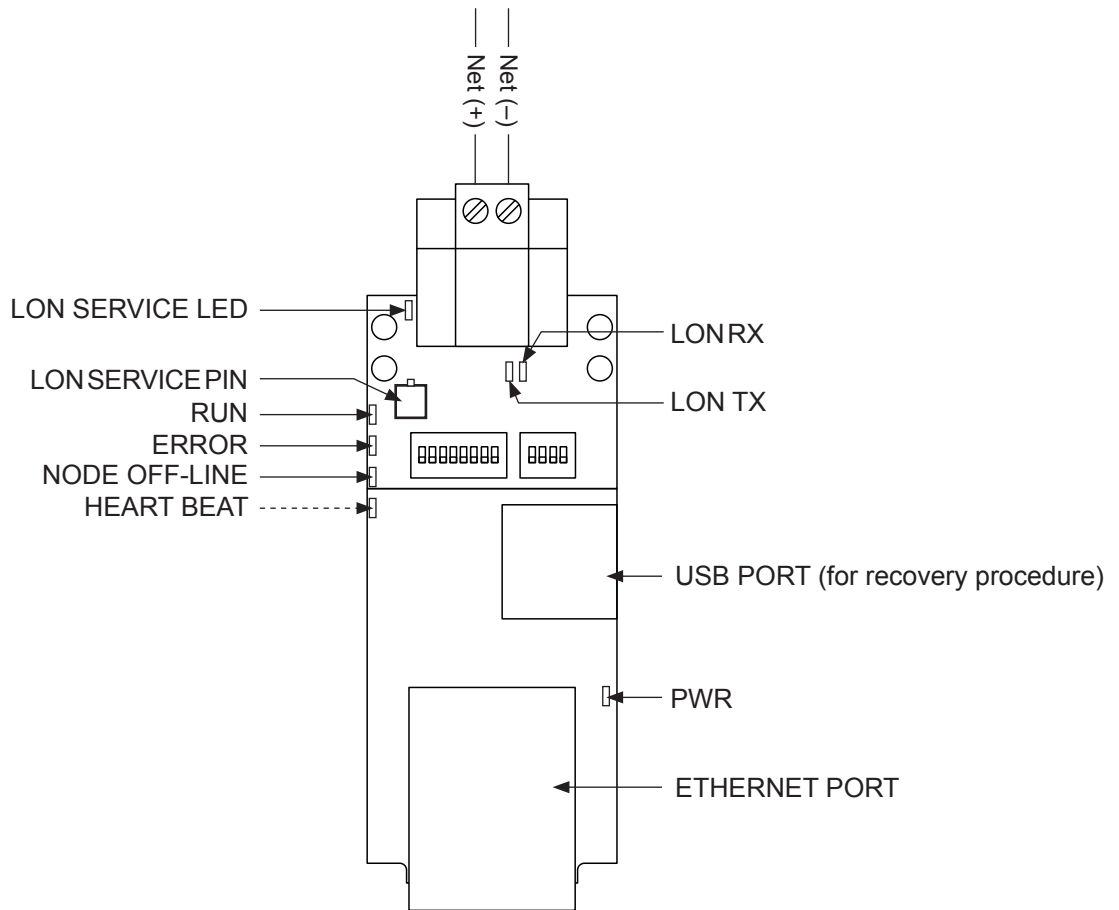
5.1 Object abbreviations

AI = Analog Input	Analog value, readable
AO = Analog Output	Analogue control signal, readable and writable (with priority)
AV = Analog Value	Analogue setting, readable and writable
BI = Binär Input	Binary state value, readable
BV = Binär Value	Binary value, readable and writable
MI = Multistate Input	Multistate status value, readable



Attention: Date:
 Company: Fax #:
 From: Page: of
 Subject:

FOR YOUR INFORMATION RESPONSE REQUESTED

MESSAGE:

Distributor / Agent P.O. Number: Sales Order Number:

Desired interface option:

- BACnet IP
- BACnet MS/TP
- LonWorks

Settings for BACnet only:

- Default Gateway Address/Name:
- BACnet Node ID (Device Instance):.....
- Network Number:
- Subnet Mask:
- Module IP Address:

Settings for BACnet MS/TP only:

- MAC Address BACnet MS/TP:.....
- Baud rate:.....

U.S.A.
 835 Commerce Park Drive
 Ogdensburg, New York 13669

CANADA
 2740 Fenton Road
 Ottawa, Ontario K1T 3T7

TEL: 1.866.667.8321
 FAX: 613.822.7964

EMAIL: na.info@condair.com
 WEBSITE: www.condair.com

Warranty

Condair Inc. and/or Condair Ltd. (hereinafter collectively referred to as THE COMPANY), warrant for a period of two years after installation or 30 months from manufacturer's ship date, whichever date is earlier, that THE COMPANY's manufactured and assembled products, not otherwise expressly warranted (with the exception of the cylinder), are free from defects in material and workmanship. No warranty is made against corrosion, deterioration, or suitability of substituted materials used as a result of compliance with government regulations.

THE COMPANY's obligations and liabilities under this warranty are limited to furnishing replacement parts to the customer, F.O.B. THE COMPANY's factory, providing the defective part(s) is returned freight prepaid by the customer. Parts used for repairs are warranted for the balance of the term of the warranty on the original humidifier or 90 days, whichever is longer.

The warranties set forth herein are in lieu of all other warranties expressed or implied by law. No liability whatsoever shall be attached to THE COMPANY until said products have been paid for in full and then said liability shall be limited to the original purchase price for the product. Any further warranty must be in writing, signed by an officer of THE COMPANY.

THE COMPANY's limited warranty on accessories, not of the companies manufacture, such as controls, humidistats, pumps, etc. is limited to the warranty of the original equipment manufacturer from date of original shipment of humidifier.

THE COMPANY makes no warranty and assumes no liability unless the equipment is installed in strict accordance with a copy of the catalog and installation manual in effect at the date of purchase and by a contractor approved by THE COMPANY to install such equipment.

THE COMPANY makes no warranty and assumes no liability whatsoever for consequential damage or damage resulting directly from misapplication, incorrect sizing or lack of proper maintenance of the equipment.

THE COMPANY makes no warranty and assumes no liability whatsoever for damage resulting from freezing of the humidifier, supply lines, drain lines, or steam distribution systems.

THE COMPANY retains the right to change the design, specification and performance criteria of its products without notice or obligation.



U.S.A.
835 Commerce Park Drive
Ogdensburg, New York 13669

CANADA
2740 Fenton Road
Ottawa, Ontario K1T 3T7

TEL: 1.866.667.8321
FAX: 613.822.7964

EMAIL: na.info@condair.com
WEBSITE: www.condair.com

