

READ AND SAVE THESE INSTRUCTIONS

INSTALLATION MANUAL

Adiabatic air humidification/air cooling system
Condair **ME Control**

Thank you for choosing Condair

Installation date (MM/DD/YYYY):

Commissioning date (MM/DD/YYYY):

Site:

Model:

Serial number:

Contact

Condair Ltd.
2740 Fenton Road, Ottawa, Ontario K1T3T7
TEL: 1.866.667.8321, FAX: 613.822.7964
EMAIL: na.info@condair.com, WEBSITE: www.condair.com

Proprietary Notice

This document and the information disclosed herein are proprietary data of Condair Ltd. Neither this document, nor the information contained herein shall be reproduced, used, or disclosed to others without the written authorization of Condair Ltd., except to the extent required for installation or maintenance of recipient's equipment.

Liability Notice

Condair Ltd. does not accept any liability due to incorrect installation or operation of the equipment or due to the use of parts/components/equipment that are not authorized by Condair Ltd.

Copyright Notice

© Condair Ltd., All rights reserved.

Technical modifications reserved

Contents

1	Introduction	4
1.1	General	4
1.2	Notes on the installation manual	4
2	For your safety	6
3	Important notes	8
3.1	Inspection of the delivery	8
3.2	Storing/Transportation/Packaging	8
3.3	Product designation / Which model do you have	9
3.4	UL approved installation	9
4	Installation	10
4.1	Installation overviews	10
4.1.1	Typical installation Condair ME Control (internal installation)	10
4.1.2	Typical installation Condair ME Control (external installation)	11
4.2	Mounting the evaporative module	12
4.2.1	Notes on positioning the evaporative module	12
4.2.2	Installation procedure evaporative module	14
4.3	Mounting the hydraulic modules	27
4.3.1	Mounting the hydraulic modules (internal installation)	27
4.3.2	Mounting the hydraulic modules (external installation)	28
4.4	Mounting the wall feed through plates	31
4.5	Water installation	35
4.5.1	Notes on water installation	35
4.5.2	Water installation (internal installation)	38
4.5.3	Water installation (external installation)	39
4.5.4	Mounting the control unit	40
4.5.5	Notes on positioning the control unit	40
4.5.6	Recommended access requirements of the control unit	40
4.5.7	Mounting the control unit	41
4.6	Electrical installation	42
4.6.1	Notes on electrical installation	42
4.6.2	Wiring diagram Condair ME Control	44
4.6.3	Installation work	46
5	Appendix	52
5.1	Inlet water quality requirements	52

1 Introduction

1.1 General

We thank you for having purchased the **Condair ME Control Evaporative Humidifier and Cooler** (Condair ME Control for short).

To ensure a safe, proper, and economical operation of the Condair ME Control, please observe and comply with all information and safety instructions contained in the present documentation as well as in the separate documentations of the components installed in the humidification system. Improper use of the Condair ME Control may result in danger to the user or third parties and/or impairment of material assets.

If you have questions after reading this documentation, please contact your Condair representative. They will be glad to assist you.

1.2 Notes on the installation manual

Limitation

The subject of this installation manual is the Condair ME Control Evaporative Humidifier and Cooler. The various options and accessories are only described insofar as is necessary for proper operation of the equipment. Further information on options and accessories can be obtained in the respective instructions.

This installation manual is restricted to the **installation** of the Condair ME Control and is meant for **well trained personnel being sufficiently qualified for their respective work**.

Please note, some illustrations in this manual may show options and accessories which may not be supplied as standard or available in your country. Please check availability and specification details with your Condair representative.

The installation manual is supplemented by various separate items of documentation (such as the operation manual), which are included in the delivery as well. Where necessary, appropriate cross-references are made to these publications in the installation manual.

Symbols used in this manual



CAUTION!

The catchword "CAUTION" used in conjunction with the general caution symbol designates notes in this installation manual that, if neglected, may cause **damage and/or malfunction of the unit or other material assets**.



WARNING!

The catchword "WARNING" used in conjunction with the general caution symbol designates safety and danger notes in this installation manual that, if neglected, may cause **injury to persons**.



DANGER!

The catchword "DANGER" used in conjunction with the general caution symbol designates safety and danger notes in this installation manual that, if neglected, may lead to **severe injury or even death of persons**.

Safekeeping

Please safeguard this installation manual in a safe place, where it can be immediately accessed. If the equipment changes hands, the documentation must be passed on to the new operator.

If the documentation gets mislaid, please contact your Condair representative.

Language versions

This installation manual is available in various languages. Please contact your Condair representative for information.

2 For your safety

General

Every person working with the Condair ME Control must have read and understood the installation manual and the operation manual of the Condair ME Control before carrying out any work.

Knowing and understanding the contents of the installation manual and the operation manual is a basic requirement for protecting the personnel against any kind of danger, to prevent faulty operation, and to operate the unit safely and correctly.

All ideograms, signs and markings applied to the unit must be observed and kept in readable state.

Qualification of personnel

All work described in this installation manual **may only be carried out by specialists who are well trained and adequately qualified and are authorized by the customer.**

For safety and warranty reasons any action beyond the scope of this manual must only be carried out by personnel with appropriate industry recognised qualifications or training.

It is assumed that all persons working with the Condair ME Control are familiar and comply with the appropriate local regulations on work safety and the prevention of accidents.

Intended use

The Condair ME Control is intended exclusively for **air humidification and air cooling in AHU's or air ducts** within the specified operating conditions (see operation manual Condair ME Control). Any other type of application, without the written consent of the manufacturer, is considered as not conforming with the intended purpose and may lead to the Condair ME Control becoming dangerous.

Operation of the equipment in the intended manner requires **that all the information contained in this installation manual are observed (in particular the safety instructions).**

Danger that may arise from the Condair ME Control



DANGER!
Risk of electric shock!

The Condair ME control unit (and the optional submerged UV system) contain live mains voltage. Live parts may be exposed when the control unit (or the terminal box of the optional submerged UV system) is open. Touching live parts may cause severe injury or danger to life.

Prevention: The control unit must be connected to the mains only after all mounting and installation work has been completed, all installations have been checked for correct workmanship and the covers has been relocated properly.



WARNING!

Some type of evaporative material is manufactured from glass fibre. Though this material is not classified as hazardous, it is recommended that Personal Protection Equipment such as gloves, protective clothing and eye protection are used during handling to protect the user from fibres or dust. If dust is generated during handling it is recommended that respiratory protection is worn.

Correct lifting and handling

Lifting or handling of components always carries an element of risk, and therefore must only be carried out by trained and qualified personnel. Ensure that any lifting operations have been fully planned and risk assessed. All equipment should be checked by a skilled and competent health & safety representative.

It is the customer's responsibility to ensure that operators are trained in handling heavy goods and to enforce the relevant lifting regulations.

Preventing unsafe operation

All persons working with the Condair ME Control are obliged to report any alterations to the unit that may affect safety to the owner without delay and to **secure such systems against accidental power-up**.

Prohibited modifications to the unit

No modifications must be undertaken on the Condair ME Control without the express written consent of the manufacturer.

For the replacement of defective components use exclusively **original accessories and spare parts** available from your Condair representative.

3 Important notes

3.1 Inspection of the delivery

After receiving:

- Inspect shipping boxes for damage.
Any damages to the shipping boxes must be reported to the shipping company.
- Check packing slip to ensure all parts has been delivered.
All material shortages are to be reported to your Condair representative within 48 hours after receipt of the goods. Condair assumes no responsibility for any material shortages beyond this period.
- Unpack the parts/components and check for any damage.
It is particularly important that the tank, structural components, and fixings (such as studs) are inspected as damage to these items could affect the structural integrity of the system. If parts/components are damaged, notify the shipping company immediately.
- Check whether the components are suitable for installation on your site according to the product specification (refer to model key in the operation manual).

3.2 Storing/Transportation/Packaging

Storing

Until installation store the system components in its original packaging in a protected area meeting the following requirements:

- Room temperature: 1 ... 40 °C
- Room humidity: 10 ... 75 %rh

Transportation

For optimum protection of the product, always transport the unit in its original packaging. The packaged Condair ME unit is able to be transported by trained personnel, using an appropriate lifting/transporting device from the underside.



The evaporative module **must not** be transported with the optional droplet separators fitted.



It is the customer's responsibility to ensure that operators are trained in handling heavy goods and that the operators comply with the appropriate regulations on work safety and the prevention of accidents.

Packaging

Keep the original packaging of the components for later use.

In case you wish to dispose of the packaging, observe the local regulations on waste disposal. Please recycle packaging where possible.

3.3 Product designation / Which model do you have

The product designation and the most important unit data are found on the rating plate fixed to the evaporative module and the control unit.

Information regarding the rating plate and the product key can be found in the operation manual of the Condair ME Control.

3.4 UL approved installation

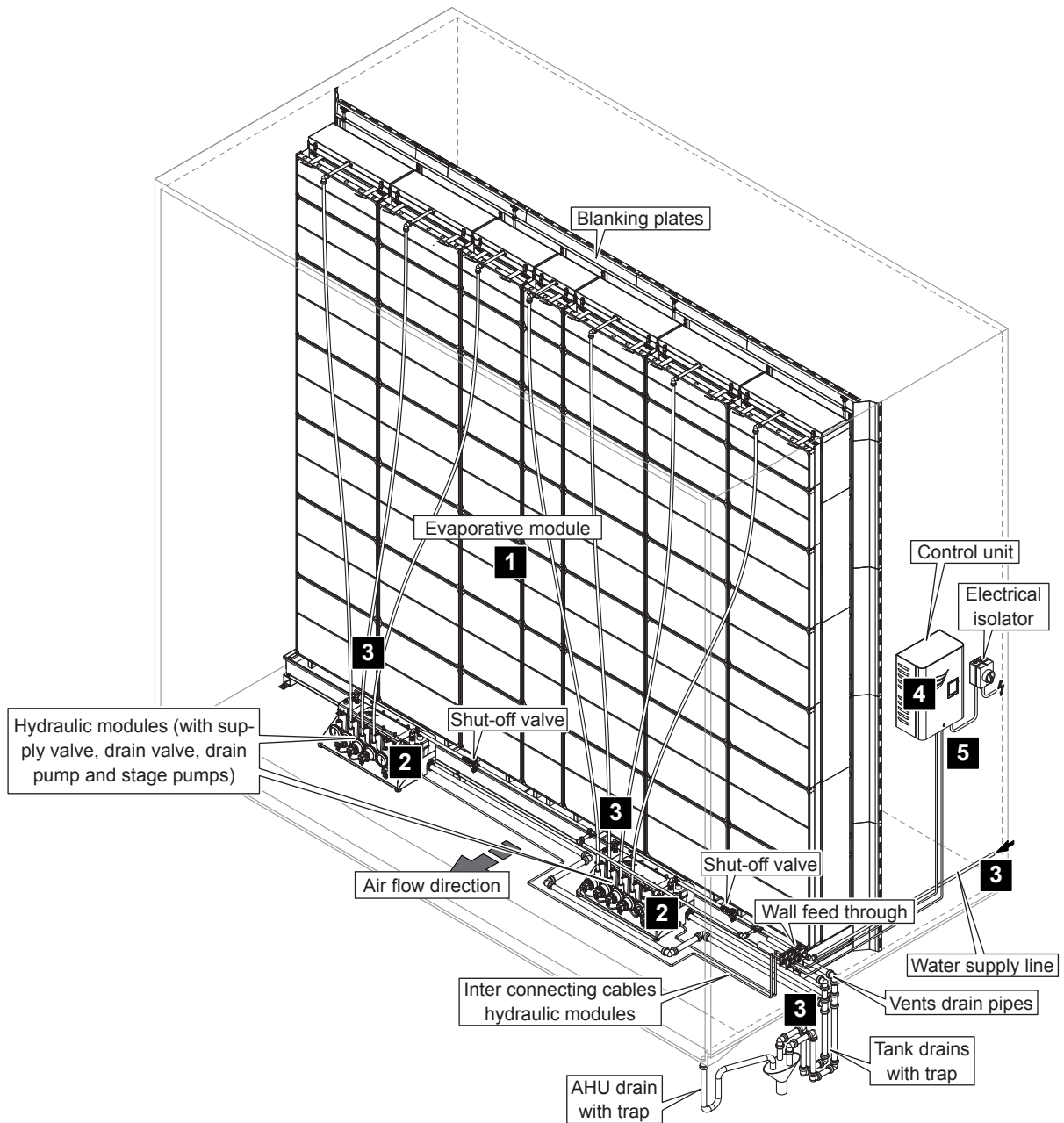
In order to maintain a UL approved installation, the following installation requirements must be met, otherwise the Condair ME system will not be approved under UL 998.

1. The Condair ME Control hydraulic modules must be installed external to the air stream in accordance with the typical installation drawing in [chapter 4.1.2](#).
2. All interconnecting piping and connections between the evaporative module and the hydraulic module, in direct contact with the air stream must be either copper, stainless steel or brass.
Note: water quality should be considered when selecting an appropriate material (i.e. copper is not suitable for RO water).
3. The Condair ME Control unit contains a large reservoir of water when in operation. Install the ME unit where there is no risk of water damage, otherwise make provisions to contain any leakage.
4. The Condair ME Control evaporative module must have either fibre or cooling media types installed. UL 998 is not valid if the Condair ME Control evaporative module has polyester media installed.

4 Installation

4.1 Installation overviews

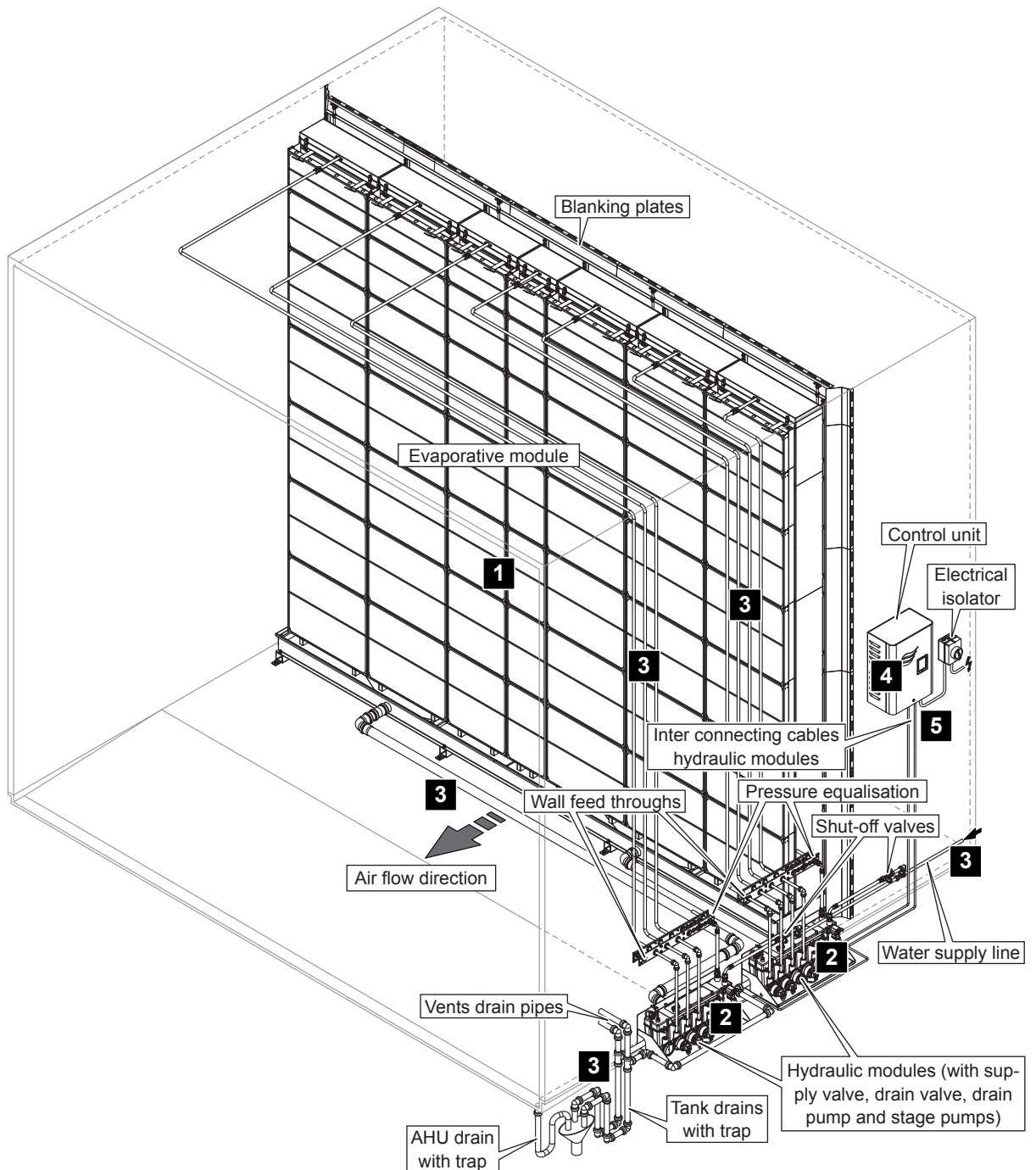
4.1.1 Typical installation Condair ME Control (internal installation)



- 1 - Mounting the evaporative module --> see [chapter 4.2](#)
- 2 - Mounting the hydraulic modules --> see [chapter 4.3](#)
- 3 - Water installation --> see [chapter 4.5](#)
- 4 - Mounting the control unit --> see [chapter 4.5.4](#)
- 5 - Electrical installation --> see [chapter 4.6](#)

Fig. 1: Typical installation Condair ME Control (internal installation)

4.1.2 Typical installation Condair ME Control (external installation)



- 1 - Mounting the evaporative module --> see [chapter 4.2](#)
- 2 - Mounting the hydraulic modules --> see [chapter 4.3](#)
- 3 - Water installation --> see [chapter 4.5](#)
- 4 - Mounting the control unit --> see [chapter 4.5.4](#)
- 5 - Electrical installation --> see [chapter 4.6](#)

Fig. 2: Typical installation Condair ME Control (external installation)

4.2 Mounting the evaporative module

4.2.1 Notes on positioning the evaporative module

The design and dimensioning of the AHU/air duct as well as the location of the evaporative module inside the duct are determined, recorded and set compulsory when planning the entire system. Prior to installation, however, make sure the following criteria have been taken into consideration:

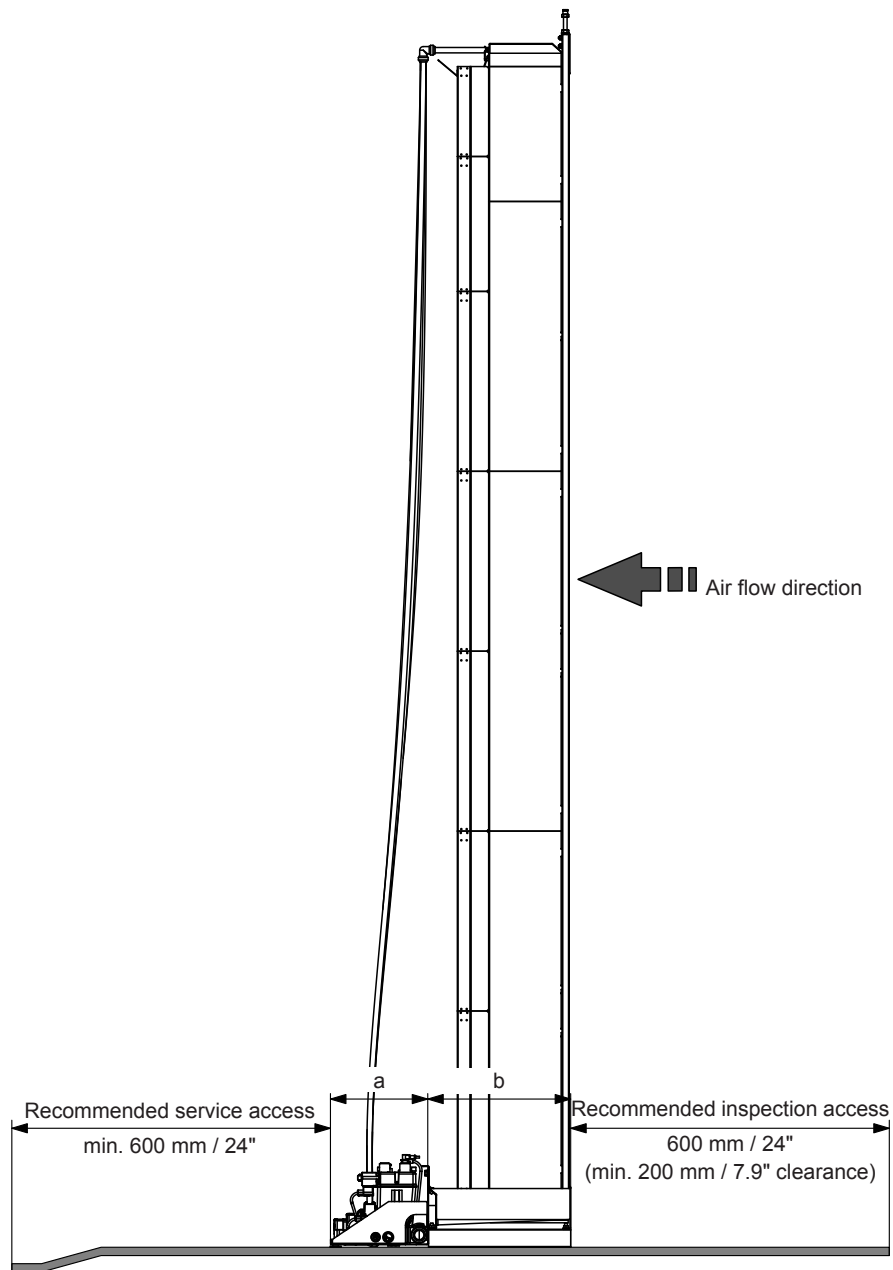
- The AHU/air duct floor must be designed with a loading capacity capable of supporting the evaporative module's weight.
- In the area where the evaporative module is installed the floor of the AHU/air duct must offer a plane support (lengthwise and crosswise).
- The evaporative module must be installed in a **waterproof** section of the AHU/air duct.
- Downstream, directly after the evaporative module a **drain pan with provision for running water to waste** must be installed. The drain must be connected via a drain trap to the waste water line of the building. The drain trap must be sufficiently high and must be filled with water prior to commissioning, so that the drain trap is not emptied by the air pressure in the duct. The drain pan and the drain trap must be accessible for cleaning and disinfection as part of the periodic maintenance of the system.
- For installation and maintenance sufficiently large access doors before and after the evaporative module must be available in the AHU/air duct.
- The supply air must be filtered. We recommend to install an **air filter with quality standard F7 (EU7)** or better before the evaporative module. If no air filter or an air filter with lower quality is installed an increased maintenance will result.
- An **even air flow over the full cross section** of the evaporative module must be guaranteed. If necessary, rectifiers or perforated plates must be installed.
- The evaporative module must be positioned on upstands (supplied) to allow to install the drain pipe with a downslope through the side wall of the AHU/air duct.
- In case of low ambient temperature the AHU/air duct must be insulated to prevent the moist air from condensing inside the duct.
- If the AHU is equipped with a heater, make sure it is at least 600 mm (24") away from the evaporative module.
- If the evaporative module includes the optional droplet separator cassettes for high air velocities, then the droplet separator cassettes must be installed.
- Appropriate clearance must be available for the hydraulic modules (and associated plumbing) when installing externally.
- For commissioning and maintenance we recommend a **minimum** of 600 mm (24") of free space after the evaporative module.



WARNING!

Consideration should be given to the amount of space required after the evaporative module for access equipment, particularly for taller systems as personnel will require safe access to the top of the evaporative module.

- For inspection we recommend 600 mm (24") of free space before the evaporative module. If inspection access is not required before the module, a minimum clearance of 200 mm (7.9") is acceptable provided any heater is at least 600 mm (24") away from the evaporative module.



Dimension "a":	
ME Control (internal mounting):	272 mm / 10.7"
ME Control (external mounting):	111 mm / 4.4"
Dimension "b":	
F-Type fibre cassettes F75/F85/F95:	395 mm / 15.6"
C-Type fibre cassettes C85/C95:	525 mm / 20.7"

Fig. 3: Positioning of the evaporative module (centre drain tank)



CAUTION!

The ME evaporative module contains a large reservoir of water when in operation. Install the ME unit where is no risk of water damage, otherwise make provisions to contain any leakage.

4.2.2 Installation procedure evaporative module



A full risk assessment must be completed by suitably trained personnel prior to installing the ME unit. There may be increased risk when installing systems that necessitate working at height.

The following risks should be considered (this list is not exhaustive, and there may be additional site specific risks that will need to be considered):

- Electrical work
- Manual handling
- Musculoskeletal disorders
- Working at height
- Falling objects & objects dropped from higher levels
- Risks arising from the use of Mobile Elevated Work Platforms
- Risk of contact with ceilings, overhead items or asbestos roofing while using access equipment
- Adverse weather conditions
- Unsuitable surface and ground
- Other equipment, machinery or supply pipework in the vicinity of the work area

Installation of the ME unit must only be carried out by trained personnel, and all installation equipment must be checked by a skilled and competent health & safety representative.

1. Mounting the tank upstands to the tank:

- Mounting the **tank upstands supplied by Condair**: fix tank upstands to the tank as shown in the figure below using the nuts (M8, AF: 13 mm) and washers supplied.

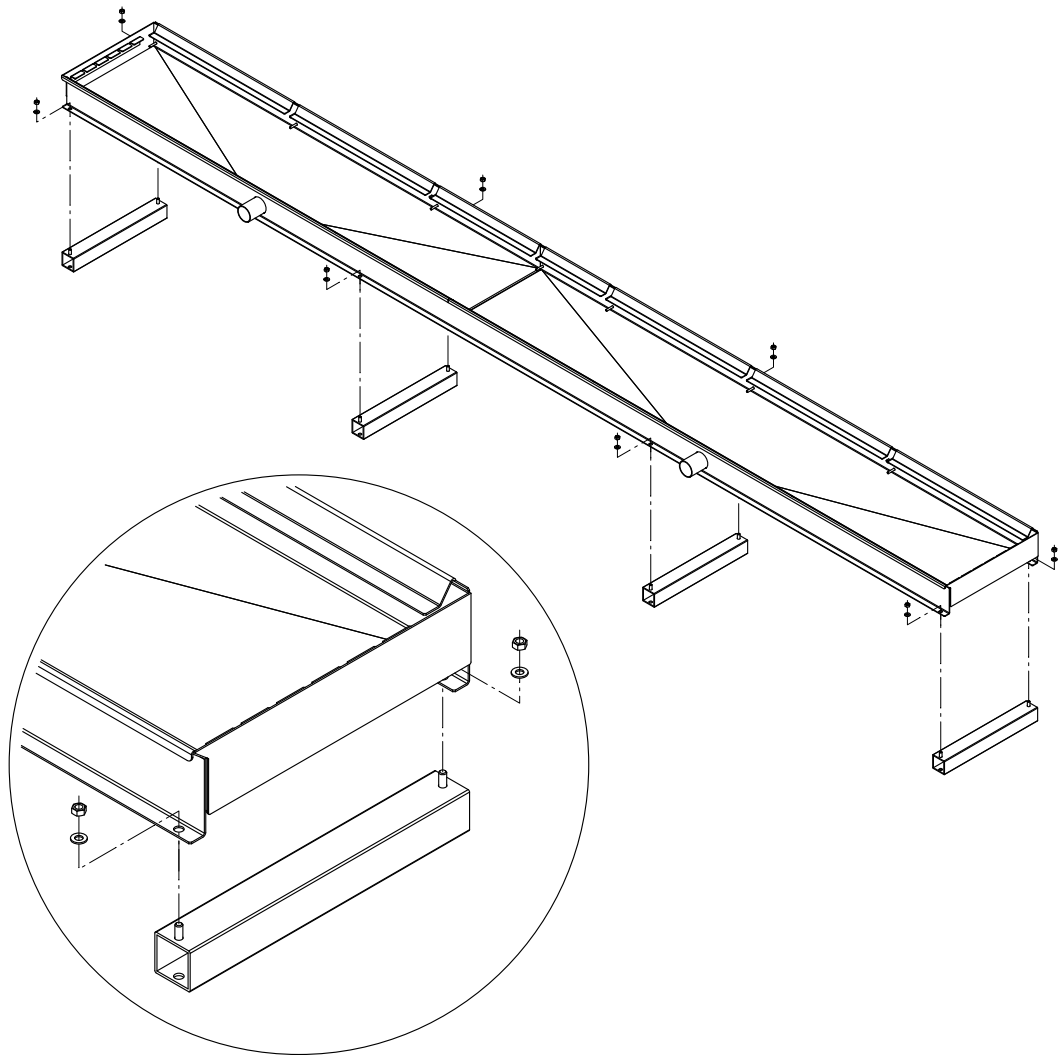


Fig. 4: Mounting the tank upstands to the tank

2. Mounting the tank:

- Insert the tank into the AHU/air duct.



WARNING!

Use an appropriate lifting device or handle the tank with the help of another person to position it inside the duct. It is the customer's responsibility to ensure that operators are trained in handling heavy goods and to enforce the relevant lifting regulations.

- Align the tank to the centre of the duct and perpendicular to the duct walls. When aligned fix tank upstands to the duct floor.



CAUTION!

The installer must take appropriate measures to ensure that the duct floor remains water proof once the tank upstands has been fixed to the duct floor.

- Check that the tank is lengthwise and crosswise exactly horizontal using a level.

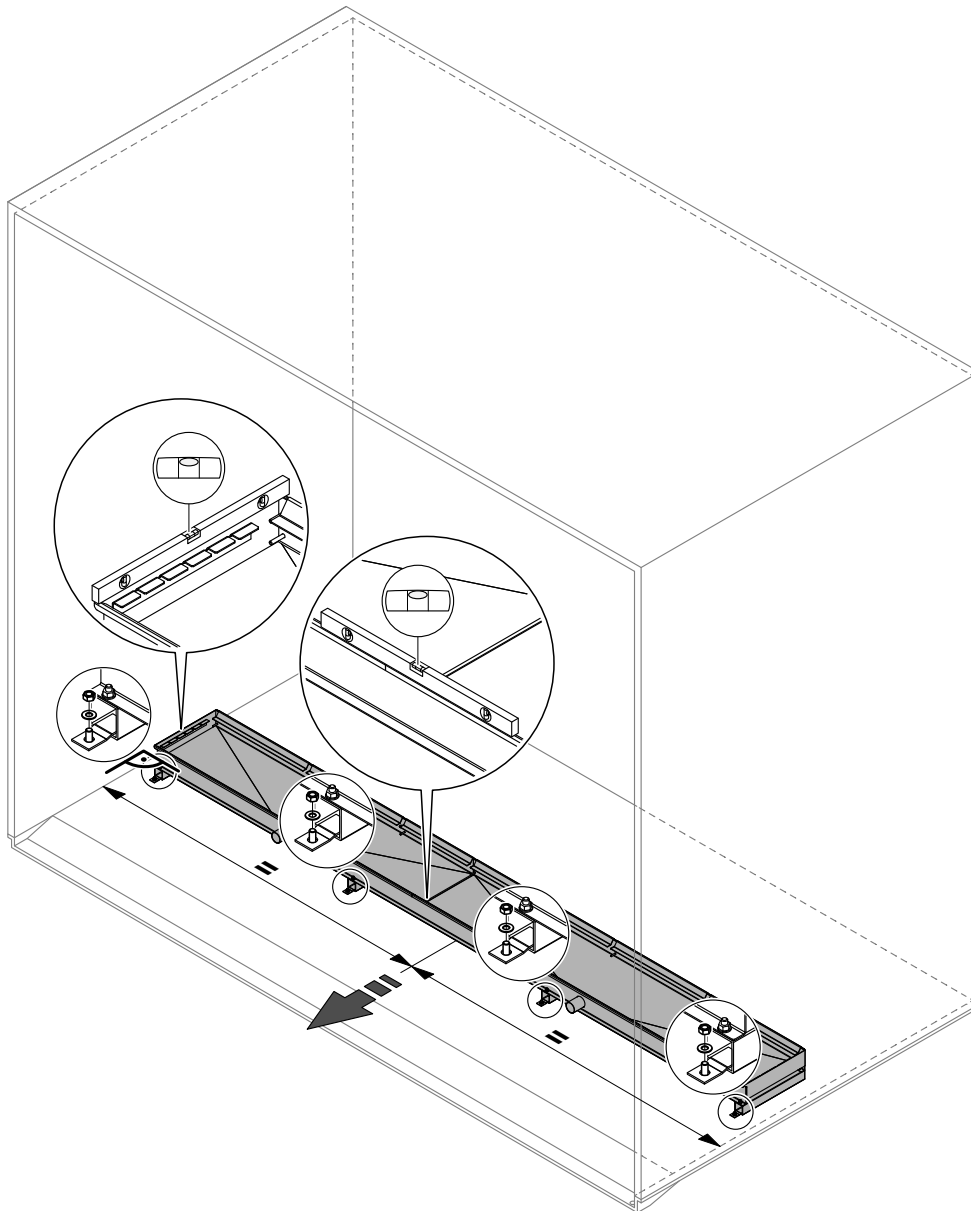


Fig. 5: Mounting the tank

3. Fix frame to the tank:

- Fix the vertical supports to the tank using the nyloc nuts (M6, AF: 10 mm) and M6 washers. Then, align the vertical supports exactly vertical using a level and tighten the nuts.
- Fix the cross member to the vertical supports using the nyloc nuts (M6, AF: 10 mm) and M6 washers. Then, tighten the nuts.

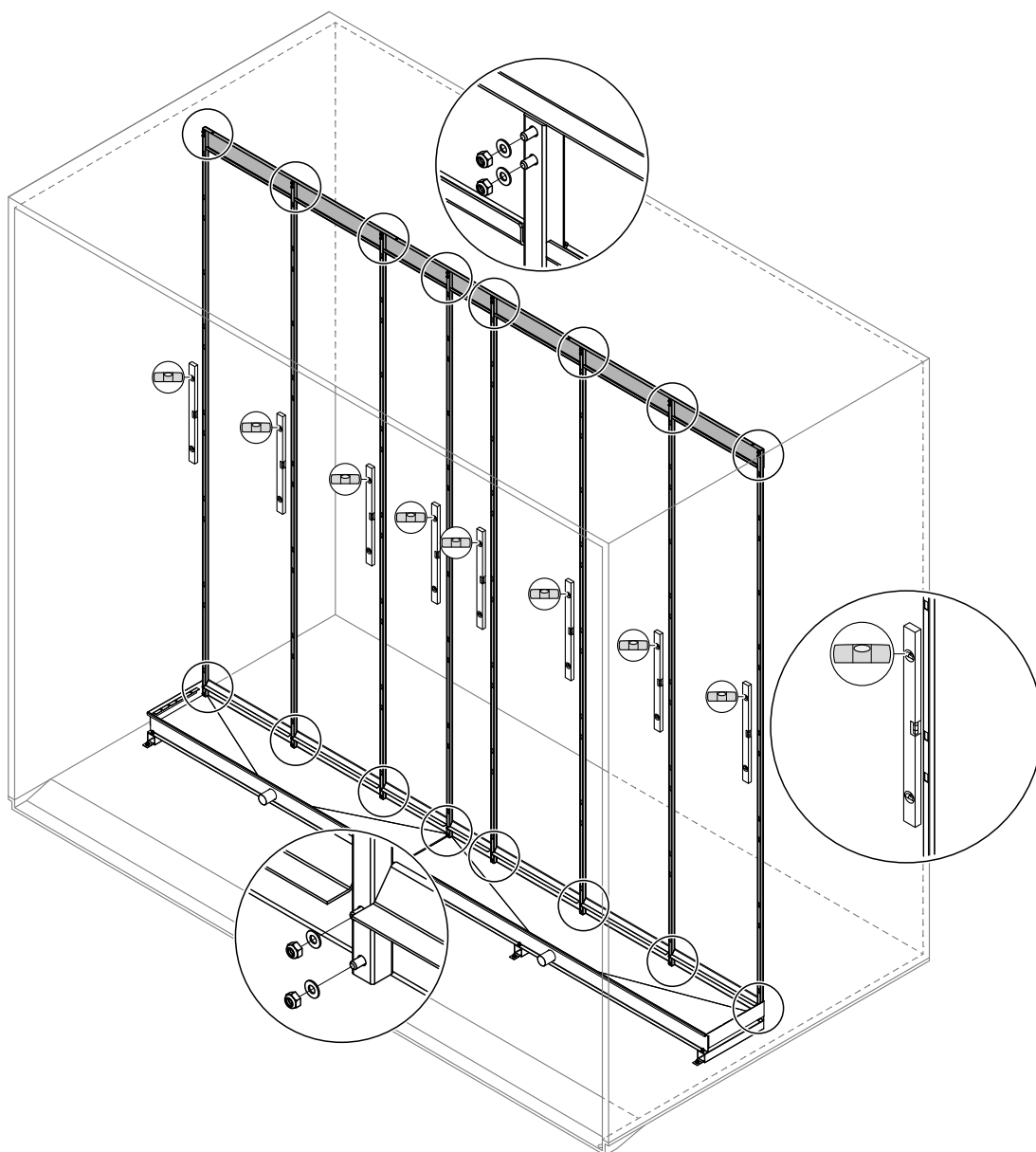


Fig. 6: Fix frame to tank

4. Fix cross member of frame to AHU/duct ceiling:

- Fix the cross member to the AHU/duct ceiling using appropriate fixings (supplied as part of the installation kit). Before tightening the screws (not supplied) align the vertical supports exactly vertical using a level.



WARNING!

If the cross member is not secured to the AHU/duct ceiling there is a risk that the evaporative module could fall over, potentially causing injury or damage.

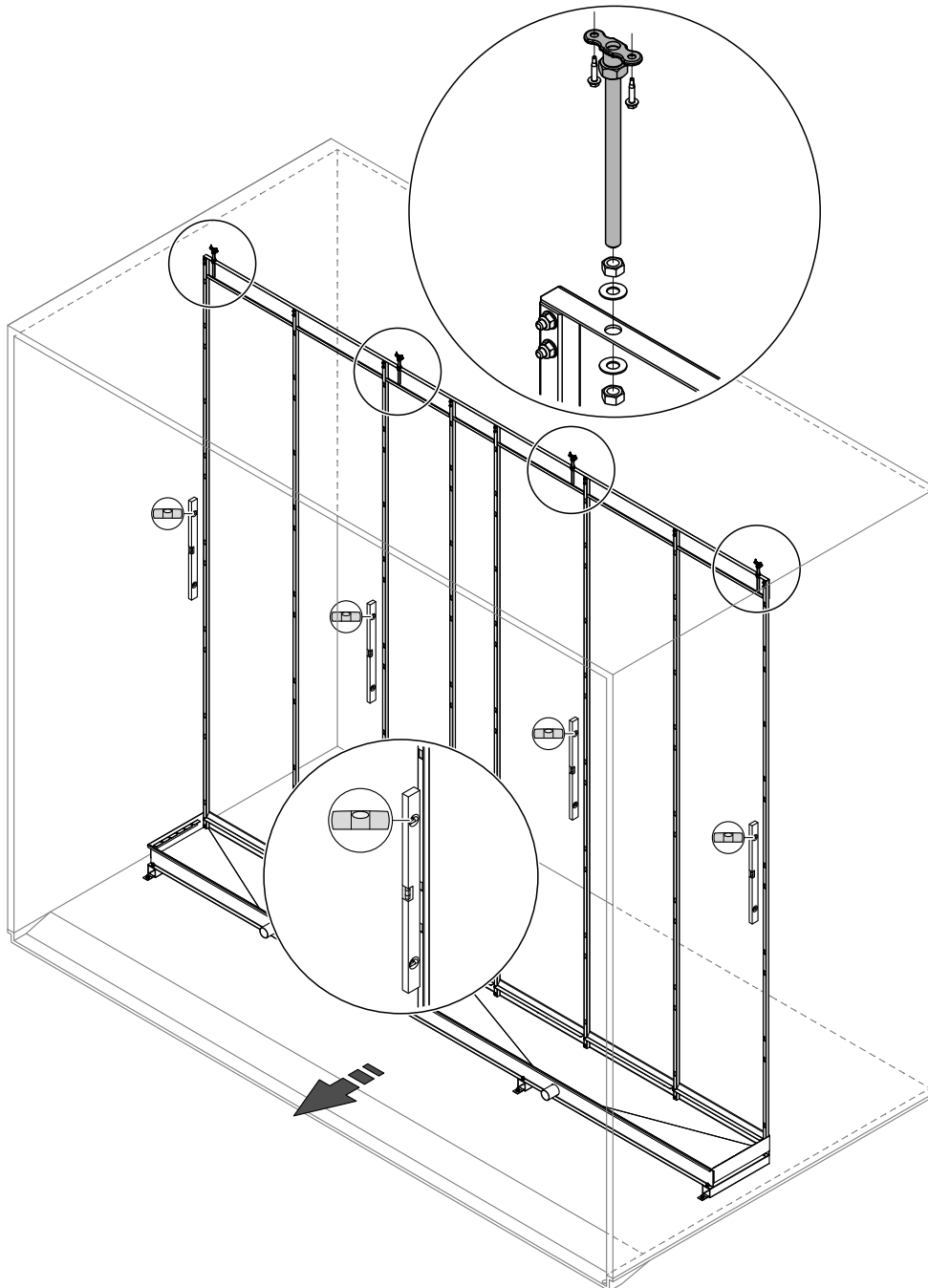


Fig. 7: Fix cross member to AHU/duct ceiling

5. Mount the blanking plates on the air inlet side (blanking plates available as option):

- Starting on each duct side at the bottom fix the side blanking plates to the duct wall using appropriate fixings. Before fixing make sure the side blanking plates are aligned exactly vertical and the free end of the blanking plates touches the side of the corresponding vertical support.
- Starting on one side fix the upper blanking plates to the duct ceiling using appropriate fixings. Before fixing make sure the upper blanking plates are aligned exactly perpendicular to the duct walls and the free ends of the blanking plates touch the cross member of the frame. Also ensure the ends of the blanking plates are touching the side blanking plates.
- Starting on one side fix the lower blanking plates to the duct floor using appropriate fixings. Before fixing make sure the lower blanking plates are aligned exactly perpendicular to the duct walls and the free ends of the blanking plates touch the tank wall. Also ensure the ends of the lower blanking plates are touching the side blanking plates.



CAUTION!

The installer must take appropriate measures to ensure that the duct floor remains water proof once the lower blanking plates have been fixed to the duct floor.

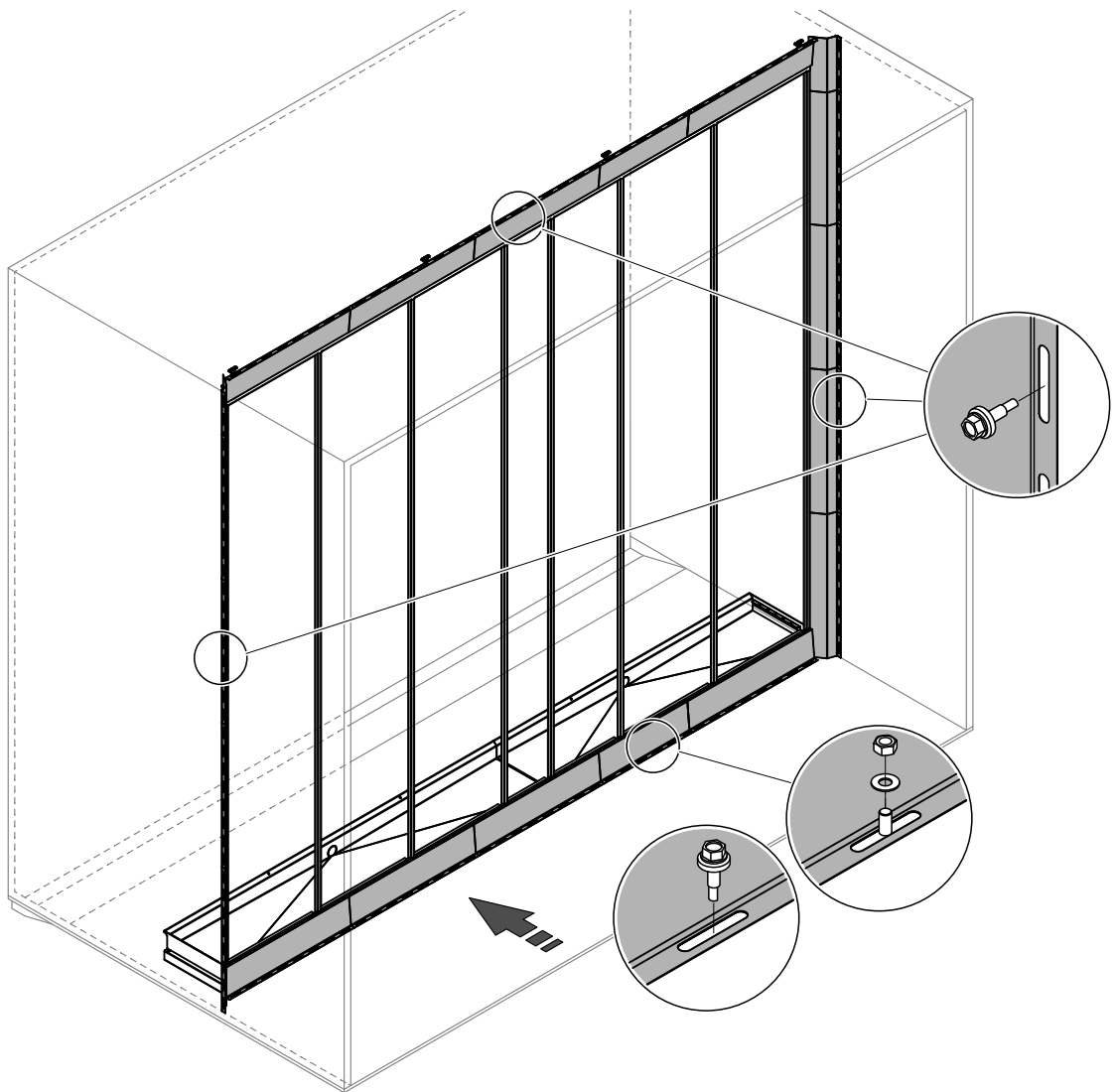


Fig. 8: Mounting the optional Nordmann blanking plates on the air inlet side

6. Mounting the crossbar:

- Fix the supplied crossbar support(s) to the tank using the M6 cross-head bolt and the two stop nuts (M8, AF: 13 mm) according to the figure below.

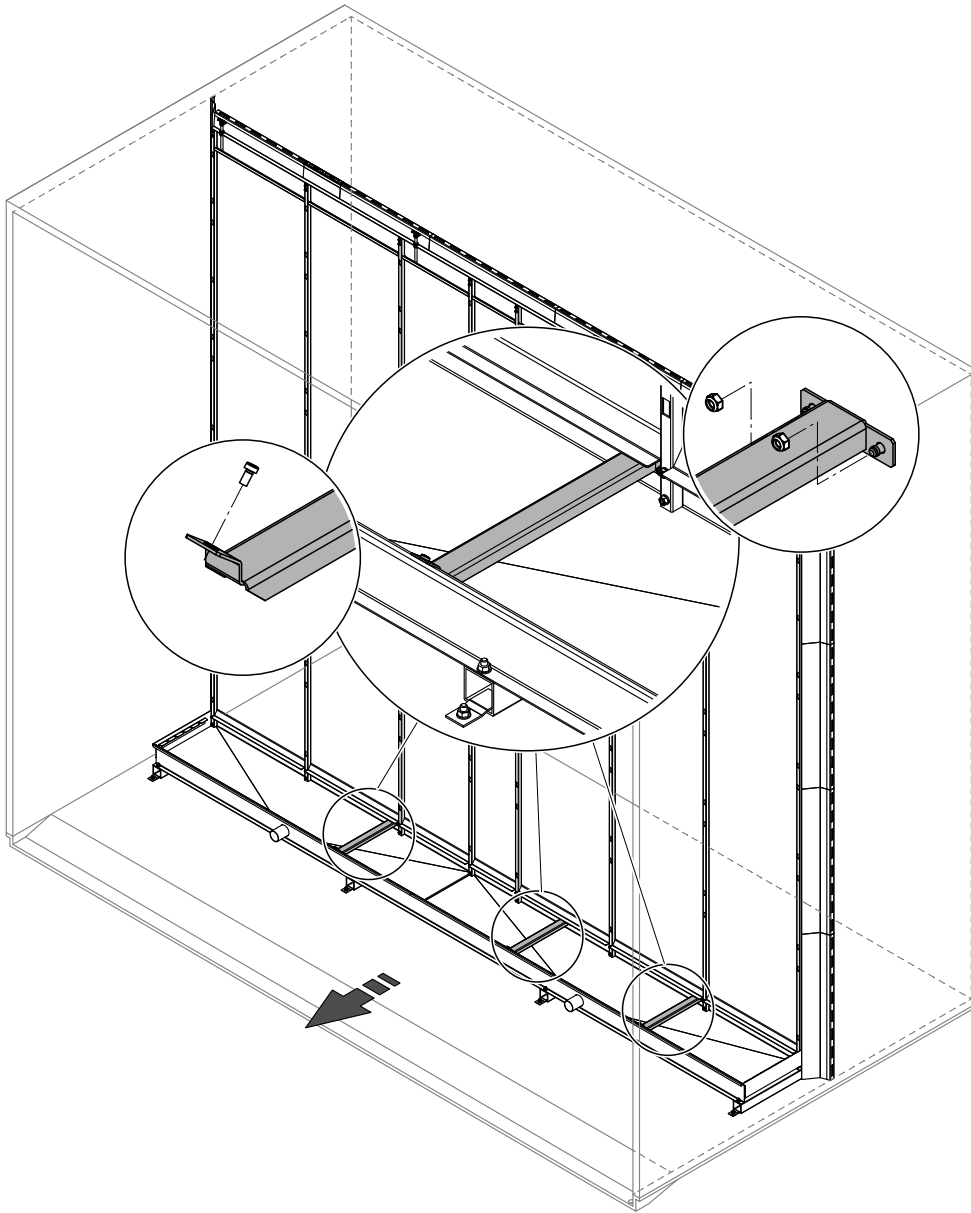


Fig. 9: Mounting the crossbar support(s)

- Put the cross bar on the corresponding cross bar bracket with a distance of "A" to the vertical support (see table below). The cross bar should be positioned so that the evaporative cassettes sit on the edge of the cross bar, and the slots in the side of the cross bar should face the air-off side of the evaporative module as shown below.

Type evaporative cassette (according to rating plate)	Dimension A (nominal)
F75	100 mm (4")
F85	150 mm (6")
F95	200 mm (8")
C85	200 mm (8")
C95	300 mm (12")

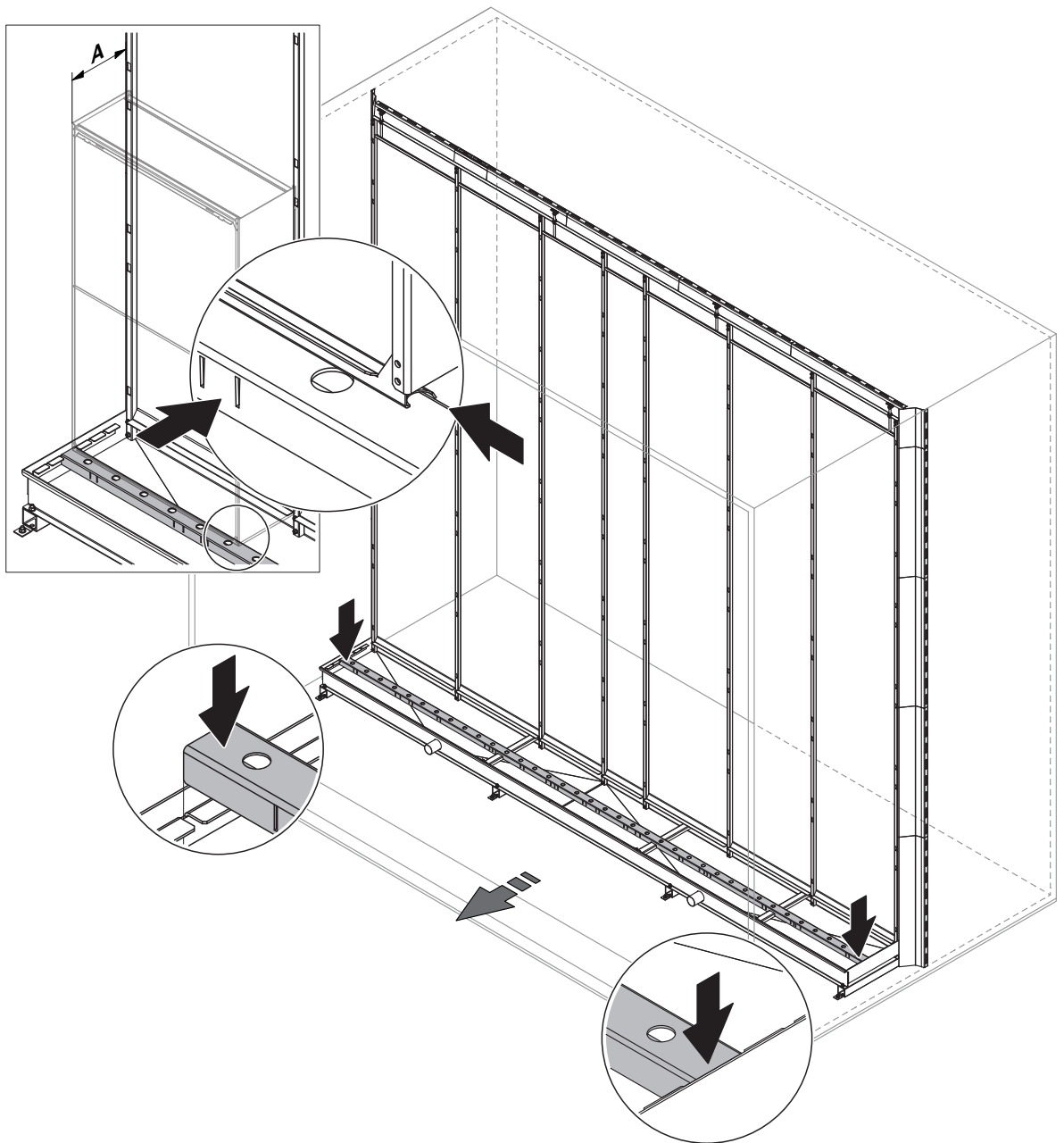


Fig. 10: Mounting the cross bar

7. Mount optional submerged UV, if applicable:

If your system is equipped with the submerged UV mount UV bulb assembly to the cross bar and the junction box to the tank in accordance with the separate manual for this option.

8. Mount distribution head assembly to the topmost evaporative cassettes:

Note: The topmost evaporative cassettes will be the ones that are shortest (vertically)

- Mount the appropriate distribution cassettes onto the corresponding evaporative cassettes, by hooking the return on the underside of the distribution cassette under the top strut of the evaporative cassette.
- Mount the appropriate distribution heads onto the corresponding evaporative cassettes or distribution cassettes respectively, by hooking the return on the underside of the distribution head under the top strut of the cassette below. Then secure the distribution heads to the evaporative cassettes using the locking clamps on the distribution heads.

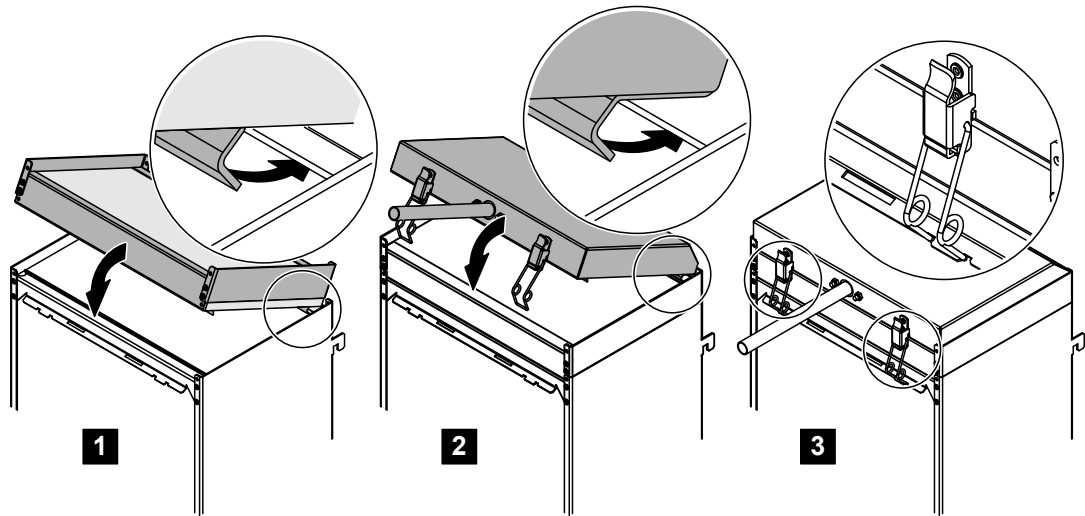


Fig. 11: Mounting the distribution head assembly onto glass fibre evaporative cassettes

9. Mount evaporative cassettes:

Note: to avoid damage to the evaporative cassettes during transit, we recommend that the evaporative cassettes are fitted on site.

- Before installing the evaporative cassettes sweep the interior of the tank.
- Starting with the tallest evaporative cassettes on the bottom and working up to the shortest evaporative cassette on the top, hook the cassettes into the vertical supports. Make sure the overlying cassettes slip properly into each other.

Note: The narrowest evaporative cassettes should be positioned near the center of the tank, and the widest evaporative cassettes should be positioned at the right and left ends of the tank (see [Fig. 13](#)).

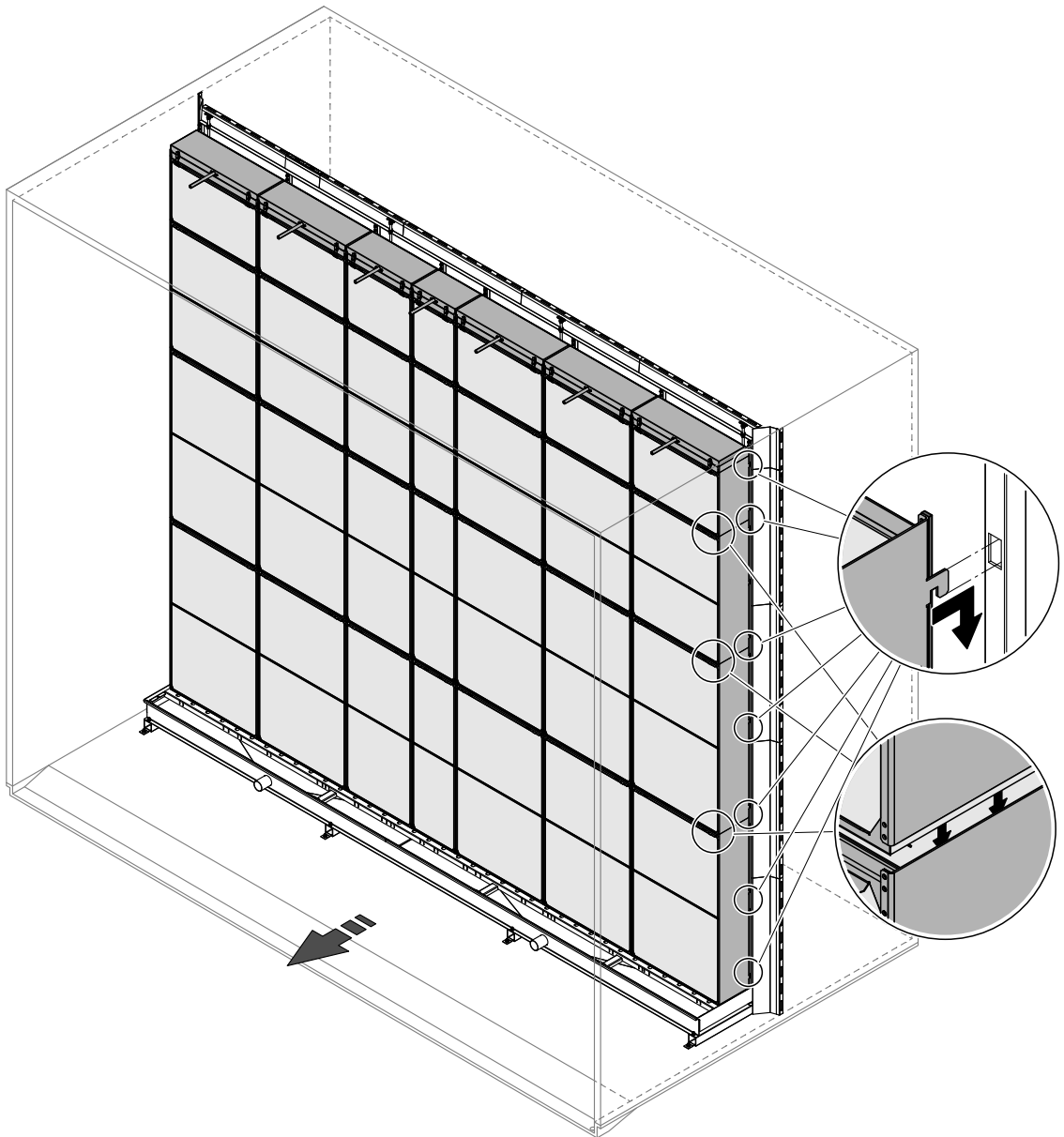


Fig. 12: Mount evaporative cassettes

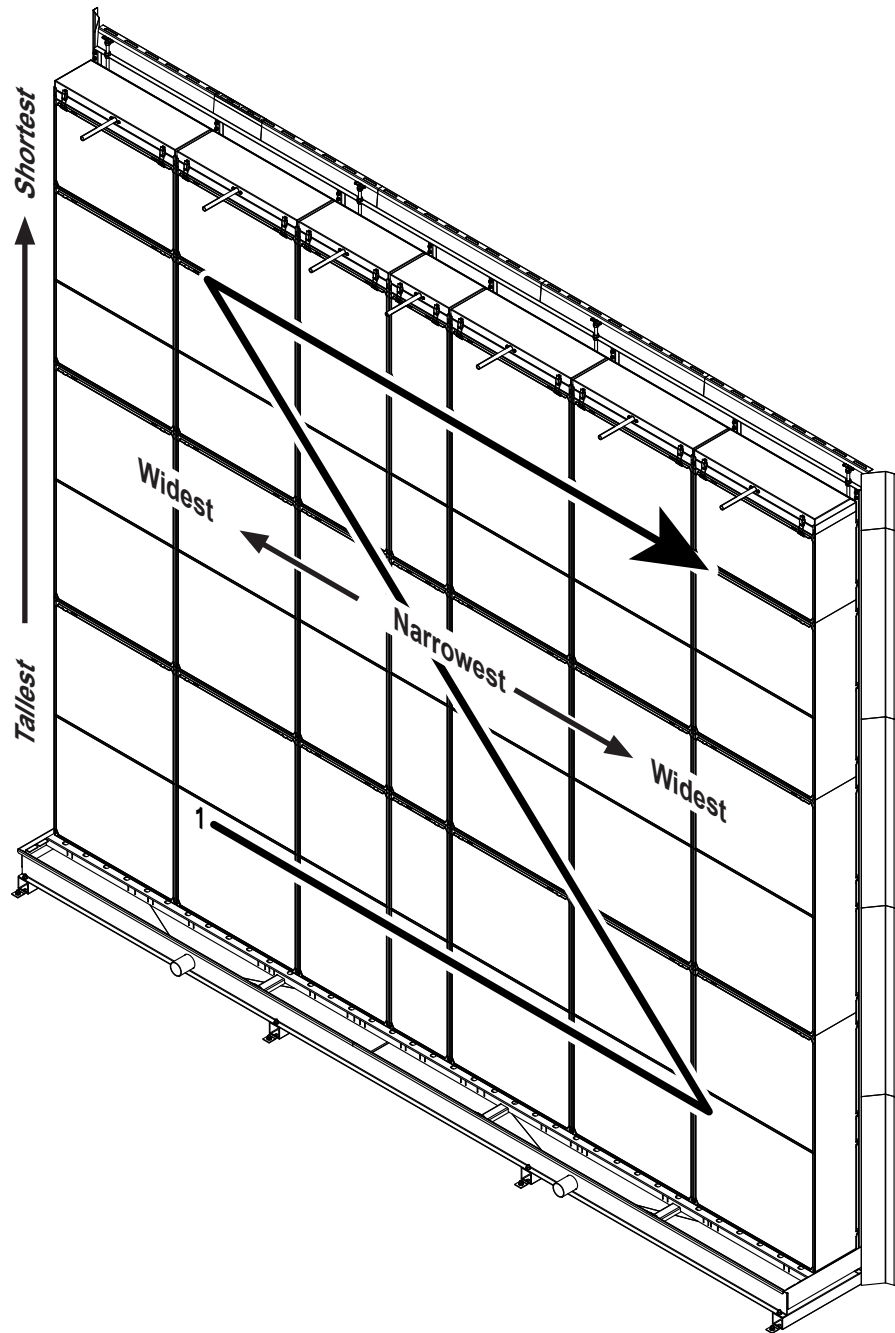


Fig. 13: Mounting order and positioning of the evaporative cassettes

10. Mount the droplet separator cassettes (this step must only be carried out, if your system is equipped with a droplet separator):

Note: To avoid damage to the droplet separator cassettes during transit, the droplet separator cassettes must be fitted on site.

10a. Fit the droplet separator brackets to the top of each bank of evaporative cassettes:

- Release the locking clamps holding each distribution head assembly in place.
- Lift the distribution head and distribution cassette slightly and insert the hem-folded end of the two separator brackets into the recess in the top strut of the uppermost evaporative cassette, position each bracket above the slots in the cassette strut.
- Reseat the distribution cassette and distribution head to grip the separator brackets in place and secure them using the distribution assembly locking clamps.

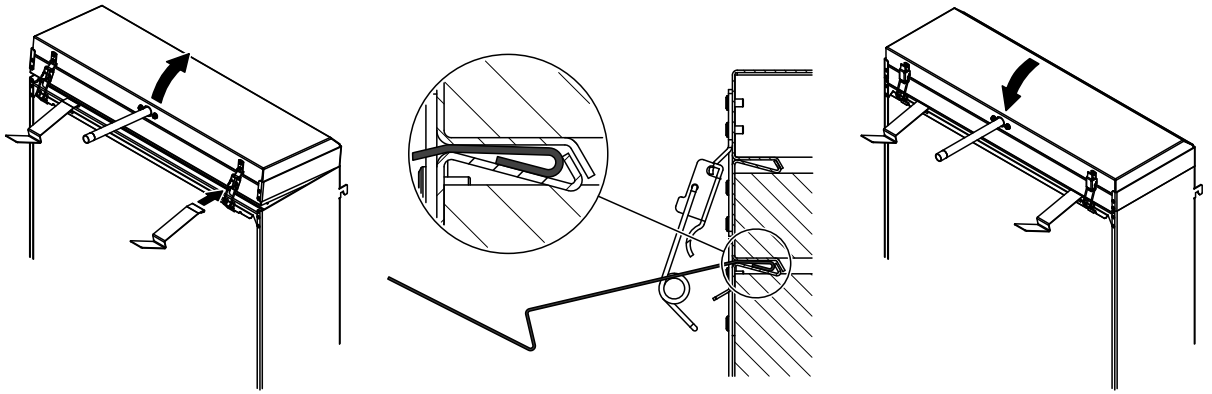


Fig. 14: Mounting the droplet separator brackets

10b. Assemble the separator cassette banks:

- Starting with the tallest droplet separator cassettes on the bottom, and working towards the shortest cassettes at the top, rivet the banks of the droplet separator cassettes together using a rivet gun with \varnothing 3.2 mm (0.13") blind rivets. Make sure the overlying cassettes slip properly into the subjacent cassettes.

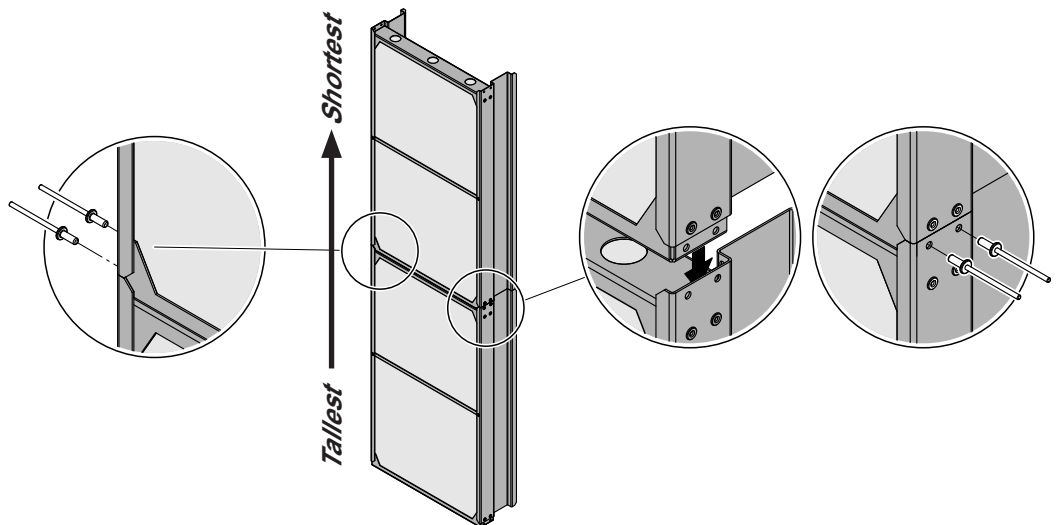


Fig. 15: Riveting the banks of the droplet separator cassettes together

10c. Mount the separator cassette banks:

- Hook the lower separator brackets into the cross bar.
- Then, starting on one side place one separator bank after the other onto the lower separator brackets, align with the evaporative cassette banks and ensure the framework of the droplet separators fit around the metal frames of the evaporative cassettes. Slide the top eliminator cassette under the separator brackets until they spring back down and secure the separator cassette bank firmly in place.

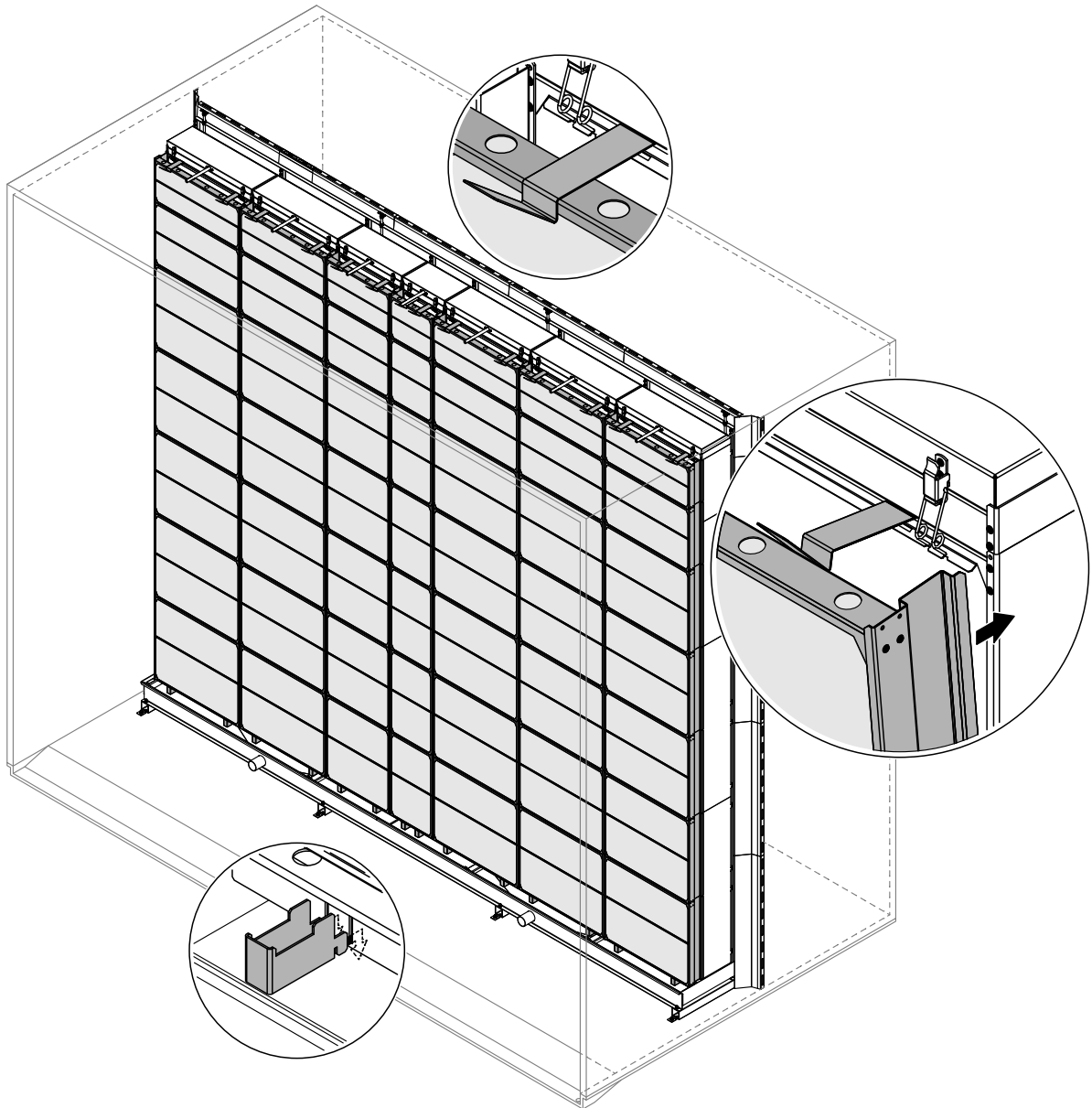


Fig. 16: Mounting the droplet separator banks

4.3 Mounting the hydraulic modules

The mounting procedure of the hydraulic modules depends on whether or not the hydraulic modules are mounted internal or external to the duct.

4.3.1 Mounting the hydraulic modules (internal installation)

1. Match the hydraulic units labelled "A" and "B" to the tank connectors labelled "A" and "B".
2. Apply **silicone free grease** (e.g. gasket grease) onto the surface of the tank connectors and onto the surface of the rubber sealing inside the connector of the hydraulic modules.
3. Then, slide the connector bore of the hydraulic module carefully onto the matching tank connector ("A" or "B") until it comes to a stop.
4. **With the help of a spirit level and the levelling feet on the bracket, align the hydraulic modules exactly horizontal in both planes, i.e. front to back and left to right.** Then, fix the hydraulic modules to the tank using the brackets, nuts (M8, AF: 13 mm) and washers supplied and tighten the nuts.

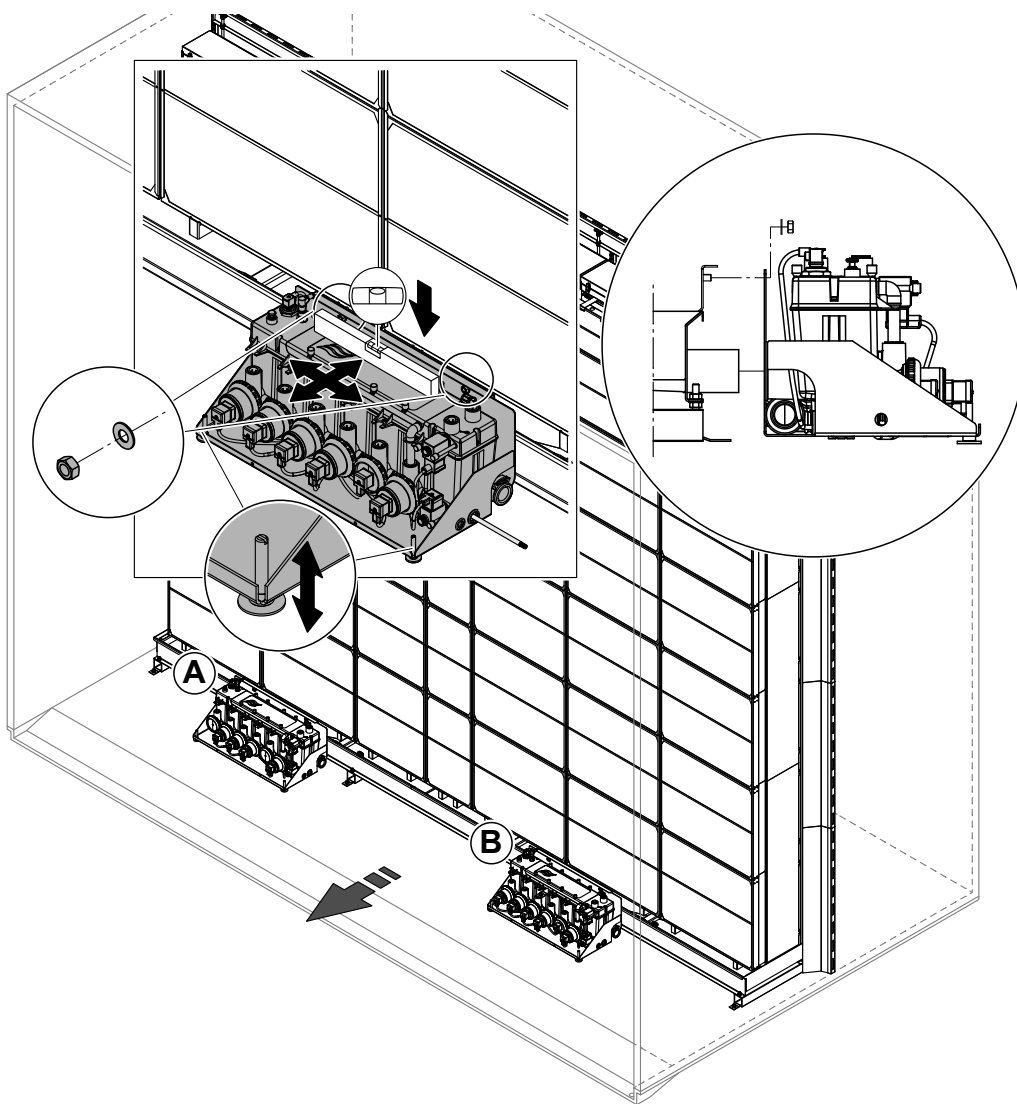


Fig. 17: Mounting the hydraulic modules (internal installation)

4.3.2 Mounting the hydraulic modules (external installation)

Clearances to be observed

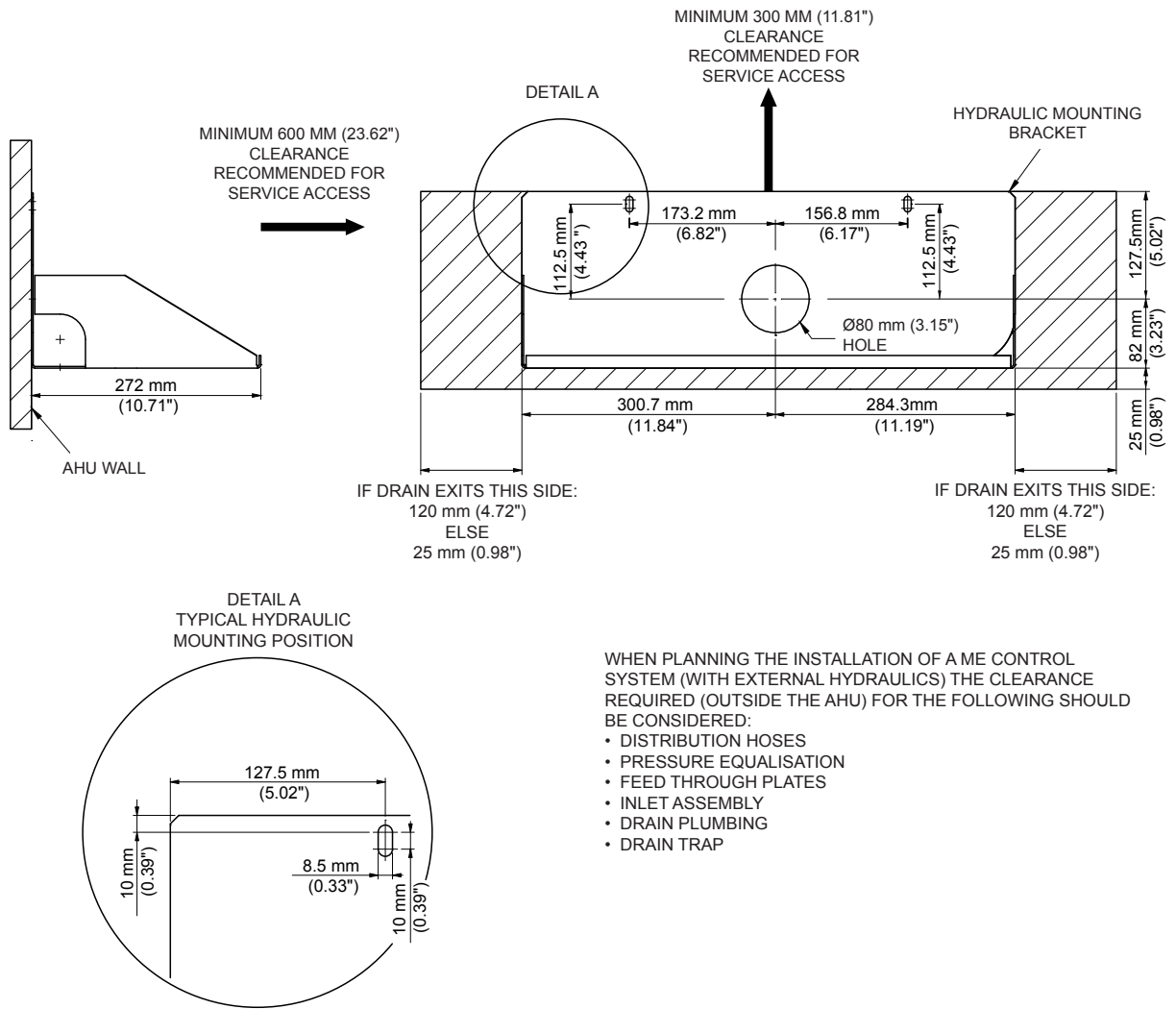


Fig. 18: Clearances to be observed when mounting the hydraulic modules externally

Note: Condaair ME Control humidifiers that are greater than 3000 mm / 118" wide will require two of the above hydraulic modules. Please ensure adequate space is available for both hydraulic modules.

Mounting procedure

1. Mark the positions of the holes for the drain pipe feed throughs on the AHU/duct wall.
Important: when mounted the drain pipe must have a **downslope of 1 to max. 2 % towards the AHU/duct wall.**
2. Drill $\varnothing 55$ mm (2.2") holes for the drain pipes into AHU/duct wall.
3. Lead drain pipes ($\varnothing 50$ mm or $\varnothing 54$ mm (2.125") as applicable) through the holes in the AHU/duct wall and connect them to the tank using the elbow unions (both supplied as part of an optional tank coupling kit).
4. Cut drain pipes to length.
Important: the ends of the drain pipes must protrude 46 mm (1.8") minimum to 70 mm (2.75") maximum from the AHU/duct wall. Otherwise correct mounting of hydraulic modules is not possible.
5. **Important: De-burr leading edge of drain pipes, to avoid damage to the rubber seal, or injury.**
6. Seal between the pipes and the holes in the AHU/duct wall using silicone-free sealant.
7. Match the hydraulic units labelled A & B to the drain pipes from the tank connectors labelled A & B.
8. Apply **silicone free grease** (e.g. gasket grease) onto the surface of the drain pipes and onto the surface of the rubber sealing inside the connector of the hydraulic modules.
9. Then, slide the connector bore of the each hydraulic module carefully onto the matching drain pipe (A or B) until it comes to a stop.
10. **With the help of a spirit level align hydraulic modules exactly horizontal.** Then, fix the hydraulic modules to the AHU/duct wall using appropriate fixings.

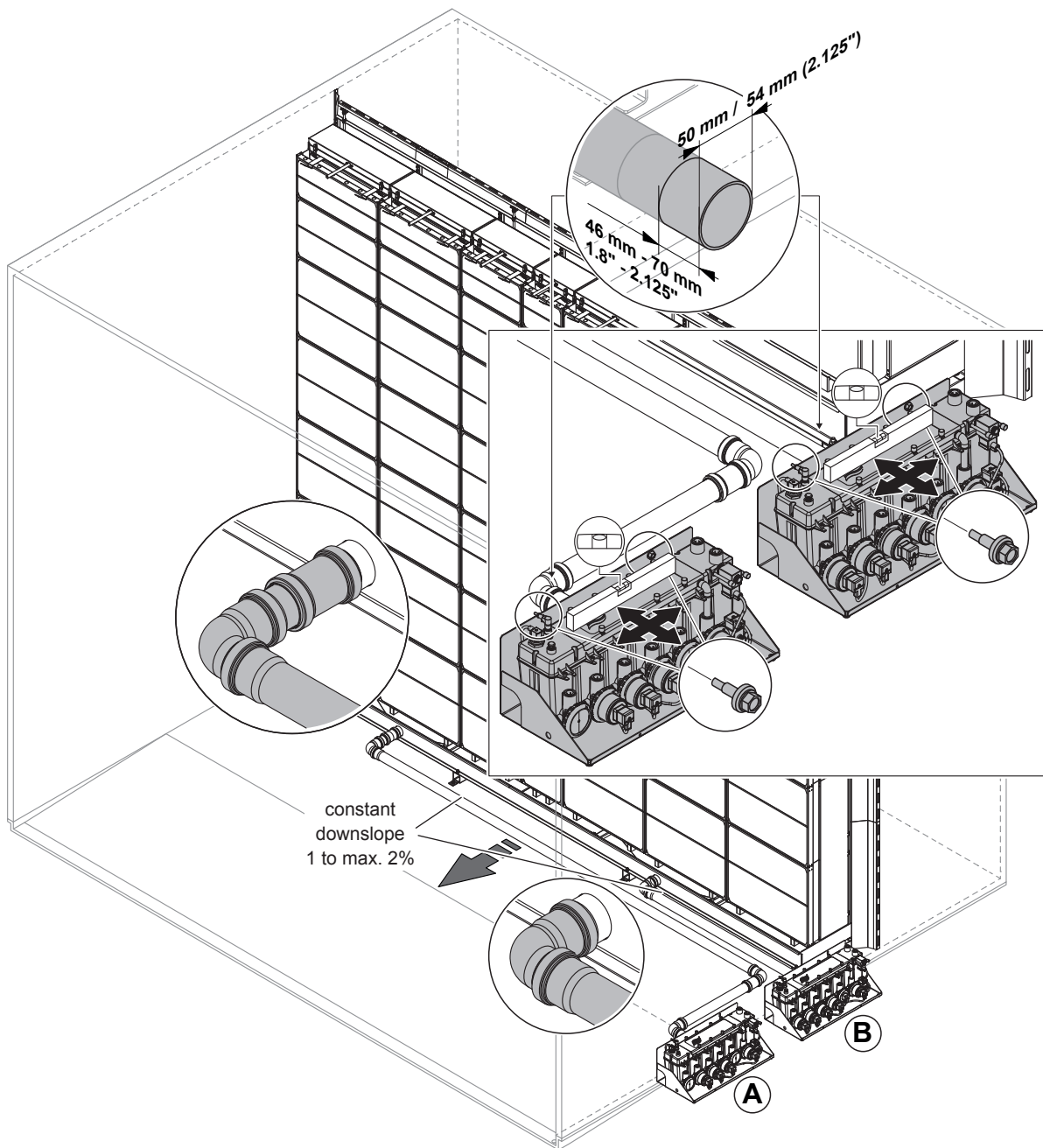
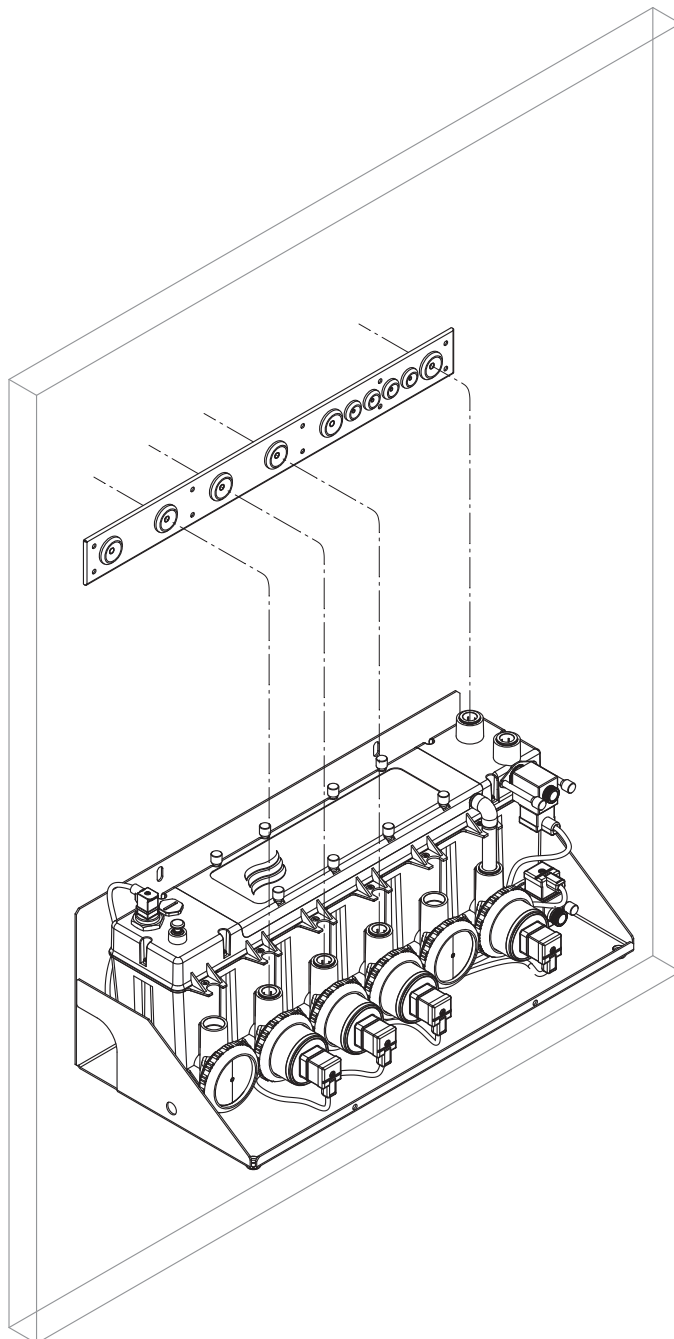


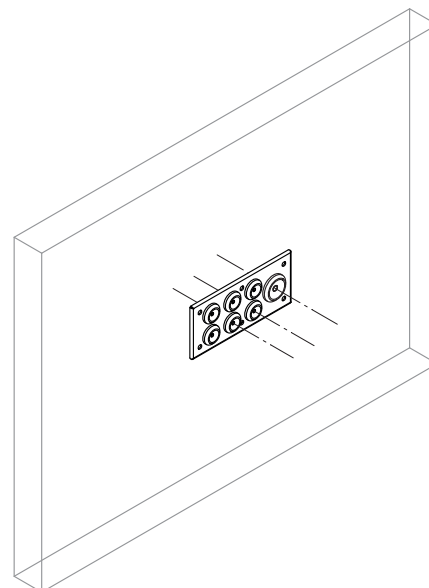
Fig. 19: Mounting the hydraulic modules (external installation)

4.4 Mounting the wall feed through plates

1. Push out or pierce the centre of grommets that will have pipes or cable passing through them. Large grommets are for pipe work, and small grommets are for cables.
Note: on feed through plates for use with externally installed hydraulics the large grommets are spaced to match the stage pipe spacing on the hydraulic module, with a wider spaced large grommet at the right end for the pressure equalisation pipe.
2. Using the feed through plate as a guide, mark where the pipes and cables will feed through the AHU wall.

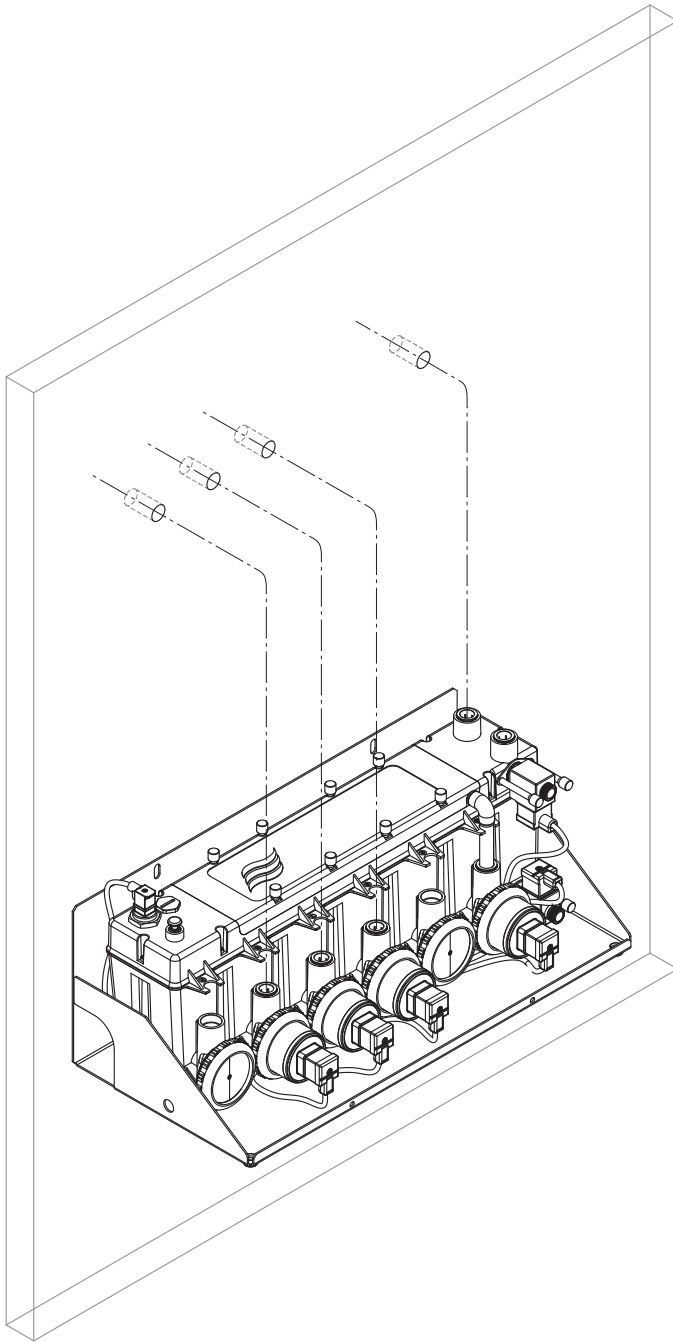


*Fig. 20: Mark feed through holes
(external installation)*

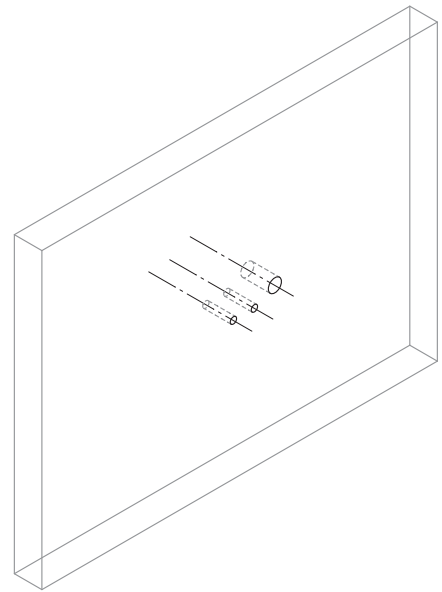


*Fig. 21: Mark feed through holes
(internal installation)*

3. Drill holes through the AHU wall for the pipes and cables. Holes should be as small as possible for the pipe or cable passing through them, and no larger than $\varnothing 12$ mm ($\varnothing 0.47$ ") for the (small) cable grommets, and $\varnothing 20$ mm ($\varnothing 0.79$ ") for the (large) pipe work grommets.



*Fig. 22: Drill feed through holes
(external installation)*



*Fig. 23: Drill feed through holes
(internal installation)*

4. Feed the pipe work (see notes in [chapter 4.5](#)) and cables through the outer feed through plate, then through the AHU wall and finally through the feed through plate on the inner side of the AHU wall.

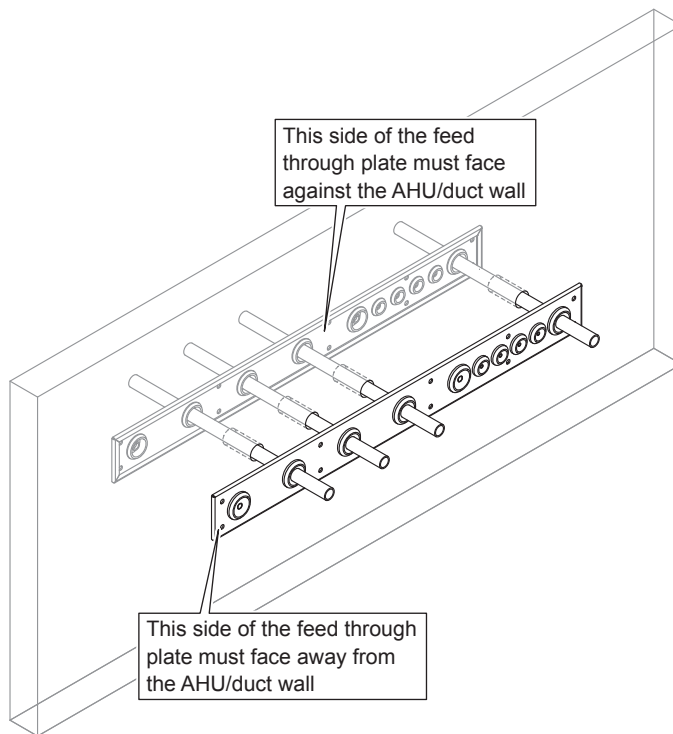


Fig. 24: Mounting the feed through plate (external installation)

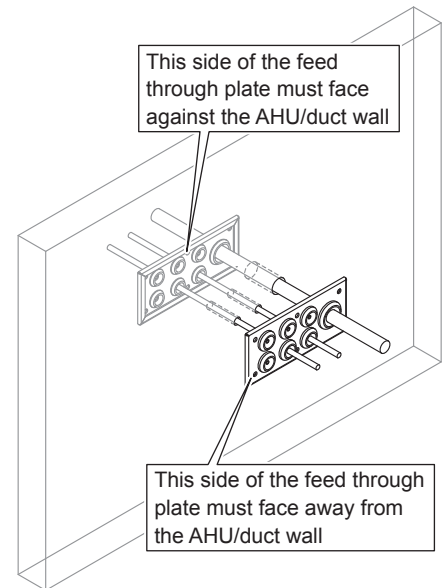


Fig. 25: Mounting the feed through plate (internal installation)

5. Screw the feed through plates to the AHU wall using appropriate fixings.

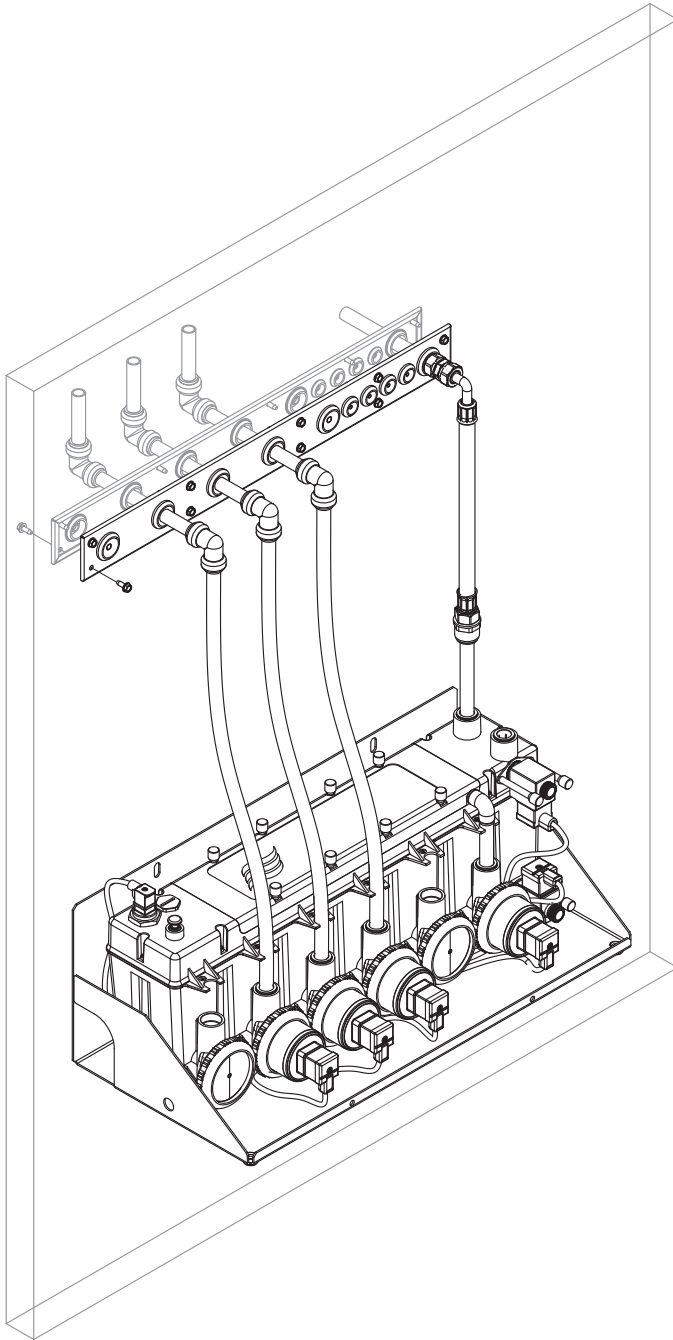


Fig. 26: Fixing the feed through plate to the duct wall (external installation)

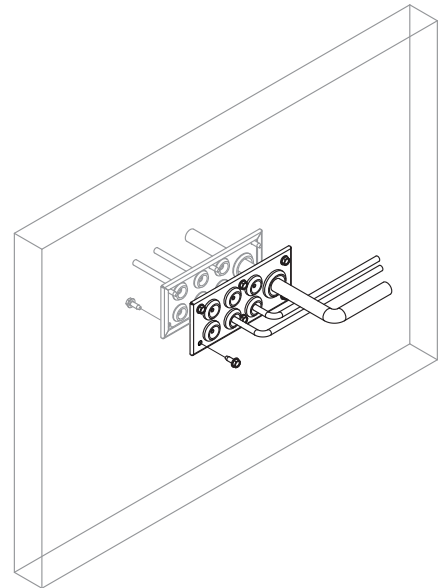


Fig. 27: Fixing the feed through plate to the duct wall (internal installation)

6. Repeat this process for the feed through plates that correspond for the second hydraulic module.

4.5 Water installation

4.5.1 Notes on water installation

The layout of the water piping (supply, drain and distribution piping) depends on the system version. Refer to the corresponding chapter for detailed information and observe the following installation notes.

– Notes on water supply

- The water supply is to be carried out according to the figures found in [chapter 4.5.2](#) and [chapter 4.5.3](#) and the applicable local regulations for water installations. The indicated connection specifications must be observed. The installation material must be supplied by the customer.
- The installation of a **shut-off valve** in the supply line is mandatory and should be made as close as possible to the hydraulic module.
- The water supply pressure should be between 2-5 bar (29-72.5 psi), a pressure regulator should be installed to control the pressure if there is a risk of the pressure exceeding this range.
- The installation material must be rated for the supply pressure and certified for use in drinking water supply systems.
- The fitting that is inserted in the water inlet port of the blue hydraulic module should not be subjected to horizontal force. Ensure that the flexible supply hose is not under tension, and will not be subjected to excessive vibration while the AHU is in operation.
- The water supply pipe for an ME Control with two hydraulic modules should be at least $\varnothing 22$ mm ($\varnothing 0.875$ "), before splitting in two separate $\varnothing 15$ mm or $\varnothing 16$ mm ($\varnothing 0.625$ ") pipes (as applicable) for the individual hydraulic modules. Do not supply more than one hydraulic module from a pipe that is less than $\varnothing 22$ mm ($\varnothing 0.875$ ") or the ME Control may not achieve the required performance.
- Regarding supply water quality see appendix.
- The wall feed through for the water supply is provided as part of the installation kit.
Important: after installation the water supply pipe has to be sealed around the feed through using silicone-free sealant, if not using a Condair supplied feed through.
- **Important! To prevent new systems being contaminated with low quality water the entire water supply line must be flushed and tested until the supply water and the bacteria counts, are in line with the water quality specifications, before connecting it to the hydraulic module.** For water quality requirements refer to [chapter 5.1](#).



CAUTION!

After cutting rigid pipes any **sharp edges must be deburred**, as sharp edges may damage the couplings and seals or cause injury.

– **Notes on water drain**

- The water drain is to be carried out according to the figures found in [chapter 4.5.2](#) and [chapter 4.5.3](#) and the applicable local regulations for water installations. The indicated connection specifications must be observed. The installation material must be supplied by the customer.
- Make sure the drain lines are installed with a constant down-slope down to the funnel.
- The drain pipes must not touch the funnel, allow air gap of min 20 mm (0.8").
- Make sure the drain pipes, the drain trap and the funnel are correctly fixed and easily accessible for inspections and cleaning purposes.
- Access hole for the drain pipe through the duct/AHU must be provided by the customer.
Important: after installation seal between drain pipes and AHU/duct wall using silicone-free sealant.
- The minimum inside diameter of the drain pipes must be maintained throughout the entire length!
- The drain pipes must be vented to the interior of the duct in accordance with the figures found in [chapter 4.5.2](#) and [chapter 4.5.3](#). The end of the drain pipe vent that is within the duct must be higher than the maximum tank water level

– **Notes on pressure equalisation for external mounted systems**

The hydraulic modules must both be equipped with a pressure equalisation pipe connected to the interior of the duct to ensure the water level in the hydraulic module corresponds with the water level in the tank inside the duct (see figure in [chapter 4.5.3](#)).

– **Notes on distribution piping**

- The distribution piping is to be carried out according to the figures found in [chapter 4.5.2](#) and [chapter 4.5.3](#) and the applicable local regulations for water installations. The indicated connection specifications and connection layout must be observed.
- The distribution piping is made of 0.625" flexible plastic hoses (supplied with internally installed systems) or stainless steel pipe/rigid plastic pipes (which can be supplied as part of an optional external installation kit).
- Make sure the distribution hoses have a constant downslope (no sagging) to the hydraulic modules and are not kinked over the entire length.

General notes on installation of the hoses (Internal Installation)

- Use the supplied 0.625" flexible plastic hoses only. For hygienic reasons do not use other hoses (except products supplied by your Condair distributor).
- When cutting hoses use an **appropriate cutting tool** providing **straight, kink-free** cuts.



CAUTION!

After cutting the hoses any **sharp edges must be deburred** otherwise the couplings may be damaged.

- The hoses must be free of kinks and other damage (longitudinal scratches or misshaped ends, in particular).
- When cutting hoses **ensure at least 25 mm (1")** is added to the required length, to ensure the hoses can be fastened correctly (down to the stop) in the push-fit couplings.
- Make sure the hoses are not kinked and pay attention to the **minimum bend radius of 100 mm (4")**.
- Do not lead hoses past hot system components (**max. ambient temperature is 60 °C/140 °F**).
- After installation verify correct fastening of all hoses. Correctly mounted hoses can not be removed without pressing the locking ring.



CAUTION!

In order to avoid damage caused by leaking water during operation, all hoses must be correctly secured against accidentally pulling out.

4.5.2 Water installation (internal installation)

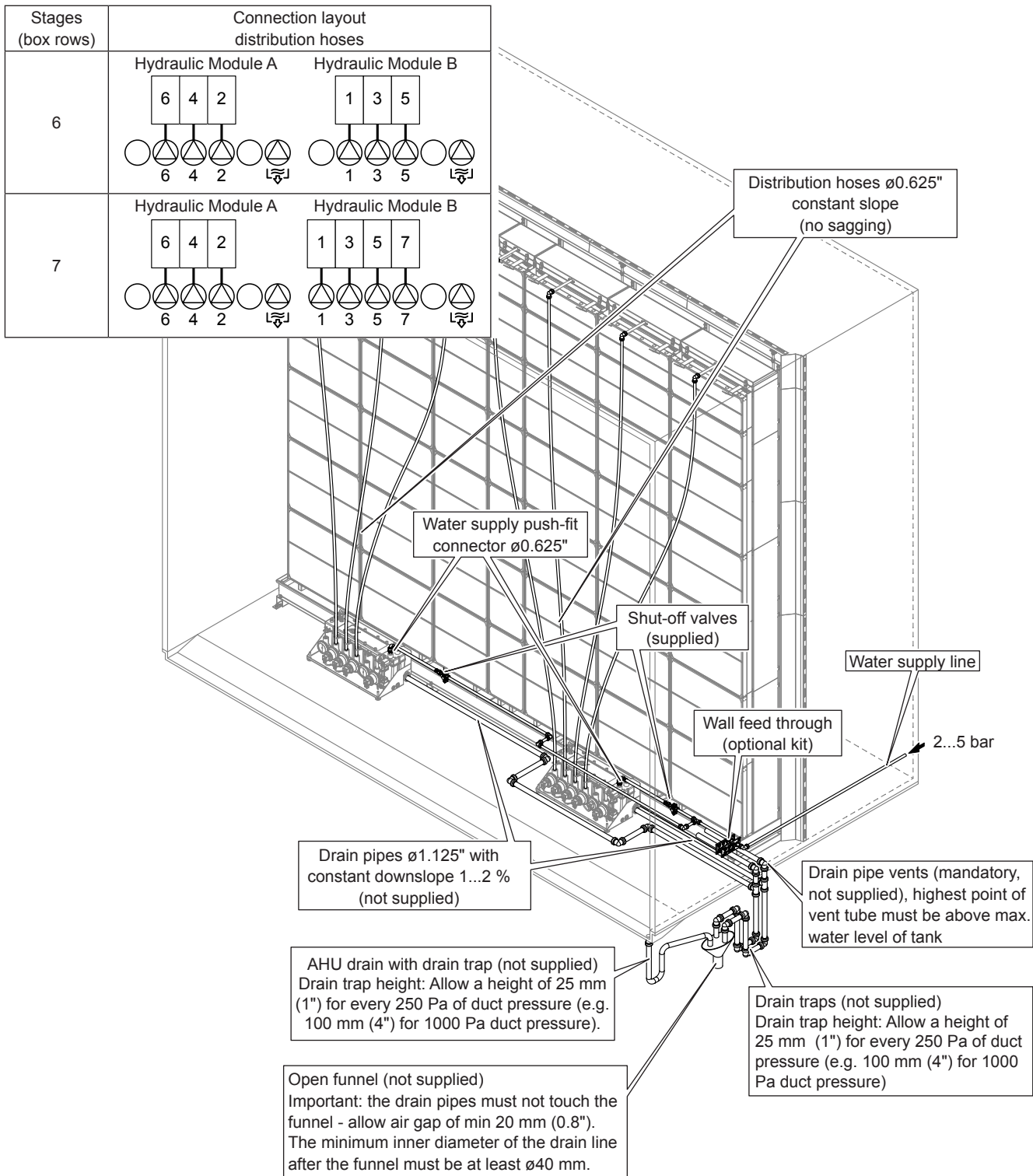


Fig. 28: Water installation (internal installation)

4.5.3 Water installation (external installation)

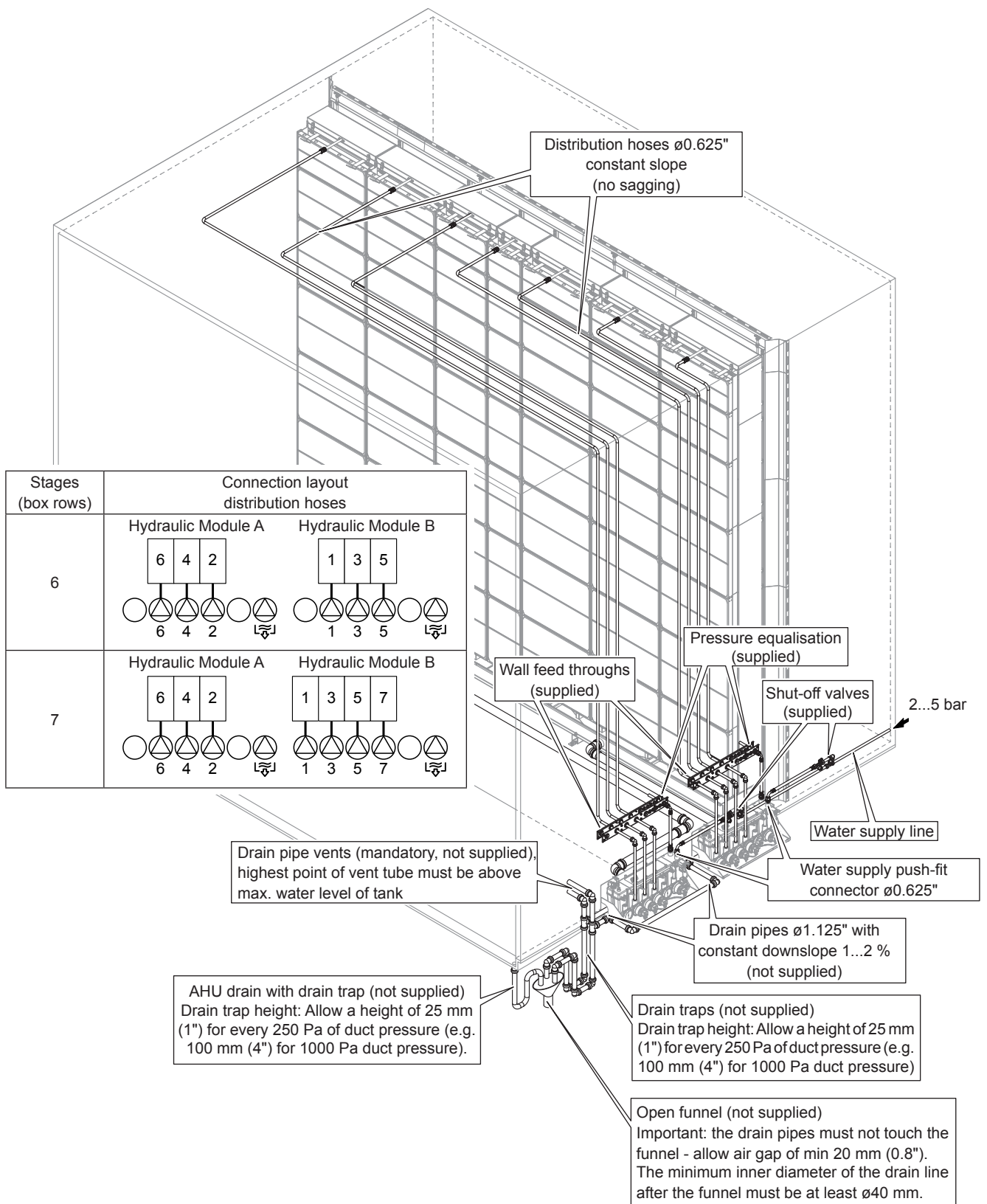


Fig. 29: Water installation (external installation)

4.5.4 Mounting the control unit

4.5.5 Notes on positioning the control unit

Please observe the following notes when positioning the Condair ME control unit:

- The control unit can be mounted directly outside to the AHU/air duct or to a wall or stand (not supplied).
- The control unit should ideally be positioned as close to the evaporative module as possible for ease of servicing and maintenance.

Note: the hydraulic modules of the Condair ME Control are equipped with a 10 m (32.8') multi-wire electrical inter-connecting cable for connection to the control unit. Make sure the control unit is mounted within the range of the inter-connecting cable.

- The control unit is protected according to **IP21**. Make sure the control unit is installed in a drip-proof location and the admissible ambient conditions are complied with (see technical data in the operation manual to the Condair ME Control).
- The power supply to the control unit must be equipped with an electrical isolator (not supplied) fitted within 1 m (39") for purposes of maintenance and emergencies. When positioning the control unit make sure the electrical isolator can be mounted within that range.

4.5.6 Recommended access requirements of the control unit

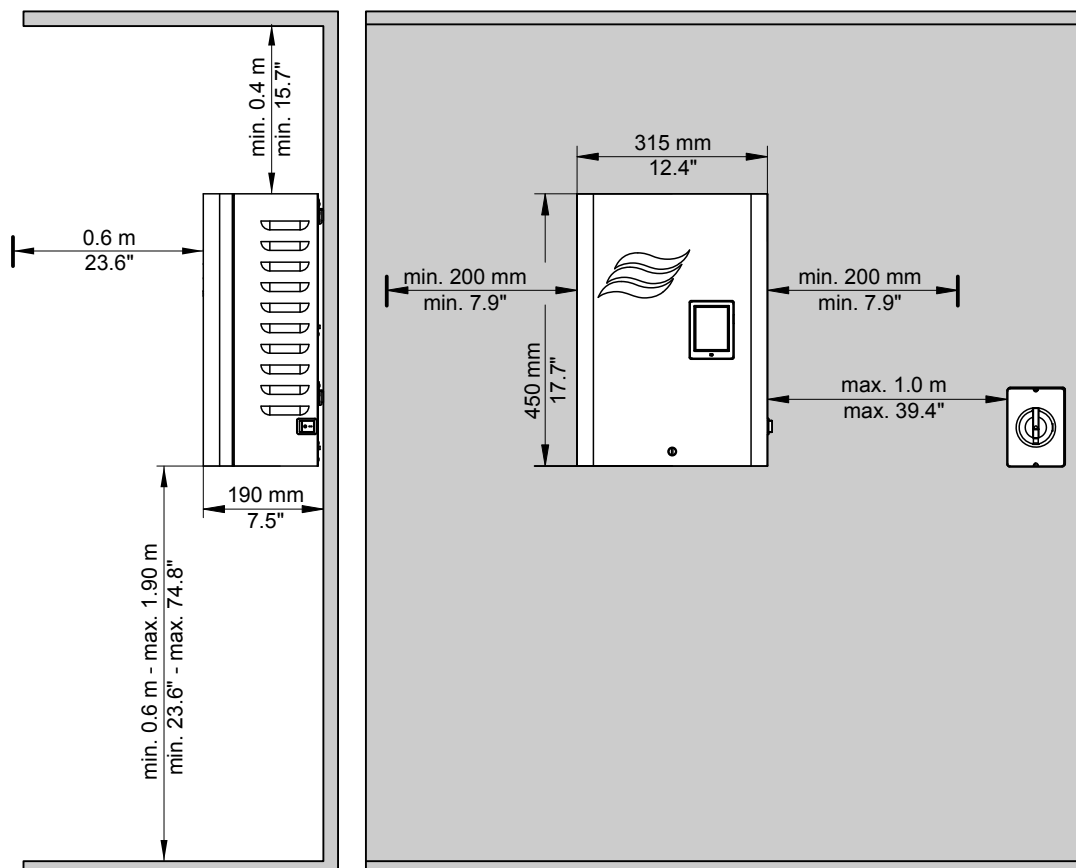


Fig. 30: Recommended access requirements of the control unit

4.5.7 Mounting the control unit

Important: if multiple systems have been supplied to a site, ensure that the serial number on the control panel corresponds to the serial number marked on the hydraulic module and the evaporative module.

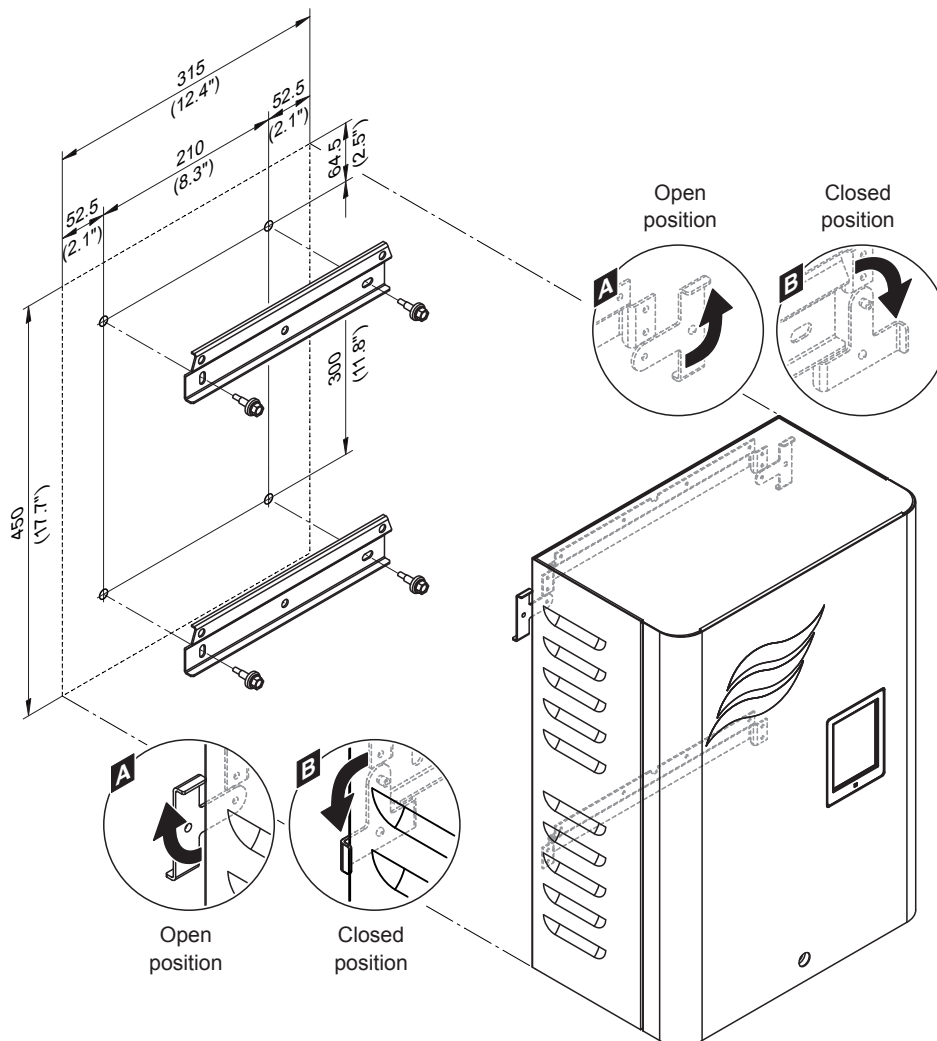


Fig. 31: Mounting the control unit of Condair ME Controls

Mounting procedure:

1. Mark the attachment points for the upper and lower wall support at the desired position with the help of a level.
2. Fix the wall supports to the wall using appropriate fixings. Before tightening the fixings adjust the wall supports horizontally using a level.
3. Move the locking hooks on the back of the control panel to open position (see [detail "A" in Fig. 31](#)).
4. Hang up the control unit onto the wall supports.
5. Move the locking hooks on the back of the control panel to closed position (see [detail "B" in Fig. 31](#)) in order to fix the control unit to the upper wall support.

4.6 Electrical installation

4.6.1 Notes on electrical installation



DANGER!
Risk of electric shock!

The control unit contains live mains voltage. Live parts may be exposed when the control unit is open. Touching live parts may cause severe injury or danger to life.

Prevention: The control unit must be isolated from the mains before commencing any installation work.



WARNING!

The **electronic components** inside the control unit are **very sensitive to electrostatic discharge**. Before carrying out installations work inside the control unit, appropriate **measures must be taken to protect the electronic components against damage caused by electrostatic discharge (ESD protection)**.

- All work concerning the electrical installation must be performed only by **skilled and qualified technical personnel (e.g. electrician or technicians with appropriate training)** authorised by the owner. It is the owner's responsibility to verify proper qualification of the personnel.
- The electrical installation must be carried out according to the wiring diagram (see [chapter 4.6.2](#)), the notes on electric installation as well as the applicable local regulations. All information given in the wiring diagram must be followed and observed.
- All cables must be led into the control unit via the cable feed throughs on the bottom side of the control unit. The mains cable must be led into the control unit via the cable opening equipped with the cable gland on the right side.

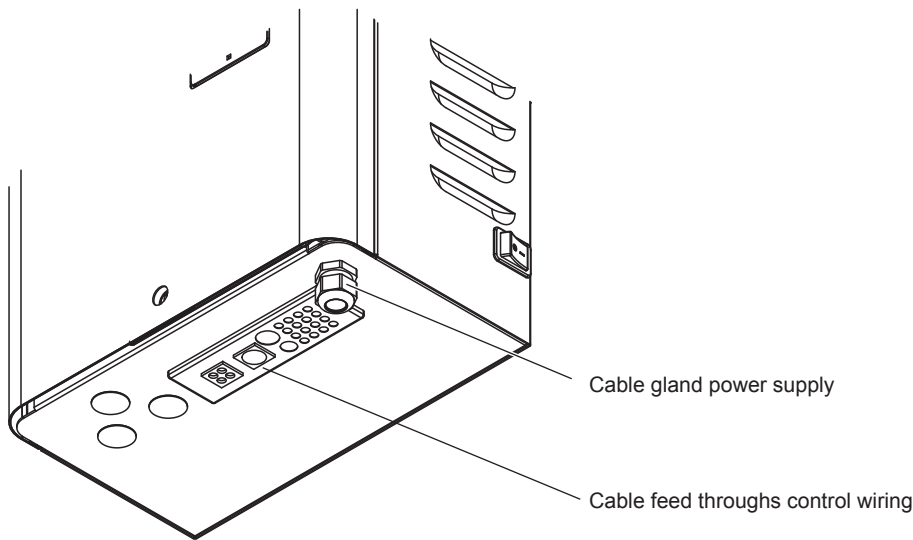


Fig. 32: Cable feed throughs control units

- All cables from the hydraulic modules mounted inside the AHU/air duct must be led via appropriate cable gland(s) out of the AHU/air duct.
- Ensure cables are secured in such a way that the insulation is not damaged by sharp edges and so that they do not create a trip hazard.
- Observe and maintain maximum cable length and required cross section per wire according to local regulations.
- The mains supply voltage must match the respective voltage stated on the rating plate.

4.6.2 Wiring diagram Condair ME Control

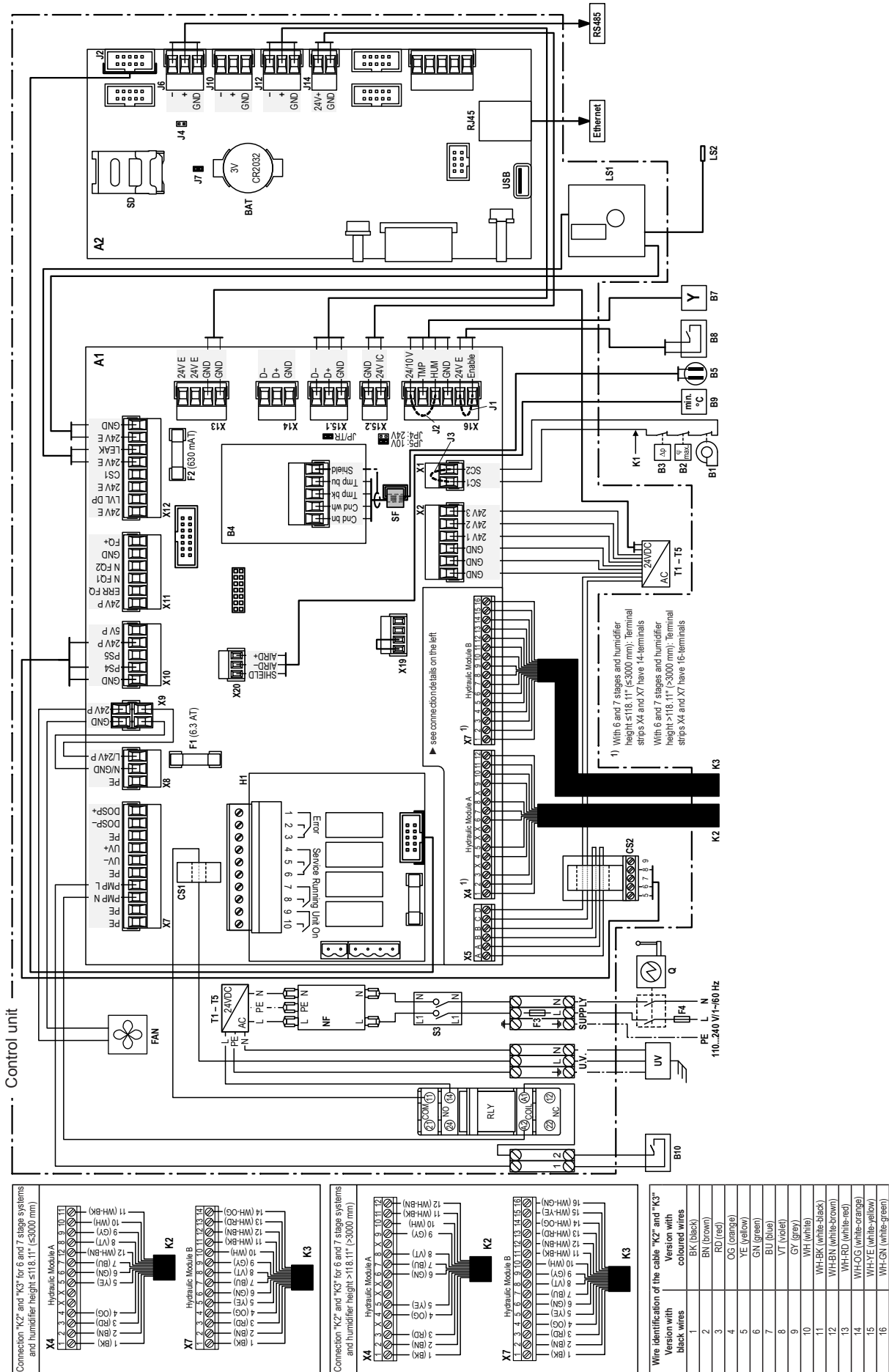


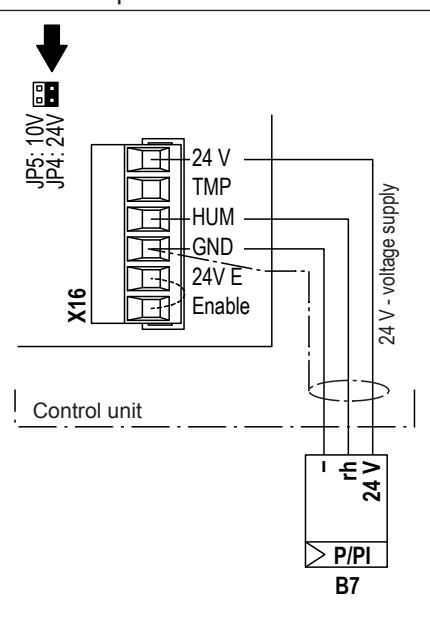
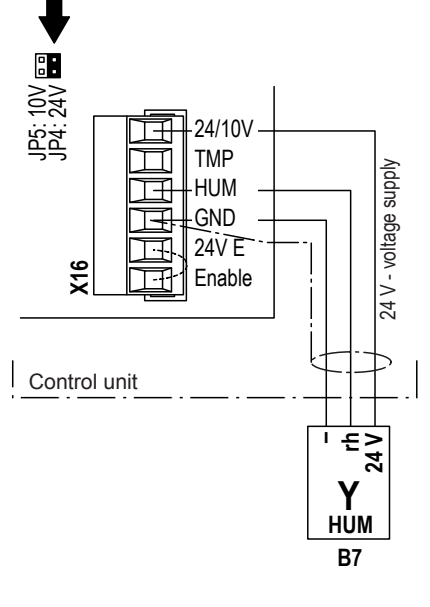
Fig. 33: Wiring diagram Condair ME Control

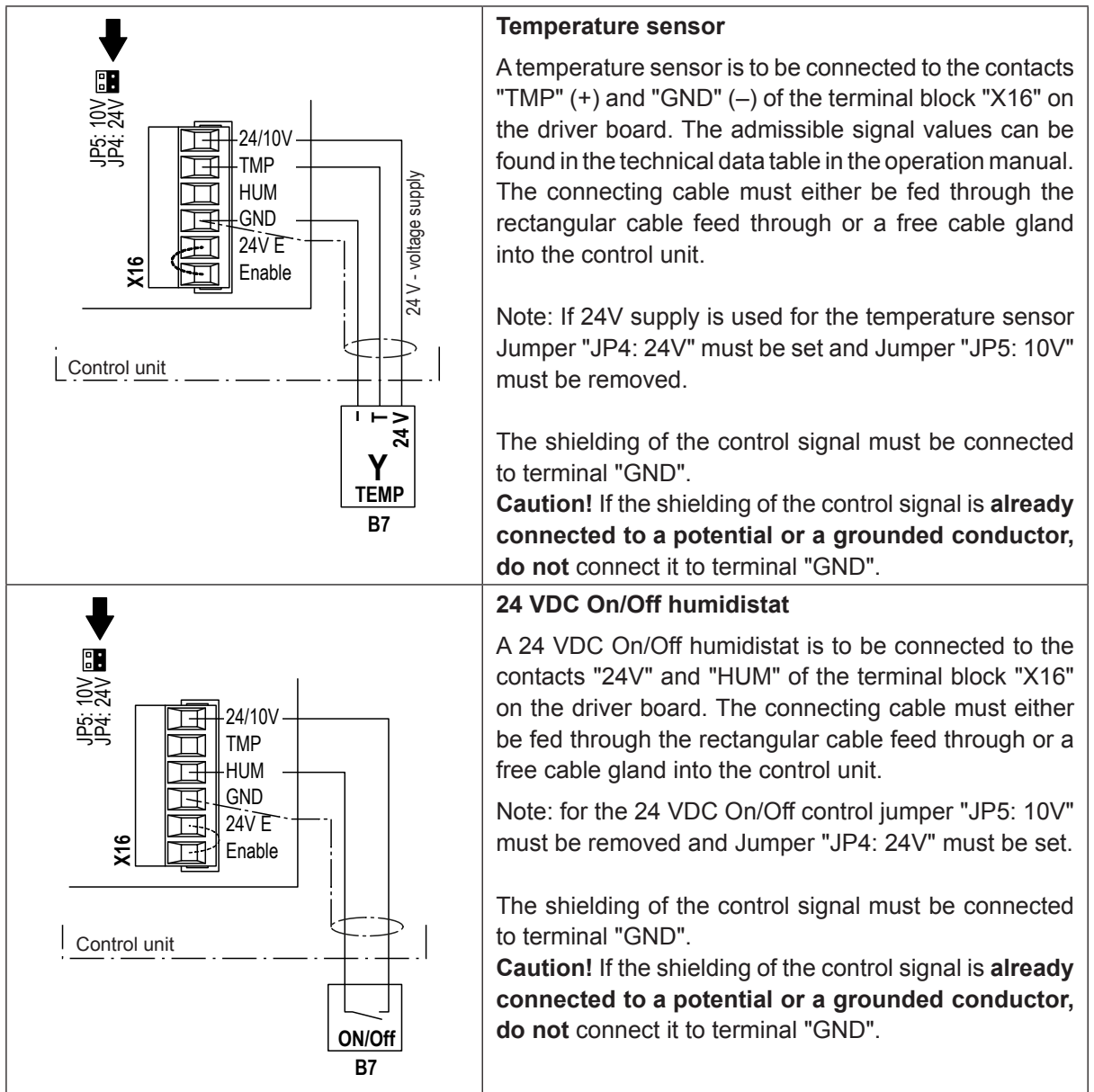
Legend wiring diagram Condair ME Control

A1	Driver board
A2	Control board
B1	Ventilation interlock
B2	Max. humidity monitor
B3	Air flow monitor
B4	Temperature and conductivity measuring
B5	Sensor temperature and conductivity measuring
B6	Level sensor dosing pump (option)
B7	Demand or humidity/temperature signal
B8	External On/Off switch (external enable)
B9	Air temperature monitoring duct (option)
B10	UV Interlock (for installation on AHU access panel/door)
BAT	Backup battery (CR2032, 3V)
CS1	Current sensor (UV lamp)
CS2	Current sensor (pump fault detection option) Note: wires must pass through the sensor in the direction shown
F1	Fuse mains supply (6.3 A slow acting)
F2	Fuse 10/24 VDC supply (630 mA slow acting)
F3	Internal fuse mains supply (10 A slow acting)
F4	External fuse mains supply (10 A slow acting)
FAN	Internal cooling fan
H1	Remote operating and fault indication board (option)
J1	Cable bridge if no external On/Off switch is connected
J2	Cable bridge demand signal (for commissioning only)
J3	Cable bridge if no safety chain is connected
J4	Jumper for activating the terminating resistor for Modbus network (Jumper must be fitted, if Condair ME is the last unit in the Modbus network)
J7	Jumper fitted: Modbus communication via RS 485 interface (J6)
JP4	Jumper fitted= 24 V on X16 (JP5 removed)
JP5	Jumper fitted= 10 V on X16 (JP4 removed)
JP/TR	Jumper fitted on the last driver board
K1	External safety chain
K2	Cable harness from hydraulic module A
K3	Cable harness from hydraulic module B
LS1	Leakage monitoring board (option)
LS2	Sensor leakage monitoring (option)
NF	Mains filter
Q	Electrical isolator
RLY	UV interlock relay
S3	On /Off switch control unit
SD	Memory card
SF	Snap ferrite (wrap cable 3 times through ferrite)
SUPPLY	Terminal mains supply voltage
T1...T5	24V power supply
UV	UV lamp (option)
U.V.	Terminal UV lamp
X4	Terminal cable harness hydraulic module A
X7	Terminal cable harness hydraulic module B
X5	Terminal current sensor (pump fault detection option)

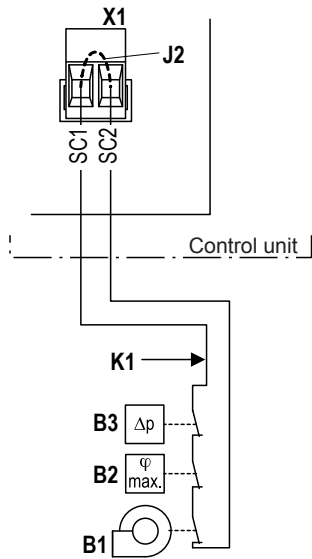
4.6.3 Installation work

Note: for the connection of the available options please refer to the addendum manual of the corresponding option.

Control signal (Y)	
<p>Note: the control settings must be done via the control software of the Condair ME Control. Please refer to the operation manual of the Condair ME Control.</p> 	<p>External continuous humidity or temperature controller</p> <p>An external continuous humidity or temperature controller is to be connected to the contacts "HUM" (+) and "GND" (-) of the terminal block "X16" on the driver board in accordance with the wiring diagram. The admissible signal values can be found in the technical data table in the operation manual. The connecting cable must either be fed through the rectangular cable feed through or a free cable gland into the control unit.</p> <p>Note: If 24V supply is used for the external controller Jumper "JP4: 24V" must be set and Jumper "JP5: 10V" must be removed.</p> <p>The shielding of the control signal must be connected to terminal "GND". Caution! If the shielding of the control signal is already connected to a potential or a grounded conductor, do not connect it to terminal "GND".</p>
	<p>Humidity sensor</p> <p>A humidity sensor is to be connected to the contacts "HUM" (+) and "GND" (-) of the terminal block "X16" on the driver board. The admissible signal values can be found in the technical data table in the operation manual. The connecting cable must either be fed through the rectangular cable feed through or a free cable gland into the control unit.</p> <p>Note: If 24V supply is used for the humidity sensor Jumper "JP4: 24V" must be set and Jumper "JP5: 10V" must be removed.</p> <p>The shielding of the control signal must be connected to terminal "GND". Caution! If the shielding of the control signal is already connected to a potential or a grounded conductor, do not connect it to terminal "GND".</p>



External safety circuit



To guarantee the safety of the humidification/cooling system, monitoring the operation by means of a safety circuit "K1" is an absolute requirement.

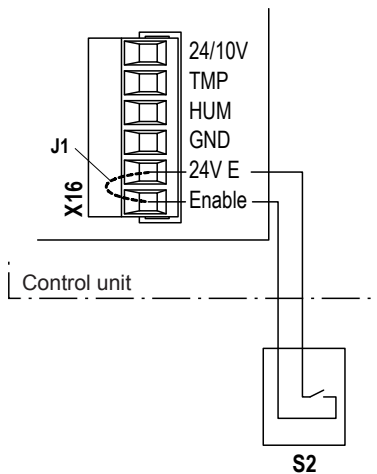
To accomplish this, the **potential-free contacts** of external monitoring devices (e.g. ventilation interlock "B1", safety high limit humidistat "B2", airflow monitor "B3", etc.) are **connected in series to the contacts "SC1" and "SC2" of the terminal block "X1"** on the driver board in accordance with the wiring diagram. The connecting cable must either be fed through the rectangular cable feed through or a free cable gland into the control unit.

If, for whatever reason, no external monitoring devices are connected, a cable bridge "J2" must be installed on the contacts "SC1" and "SC2" of the terminal block "X1".

Do not apply any **extraneous voltage** to contacts **"SC1" and "SC2"** via the contacts of the external monitoring devices.

The cross-section of the connecting cable must comply with the applicable local regulations (minimum 1 mm²).

External enable



The **potential-free contact** of an external enable switch is **connected to the contacts "24 V E" and "Enable" of the terminal block "X16"** on the driver board in accordance with the wiring diagram. The connecting cable must either be fed through the rectangular cable feed through or a free cable gland into the control unit.

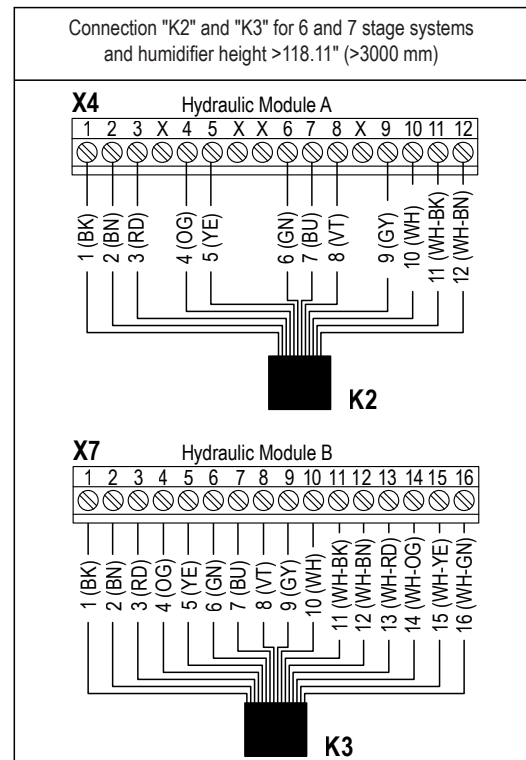
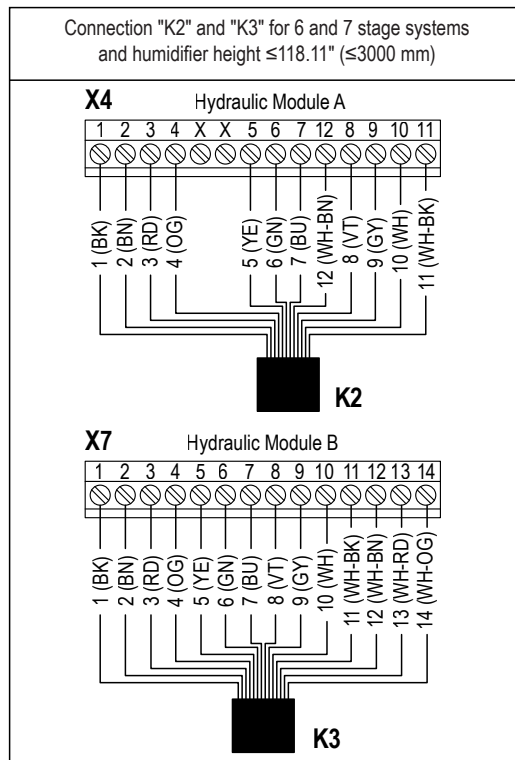
If no external enable switch is connected, a cable bridge "J1" must be installed on the contacts "24V E" and "Enable" of the terminal block "X16".

CAUTION! Do not apply any extraneous voltage to terminals via the enable switch.

Connecting the multi-wire inter-connecting cable from the hydraulic module

Note: The multi-wire inter-connecting cables are supplied with numbered black wires or colored wires. When connecting the multi-wire inter-connecting, observe the table below with the identification of the wires.

Wire identification of the cable "K2" and "K3"	
Version with numbered black wires	Version with coloured wires
1	BK (black)
2	BN (brown)
3	RD (red)
4	OG (orange)
5	YE (yellow)
6	GN (green)
7	BU (blue)
8	VT (violet)
9	GY (grey)
10	WH (white)
11	WH-BK (white-black)
12	WH-BN (white-brown)
13	WH-RD (white-red)
14	WH-OG (white-orange)
15	WH-YE (white-yellow)
16	WH-GN (white-green)



The multi-wire inter-connecting cable "K2" from the hydraulic module A is to be connected to the corresponding terminals of terminal block "X4" and the multi-wire inter-connecting cable "K3" from the hydraulic module B is to be connected to the corresponding terminals of terminal block "X7" according to the appropriate wiring diagrams shown above. The multi-wire inter-connecting cables must be fed through the rectangular cable feed through into the control unit.

The 33 ft (10 m) multi-wire inter-connecting cable has to be cut to length on site. If terminal block "X4" has 14 terminals, and "K2" has 16 coloured wires, cut back the 2 unused wires.

Once the multi-wire inter-connecting cables from the hydraulic modules have been cut to the required length, set the potentiometers on the distribution board to the number that corresponds to the length of the relevant inter-connecting cable in metres, as explained below:

Systems with 3 potentiometers (3 m or less tall):

Potentiometer 1 = Length of cable "K2"

Potentiometer 2 = Length of cable "K3"

Potentiometer 3 = Length of cable "K3"

Systems with 4 potentiometers (over 3 m tall):

Potentiometer 1 = Length of cable "K2"

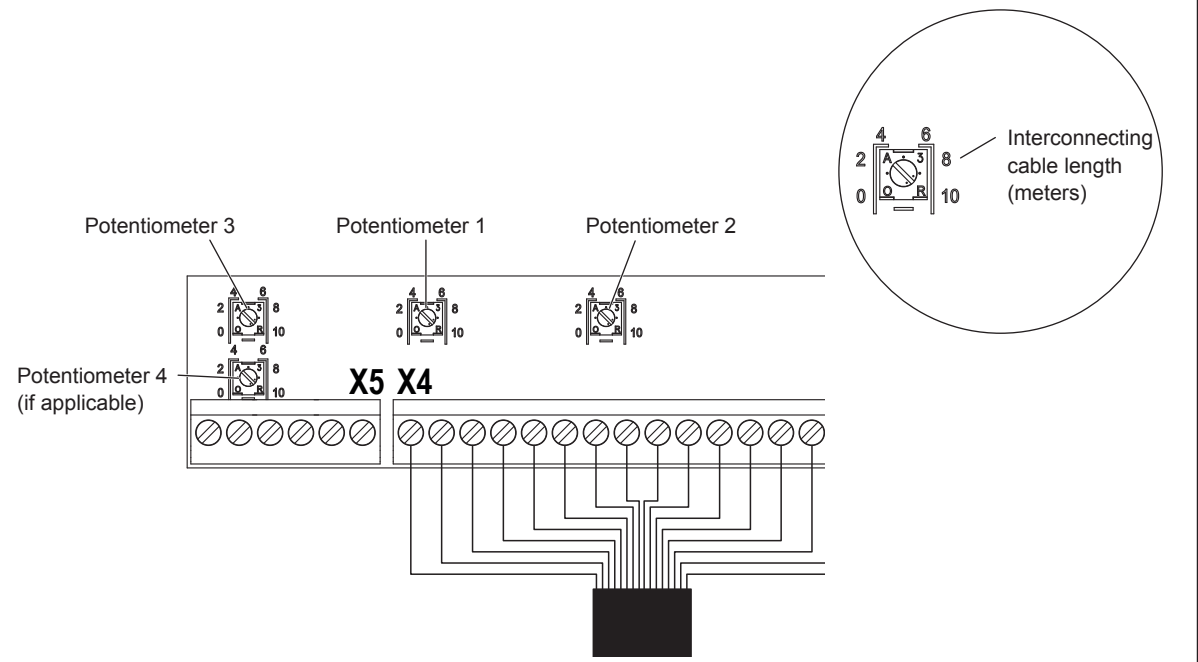
Potentiometer 2 = Length of cable "K2"

Potentiometer 3 = Length of cable "K3"

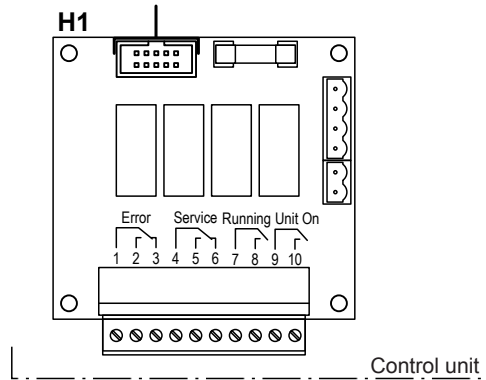
Potentiometer 4 = Length of cable "K3"

Cable "K2" is the multi-wire inter-connecting cable from hydraulic module A.

Cable "K3" is the multi-wire inter-connecting cable from hydraulic module B.



Connecting the remote operating and fault indication (option)



The optional remote operating and fault indication board contains four potential-free relay contacts for the connection of the following operating and fault indications:

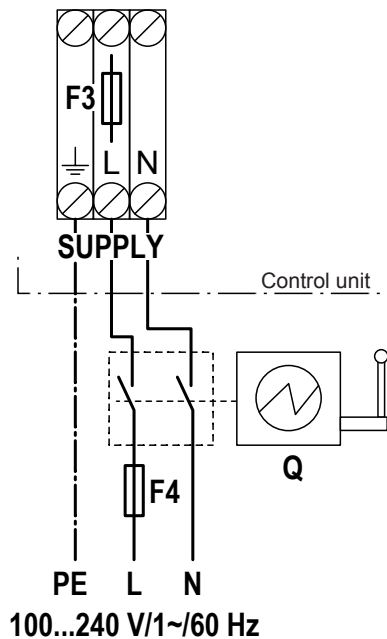
- "Error":
This relay is activated if an error is present.
- "Service":
This relay is activated when the set service interval has expired.
- "Running" (Humidification/Cooling):
This relay closes as soon as the Condair ME is humidifying/cooling.
- "Unit on":
This relay closes as soon as the voltage supply to the control unit of the Condair ME is switched on.

The connecting cable must either be fed through the rectangular cable feed through or a free cable gland into the control unit.

The **maximum contact loading is 250V/8A.**

Appropriate suppressor modules are to be used for the switching of relays and miniature contactors.

Mains voltage supply



CAUTION! Before connecting the mains voltage supply, make sure the voltage indicated on the rating plate meets the local line voltage. Otherwise, do not connect the control unit.

Connect **mains voltage supply** 100...240 V/1~/60 Hz in accordance with the wiring diagram, to the **terminal block "SUPPLY"** in the control unit. The mains supply cable must be led into the control unit via the cable gland on right side on the bottom of the control unit.

The installation of the **fuse F4** (10A, slow acting), the **electrical isolator "Q"** (all pole disconnecting device with a minimum contact clearance of 3 mm/0.12") and a fault current protection switch with 30 mA trigger current (by client) in the mains supply line **are mandatory.**

The electrical isolator must be mounted in direct proximity of the control unit (max. distance 1 m/39.37") and must be easily accessible in a height between 0.6 m/23.62" and 1.9 m/74.8" (recommended: 1.7 m/66.93").

The cross-section of the mains cable must comply with the applicable local regulations (min. 1.5 mm²/0.0023 sq.in.).

5 Appendix

5.1 Inlet water quality requirements

Condair recommends that the Condair ME must be connected to a **clean, wholesome (drinking water quality) mains water supply**. For areas of hard water and to minimise scale build up the water supply may be treated by a reverse osmosis system (RO).

Reverse Osmosis

For Condair ME systems supplied with RO water it is recommended that the system is operated within the following parameters. The use of RO water fed tanks and reservoirs is only permitted as part of a managed and hygiene monitored water system and should form part of the water system risk assessment.

System	Conductivity
Condair ME Control	> 5 $\mu\text{S cm}^{-1}$ at 20 °C (68 °F)

Other Water Supplies

There is a growing demand to utilise sustainable water sources to help overcome scarcity challenges and recycle water. It is possible to use high-quality, treated effluent for non-wholesome applications. The following gives guidance on reclaimed water quality that may be acceptable for use within the Condair ME. "Effluent treated water", must be treated by an appropriate water treatment method and risk assessed to ensure it is safe and suitable for use in the Condair ME unit. It is the responsibility of the user to ensure that the water supply system is part of a managed, hygiene monitored water system, risk assessed and complies with the local regulations and bylaws.

Below are example water conditions that would allow a Condair ME to operate within specification.

Parameter	Content in supply water	Concern
Temperature	< 20 °C (68 °F)	Warm water favours growth of bacteria
Aluminium	-	No specific concerns
Ammonium	< 0.50 mg/l	Odour passed to air
Calcium	< 300 mg/l	Scale formation
Chloride	< 300 mg/l	Corrosion of stainless steel
Colour	None	Not directly a concern
Copper	< 1 mg/l	Deposits and corrosion stimulation
Conductivity	< 650 $\mu\text{S cm}^{-1}$ at 20°C (68 °F)	Total hardness and scale formation.
pH	6.5 to 9.5	Acid or Alkali damage to equipment.
Iron	< 0.5 mg/l	Deposit formation on oxidation and a critical support role in Legionella growth.
Manganese	< 0.1 mg/l	Deposit formation
Nitrate	-	No specific concerns
Nitrite	-	No specific concerns
Odour	Acceptable to users	Smell passed to air
Sulphate	< 250 mg/l	No specific comments
Sodium	-	No specific concerns
Total organic carbon	-	No specific concerns

Parameter	Content in supply water	Concern
Turbidity	< 5 NTU	No specific concerns
Colony count 22°C	< 1000 cfu/ml	Indicator of contaminated water supply
Coliform bacteria	< 10 cfu/100 ml	Indicator of poor water quality
Legionella bacteria	< 50 cfu/1000 ml	Risk of Legionella
Pseudomonas species	< 10 cfu/100 ml	Indicator of slime forming potential



DANGER!

Failure to ensure the quality of the supply water may endanger the health of individuals exposed to the ME system, the air from the AHU/air duct, or the water from the ME system. Poor supply water quality may also encourage the growth of micro-organisms (including the bacterium which causes Legionnaire's disease).

Controlled Substances



DANGER!

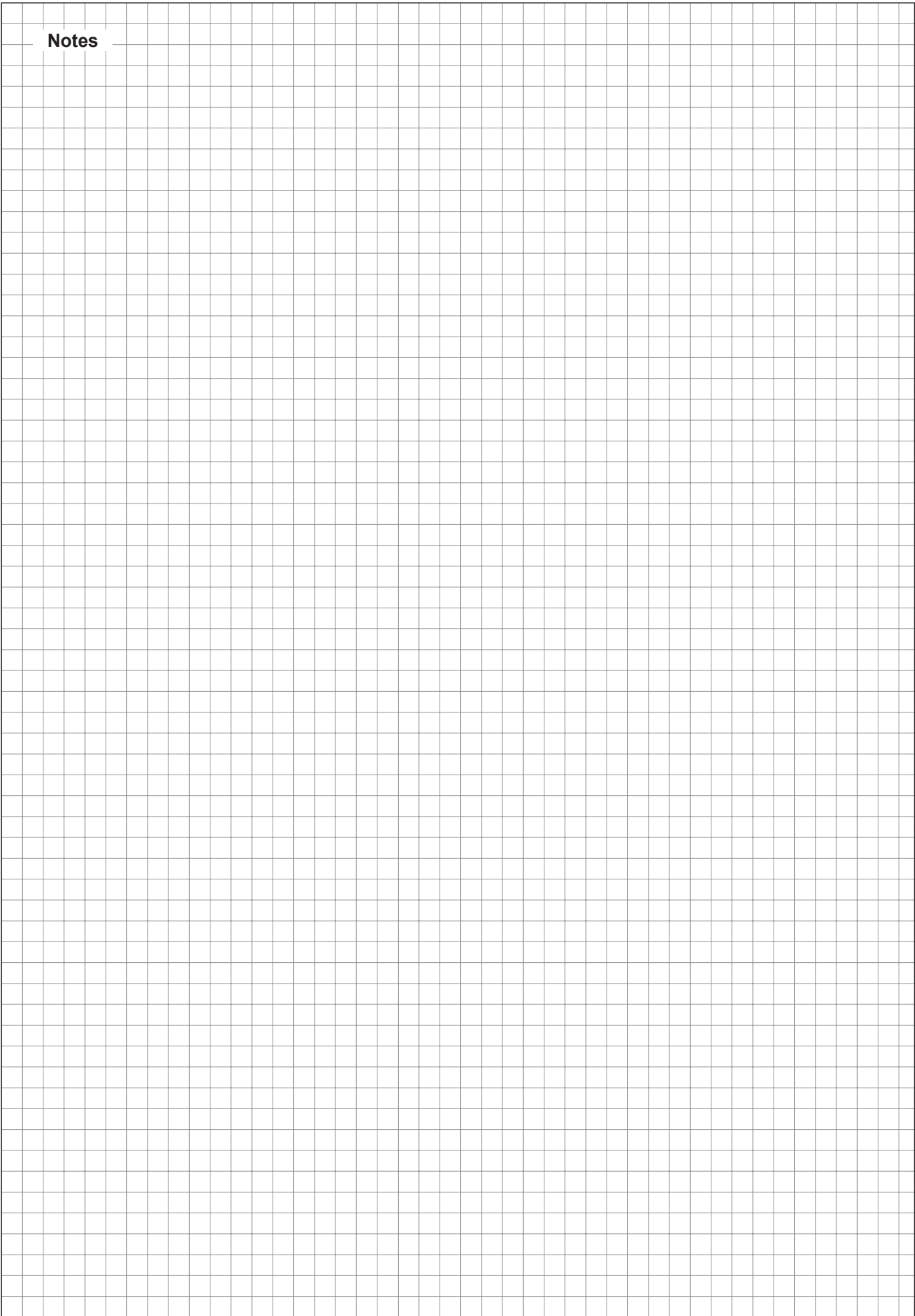
Many of the following controlled substances could present a risk to health; for example vinyl chloride is highly toxic, flammable and carcinogenic and could be evaporated off the evaporative matrix from contaminated water and passed to the airflow. Therefore it is important to note that any supply water coming from complex waste water which may contain the following contaminants should be carefully risk assessed by a water treatment specialist.

Controlled substances
Clostridium perfringens (including spores)
Acrylamide
Antimony
Arsenic
Benzene
Benzo(a)pyrene
Boron
Bromate
Cadium
Chromium
Cyanide
1,2-dichloroethane
Epichlorohydrin
Fluoride
Lead
Mercury
Nickel
Pesticides
Polycyclic aromatic hydrocarbons
Selenium
Tetrachloroethene and Trichloroethene
Trihalomethanes
Vinyl chloride

Water Monitoring

The Condair ME water system must be monitored for hygiene as part of the maintenance programme.

Notes



Warranty

Condair Inc. or Condair Ltd. (depending on the entity that supplied the product, and hereinafter collectively referred to as CONDAIR) warrant for a period of two years after installation or 30 months from the manufacturer's ship date, whichever date is earlier, that CONDAIR's manufactured and assembled products, not otherwise expressly warranted, are free from defects in materials and workmanship. Notwithstanding the foregoing, the products listed below have an alternate warranty period:

- GS/GSTC Series heat exchanger(s) are warranted to be free from defects in materials and workmanship for a period of 3 years from installation or 40 months from the manufacturer's ship date, whichever is earlier.
- SAM-e Short Absorption Manifolds, except for the coupling seals, are warranted to be free from defects in materials and workmanship for a total period of 10 years from the manufacturer's ship date.
- Humilife RH humidifiers are warranted to be free from defects in materials and workmanship for a period of 5 years from the manufacturer's ship date. CONDAIR may, at its discretion, replace individual components or Humilife RH units as a whole.
- Spare Parts used for repairs are warranted for the balance of the term of the warranty on the original humidifier or 90 days, whichever is longer.
- No warranty is made against corrosion, deterioration, or suitability of substituted materials used as a result of compliance with government regulations.

CONDAIR's obligations and liabilities under this warranty are limited to furnishing replacement parts to the customer, F.O.B. CONDAIR's factory. The replacement parts are warranted for the balance of the term of the warranty on the original humidifier or 90 days, whichever is longer. Procedure:

1. Customer Requests Warranty as per instructions on the CONDAIR Warranty Form.
2. CONDAIR reviews the warranty claim and will respond in one of two ways:
 - a. Warranty Accepted – Replacement Part or credit granted.
 - b. Warranty Declined – Response with justification will be provided to the customer.
3. In some cases, CONDAIR may request the part to be returned, freight prepaid by the customer, as part of the warranty acceptance or warranty determination process. Some reasons include:
 - a. Part must be analyzed to determine the root cause of failure.
 - b. Part must be returned to the supplier for claim/investigation.

When parts are requested to be returned, replacement parts will be sent by CONDAIR to the customer against an invoice from CONDAIR paid by the customer. The cost of the replacement parts will be reimbursed to the customer with a credit note after the parts are received and analyzed by CONDAIR, if the warranty is accepted.

The warranties set forth herein are in lieu of all other warranties expressed or implied by law. No liability whatsoever shall be attached to CONDAIR until said products have been paid for in full and then said liability shall be limited to the original purchase price for the product. Any further warranty, with the exception of a purchased extended warranty described below, must be in writing, and signed by an officer of CONDAIR.

CONDAIR makes no warranty and assumes no liability unless the equipment is installed in strict accordance with the installation manual in effect at the date of purchase, and by properly qualified and licensed professionals capable of installing such equipment.

CONDAIR makes no warranty and assumes no liability whatsoever for consequential damage or damage resulting directly from misapplication, incorrect sizing, or lack of proper maintenance of the equipment.

CONDAIR makes no warranty and assumes no liability whatsoever for damage to the products, humidifier, supply lines, drain lines, steam distribution systems, or the building as a whole caused by freezing.

CONDAIR reserves the right to change the design, specifications, and performance criteria of its products without notice or obligation.

Extended Warranty

Extended warranties are available to purchase under the conditions listed above. Extended warranties must be purchased at the time of the original equipment order.



www.condairparts.com

Buy authentic Condair
parts factory direct.

Would you recommend Condair?
Take our two question survey.



U.S.A.
1021 6th Street
Racine, WI 53403

CANADA
2740 Fenton Road
Ottawa, Ontario K1T 3T7

TEL: 1.866.667.8321
EMAIL: na.info@condair.com
WEBSITE: www.condair.com



 **condair**