

Homeowner's Manual

Condair HumiLife – The economic solution for forced air heating

Condair RE

Thank you for choosing Condair

Proprietary Notice

This document and the information disclosed herein are proprietary data of Condair Ltd. Neither this document, nor the information contained herein shall be reproduced, used, or disclosed to others without the written authorization of Condair Ltd., except to the extent required for installation, operation or maintenance of the customer's equipment.

Liability Notice

Condair Ltd. does not accept any liability due to incorrect installation, maintenance or operation of the equipment, or due to the use of parts/components/equipment that are not authorized by Condair Ltd.

Copyright Notice

Copyright 2020, Condair Ltd., All rights reserved.

Technical modification rights reserved.

1 Introduction

1.1 Getting Started

Thank you for purchasing the Condair HumiLife RE.

The Condair HumiLife RE incorporates the latest technical advances and meets recognized safety standards. Improper use of the Condair HumiLife RE may result in danger to the user or third parties, and/or damage to property.

To ensure safe, proper, and efficient operation of the Condair HumiLife RE, please observe and comply with all information and safety instructions contained in this manual, as well as all relevant documentation of components of the installed humidification system.

If you have additional questions, please contact us by visiting www.condairhumilife.com.

1.2 General

1.2.1 Symbols Used in This Manual

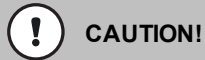

The word "CAUTION" in conjunction with the general caution symbol is used to provide safety instructions that, if neglected, may cause damage or malfunction of the unit, or damage to property.



The word "WARNING" in conjunction with the general warning symbol is used to provide safety instructions that, if neglected, may cause injury to personnel. Other specific warning symbols may also be used in place of the general symbol.



The word "DANGER" in conjunction with the general danger symbol is used to provide safety instructions that, if neglected, may cause severe injury to personnel or even death. Other specific danger symbols may also be used in place of the general symbol.

1.2.2 Storage of Manual

Keep this manual in a place where it is safe and readily accessible. If the equipment is moved to another location, please ensure that it remains with the equipment.

If the manual is lost or misplaced, please contact Condair for a replacement.

1.3 Safety Precautions

Regard all safety precautions described in this manual. Refer to ["For Your Safety" on page 4](#).

1.4 Compliance

Follow all local guidelines and regulations regarding the installation and operation of the unit; this includes (and not limited to) mounting, plumbing, water, gas, ventilation, and electrical connections.

Please consult Condair to learn more.

2 For Your Safety

General

Every person who is tasked with the installation, operation and/or maintenance of the Condair HumiLife RE must read and understand this manual, as well as any respective installation, operation and/or maintenance manuals before performing any work. Knowing and understanding the contents of these manuals is a basic requirement for protecting personnel against any kind of danger, preventing faulty operation, and operating the unit safely and correctly.

All labels, signs and markings applied to unit must be observed, kept in a readable state, and NOT removed or altered.

Intended Use

The Condair HumiLife RE is intended exclusively for air humidification using Condair-approved parts within specified operating conditions. Refer to the Operation and Maintenance manual for details. Any other type of application, without the express written consent of Condair, is considered to be NOT conforming to its intended purpose, and may lead to dangerous operation and will void the warranty.

In order to operate the equipment in the intended manner all information contained in this manual, in particular the safety instructions, must be observed closely.

Safety Precautions that Must be Observed



CAUTION: Servicing

- Disconnect power before any servicing.
- Electrical compartment contains low voltage components.
- Condair does not accept any liability for installations of humidity equipment installed by unqualified personnel, or the use of parts, components, or equipment that are not authorized or approved by Condair.



CAUTION: Electrical

- All electrical work should be done according to all applicable local and national codes.



CAUTION: Plumbing

- (Recommended) Plumbing to be performed by a licensed plumber.
- All plumbing work should be done according to local plumbing code.



CAUTION: Installation

- Do NOT mount in area where freezing can occur.
- Do NOT mount on vibrating surface.
- Do NOT mount on the floor.
- (Recommended) Install an air proving switch.

Preventing Unsafe Operation

All personnel working with the Condair HumiLife RE must immediately report to the customer any alterations or changes to the unit that may affect safety, and **secure the unit against accidental power-up**.

If it is suspected that the unit cannot be operated safely for any of the reasons listed below, shut it down immediately.

Alterations and changes that may affect safe operation include:

- damage to the unit
- loose or damaged electrical connections
- improper operation
- leaks in the distribution system

Modifications to the Unit Prohibited

Modifications are NOT permitted on the Condair HumiLife RE without the express written consent of Condair.

3 Connecting to the Condair HumiLife App

Once the humidifier is mounted, and water, drain, and wiring connections have been established, you can turn on the unit and control it with the Condair HumiLife app on your mobile device.

If the humidifier installation has not yet been completed, please refer to the installation manual to finalize the installation before proceeding.

3.1 Downloading the Condair HumiLife App

Use your phone's camera or QR scanner to go to Google Play (Android) or the App Store (iOS).

Google Play (Android)



App Store (iOS)



3.2 Connecting to the Condair HumiLife App

1. Download and install the Condair HumiLife app from the App Store or Google Play Store. Ensure your mobile device is connected to your home Wifi network.
2. Turn on your humidifier (press and hold the power button for 2 seconds).
3. Open the Condair HumiLife app. You enter a screen allowing you to choose a humidifier to connect. On the app, press **Add Device**. Your mobile device will begin to scan the area for the Condair HumiLife RE.
4. On the humidifier, press and hold the power button for 5 seconds. The wireless light  will flash green. The humidifier will be discoverable to the app.
5. Follow the instructions in the Condair HumiLife app to finalize the connection.
6. The wireless light remains solid blue once completed. A red light indicates a disconnect.

4 How to Use Your Humidifier

4.1 User Interface Controls

You must use the Condair HumiLife app to operate the humidifier.



Power



WiFi



Change Media



Alert

Power

The power light shines solid blue when the humidifier is operational. When in standby mode, the light will fade blue if there is no demand, and the light will fade red if humidification is stopped through the app. The light blinks if the security loop is open (ex. air proving switch detects no air flow).

To turn on/off the humidifier:

- Press the button on the front of the humidifier for 2 seconds.
 - » The unit will begin to power up and if there is a call for humidity, water will pulse through the unit and enter the ceramic media where it will begin humidifying the return air.
 - » If the button is pressed while the humidifier is on, the unit will stop humidifying and water is shut off from the unit.

Wireless

You can control the humidity of your home by using the Humilife app. The humidity setpoint may be changed at home or away, as long as you are connected to the internet (cloud).

While the humidifier is in AP (hotspot) mode, it will directly connect to the smartphone. After establishing the connection between the two devices, the humidifier connects to the internet.

To set the humidifier to AP mode:

- Press and hold the power button for 5 seconds.
 - » The unit attempts to establish a connection. During this time, the WiFi light will blink green. A solid green light indicates a complete connection.

To connect to the internet:

- Once AP mode is activated (solid green light), follow the on-screen instructions on the Condair HumiLife app. Enter your home WiFi network ID and password. The unit attempts to establish a connection to the internet. During this time, the WiFi light will blink blue. A solid blue light indicates a complete connection. If the connection fails, the light will turn red.
Note: during a software update, the blue WiFi light will fade.

Change Media

This light indicates the status of the ceramic media. A blue light indicates proper operation. A yellow light indicates the ceramic media must be changed soon, and a red light indicates an error.

Alerts

If there is an issue with the humidifier, the Alert light will turn on and an alert will appear in the Condair Humilife app. For a yellow light, refer to the app or the Operation manual. A red light indicates an error.

It is important to heed the warnings on the app to ensure the safe and optimum performance of the humidifier. Review the Condair HumiLife app to see what's wrong and find troubleshooting tips.

5 Understanding the Main Page

The screenshot shows the main page of the Condair mobile application. At the top is a blue header with the Condair logo and the word "Status". Below this is a section titled "My Home" which contains a large image of a white Condair humidifier unit. A line from the right points to this image with the text "Swipe to show other connected devices". Below the image are several controls: a box showing "29 % r.H." with a line from the left pointing to it and the text "Actual (relative) Humidity"; a line graph icon with a line from the right pointing to it and the text "View the humidity level history"; a horizontal slider set to "45%" with a line from the left pointing to it and the text "Move the slider* to adjust your desired humidity level (setpoint)"; and a toggle switch labeled "Humidification" which is currently turned on, with a line from the right pointing to it and the text "Enable or disable humidification" and "Deactivating will put the unit on standby". At the bottom is a blue navigation bar with a "Home" icon and a "More" icon. A line from the left points to the "Home" icon with the text "Go to home screen", and a line from the right points to the "More" icon with the text "Opens the menu".

* Absence of slider indicates an installed external humidity controller. Change the settings on the controller to change the setpoint.

6 Operation

6.1 General

Safety

Observe the following safety precautions as described in ["For Your Safety" on page 4](#).

6.2 Starting Up

IMPORTANT! Damaged or improperly installed units must NOT be operated. Damaged or improperly installed units may present a danger to persons and property.

To turn on the humidifier:

1. See the below instructions if you are starting the humidifier for the first time.
Press the power button for 2 seconds. The unit will turn on. The unit will begin humidification once it receives a demand for humidity.

6.3 Shutting Down

To turn off the humidifier:

1. Press and hold the power button for 2 seconds.

Should the unit be disconnected for an extended period of time, allow the humidifier to drain and shut down. After removing power from the humidifier, close the water supply valve.

6.4 Changing the Setpoint

Changing the setpoint of your HumiLife humidifier requires the Condair HumiLife app.

The ideal indoor humidity range is between 40% and 60%. To reach a particular humidity level, a setpoint (or desired humidity) is determined for the humidifier. If the humidity of your home is lower than the setpoint the humidifier will begin to humidify the air. It will continue to humidify until the humidity in your home reaches the setpoint.

To change the setpoint:

1. Open then Condair HumiLife app.
2. On the home screen, select your humidifier.
3. Move the humidity slider to your desired <%>.
4. Press the <Home> button to save your changes.

7 Maintenance

7.1 Maintenance

Replace the ceramic media every 2-3 years, at the beginning or end of the dry season (ex. winter), or when the Condair HumiLife app indicates.

Recommended: Clean the ceramic media at least once per dry season (minimum) and when the Condair HumiLife app indicates.

Ensure that the timers for replacement and cleaning are reset after maintenance.



CAUTION

The ceramic media is fragile and has sharp edges!

Please wear protective gloves when handling the ceramic media and treat it with care.

7.1.1 Replacing the Ceramic Media

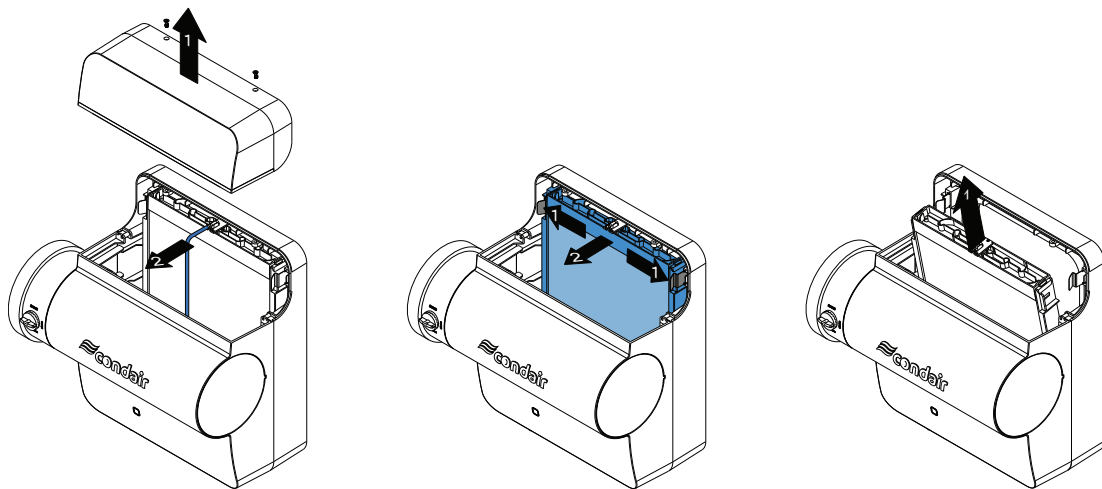

Figure 1 - Replacing the Ceramic Media

To replace the ceramic media:

1. Turn off the humidifier and shut off the water to the unit.
2. Remove the top cover of the humidifier. You should see a nozzle and hose for the water inside.
3. Disconnect the hose.
4. Pull apart the two tabs securing the ceramic media and tilt the ceramic media out.
5. Remove the ceramic media. The ceramic media can now be cleaned or replaced.
6. Push the ceramic media into the unit and secure with the tabs. Restore the water connection.
7. Reinstall the cover, then reset the maintenance timer in the Condair HumiLife app.

7.1.2 Cleaning the Ceramic Media

To clean the ceramic media:

1. Remove the ceramic media.
2. Clean the ceramic media:
 - a. Place the ceramic media (and plastic frame) through a dishwasher on a normal cycle.
 - b. If a dishwasher is not available or there is significant mineral buildup:
 - i. Fill a basin with a calcium-removing solution, ex. water (1 part) and vinegar (3 parts).
 - ii. Soak the ceramic media in the solution. Allow the solution to dissolve the mineral buildup.
 - iii. Rinse with clean water and repeat as necessary.
3. (Recommended) Wipe down the inside of the humidifier, especially near the base where the ceramic media sits.
4. Return the ceramic media to the humidifier, reattach the water hose to the ceramic media, and reinstall the covers.

8 Troubleshooting

Troubleshooting of the Condair HumiLife RE must only be performed by qualified and competent personnel. Electrical repairs must only be performed by a licensed electrician authorized by the customer, or by Condair service technicians.

Troubleshooting the Condair HumiLife RE may require the user to access the inside of the unit, to the control and plumbing cabinets, which may expose the user and equipment to hazards described in "[For Your Safety](#)" on page 4.

8.1 General Troubleshooting

Most operation warning and fault conditions are caused by improper installation, or by not adhering to the suggested best practices for installation of the humidifier and system components. Hence, a full fault diagnosis always requires a thorough examination of the entire system (hose connections, control systems, etc.).

General guidelines for troubleshooting are described below. For detailed troubleshooting of auxiliary system components, refer to their respective manuals.

The humidity at home is not increasing.

Probable Cause

- No power to the unit.
- Water supply is shut off.
- Ceramic media in the humidifier is not installed, or needs to be cleaned.
- Furnace fan is not on.
- Humidistat is not generating a demand.
- The security chain (air proving) is open or incorrectly installed.
- The room is too large, or there is cold air coming in.

Fix

- Close doors and windows.
- The room is too large. Contact Condair for further information.
- Check the humidistat. Ensure the setpoint value is higher than the actual reading. Ideal humidity between 40-60% RH.
- Check if the unit is turned on and there is water being supplied to the unit. Ensure there are no leaks.
- Check the ceramic media. Clean or replace the ceramic media, or contact Condair to check the unit.
- Turn on the furnace fan. Check the air proving (security loop, safety chain) is installed properly and wires are secured. Ensure the wires are connected properly on the control board on the humidifier. If this is defective, contact Condair.

There is condensation on the windows or walls (inside). The humidity at home is too high.

Probable Cause

- The humidity setpoint is too high.
- Improper ventilation (ex. furnace fan not working, or blockage).
- Window seals are leaking.
- Too many plants by the window.

Fix

- Check the humidistat. Ensure the setpoint value is lower than the actual reading. Ideal humidity between 40-60% RH.
- Check if the vents in your home are blocked, and free any obstructions.
- Check the furnace fan. It should be operating for the humidifier to work. If it is not running, check the air proving switch.
- Ensure the security loop (air proving or safety chain) is installed properly.
- Check the seals around the window. Reseal if necessary. Replace window panes if necessary.
- Move plants away from the window.
- Circulate air around the space.
- Use a moisture remover (ex. dehumidifier) in the room.
- Raise the indoor temperature.

The unit is not turning on.







Probable Cause





- The humidifier is not connected to the power supply.
- A fuse inside the humidifier has blown.

Fix

- Connect the humidifier to the power supply. Plug in the humidifier to the wall outlet.
- If the fuse on the humidifier control board is blown, contact Condair to check the unit.

8.2 Fault Indication

LED behavior	What does it mean?	Fix
 The power light is off	There is no power to the humidifier.	Ensure that the power cord is plugged into the wall socket. If it is off, check that the wires into the humidifier are not damaged, and is correctly inserted into the AC-in terminal of the driver board. Unplug the unit and open the bottom cover of the humidifier to access the driver board.
 The power light is blinking blue	The security loop is open.	Devices (ex. airflow switch, high-limit humidity switch) that ensure your humidifier stops running when there are issues with your ventilation system can trigger an open security loop. These devices are typically installed on your ducts and helps protect your home. The security loop (safety chain) must be closed in order for the humidifier to operate. Check the security loop devices. Ensure they are installed properly, and connected to the driver board in the humidifier. Check that air is moving through your duct system (ex. use a strip of paper or string at a vent). Ensure there are no obstructions. If the sensed humidity is greater than the high-limit setpoint (typically around 70% RH), reduce the setpoint on your Condair HumiLife app (or humidistat) and allow the humidity level to drop.
 The power light is fading	Unit is on standby mode.	(Blue) There is no demand for humidity. (Red) The humidifier was put on standby mode through the Condair HumiLife app. For example, the setpoint defined in the Condair HumiLife app is at 0.
 The WiFi light is off	There is no power to the humidifier.	Ensure that the power cord is plugged into the wall socket. If it is off, check that the wires into the humidifier are not damaged, and is correctly inserted into the AC-in terminal of the driver board. Unplug the unit and open the bottom cover of the humidifier to access the driver board.
 The WiFi light is blinking green	The humidifier is establishing a connection to phone (AP/Hotspot mode).	Wait to establish the connection. Check the network settings on your phone and connect to the network broadcast by the humidifier.
 The WiFi light is blinking blue	The humidifier is undergoing a software update.	Wait for the software to update.
 The WiFi light is red	The humidifier disconnected from the internet.	Check your home network settings, and try restarting the humidifier. Turn on the humidifier and press the power button for 5 seconds to enter AP mode. Use your phone to connect to the humidifier. Use the Condair HumiLife app to connect the humidifier to the internet by using your home network ID and password.

LED behavior	What does it mean?	Fix
 The WiFi is red and alert light is yellow	WiFi signal timeout. The humidifier is set up to receive a signal source from your WiFi, but does not detect a signal.	Check your WiFi settings and restart the humidifier. If the problem persists, and the humidifier still cannot connect to your WiFi network, contact us at www.condairhumilife.com .
 The media light is off	There is no power to the humidifier.	Ensure that the power cord is plugged into the wall socket. If it is off, check that the wires into the humidifier are not damaged, and is correctly inserted into the AC-in terminal of the driver board. Unplug the unit and open the bottom cover of the humidifier to access the driver board.
 The media and alert light is yellow	The ceramic media needs to be replaced soon.	The ceramic media is approaching the end of its life. Clean the ceramic media, or replace as necessary. After replacement, reset the system error by pressing and holding the power button for 3 seconds.
 The media and alert light is red	The ceramic media needs to be replaced.	The ceramic media has approached the end of its life and must be replaced. After replacement, reset the system error by pressing and holding the power button for 3 seconds.

LED behavior	What does it mean?	Fix
 The alert light is yellow	Control signal broken, or low control signal detected.	A control sensor input (ex. RH sensor, humidistat) is broken or not wired correctly. The humidifier will not operate until the sensor is fixed.
	Inlet valve fault or Internal sensors are not detecting humidity increase at the ceramic media.	<p>The inlet valve controls the flow rate of water that is allowed into the humidifier. Sensors placed inside the humidifier determine if there is water flowing through the ceramic media by checking the humidity and temperature before and after the ceramic material. If the humidifier software determines that it is activated for too long AND the sensors have similar readings, this warning appears. This warning may occur if the sensors are broken, or if the inlet valve is activated and no water is flowing through it.</p> <p>This warning goes away once the sensors detect a noticeable difference in humidity before and after the ceramic plate.</p> <p>Check the inlet valve and water supply line for any obstructions (ex. saddle valve did not puncture the water line, or the valve is shut off). Ensure the water supply line is open, and there is enough water flowing through to the humidifier.</p> <p>If the inlet valve is not working, seek a replacement. Contact us at www.condairhumilife.com.</p>
	Duct air temperature too low or Humidity in the air duct is too high.	<p>Check for and remove obstructions in the duct that may be causing the humidity in the duct to build up.</p> <p>Check if there is warm air flowing through the duct. If the air is too cold, there is a chance condensate will form in the duct, allowing mold to form. Ensure the furnace is on.</p>

Disclaimer

This Homeowners Manual provides basic product overview of the Condaire Humilife Humidifier (the "Humilife Humidifier") and is for general information purposes only. The general installation guidelines contained herein do not purport to cover all details of the Humilife Humidifier nor do they provide for every contingency met in connection with installation. Please consult the complete Installation Manual and Operation Manual for a more comprehensive installation guide and for general operation, maintenance, and troubleshooting information, including Condaire's suggested storage, packaging, and transportation guidelines. The Installation Manual and Operation Manual contain specific system, accessories, and components. Copies of the complete Installation Manual and Operation Manual can be found at: www.condairhumilife.com. Please read all Cautions and Warnings before installing and using the Humilife Humidifier.

All electrical connections must be installed in accordance with local and national electrical code requirements by a licensed electrician.

All water supply and drain line connections must be installed in accordance with local plumbing codes by a licensed plumber.

Condaire does not accept any liability for installations of humidity equipment installed by unqualified personnel or the use of parts/components/equipment that are not authorized or approved by Condaire.

Compliance

This equipment has been tested and found to comply with the limits for a Class B digital device, pursuant to part 15 of the FCC Rules. These limits are designed to provide reasonable protection against harmful interference in a residential installation. This equipment generates, uses and can radiate radio frequency energy and, if not installed and used in accordance with the instructions, may cause harmful interference to radio communications. However, there is no guarantee that interference will not occur in a particular installation.

If this equipment does cause harmful interference to radio or television reception, which can be determined by turning the equipment off and on, the user is encouraged to try to correct the interference by one or more of the following measures:

- Reorient or relocate the receiving antenna.
- Increase the separation between the equipment and receiver.
- Connect the equipment into an outlet on a circuit different from that to which the receiver is connected.
- Consult the dealer or an experienced radio/TV technician for help.

Warranty

Condaire Inc. and/or Condaire Ltd. (hereinafter collectively referred to as THE COMPANY), warrant for a period of five years from the date of purchase by the customer, that THE COMPANY's manufactured and assembled products, not otherwise expressly warranted, are free from defects in material and workmanship. No warranty is made against corrosion, deterioration, or suitability of substituted materials used as a result of compliance with government regulations.

THE COMPANY's obligations and liabilities under this warranty are limited to furnishing replacement parts to the customer, F.O.B. THE COMPANY's factory, providing the defective part(s) is returned freight prepaid by the customer. Parts used for repairs are warranted for the balance of the term of the warranty on the original humidifier or 90 days, whichever is longer.

The warranties set forth herein are in lieu of all other warranties expressed or implied by law. No liability whatsoever shall be attached to THE COMPANY until said products have been paid for in full and then said liability shall be limited to the original purchase price for the product. Any further warranty must be in writing, signed by an officer of THE COMPANY.

THE COMPANY's parts or materials that are considered consumables, including but not limited to: cylinders, filters, nozzles, membranes, media, gaskets, O-rings, etc. are NOT covered by the warranty.

THE COMPANY makes no warranty and assumes no liability unless the equipment is installed in strict accordance with a copy of the catalog and installation manual in effect at the date of purchase and by a contractor approved by THE COMPANY to install such equipment.

THE COMPANY makes no warranty and assumes no liability whatsoever for consequential damage or damage resulting directly from misapplication, incorrect sizing or lack of proper maintenance of the equipment.

THE COMPANY makes no warranty and assumes no liability whatsoever for damage resulting from freezing of the humidifier, supply lines, drain lines, or quality of the water used.

THE COMPANY retains the right to change the design, specification and performance criteria of its products without notice or obligation.

THE COMPANY's limited warranty on accessories, not of the company's manufacture, such as controls, humidistats, pumps, etc. is limited to the warranty of the original equipment manufacturer from date of original shipment of humidifier.

CANADA

2740 Fenton Road
Ottawa, ON, K1T 3T7

Tel: 1.866.667.8321
Fax: 613.822.7964
na.humilife@condair.com
www.condair.com
www.condairhumilife.com

