

Submittal Sheet

Condair HumiLife – The Flexible Room Solution Condair MN Series



- Hygienic, whole-home, adiabatic, atomizing humidification system.
- Standalone system does not require central duct work or any other specific type of heating.
- Head programming capabilities for individual zone humidity control.
- Remote control and monitoring through a convenient user mobile app.
- Low energy consumption.
- Cloud based monitoring system for continuous optimization and rapid fault detection.
- Integral, high precision humidity sensors at each humidification head for accurate ambient humidity control.
- Aesthetic head design to blend almost invisibly into the room.
- Recessed or surface mounted heads for different types of ceiling or wall construction.
- Optional packaged RO system to pre-treat supply water for maximum filter life.
- UL listed.

Product Overview

Condair HumiLife – The Flexible Room Solution is a completely unique, standalone residential humidification system. The Flexible Room Solution is engineered and specified to suit each individual application. This system consists of a central unit which is mounted in a mechanical space with access to water, drain, power and a LAN internet connection. This central unit is connected to individual, aesthetic humidification heads which are mounted almost invisibly into the humidified rooms of the house. The humidification heads silently add water with the highest level of hygiene to the ambient air within the home. The humidification heads are connected to the central unit by ‘spray loops’, which feed water and low voltage power to each of the heads. This humidifier will maintain the optimal 40-60% RH across all occupied rooms of the home, which is critical for your health, comfort and preservation of valuable investments.

The Flexible Room Solution has four main configurations for application flexibility:

- Central unit + 1 filter unit, 1 spray loop.
- Central unit + 1 filter unit, 2 spray loops.
- Central unit + 2 filter units, 1 spray loop.
- Central unit + 2 filter units, 2 spray loops.

Each spray loop can feed a maximum of 10 humidification heads, so the maximum number of heads per central unit system is 20 – 10 heads on each of the two spray loops.

Technical Specifications

Central Unit:

	1 Filter 1 Spray Loop	1 Filter 2 Spray Loops	2 Filters 1 Spray Loop	2 Filters 2 Spray Loops
Central Unit Dimensions W x H x D	19.9" x 22.6" x 9.8" (505 mm x 575 mm x 250 mm)		27.95" x 22.64" x 9.84" (710 mm x 575 mm x 250 mm)	
Minimum Installation Space Required	21.65" x 24.60" x 10.63" (550 mm x 625 mm x 270 mm)		29.72" x 24.60" x 10.63" (755 mm x 625 mm x 270 mm)	
Operational Weight of Central Unit + Filters	61.1 lbs (27.7 kg)		90.4 lbs (41 kg)	
Water Supply Connection	3/4" NPT			
Approximate Water Flush Volume	5.3 gal/day (20 L/day)		6.3 gal/day (24 L/day)	
Permissible Water Pressure Range	43.5 – 72.5 psig (300 – 500 kPa)			
Permissible Water Temperature Range	41 – 77 °F (5 – 25 °C)			
Permissible Water Conductivity	5 – 1000 µS/cm			
Permissible Water Hardness	50 – 530 ppm (2.9 – 30.1 gpg)			
Water Treatment	Disposable mixed-bed filter and optional RO system			
UV Lamp	For water sterilization			
Central Unit Electrical Connection	115 VAC / 60 Hz (shipped with power cord for a standard wall socket)			
Operating Voltage	24 – 36 VDC			
Max. Current Draw	1.2 A	1.6 A	1.2 A	1.6 A
Max. Power Consumption	45 W	60 W	45 W	60 W
Housing Construction	Galvanized sheet steel, powder coated			
Housing IP Protection	IP 20			
Permissible Ambient Room Temp.	41 – 77 °F (5 – 25 °C)			
Touchscreen Control (central unit)	3 humidity levels, humidity off, operating status, fault indicator, filter change			
Mobile User Control	Condair WEB application			

Humidification Heads:

Humidifying Output (per humidification head)	1.27 gal/day / 10.6 lbs/day / 4.8 kg/day (±10%)	
Nominal Operating Voltage	36 VDC	
Nominal Power Consumption	30 mA	
Sound Pressure Level	< 25 dB(A) (in accordance with SIA 181)	
Dimensions, flush/recessed mounting		
Humidifier unit diameter 2.87" (73 mm)	Humidifier unit diameter 2.87" (73 mm)	
Panel diameter 4.13" (105 mm)	Panel diameter 4.13" (105 mm)	
Humidifier unit height (including panel) 2.05" (52 mm)	Humidifier unit height (including panel) 2.05" (52 mm)	
Min. installation depth 3.94" (100 mm)	Min. installation depth 3.94" (100 mm)	
Panel height 0.47" (12 mm)	Panel height 0.47" (12 mm)	
Dimensions, "round" surface mounting		
Humidifier unit diameter 2.87" (73 mm)	Humidifier unit diameter 2.87" (73 mm)	
Panel diameter 3.43" (87 mm)	Panel diameter 3.43" (87 mm)	
Humidifier unit height (including panel) 2.68" (68 mm)	Humidifier unit height (including panel) 2.68" (68 mm)	
Dimensions, "square" surface mounting		
Humidifier unit diameter 2.87" (73 mm)	Humidifier unit diameter 2.87" (73 mm)	
Panel dimensions 3.43" x 3.43" (87 x 87 mm)	Panel dimensions 3.43" x 3.43" (87 x 87 mm)	
Humidifier unit height (including panel) 2.76" (70 mm)	Humidifier unit height (including panel) 2.76" (70 mm)	

Spray Loop:

Spray Loop Water Hose	
Material	John Guest "PE-04025-0100M-N"
Diameter (ID/OD)	0.16" / 0.24" (4 / 6 mm)
Spray Loop Electrical Cable (CAN Bus)	
Type	2 x 2 twisted pair
Diameter (OD)	0.31" (8mm)
Line Impedance	120 ohms
Spray Loop Guide Pipe/Conduit	
Material	KRFG pipe (electric metallic conduit recommended when running conduit through ceiling or air plenum)
Diameter	1" (25mm)

Spray Loop Length:

Water Supply Pressure	Max. Spray Loop Length (per spray loop)
43.5 psig (300 kPa)	up to 197 ft (60 m)
50.8 psig (350 kPa)	up to 262 ft (80 m)
58.0 psig (400 kPa)	up to 328 ft (100 m)
65.3 psig (450 kPa)	up to 361 ft (110 m)
72.5 psig (500 kPa)	up to 394 ft (120 m)

Note:

The permissible water pressure range is between 43.5 PSI (3 Bar) - 72.5 PSI (5 Bar). You lose 14.5 PSI (1 Bar) for every 32.8 feet (10 M) in height. Our systems include an RO-HB which have a Pressure Tank and a Pressure Booster Module.

Installation

System Overview – Central Spray Loop Termination:

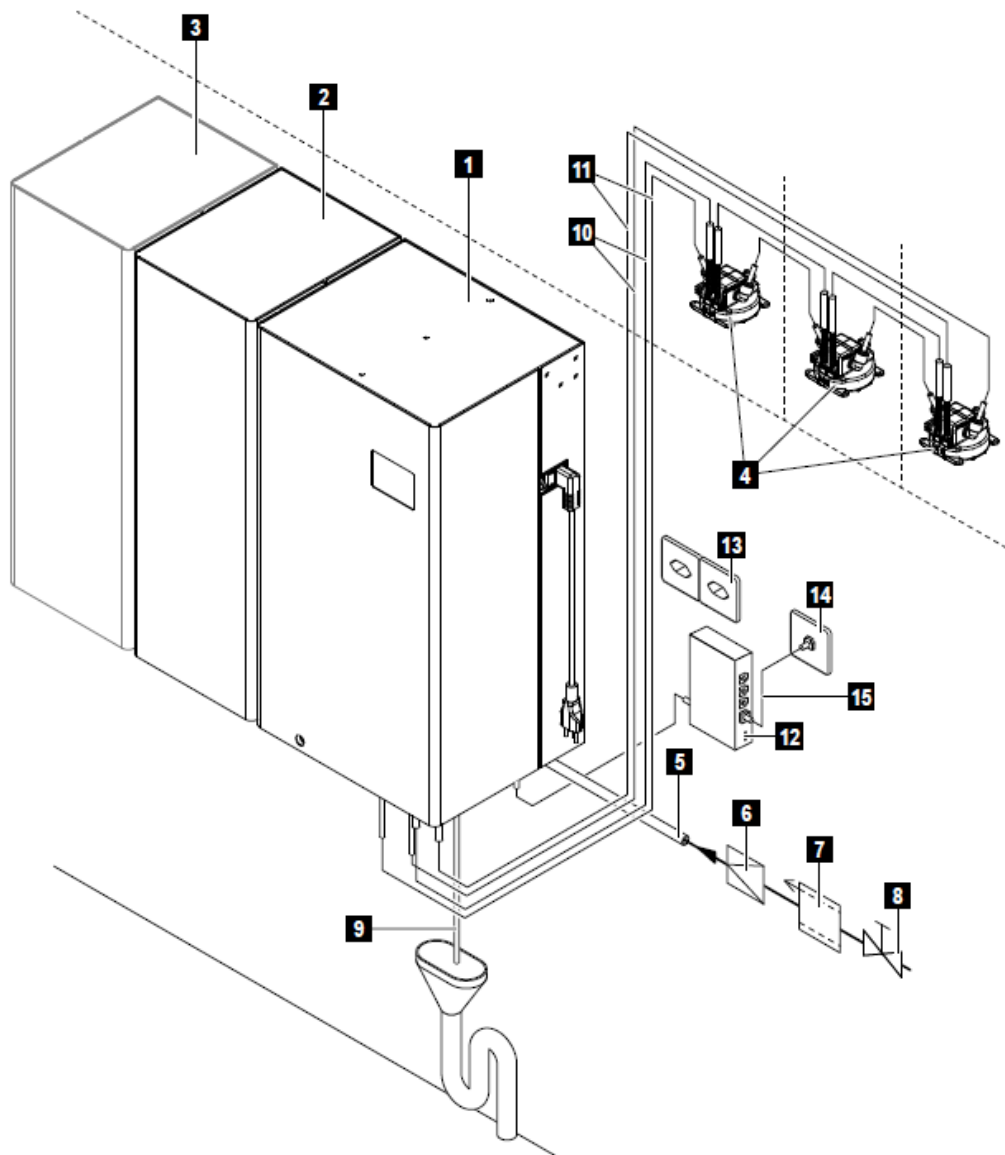

- | | | | |
|---|--|----|---|
| 1 | Central unit with integrated drainage modules | 9 | Central unit water outlet |
| 2 | Water filter in housing | 10 | CAN bus cable |
| 3 | Optional second water filter in housing | 11 | Hoses |
| 4 | Humidifier units | 12 | LAN gateway |
| 5 | Water feed line (provided on site, last 19.7" (50 cm) with reinforced hose) | 13 | Mains power sockets for central unit and LAN gateway (provided on site) |
| 6 | Pressure reduction valve (provided on site) for water pressures >14.5 psig (>500 kPa) | 14 | LAN connection (provided on site) |
| 7 | Backflow preventer for fluid category 2 with integrated particle filter (provided on site) | 15 | LAN cable (provided on site) |
| 8 | Water inlet shut-off valve (provided on site) | | |

System Overview – External Spray Loop Termination:

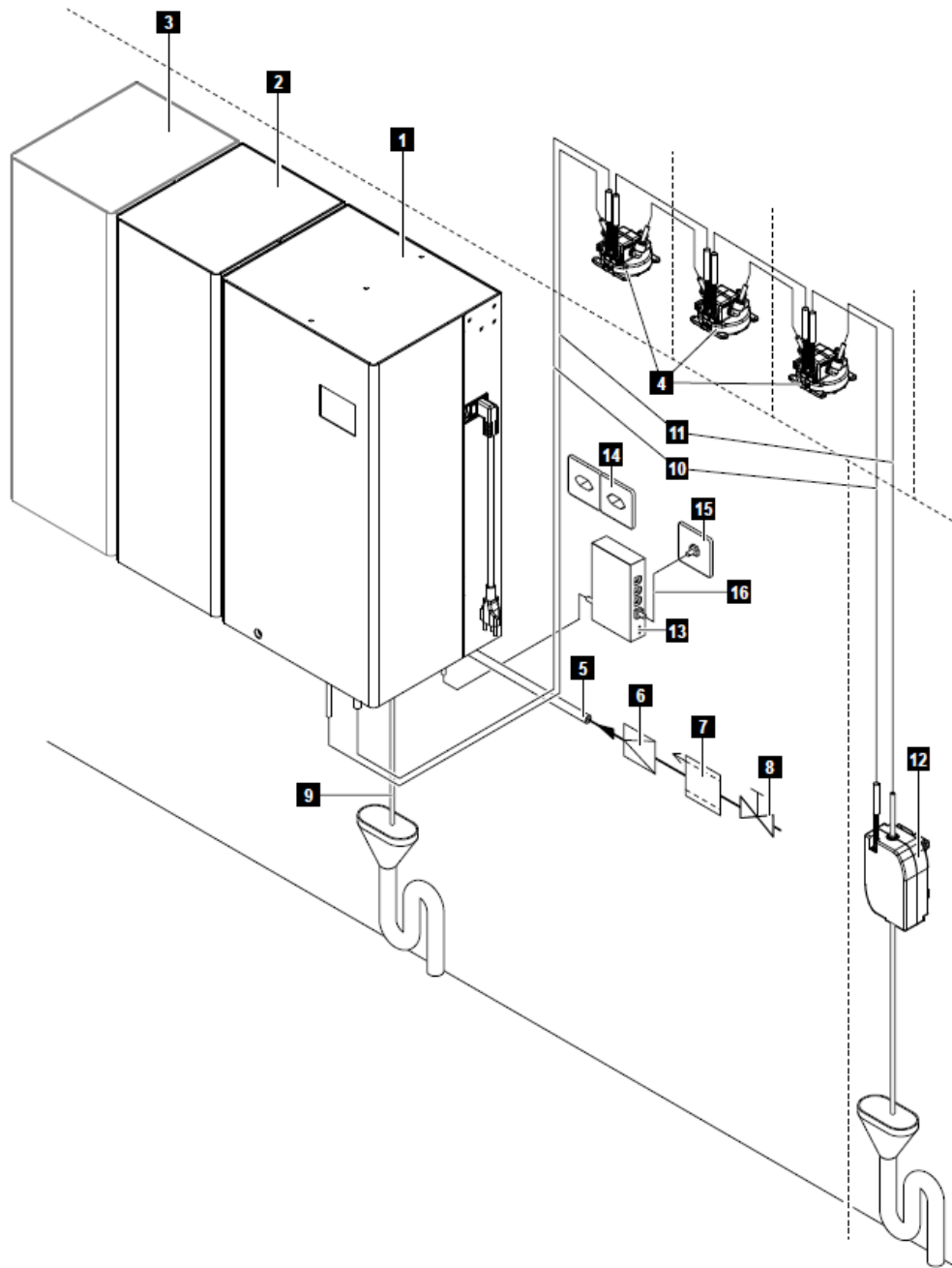

- | | | | |
|---|---|----|---|
| 1 | Central unit with integrated drainage modules | 9 | Central unit water outlet |
| 2 | Water filter in housing | 10 | CAN bus cable |
| 3 | Optional second water filter in housing | 11 | Hoses |
| 4 | Humidifier units | 12 | Drainage module (installed externally) |
| 5 | Water feed line (provided on site, last 19.7" (50 cm) with reinforced hose) | 13 | LAN gateway |
| 6 | Pressure reduction valve (provided on site) for water pressures >14.5 psig (>500 kPa) | 14 | Mains power sockets for central unit and LAN gateway (provided on site) |

- 7 Backflow preventer for fluid category 2 with integrated particle filter (provided on site)
- 8 Water inlet shut-off valve (provided on site)

- 15 LAN connection (provided on site)
- 16 LAN cable (provided on site)

Schematics

Central Unit:

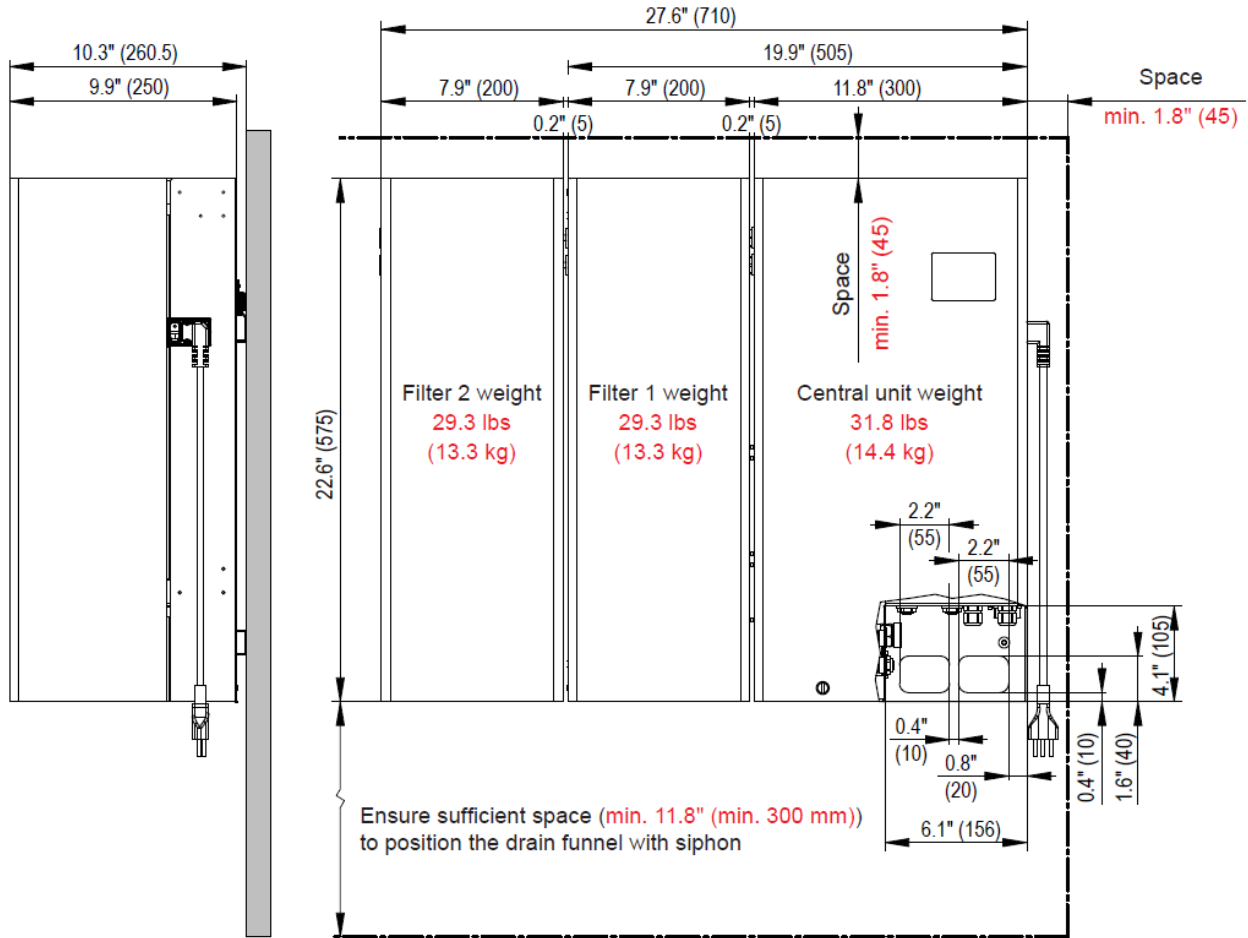

Humidification Head Positioning:

A	Min. horizontal distance from obstacles in humidifier unit wall installation 39.4" (1.0 m)
B	Min. distance of surface-installed humidifier units from the ceiling 3.9" (0.1 m)
C	Min. space "C" beneath the humidifier unit 59.1" (1.5 m)
D	Min. distance "D" from windows in humidifier unit ceiling installation 39.4" (1.0 m)
E	Min. distance "E" from walls in humidifier unit ceiling installation 19.7" (0.5 m)

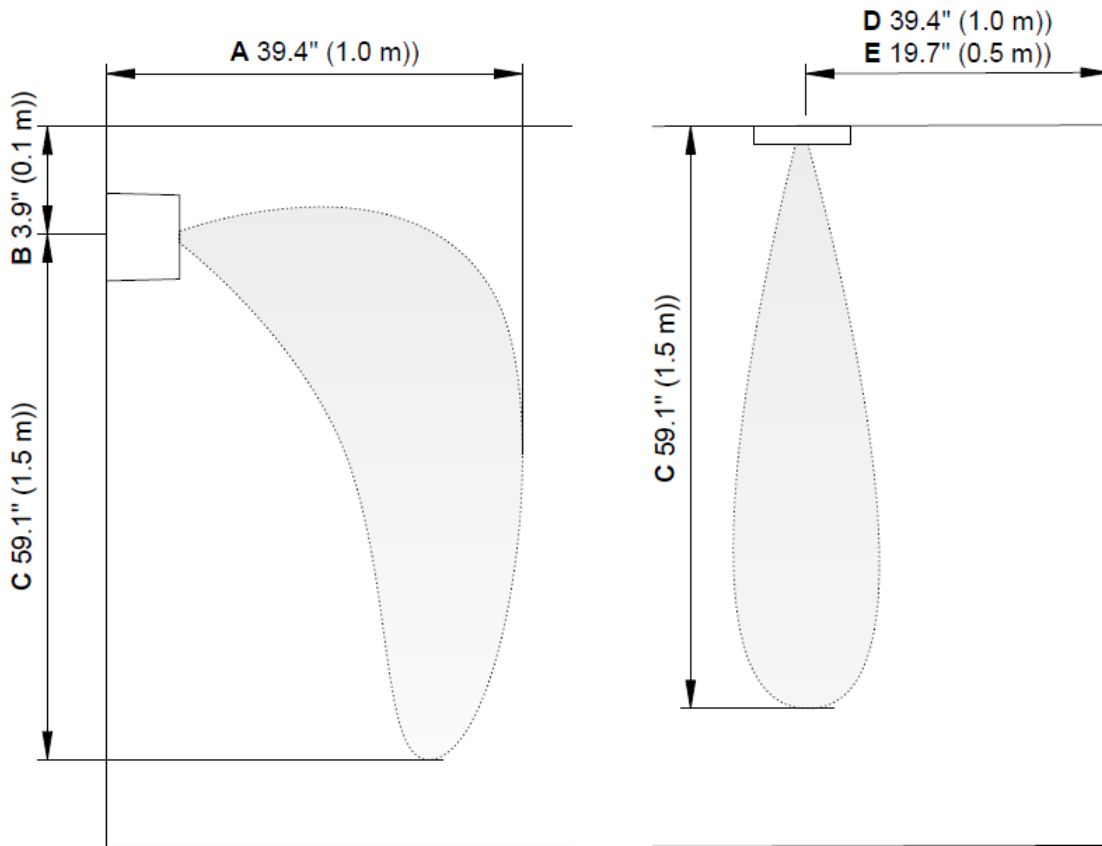

Typical Spray Loop Design:

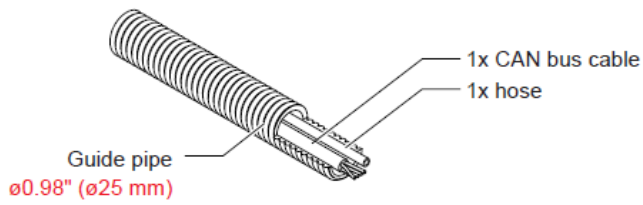
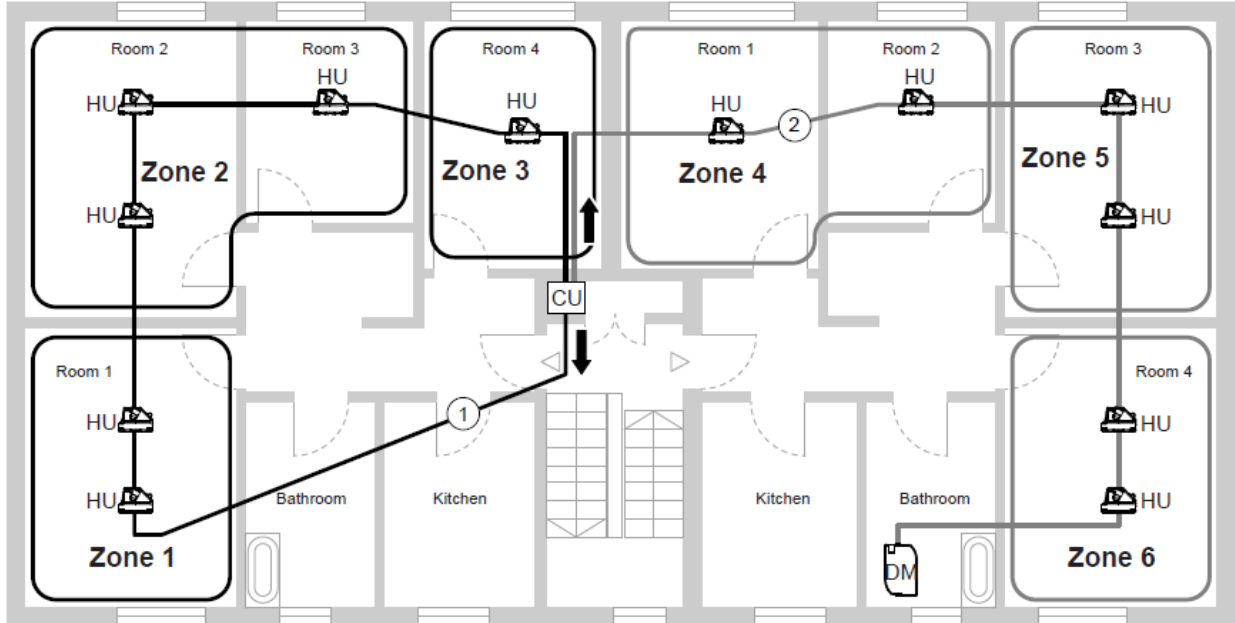

- CU: Central unit
- HU: Humidifier unit
- DM: Drainage module (peripheral drainage)
- 1: Spray circuit with central drainage
- 2: Spray circuit with peripheral drainage