

Condair DL

ERSATZTEILE / SPARE PARTS / PIECES DE RECHANGE

Änderungen vorbehalten! / Subject to change! / Modifications réservées!

Pos	Artikel/Article/Article	Zusatz / Completion / Complément	Art.-/SAP-No.
Zentraleinheit / Central unit / Unité centrale			
101	Einlass Magnetventil 24VDC Inlet solenoid valve 24VDC Vanne d'admission 24VDC		2579725
102	Leitwertelektrode Conductivity electrode Electrode de conductivité		1105386
103	O-Ring O-ring Joint torique		2579726
104	Drucksensor (2 Stk.) Pressure sensor (2 pcs) Senseur pression (2 pcs)		2579727
105	O-Ring (2 Stk.) O-ring (2 pcs) Joint torique (2 pcs)		2579728
106	Manometer Manometer Manomètre		1116201
107	Einschraubstutzen (2 Stk.) Stem adapter (2 pcs) Douille de jonction (2 pcs)	Ø 12 mm - 3/8"	2579729
108	L-Einsteckverbinder (5 Stk.) Stem L-connector (5 pcs) Raccord tige coudé (5 pcs)	Ø 12 mm	1118793
109	Einschraubverbinder NIRO (1 Stk.) Male connector stainless steel (1 pcs) Union simple mâle INOX (1 pcs)	Ø 12 mm - 3/8"	2579730
110	L-Verbinder (5 Stk.) L-connector (5 pcs) Raccord coudé (5 pcs)	Ø 12 mm	1118795
112	Wasserfilter komplett Water filter complete Filtre d'eau complete		2579731
113	O-Ring Wasserfilter O-ring water filter Joint torique filtre d'eau		2579688
114	Filtereinsatz Water filter Filtre d'eau		2579689
115	Set Silberionisierung Hygiene Plus Set silver ionisation Hygiene Plus Set ionisation argent Hygiène Plus	Typ / Type / Type 30 Typ / Type / Type 60 Typ / Type / Type 125 Typ / Type / Type 250 Typ / Type / Type 500	2602477 2602478 2602479 2602480 2602481
116	Schottverbinder (4 Stk.) Bulkhead connector (4 pcs) Traversée par cloison (4 pcs)	Ø 10 mm - 1/2"	1118934

Pos	Artikel/Article/Article	Zusatz / Completion / Complément	Art.-/SAP-No.
117	Schottverbinder Bulkhead connector Traversée par cloison	Ø 12 mm - 3/4"	1118935
118	L-Einsteckverbinder (5 Stk.) Stem L-connector (5 pcs) Raccord tige coudé (5 pcs)	Ø 10 mm	2533070
119	Wandhalterung Wall support Porte mural		2579690
120	Wasserstrahlpumpe komplett Ejector pump complete Éjecteur à eau complete		2579691
121	Verbindungsleitung Wasserstrahlpumpe Connection ejector pump Joncteur éjecteur à eau		2579692
122	Ventilblock komplett Valve block complete Bloc de vanne complète	3 Sprüh-Ventile / spray valve / vanne d'atomisation 4 Sprüh-Ventile / spray valve / vanne d'atomisation 5 Sprüh-Ventile / spray valve / vanne d'atomisation 6 Sprüh-Ventile / spray valve / vanne d'atomisation	2579693 2579973 2579974 2594723
123	Ventilblock Oberteil Valve block upper component Bloc de vanne partie supérieure	3 Sprüh-Ventile / spray valve / vanne d'atomisation 4 Sprüh-Ventile / spray valve / vanne d'atomisation 5 Sprüh-Ventile / spray valve / vanne d'atomisation 6 Sprüh-Ventile / spray valve / vanne d'atomisation	2579697 2579975 2579976 2594724
124	Ventilblock Unterteil Valve block bottom part Bloc de vanne embase	3 Sprüh-Ventile / spray valve / vanne d'atomisation 4 Sprüh-Ventile / spray valve / vanne d'atomisation 5 Sprüh-Ventile / spray valve / vanne d'atomisation 6 Sprüh-Ventile / spray valve / vanne d'atomisation	2579698 2579977 2579978 2594726
125	Magnetspule Coil drain valve Electro-aimant vanne		2578825
—	Verbindungskabel Magnetspule für 2594723 Connection cable solenoid coil for 2594723 Câble de connexion électro-aimant pour 2594723		2594727
127	Einschraubverbinder NIRO (5 Stk.) Male connector stainless steel (5 pcs) Union simple mâle INOX (5 pcs)	Ø 6 mm - 1/8"	2556816
128	L-Verbinder (5 Stk.) L-connector (5 pcs) Raccord coudé (5 pcs)	Ø 6 mm	1120279
129	L-Verbinder (5 Stk.) L-connector (5 pcs) Raccord coudé (5 pcs)	Ø 10 mm	1119785
130	Schlauch EPDM Hose EPDM Tuyau EPDM	Ø 12 mm	2579905
131	PA-Rohr PA tube Tuyau PA	Ø 12 mm, L = 3 m	2579700
132	Wasseranschluss-Set Water connection kit Set de connexion entrée d'eau		2579701
133	Einschraubverbinder NIRO (5 Stk.) Male connector stainless steel (5 pcs) Union simple mâle INOX (5 pcs)	Ø 8mm 1/8"	2580110
134	Stopfen (4 Stk.) Plug (4 pcs) Bouchon (4 pcs)		2579702
135	T-Verbinder (5 Stk.) T-connector (5 pcs) Raccord-T (5 pcs)	Ø 12 mm	1118792

Pos	Artikel/Article/Article	Zusatz / Completion / Complément	Art.-/SAP-No.
136	L-Einsteckverbinder (5 Stk.) Stem L-connector (5 pcs) Raccord tige L (5 pcs)	Ø 6 mm	1116174
137	Wasserablauf-Set Water drain kit Set de connexion sortie d'eau		2583655
138	Frontabdeckung Zentraleinheit Front cover central unit Face avant unité centrale		2581464
139	Block Manometer, inklusive Verschraubung und O-Ringe Block manometer, fitting and O-rings included Bloc manomètre, avec vissage et joint toriques		2591855
140	Block Sensor Düsendruck, inklusive Verschraubung und O-Ring Block sensor nozzle pressure, fitting and O-ring included Bloc senseur pression, avec vissage et joint torique		2591856
141	Block Druckschalter, inklusive Verschraubung und O-Ring Block pressure switch, fitting and O-ring included Bloc mancontacteur à pression, avec vissage et joint torique		2591857
201	Drehschieberpumpe Rotary vane pump Pompe à tiroirs rotatifs	73 l/h @ 2300 1/min 170 l/h @ 2300 1/min 390 l/h @ 2300 1/min 925 l/h @ 2300 1/min 1167 l/h @ 2300 1/min	2579706 2579707 2579708 2579709 2579710
202	Pumpenmotor Pump motor Moteur pompe	0.37 kW 0 - 170 l/h 0.55 kW >170 l/h - 390 l/h 0.75 kW >390 l/h - 1167 l/h	2579711 2579712 2579713
203	Befestigung Pumpe Pump support Fixage pompe		2579714
204	Druckschalter Pressure switch Manocontacteur à pression		1116199
205	Rückschlagventil Check valve Soupape de retenue	Ø12	2579716
206	Einschraub-Verbinder (1 Stk.) Screw-type connector (1 pcs) Raccord vissé (1 pcs)	Ø12 - 3/8" (≤ 390 l/h) Ø12 - 1/2" (> 390l/h)	2580111 2580112
207	Adapter Pumpe Adapter pump Adaptateur pompe		2579717
208	Nabe Boss Moyeau	≤ 170 l/h > 170 l/h	2579718 2579719
209	O-Ring O-ring Joint torique		2579720
210	Ringschlüssel für Wasserfilter Ring wrench for water filter Clé polygonale pour filtre d'eau		2584810
—	Kabelbaum Zentraleinheit Cable tree central unit Faisceau de câbles unité centrale	1 Meter / mit Pumpe / with pump / avec pompe 1 Meter / ohne Pumpe / without pump / sans pompe 5 Meter / mit Pumpe / with pump / avec pompe 5 Meter / ohne Pumpe / without pump / sans pompe	2580605 2580606 2580607 2580608
—	Kabelbaum Zentraleinheit inkl. Drossel Cable tree central unit incl. reactor Faisceau de câbles unité centrale incl. inductance d'arrêt	10 Meter / mit Pumpe / with pump / avec pompe 10 Meter / ohne Pumpe / without pump / sans pompe	2580609 2580610

Pos	Artikel/Article/Article	Zusatz / Completion / Complément	Art.-/SAP-No.
Steuereinheit / Control unit / Unité de commande			
301	Leistungsteil Driverboard Platine de puissance		2579733
302	Lf Board Conductivity Board Platine de conductivité		2579734
303	Silber Ionisierungsprint Silver ionization board Platine ionisation argent		2579735
304	Betriebs- und Störungsfernmeldung Remote operating and fault indication Télésignalisation d'exploitation et de dérangement		2579736
305	Integrated controller mit Touchpanel Integrated controller with touchpanel Integrated controller avec touchpanel		2579737
309	Frequenzumrichter Frequency converter Convertisseur de fréquence	für Motor/for motor/pour moteur 0.37 kW für Motor/for motor/pour moteur 0.55 kW für Motor/for motor/pour moteur 0.75 kW	2580630 2580629 2579738
310	Leckage Melder Leak indicator Indicateur de fuite		2566935
311	Stecksockel für Leckagemelder Base leak indicator Socle indicateur de fuite		2553226
312	Netzfilter Line Filter Filtre d'alimentation		2579739
313	Kabelverschraubung EMV NIRO Cable cland EMC stainless steel Presse-étoupe CEM INOX	M20 x 1.5	2579740
314	Kabeleinführungsleiste Cable entry frames Passage de câble		2579741
315	Schalter Switch Interrupteur		2579742
316	Kabelverschraubung (5 Stk.) Cable cland (5 pcs) Presse-étoupe (5 pcs)	M20 x 1.5	2579743
317	Ferritring teilbar Snap Ferrite Ferrites à clapet		2579744
318	Netzteil Power supply Alimentation électrique		2579745
320	Anschlussklemmen L N 2xPE Connecting terminal L N 2xPE Borne de connection L N 2xPE		2579746
321	Schliessbolzen komplett Cotter pin complete Bouton de fermeture		2579747
322	Verdrahtungskanal Cable conduit Conduit de câbles	L = 150 mm	2579748
323	Verdrahtungskanal Cable conduit Conduit de câbles	L = 300 mm	2579749
324	Drossel Reactor coil Inductance d'arrêt	Nur bei verlängertem Kabelbaum mit Pumpe Only by extended cable tree avec pump Seul. pour faisceau de câbles prolongée avec pomps	2579750

Pos	Artikel/Article/Article	Zusatz / Completion / Complément	Art.-/SAP-No.
325	Frontabdeckung Steuereinheit Front cover control unit Face avant unité de commande		2584468
—	Kabelbaum Steuereinheit Cable tree control unit Faisceau de câbles unité de commande		2580627
—	Lecksensor Leak sensor Senseur de fuite		2580638
—	Sensorkabel Lecküberwachung Cable sensor leak monitoring Câble de surveillance des fuites	1.5 m 3.0 m 13.0 m	2595349 2595350 2595348
—	Smart Card Smart Card Smart Card		2584599

Düsensystem / Nozzle system / Système des buses

401	Düse mit O-Ring (3 Stk.) Nozzle with O-ring (3 pcs) Buse avec joint torique (3 pcs)	1.5 l/h 2.0 l/h 2.5 l/h 3.0 l/h 3.5 l/h 4.0 l/h 4.5 l/h 5.0 l/h	2579752 2594363 2579754 2579756 2594364 2579757 2594365 2579759
402	O-Ringe Düse (2x 20 Stk.) O-rings nozzle (2x 20 pcs) Joint torique buse (2x 20 pcs)	aussen+innen / outside+inside / extérieur+intérieur	2577916
403	Düsenhalter (2 Stk.) Nozzle support (2 pcs) Support pour buse (2 pcs)		2579764
404	L-Verbinder (5 Stk.) L-connector (5 pcs) Raccord coudé (5 pcs)	ø 8 mm	1118794
405	T-Verbinder (5 Stk.) T-connector (5 pcs) Raccord-T (5 pcs)	ø 8 mm	1118752
406	Set Kennzeichnungshülsen (10 Stk.) Set designation bushings (10 pcs) Set cosse de codification (10 pcs)	rot / red / rouge blau / blue / bleue gelb / yellow / jaune grün / green / verte	1117730 1117731 1117732 2579699
407	Haltebügel (4 Stk.) Holder (4 pcs) Etrier de blocage (4 pcs)		2579766
408	Befestigungsplatte (2 Stk.) Mounting plate (2 pcs) Plateau de fixation (2 pcs)		2579769
409	Versteifungsplatte (2 Stk.) Reinforcement plate (2 pcs) Plateau de renforcement (2 pcs)		2579771
410	Wanddurchführung Wall lead through Passage de boîtier	L = 75 mm L = 125 mm	1118875 2557823
411	Dichtung Wanddurchführung (3 Stk.) Gasket wall lead through (3 pcs) Joint passage de boîtier (3 pcs)		2579774
412	PA-Schlauch (pro Meter) PA tube (per meter) Tuyau PA (par mètre)	ø 10 mm	1117738
413	PA-Schlauch (pro Meter) PA tube (per meter) Tuyau PA (par mètre)	ø 8 mm	1102840

Pos	Artikel/Article/Article	Zusatz / Completion / Complément	Art.-/SAP-No.
414	L-Einschraubverbinder (5 Stk.) Screw-type L-connector (5 pcs) Raccord vissé L (5 pcs)	ø 8 mm - 1/4"	1116173
	L-Einschraubverbinder NIRO (1 Stk.) Screw-type L-connector stainless steel (1 pcs) Raccord vissé L INOX (1 pcs)	ø 8 mm - 1/4"	2556818
415	L-Einschraubverbinder (5 Stk.) Screw-type L-connector (5 pcs) Raccord vissé L (5 pcs)	ø 10 mm - 1/4"	1118162
	L-Einschraubverbinder NIRO (1 Stk.) Screw-type L-connector stainless steel (1 pcs) Raccord vissé L INOX (1 pcs)	ø 10 mm - 1/4"	2556819

Nachverdunstereinheit / Post evaporation unit / Unité posthumidification

501	Keramikplatte links Ceramic plate left Plaque de céramique à gauche	200 x 250 mm	2578830
		250 x 250 mm	2578831
		200 x 300 mm	2578832
		250 x 300 mm	2578833
		200 x 410 mm	2578834
502	Keramikplatte rechts Ceramic plate right Plaque de céramique à droite	250 x 410 mm	2578835
		200 x 250 mm	2578836
		300 x 250 mm	2578837
		400 x 250 mm	2578838
		200 x 300 mm	2578839
503	Keramikplatte mitte Ceramic plate middle Plaque de céramique centre	300 x 300 mm	2578840
		300 x 300 mm	2578841
		200 x 410 mm	2578842
		300 x 410 mm	2578843
		400 x 410 mm	2578844
		300 x 250 mm	2578845
		500 x 250 mm	2578846
504	Abdichtblech seitlich Sealing plate lateral Tôles d'étanchéité latéral	300 x 300 mm	2578847
		500 x 300 mm	2578848
		300 x 410 mm	2578849
		500 x 410 mm	2578850
		700 x 300 mm	2578853
505	Befestigungsprofil Abdichtung seitlich Mounting bracket sealing lateral Equerre tôles d'étanchéité latéral	700 x 410 mm	2578854
		L = 325 mm	2579776
		L = 650 mm	2579777
		L = 990 mm	2579778
		L = 150 mm	2590387
506	Abdichtblech oben Sealing plate top Tôles d'étanchéité au-dessus	L = 250 mm	2590388
		L = 400 mm	2579780
		L = 500 mm	2579782
		L = 600 mm	2579787
		L = 700 mm	2579788
		L = 1000 mm	2579789
507	Befestigungsprofil Decke Fastening profile top Tôle de fixation plafond	L = 300 mm	2579790
		L = 600 mm	2579791
508	Haltebügel Keramikträger (2 Stk.) Holder ceramic carrier (2 pcs) Etrier de blocage céramique (2 pcs)	L = 250 mm	2579792
		L = 660 mm	2579793
		links + rechts left + right à gauche + à droite	2579794

Pos	Artikel/Article/Article	Zusatz / Completion / Complément	Art.-/SAP-No.
509	Keramik Trägerprofil Ceramic carrier profile Support céramique	L = 375 mm L = 450 mm L = 525 mm L = 600 mm L = 675 mm L = 750 mm L = 825 mm L = 900 mm L = 975 mm L = 1050 mm L = 1125 mm L = 1200 mm L = 1275 mm L = 1350 mm L = 1425 mm L = 1500 mm L = 1610 mm L = 1720 mm L = 1830 mm L = 1940 mm	2583540 2579795 2583541 2579796 2583542 2579797 2583543 2579798 2583544 2579799 2583545 2579800 2583546 2579801 2583547 2579802 2583548 2583549 2583550 2583551
510	Halterung (2 Stk.) Support (2 pcs) Support (2 pcs)		2579803
511	Gummidichtung unten (pro Meter) Bottom rubber sealing (per meter) Joint en caoutchouc en bas (par mètre)	H = 200 mm H = 300 mm H = 450 mm	2577314 1119940 2519747
512	Keramik Abstützprofil Ceramic support profile Cale pour céramic	L = 375 mm L = 450 mm L = 525 mm L = 600 mm L = 675 mm L = 750 mm L = 825 mm L = 900 mm L = 975 mm L = 1050 mm L = 1125 mm L = 1200 mm L = 1275 mm L = 1350 mm L = 1425 mm L = 1500 mm L = 1610 mm L = 1720 mm L = 1830 mm L = 1940 mm	2583552 2579804 2583553 2579805 2583554 2580597 2583555 2580596 2583556 2580598 2583557 2580599 2583558 2580600 2583559 2580601 2583560 2583561 2583562 2583563
513	Klammer (10 Stk.) Clip (10 pcs) Clip (10 pcs)		2579806
514	Winkelhalter Angle bracket Equerre		2579807
515	Verschraubung (30 Stk.) Fittings (30 pcs) Vissage (30 pcs)		2579808
516	Stützfuss Leg support Support à pied		2583378
—	Bohrschrauben (30 Stk.) Drilling screws (30 pcs) Vis autoperceuse (30 pcs)		2579715

Zentraleinheit Typ B mit Sterilfilter
 Central unit Type B with sterile filter
 Unité centrale Type B avec filtre stérile

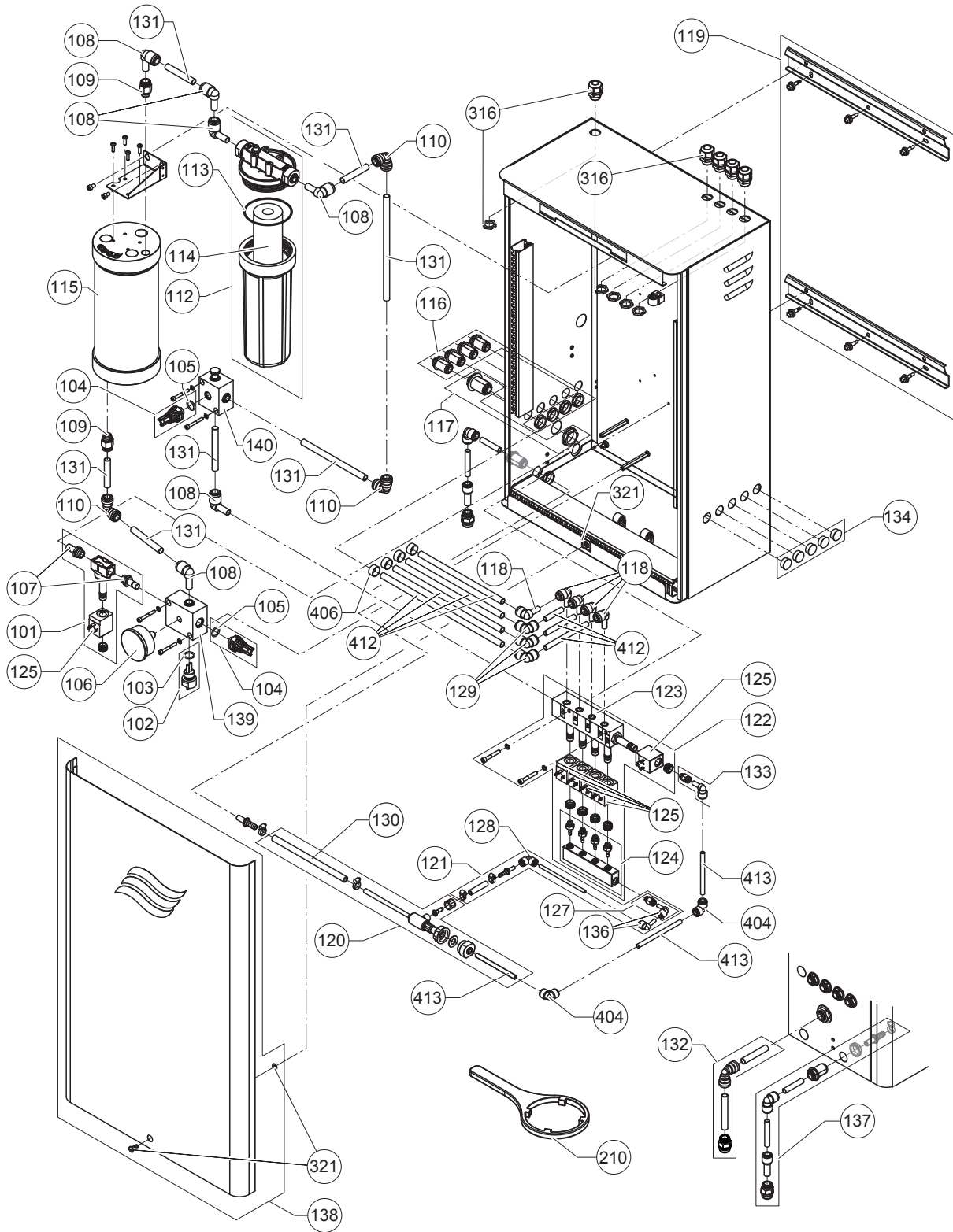

Zentraleinheit Typ B ohne Sterilfilter
 Central unit Type B without sterile filter
 Unité centrale Type B sans filtre stérile

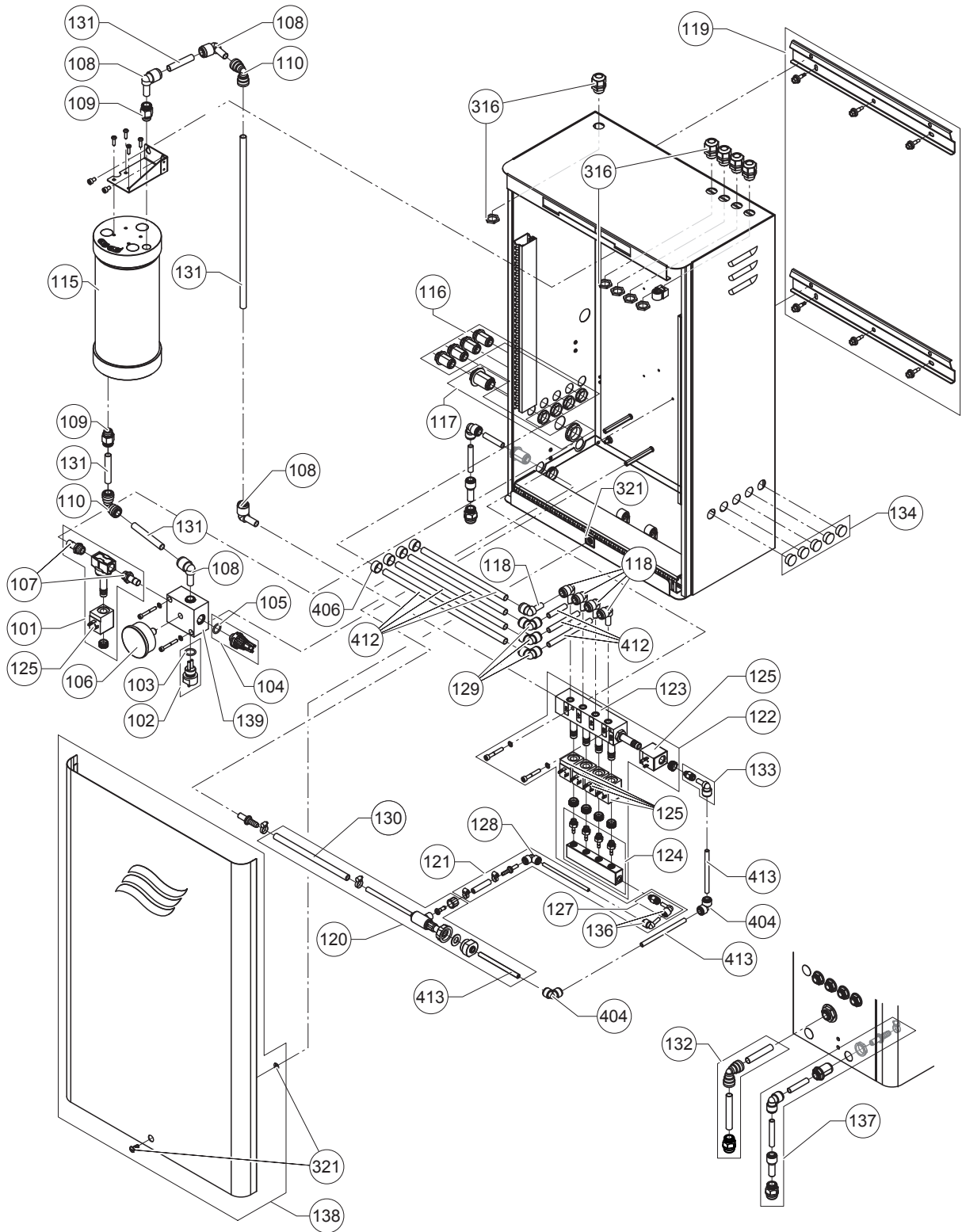

Steuereinheit
Control unit
Unité de commande

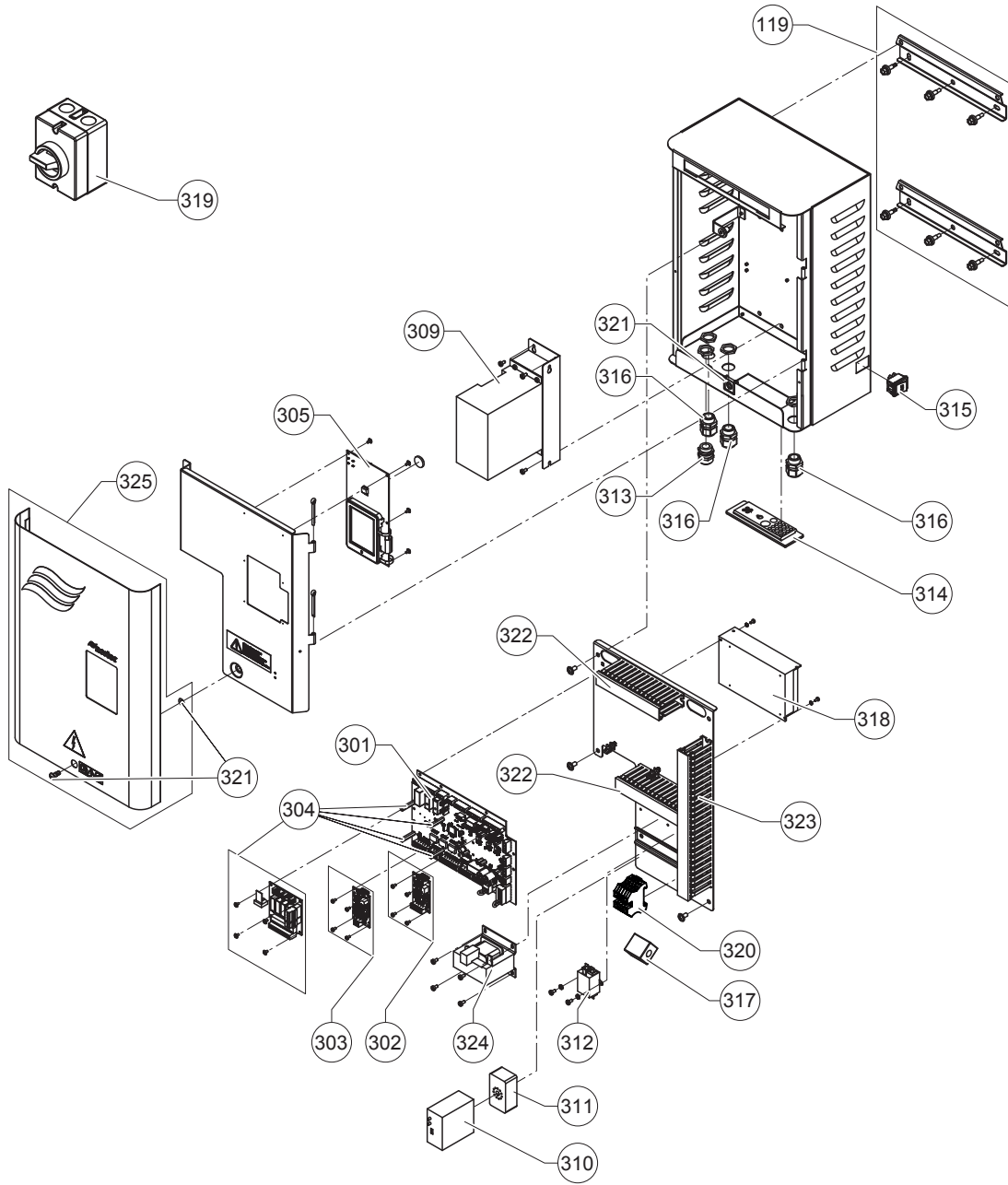

Düsensystem
 Nozzle system
 Système des buses

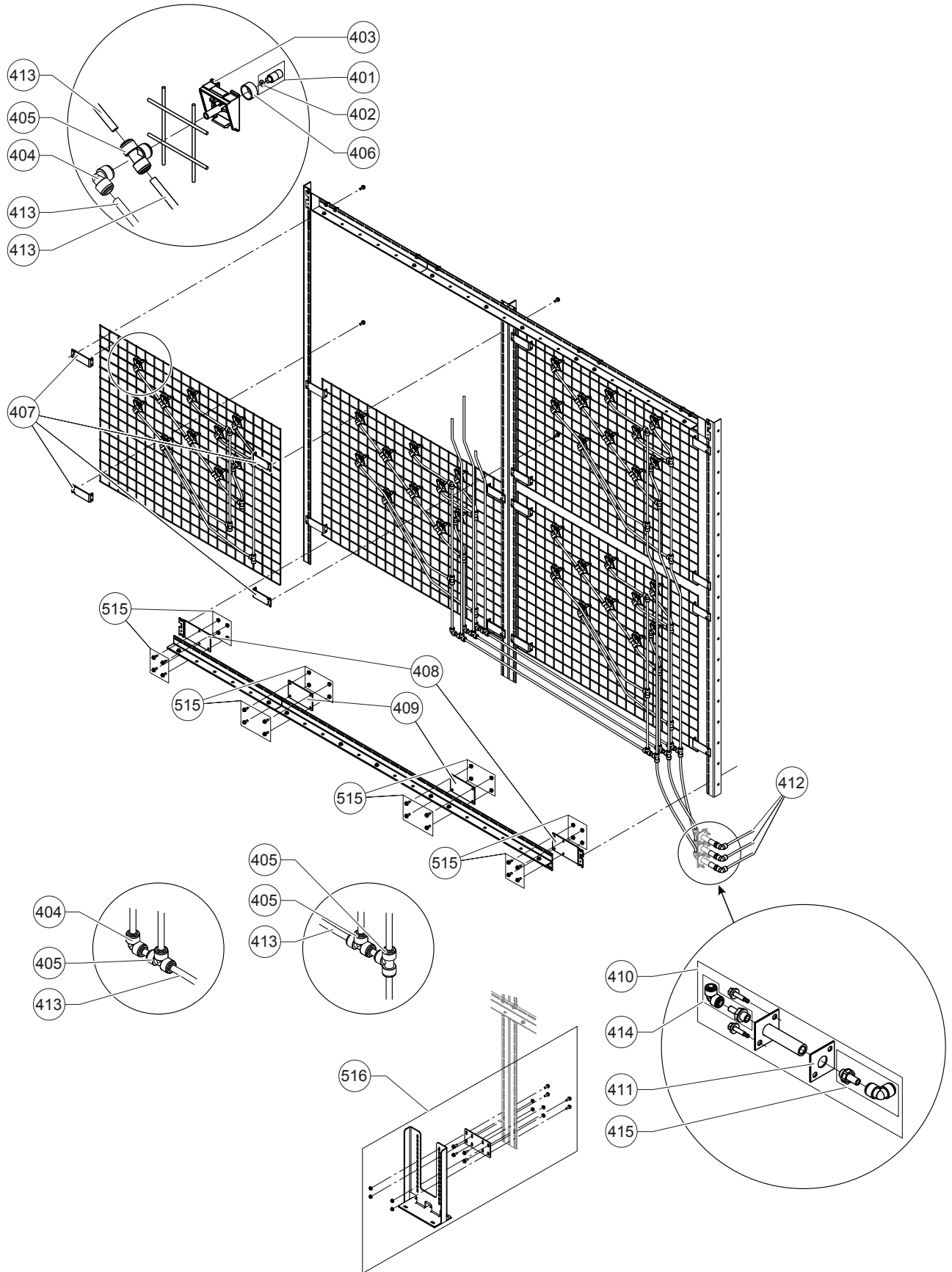

Nachverdunstereinheit
Post evaporation unit
Unité posthumidification

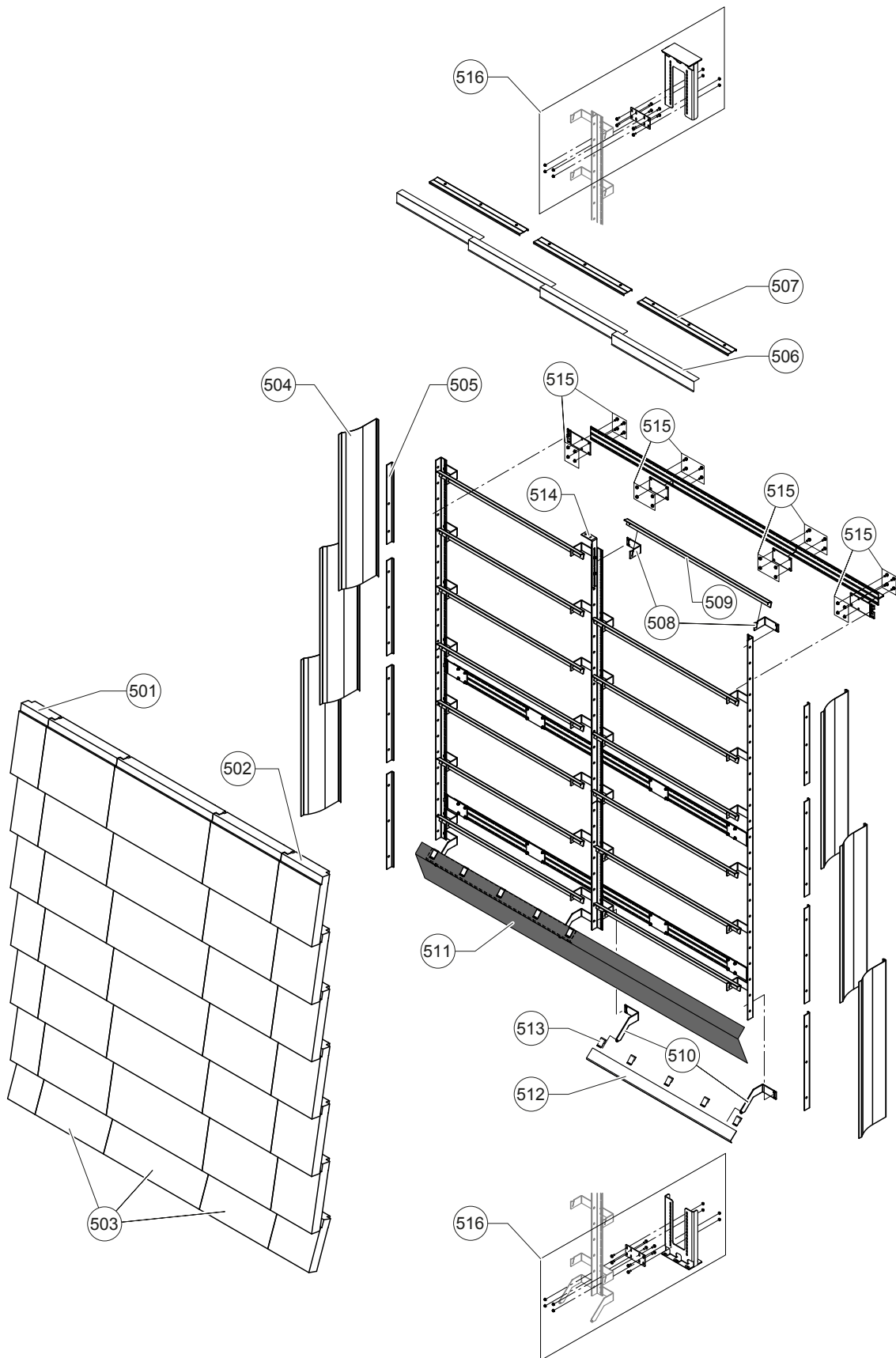



www.condairparts.com

Buy authentic Condair
parts factory direct.

Would you recommend Condair?
Take our two question survey.



U.S.A.
1021 6th Street
Racine, WI 53403

CANADA
2740 Fenton Road
Ottawa, Ontario K1T 3T7

TEL: 1.866.667.8321
EMAIL: na.info@condair.com
WEBSITE: www.condair.com

