



Important: Read and save these instructions. This guide to be left with equipment owner.



Modbus

Installation and Operation Manual

Using Modbus with Condair Humidifiers. Includes installation, operation maintenance and troubleshooting information.



Thank you for choosing Condair.

INSTALLATION DATE (MM/DD/YYYY)

MODEL #

SERIAL #

CYLINDER #

Proprietary Notice

This document and the information disclosed herein are proprietary data of **Condair**. Neither this document nor the information contained herein shall be reproduced, used, or disclosed to others without the written authorization of **Condair**, except to the extent required for installation or maintenance of recipient's equipment.

Liability Notice

Condair does not accept any liability for installations of humidity equipment installed by unqualified personnel or the use of parts/components/equipment that are not authorized or approved by Condair.

Copyright Notice

Copyright 2019, **Condair**. All rights reserved.

Contents

Introduction	2
Requirements	2
Wiring Connections	2
<i>Nortec EL/NH-EL Models</i>	4
<i>Nortec NHTC, -GSTC, -SETC, and -MHTC Models</i>	5
<i>Nortec MES2 and Nortec RH2 Models</i>	5
<i>Nortec NHRS Models</i>	5
<i>Nortec EL/NH-EL Modbus RTU Connection</i>	6
<i>Nortec NHTC, GSTC B+, and SETC B+ Modbus RTU Connection</i>	7
<i>Nortec MES2 and Nortec RH2 Modbus Wiring Diagram</i>	8
<i>Nortec NHRS Modbus RTU Connection</i>	9
Addressing and Communications	10
<i>Nortec EL Electrode Steam Humidifiers</i>	10
<i>Nortec NH-EL Electrode Steam Humidifiers</i>	16
<i>Nortec NHTC Electrode Steam Humidifiers</i>	21
<i>Nortec GSTC Gas Fired Steam Humidifiers</i>	27
<i>Nortec SETC Steam Exchange Humidifiers</i>	31
<i>Nortec MHTC Evaporative Media Humidifiers</i>	35
<i>Nortec MES2 and Nortec RH2 Models</i>	39
<i>Nortec NHRS Electric Steam Humidifiers</i>	45
Troubleshooting	48
Appendix A	51
<i>Modbus – Field Retrofit for Nortec NHRS Models</i>	51

**CAUTION: Servicing**

- Disconnect main power before any servicing.
- The plumbing and electrical compartments contain high voltage components and wiring. Access should be limited to authorized personnel only.
- During and following operation of the humidifier, the steam and components in contact with the steam such as the blower pack, steam lines, steam distributors, and condensate lines can become hot and can burn if touched.
- Condair does not accept any liability for installations of humidity equipment installed by unqualified personnel or the use of parts/components/equipment that are not authorized or approved by Condair.

**CAUTION: Electrical**

- All electrical work should be done according to local and national electrical code.
- Electrical connection to be performed by a licensed electrician.

**CAUTION: Installation**

- Do not mount on hot surfaces.
- Do not mount in area where freezing can occur.
- Do not mount on vibrating surface.
- Do not mount on floor.
- Regardless of selecting on/off or modulating control method, Condair humidifiers must have a closed circuit across its on/off security loop control terminal to operate. Condair highly recommends the use of a duct high limit humidistat.

Introduction

Many Condaire humidifiers feature control boards that include Modbus RTU and can connect to Modbus networks right out of the box. This document describes how to connect these humidifiers to such a network and defines the parameters that may be monitored. Please note that there are differences between Modbus RTU and Modbus TCP. Condaire humidifiers are Modbus RTU capable and require a gateway (by others) for Modbus TCP networks. Contact the factory for more information on Modbus TCP communications.

Requirements

Nortec EL/NH-EL Humidifiers are capable of Modbus RTU and require no additional hardware for this connection.

Condaire humidifiers that feature that Total Controller (“TC”) control boards are also capable of Modbus RTU. These include the Nortec NHTC, the Nortec GSTC, Nortec SETC, and Nortec MHTC humidifiers.

Additionally, the Nortec RH2 and Nortec MES-2 models feature a digital control board that supports Modbus, however these models require an adapter board to provide the Modbus interface. Finally, the Nortec NHRS also supports Modbus communications; however a TTL converter is required for this functionality. Refer to following table for more information, items described as “optional” are for convenience (but not required for Modbus), while items listed as required are needed for Modbus functionality:

Table 1: Modbus Accessories

Part Number	Kit Name	Kit Description
2553787	NHTC, GSTC, SETC Modbus Connection	Optional adapter cable for Nortec NHTC, Nortec GSTC, Nortec SETC.
2560630	MHTC Modbus Interface	Optional terminal block for MHTC Modbus interface.
2531585	Modbus Option for OEM Digital Board	Required adapter board and terminals for Modbus connections.
2560631	NHRS Modbus converter	Required TTL converter for NHRS Modbus connections.

Please consult your local Condaire representative to orders connection kits.

Wiring Connections

Using the correct wiring between the humidifier and the Modbus network is important to ensure reliable communications and reduce the impact of electrical interference. The recommended wire type is 18 -24 AWG, shielded twisted pair wire with 120 Ohm characteristic impedance. As an alternative, CAT-5 (“Ethernet”) cable exceeds these specifications and may be used. In this case, only two of the conductors and the wire shield will be used; care must be taken to isolate any unused conductors.

Regardless of which wire type is used ensuring the correct shield terminations is necessary to prevent electrical interference. The wire shield should be terminated at either the humidifier or the Modbus system, but not both. This allows induced current to “drain”; if the shield is terminated at both ends it will function as a conductor and can actually increase electrical

interference. To minimize signal loss a wire run should not exceed 2000 feet. Additionally, to ensure communication reliability, it is recommended that no more than 8 humidifiers are connected to a single chain/bus. The humidifiers should be the same type but do not need to be the same capacity. For example it is not recommended to have an Nortec NHTC and a Nortec GSTC as part of the same chain, but it is acceptable to have an Nortec NHTC-200 and an Nortec NHTC-30 as part of the same chain. Connecting additional non-Condair equipment into a Modbus chain is possible; however it is important to ensure that all devices are operating with identical baud rate, parity, and stop bits, and that each device has a unique Modbus address.

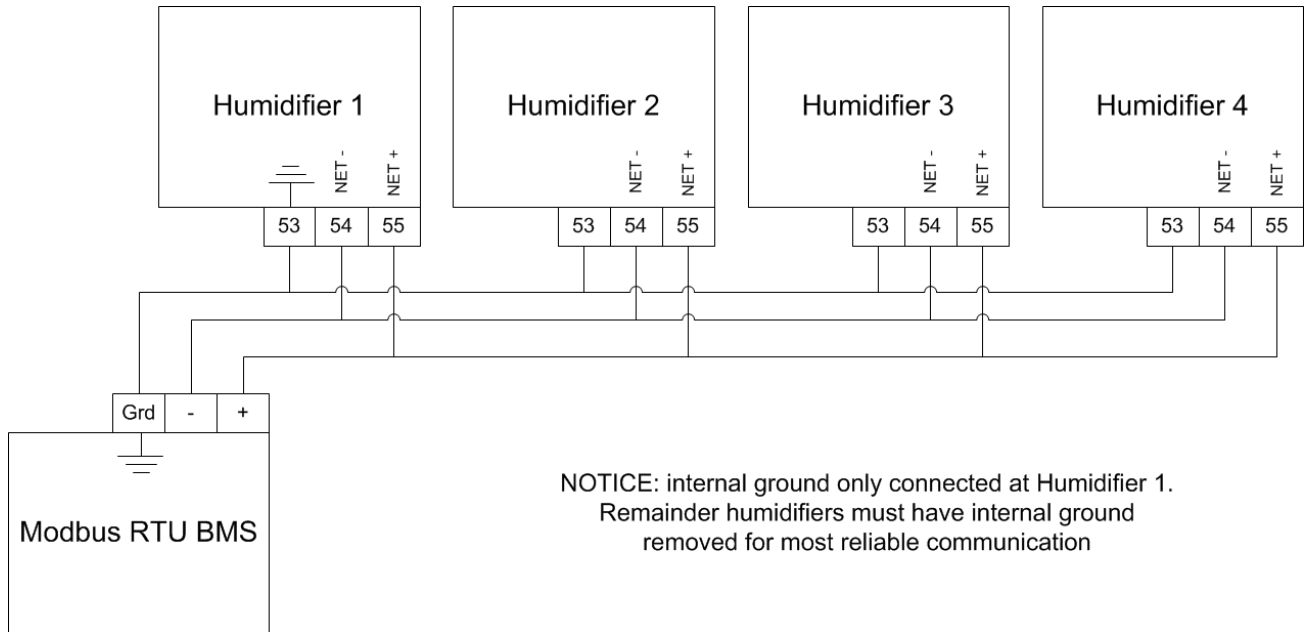

Figure 1: Example Daisy Chain Diagram for Nortec EL/NH-EL, Nortec NHTC, Nortec GS, Nortec SE

Nortec EL/NH-EL Models

The Nortec EL/NH-EL models use a 3-pole connector on the main processor card for Modbus connection. This 3-pole connector is provided with all Nortec EL/NH-EL and connections can be made directly to this plug. Refer to Figure 2 and Figure 3 for connection location and wiring.

Please note: there is a 120 Ohm termination resistor available on board. When the jumper J4 is on, 120 Ohm is enabled. When the jumper J4 is off, 120 Ohm is disabled.

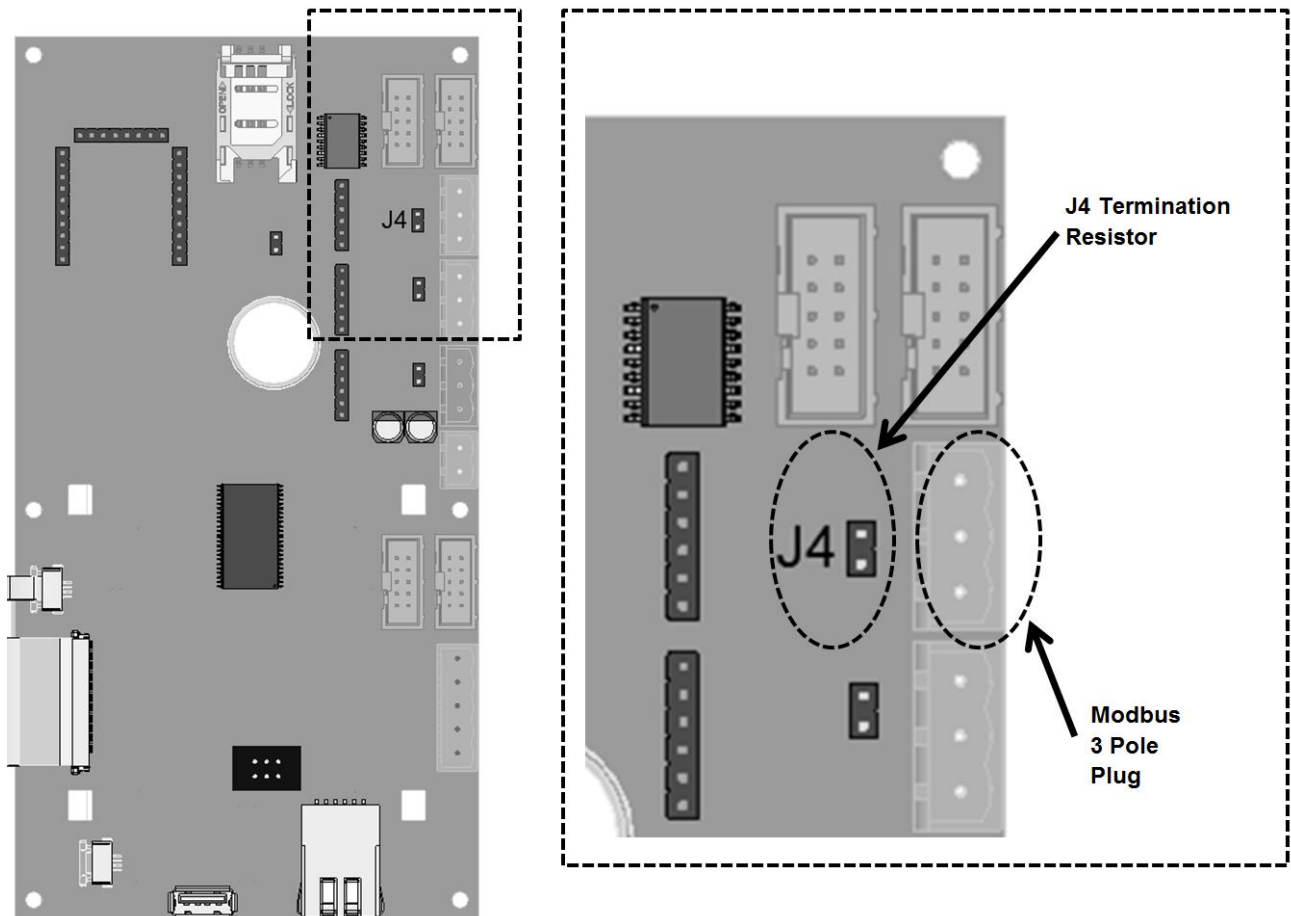

Figure 2: Nortec EL/NH-EL Modbus 3-Pole Plug Location

Nortec NHTC, -GSTC, -SETC, and -MHTC Models

The Nortec NHTC, Nortec GSTC, Nortec SETC, and Nortec MHTC models use a multifunction RJ45 plug on the mainboard to provide Modbus communications. Connections can be made directly to this plug or, alternatively, using one of accessories listed above.

Refer to figure 4 for information on the wiring connections for these units.

Note: This instruction manual covers the connections and points for the Nortec GSTC B+ and Nortec SETC B+ models only. Older models, manufactured pre-2009 do not include the RJ45 plug and require an additional interface cable. Contact Condaire for information on connecting these units.

Nortec MES2 and Nortec RH2 Models

The Nortec MES2 and Nortec RH2 models require a Modbus support board to provide a connection point. This board can be factory installed if indicated at time of order, or retrofit to existing units in the field.

Refer to Figure 5 for information on the wiring connections for these units.

Nortec NHRS Models

The Nortec NHRS models require a Modbus kit to translate information from the processor board into Modbus RTU information. This kit can be factory installed if specified at time of order or retrofit to existing units in the field. Refer to figure 6 for information on the wiring connections for these units.

Nortec EL/NH-EL Modbus RTU Connection

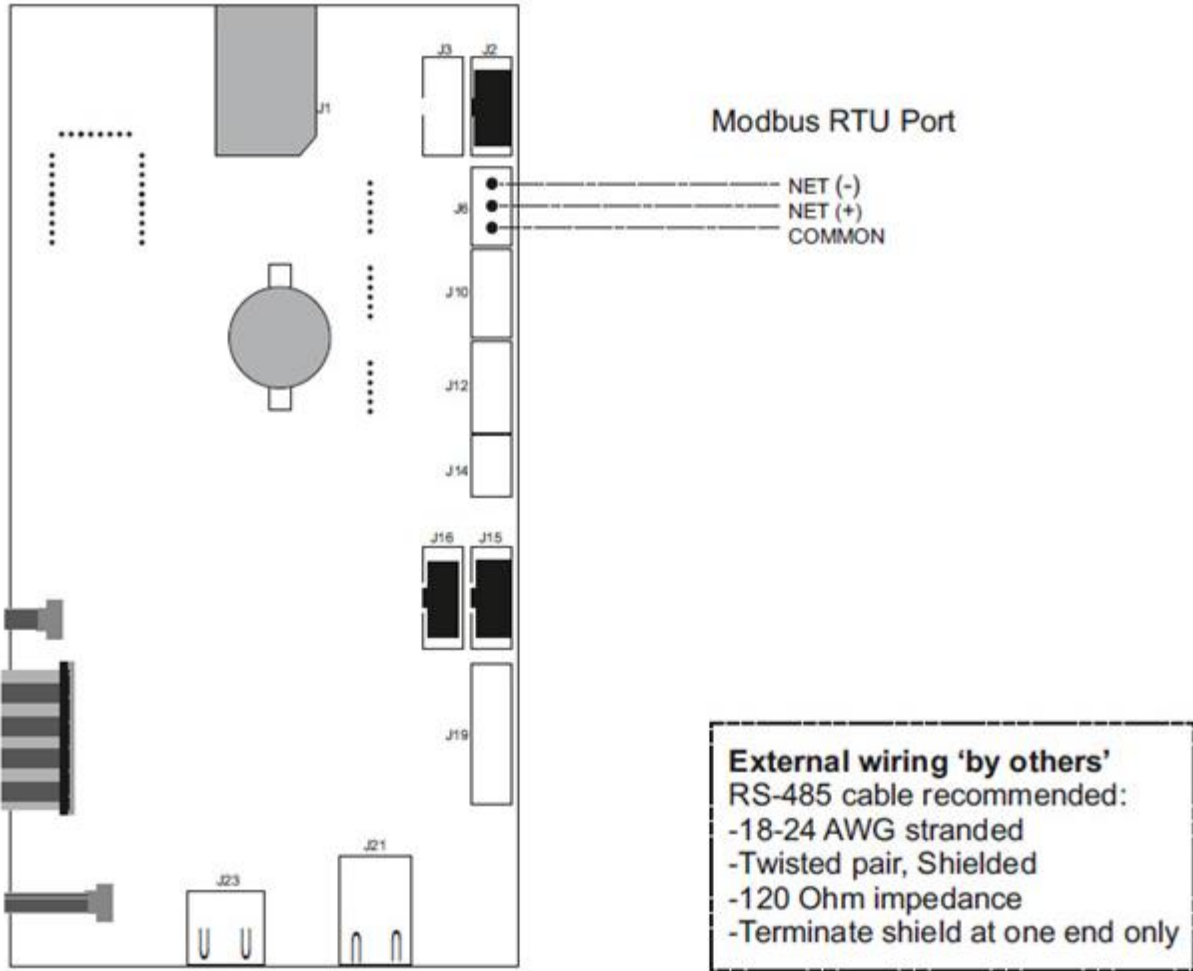
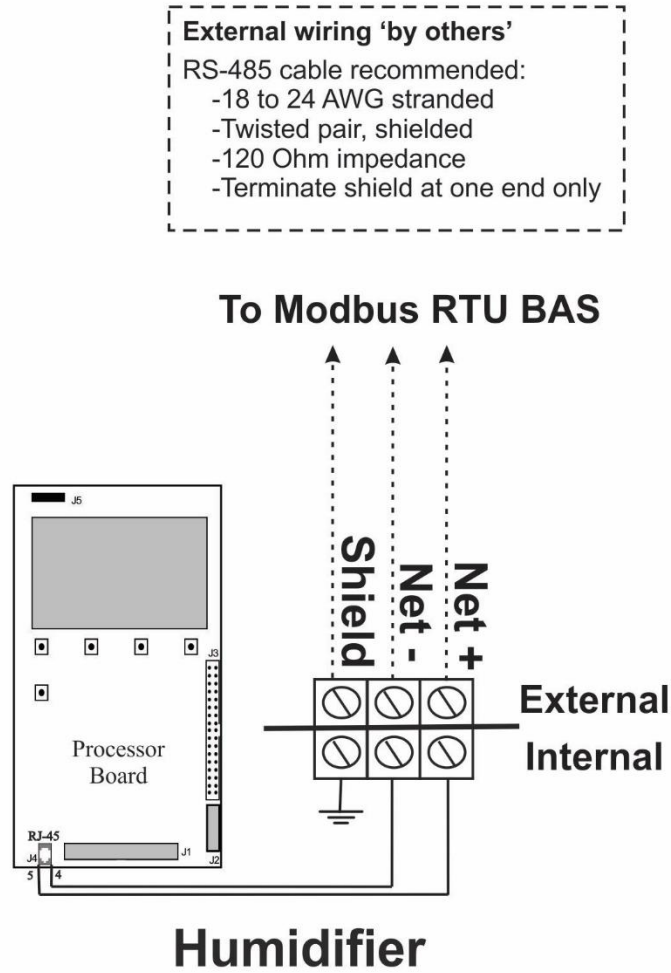

Figure 3: Nortec EL/NH-EL Modbus Wiring Diagram

Nortec NHTC, Nortec GSTC B+, and Nortec SETC B+ Modbus RTU Connection



The Modbus Connection option provides a cable and 3-pole terminal strip that is factory mounted inside of the humidifier. The NET+ and NET- terminals allow for a 2 wire connection to a Modbus RTU type building automation system (BAS). A third terminal is used to ground the wire shield. To prevent electrical interference, it is important to ground the wire shield at one end (humidifier or BAS) only.

Communication between the humidifiers and the BAS occurs via an EIA-485 signal type. Nortec recommends using 18 to 24 AWG shielded, twisted pair wire between the humidifier and the BAS. The cable should have a characteristic impedance of 120 ohms. Cable runs should not exceed 2,000 feet. For longer wire runs signal boosters or repeaters may be necessary.

Figure 4: TC Modbus Wiring Diagram

Nortec MES2 and Nortec RH2 Modbus Wiring Diagram

Modulation:

Remove J10 for 0-10 VDC

Remove Jumper J10 and place it on J13 for 2-10VDC

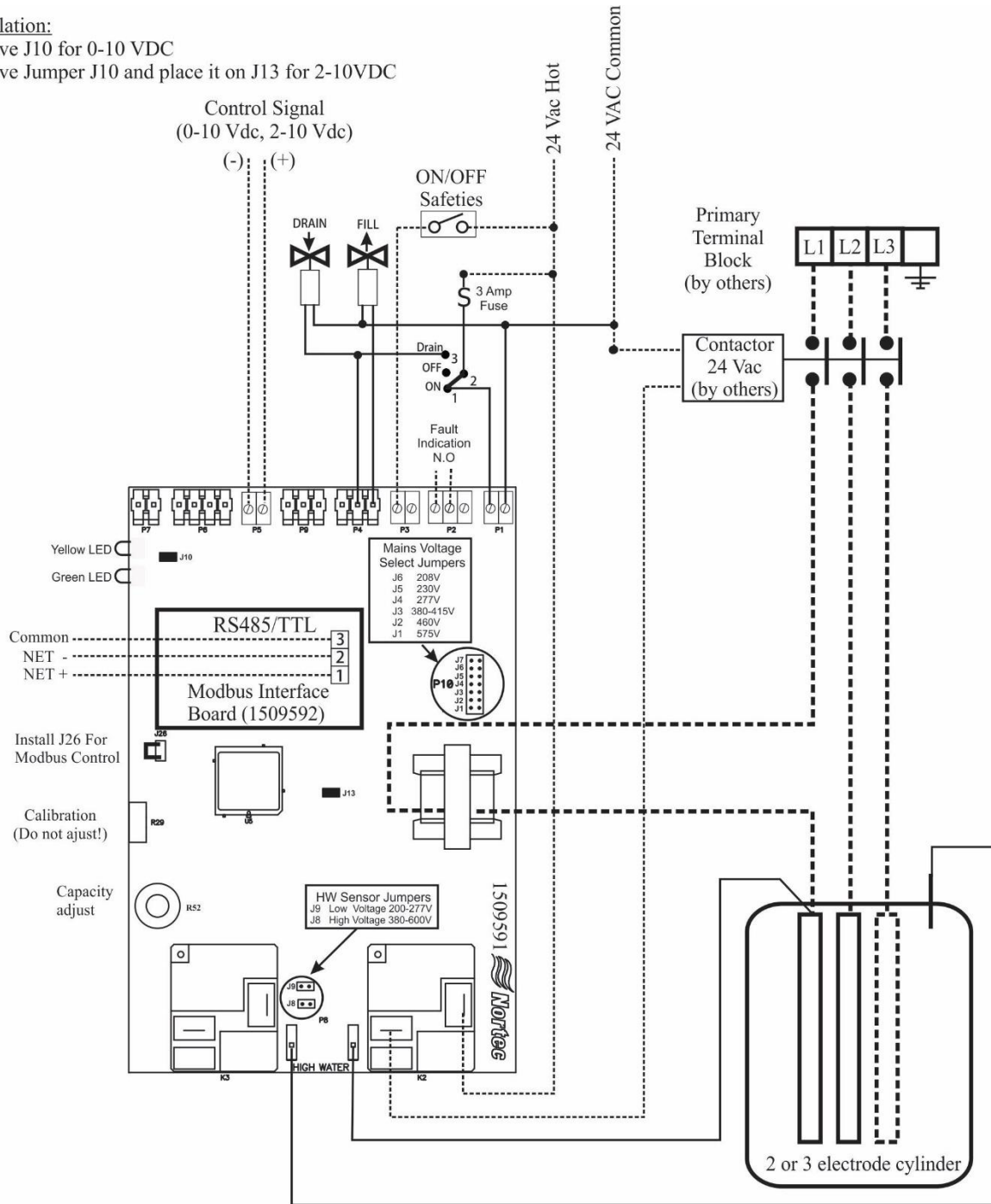

NOTE: Dotted lines denote wiring by others with the exception of Primary Voltage Wiring (PVW) units which will come with all primary wiring to the cylinder and 10' of wiring to run the electrical back to the contactor

Figure 5: Nortec MES2 and Nortec RH2 Modbus Wiring Diagram

Nortec NHRS Modbus RTU Connection

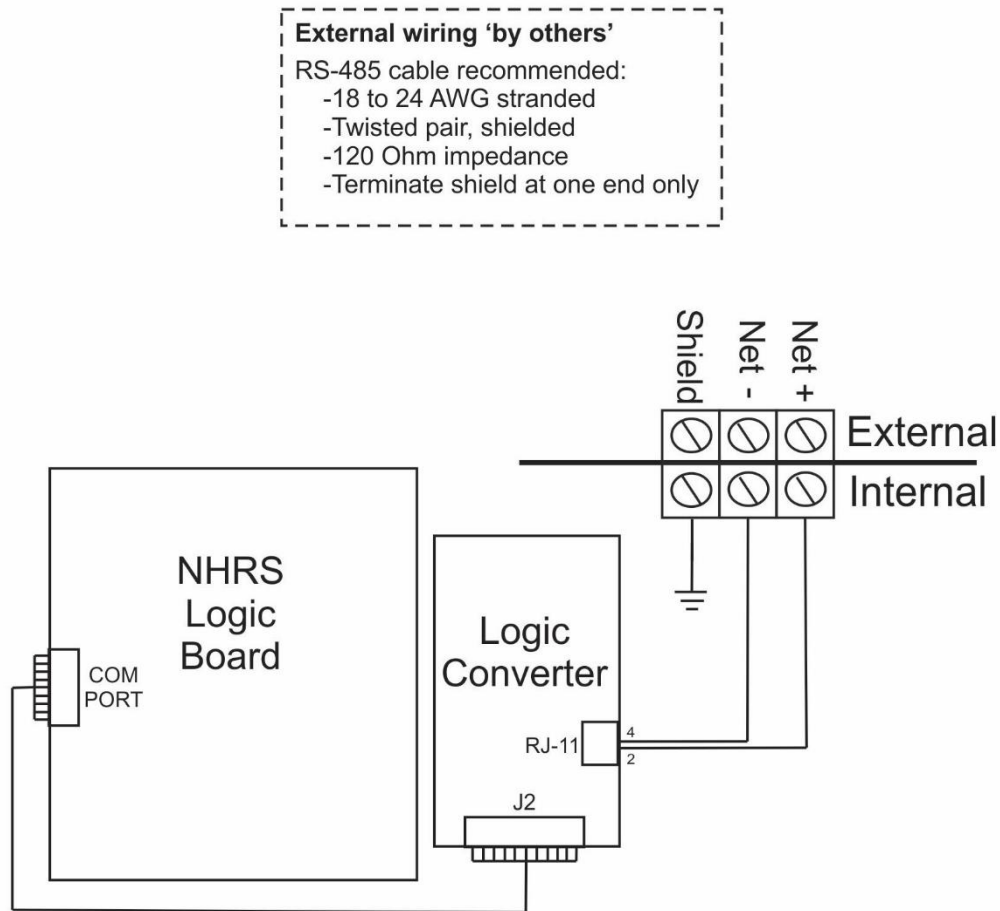

The Modbus Connection option provides a logic converter, cable, and a 3-pole terminal strip that is factory mounted or field retrofit inside of a humidifier. The NET+ and NET- terminals allow for a 2 wire connection a Modbus RTU type building automation system. A third terminal is used to ground the wire shield. To prevent electrical interference, it is important to ground the wire shield at one end (humidifier or network) only.

Communication between the humidifiers and the Modbus network occurs over an EIA-485 signal. Nortec recommends using 18 - 24 AWG shielded twisted pair wire between the humidifier and the network. The cable should have a characteristic impedance of 120 ohms. Cable runs should not exceed 2,000 feet. Signal boosters or repeaters may be necessary for long wire runs.

Figure 6: Nortec NHRS Modbus Wiring Diagram

Addressing and Communications

Once the humidifier is wired to the network, control variables must be mapped to allow for control of the humidifier. The specific variables and communications requirements for each humidifier are described in the following sections.

Nortec EL Electrode Steam Humidifiers

After wiring connections have been completed, the humidifier needs to be setup to operate and communicate either through the Modbus or BACnet interface.

Modbus Communication Set-up

The default Modbus address for the Nortec EL is 10. If multiple units were included on an order, the addresses of individual units may vary. To view or change the Modbus address:

- 1 Press the *Menu* icon on the lower left corner of the screen, to access the menu.
- 2 When prompted for a password, enter 0335 using the number pad. Press the *Check Mark* icon to confirm.
- 3 Select the *Configuration* menu.
- 4 Select the *Comms.* menu.
- 5 Using the navigation buttons on the top right of the screen, scroll down to the *Modbus Parameters*.

Note: By default, Modbus is disabled. To enable Modbus, select **Modbus** under *Modbus Parameters*. Select **ON** and confirm the selection by pressing the **Check Mark** button.

- 6 Select the *Modbus Address* setting. Using the *Up* and *Down* arrows, select a value between 1 and 247 inclusive as desired and press the *Check Mark* button to confirm the selection. It is recommended to leave the parity and baud rate settings to their factory defaults (Even and 9600 respectively) unless communication problems occur.
- 7 Press *Back* repeatedly until you return to the home screen.

This procedure is summarized below:

Main Menu > 0335 > Configuration > Comms. Menu > Modbus Parameters >

Addr: 10 (1 – 247 acceptable)

Parity: Even (None, Even, Odd)

Baud Rate: 9600 (9600, 19200, 38400, 115200)

Control Signal Setting

By default the humidifier is configured operate on a hardwired control signal supplied through the unit terminal strip. This can be changed to allow the humidifier to function entirely through its Modbus or BACnet interface.

To adjust this setting:

- 1 Press the *Menu* icon on the lower left corner of the screen, to access the menu.
- 2 When prompted for a password, enter 0335 using the number pad. Press the *Check Mark* icon to confirm.
- 3 Select the *Configuration* menu.
- 4 Select the *Control Settings* menu. The following settings can be adjusted:

Source	<i>Analog</i> : Use hardwired control signal <i>Modbus</i> : Write control signal through Modbus interface
Control Mode	<i>Demand</i> : Use a demand control signal <i>RH P</i> : Use a sensor value and proportional <i>RH PI</i> : Use a sensor value and proportional-integral control band
Control Channels	<i>Single</i> : Use a signal channel control signal <i>Dual</i> : Use a dual channel control signal

Note: Refer to the Operator Interface section of the Nortec EL Operation and Maintenance Manual for more information on the above settings.

- 5 Press *Check Mark* to confirm choice and then *Back* repeatedly to return to the home screen when complete.

This procedure is summarized below:

Main Menu > 0335 > Configuration > Control Settings >

Source: *Analog, Modbus,*

Control Mode: *Demand, RH P, or RH PI*

Control Channels: *Single or Dual*

Modbus Parameters

The Nortec EL uses the following parameters for Modbus communication:

Signaling Type	EIA-485
Transmission Mode	RTU
Baud Rate	9600
Data Bits	8
Stop Bits	1
Parity	Even
Address / Unit Number	10*

**Default, may vary for multi-unit orders.*

It is important to note that the signaling type, transmission mode, data bits and stop bits cannot be modified. Parity, baud rate and unit address can be modified as required.

The following points may be mapped for control:

Table 2: Nortec EL Humidifier Modbus Parameters

Parameter Name	Description	Modbus Addr.	Type	Format	Range	Unit	W/R	Details
Remote Disable	Remotely disable steam production for the unit	40001	Holding Register	Integer	0 OR 1	-	WRITE/READ	0 = Idle/Humidify 1 = Disable
Manual Capacity A	Sets a manual capacity limit restriction for cylinder A	40002	Holding Register	Integer	20-100	%	WRITE/READ	Limits output to percentage of total cylinder capacity for cylinder A (EL-150 and Nortec EL-200 models only)
Setpoint Channel A1	Sets the desired humidity setpoint value for Channel A1	40003	Holding Register	Integer	0-95	%	WRITE/READ	Use only when sending RH values to Digital RH/Demand A1. For most common configurations this is the primary space setpoint
Setpoint Channel A2	Sets the humidity high limit setpoint value for Channel A2	40004	Holding Register	Integer	10-95	%	WRITE/READ	Use only when sending RH value to Digital RH/Demand A2 with dual channel control enabled
Digital RH/Demand A1	Actual humidity or demand via BACnet unit A	40005	Holding Register	Integer	0-100	%	WRITE/READ	Requires Modbus or BACnet to be enabled. For most common configurations, this is the primary control signal
Digital RH/Demand A2	Actual humidity or limiter via BACnet unit A	40006	Holding Register	Integer	0-100	%	WRITE/READ	Requires Modbus or BACnet to be enabled. Only applies to Nortec EL-150 and Nortec EL-200 with cylinders in independent operation mode
Manual Capacity B	Sets a manual capacity limit restriction for cylinder B	40007	Holding Register	Integer	20-100	%	WRITE/READ	Limits output to percentage of total cylinder capacity for cylinder B (Nortec EL-150 and Nortec EL-200 models only)
Setpoint Channel B1	Sets the desired humidity setpoint value for Channel B1	40008	Holding Register	Integer	0-95%	%	WRITE/READ	Use only with Nortec EL-150 and Nortec EL-200 models when sending RH value to Digital RH/Demand B1 and cylinders are in independent operation mode

Parameter Name	Description	Modbus Addr.	Type	Format	Range	Unit	W/R	Details
Setpoint Channel B2	Sets the humidity high limit setpoint value for Channel B2	40009	Holding Register	Integer	10-95	%	WRITE/READ	Use only with Nortec EL-150 and Nortec EL-200 models when sending RH value to Digital RH/Demand B2 with dual channel control enabled and cylinders are in independent operation mode
Digital RH/Demand B1	Actual humidity or demand via BACnet unit B	40010	Holding Register	Integer	0-100	%	WRITE/READ	Requires Modbus or BACnet to be enabled. Only applies to Nortec EL-150 and Nortec EL-200 with dual channel control enabled
Digital RH/Demand B2	Actual humidity or limiter via BACnet unit B	40011	Holding Register	Integer	0-100	%	WRITE/READ	Requires Modbus or BACnet to be enabled. Only applies to Nortec EL-150 and Nortec EL-200 with cylinders dual channel control enabled and cylinders in independent operation mode
BAND CHANNEL A1	P-band unit A (proportional band)	40017	Holding Register	Integer	6-65	%	WRITE/READ	
BAND CHANNEL A2	P-band unit A (proportional band) limiter	40018	Holding Register	Integer	6-65	%	WRITE/READ	
BAND CHANNEL B1	P-band unit B (proportional band)	40019	Holding Register	Integer	6-65	%	WRITE/READ	
BAND CHANNEL B2	P-band unit B (proportional band) limiter	40020	Holding Register	Integer	6-65	%	WRITE/READ	
ITime Channel A1	Integral time channel 1 unit A	40021	Holding Register	Integer	1-60	min	WRITE/READ	
Damp Channel A2	Damp time channel 2 unit A	40022	Holding Register	Integer	1-60	sec	WRITE/READ	
ITime Channel B1	Integral time channel 1 unit B	40023	Holding Register	Integer	1-60	min	WRITE/READ	
Damp Channel B2	Damp time channel 2 unit B	40024	Holding Register	Integer	1-60	sec	WRITE/READ	
Enable Input A	Enable contact unit A	30002	Input Register	Integer	0 OR 1	-	READ	0 = Off 1 = On
Channel A1	Input signal channel 1 unit A	30004	Input Register	Integer	0-100	%	READ	Displays channel 1 demand/sensed RH as a percentage of cylinder capacity for cylinder A

Parameter Name	Description	Modbus Addr.	Type	Format	Range	Unit	W/R	Details
Channel A2	Limiter signal channel 2 unit A	30005	Input Register	Integer	0-100	%	READ	Displays channel 2 demand/sensed RH as a percentage of cylinder capacity for cylinder A
System Demand A	System Demand A	30006	Input Register	Integer	0-100	%	READ	Demand Mode: Summation of Channel A1 and Channel A2 RH Mode: PID calculation
Safety Loop A	External safety loop unit A	30007	Input Register	Integer	0 OR 1	-	READ	0 = Open 1 = Closed
Blower Pack A	Blower ready unit A	30008	Input Register	Integer	0 OR 1	-	READ	0 = Open 1 = Closed
FanActivate A	External fan unit A	30009	Input Register	Integer	0 OR 1	-	READ	0 = Open 1 = Closed
Operating Hours A	Operating hours unit A	30010	Input Register	Float CD AB	0-5000	Hrs	FLOAT CD AB	Displays the total time cylinder A has been running since last reset
Enable Input B	Enable contact unit B	30012	Input Register	Integer	0 OR 1	-	READ	0 = Off 1 = On
Channel B1	Input signal channel 1 unit B	30014	Input Register	Integer	0-100	%	READ	Displays channel 1 demand/sensed RH as a percentage of cylinder capacity for cylinder B (Nortec EL-150 and Nortec EL-200 models only)
Channel B2	Limiter signal channel 2 unit B	30015	Input Register	Integer	0-100	%	READ	Displays channel 2 demand/sensed RH as a percentage of cylinder capacity for cylinder B (Nortec EL-150 and Nortec EL-200 models only)
System Demand B	System Demand B	30016	Input Register	Integer	0-100	%	READ	Demand Mode: Summation of Channel B1 and Channel B2 RH Mode: PID calculation
Safety Loop B	External safety loop unit B	30017	Input Register	Integer	0 OR 1	-	READ	0 = Open 1 = Closed
Blower Pack B	Blower ready unit B	30018	Input Register	Integer	0 OR 1	-	READ	0 = Open 1 = Closed
FanActivate B	External fan unit B	30019	Input Register	Integer	0 OR 1	-	READ	0 = Open 1 = Closed
Operating Hours B	Operating hours unit B	30020	Input Register	Float CD AB	0-5000	Hrs	FLOAT CD AB	Displays the total time cylinder B has been running since last reset

Parameter Name	Description	Modbus Addr.	Type	Format	Range	Unit	W/R	Details
Status A	Operating status unit A	31003	Input Register	Integer	0-13	-	READ	0-Humidifying 1-Standby 2-Idle Drained 3-Keep Warm 4-Filling 5-Draining 6-Remote Off 7-Safety Loop 8-Warning 9-Fault 10-Blower Pack 11-Stopped 12-Partial Drained 13-Self Test
Service Status B	Maintenance and malfunctions status unit B	31026	Input Register	Integer	0-13	-	READ	0-Humidifying 1-Standby 2-Idle Drained 3-Keep Warm 4-Filling 5-Draining 6-Remote Off 7-Safety Loop 8-Warning 9-Fault 10-Blower Pack 11-Stopped 12-Partial Drained 13-Self Test
Main Contactor A	Contactor unit A	31200	Input Register	Integer	0 OR 1	-	READ	0 = Off 1 = On
Main Contactor B	Contactor unit B	31201	Input Register	Integer	0 OR 1	-	READ	0 = Off 1 = On
Inlet A	Inlet valve unit A	31202	Input Register	Integer	0 OR 1	-	READ	0 = Off 1 = On
Inlet B	Inlet valve unit B	31203	Input Register	Integer	0 OR 1	-	READ	0 = Off 1 = On
Drain A	Drain valve unit A	31204	Input Register	Integer	0 OR 1	-	READ	0 = Off 1 = On
Drain B	Drain valve unit B	31205	Input Register	Integer	0 OR 1	-	READ	0 = Off 1 = On

Nortec NH-EL Electrode Steam Humidifiers

After wiring connections have been completed, the humidifier needs to be setup to operate and communicate either through the Modbus or BACnet interface.

Modbus Communication Set-up

The default Modbus address for a Nortec NH-EL is 10. If multiple units were included on an order, the addresses of individual units may vary. To view or change the Modbus address:

- 8 Press the *Menu* icon on the lower left corner of the screen, to access the menu.
- 9 When prompted for a password, enter 0335 using the number pad. Press the *Check Mark* icon to confirm.
- 10 Select the *Configuration* menu.
- 11 Select the *Comms.* menu.
- 12 Using the navigation buttons on the top right of the screen, scroll down to the *Modbus Parameters*.

Note: By default, Modbus is disabled. To enable Modbus, select *Modbus* under *Modbus Parameters*. Select *ON* and confirm the selection by pressing the *Check Mark* button.

- 13 Select the *Modbus Address* setting. Using the *Up* and *Down* arrows, select a value between 1 and 247 inclusive as desired and press the *Check Mark* button to confirm the selection. It is recommended to leave the parity and baud rate settings to their factory defaults (Even and 9600 respectively) unless communication problems occur.
- 14 Press *Back* repeatedly until you return to the home screen.

This procedure is summarized below:

Main Menu > 0335 > Configuration > Comms. Menu > Modbus Parameters >

Addr: 10 (1 - 247 acceptable)

Parity: Even (None, Even, Odd)

Baud Rate: 9600 (9600, 19200, 38400, 115200)

Control Signal Setting

By default the humidifier is configured operate on a hardwired control signal supplied through the unit terminal strip. This can be changed to allow the humidifier to function entirely through its Modbus or BACnet interface.

To adjust this setting:

- 6 Press the *Menu* icon on the lower left corner of the screen, to access the menu.
- 7 When prompted for a password, enter 0335 using the number pad. Press the *Check Mark* icon to confirm.
- 8 Select the *Configuration* menu.
- 9 Select the *Control Settings* menu. The following settings can be adjusted:

Source	<i>Analog:</i> Use hardwired control signal <i>Modbus:</i> Write control signal through Modbus interface
Control Mode	<i>Demand:</i> Use a demand control signal <i>RH P:</i> Use a sensor value and proportional <i>RH PI:</i> Use a sensor value and proportional-integral control band
Control Channels	<i>Single:</i> Use a signal channel control signal <i>Dual:</i> Use a dual channel control signal

Note: Refer to the CONTROL SETTING section of the Nortec NH Series Installation and Operation Manual for more information on the above settings.

- 10 Press *Check Mark* to confirm choice and then *Back* repeatedly to return to the home screen when complete.

This procedure is summarized below:

Main Menu > 0335 > Configuration > Control Settings >

Source: *Analog, Modbus,*

Control Mode: *Demand, RH P, or RH PI*

Control Channels: *Single or Dual*

Modbus Parameters

The Nortec NH-EL uses the following parameters for Modbus communication:

Signaling Type	EIA-485
Transmission Mode	RTU
Baud Rate	9600
Data Bits	8
Stop Bits	1
Parity	Even
Address / Unit Number	10*

*Default, may vary for multi-unit orders.

It is important to note that the signaling type, transmission mode, data bits and stop bits cannot be modified. Parity, baud rate and unit address can be modified as required.

The following points may be mapped for control:

Table 3: Nortec NH-EL Humidifier Modbus Parameters

Parameter Name	Description	Modbus Addr.	Type	Format	Range	Unit	R/W	Details
Dinput_A1	Write RH or Demand signal value to control channel 1 for cylinder A	40005	Holding Register	Integer	0 - 100	%	Write	Requires Modbus or BACnet to be enabled. For most common configurations, this is the primary control signal
Dinput_A2	Write RH or Demand signal value to control channel 2 for cylinder A	40006	Holding Register	Integer	0 - 100	%	Write	Requires Modbus or BACnet to be enabled. Only applies to Nortec NH-EL-150 and Nortec NH-EL-200 with cylinders in independent operation mode
Dinput_B1	Write RH or Demand signal value to control channel 1 for cylinder B	40010	Holding Register	Integer	0 - 100	%	Write	Requires Modbus or BACnet to be enabled. Only applies to Nortec NH-EL-150 and Nortec NH-EL-200 with dual channel control enabled
Dinput_B2	Write RH or Demand signal value to control channel 2 for cylinder B	40011	Holding Register	Integer	0 - 100	%	Write	Requires Modbus or BACnet to be enabled. Only applies to Nortec NH-EL-150 and Nortec NH-EL-200 with cylinders dual channel control enabled and cylinders in independent operation mode
Manual_Capcity_A	Sets a manual capacity limit restriction for cylinder A	40002	Holding Register	Integer	0 - 100	%	Write	Limits output to percentage of total cylinder capacity for cylinder A (Nortec NH-EL-150 and Nortec NH-EL-200 models only)
Manual_Capcity_B	Sets a manual capacity limit restriction for cylinder B (if present)	40007	Holding Register	Integer	0 - 100	%	Write	Limits output to percentage of total cylinder capacity for cylinder B (Nortec NH-EL-150 and Nortec NH-EL-200 models only)
BMS_Timeout	BMS timeout for Modbus and BACnet	40013	Holding Register	Integer	0 - 300	s	Write	It is recommend to not change the value from the factory default (300)
Remote_Disable	Remotely disable steam production for the unit	40001	Holding Register	Integer	0 or 1	-	Write	0 = Idle/Humidify 1 = Disable
SP_Chan_A 1	Writes the desired space setpoint for control channel 1 for cylinder A	40003	Holding Register	Integer	0 - 95	%	Write	Use only when sending RH values to Dinput_A1. For most common configurations this is the primary space setpoint
SP_Chan_A 2	Writes the desired space setpoint for control channel 2 for cylinder A	40004	Holding Register	Integer	10 - 95	%	Write	Use only when sending RH value to Dinput_A2 with dual channel control enabled
SP_Chan_B 1	Writes the desired space setpoint for control channel 1 for cylinder B	40008	Holding Register	Integer	0 - 95	%	Write	Use only with Nortec NH-EL-150 and Nortec NH-EL-200 models when sending RH value to Dinput_B1 and cylinders are in independent operation mode

Parameter Name	Description	Modbus Addr.	Type	Format	Range	Unit	R/W	Details
SP_Chan_B2	Writes the desired space setpoint for control channel 2 for cylinder B	40009	Holding Register	Integer	10 - 95	%	Write	Use only with Nortec NH-EL-150 and Nortec NH-EL-200 models when sending RH value to Dinput_B2 with dual channel control enabled and cylinders are in independent operation mode
Signal_Source	Selects signal source to control unit	40014	Holding Register	Integer	0 - 4	-	Write	0 = Analog 1 = Modbus 2 = BACnet/IP 3 = BACnet/MS 4 = LonWorks
Control_Mode	Selects method to control unit	40015	Holding Register	Integer	1 - 3	-	Write	1 = Demand 2 = RH P 3 = RH PI
Control_Channel	Selects method to control channels	40016	Holding Register	Integer	0 - 1	-	Write	0 = Single Channel 1 = Dual Channel
Input_A1	Displays channel 1 demand for cylinder A	30004	Input Register	Integer	0 - 100	%	Read	Displays channel 1 demand/sensed RH as a percentage of cylinder capacity for cylinder A
Input_A2	Displays channel 2 demand for cylinder A	30005	Input Register	Integer	0 - 100	%	Read	Displays channel 2 demand/sensed RH as a percentage of cylinder capacity for cylinder A
Input_B1	Displays channel 1 demand for cylinder B	30014	Input Register	Integer	0 - 100	%	Read	Displays channel 1 demand/sensed RH as a percentage of cylinder capacity for cylinder B (Nortec NH-EL-150 and Nortec NH-EL-200 models only)
Input_B2	Displays channel 2 demand for cylinder B	30015	Input Register	Integer	0 - 100	%	Read	Displays channel 2 demand/sensed RH as a percentage of cylinder capacity for cylinder B (Nortec NH-EL-150 and Nortec NH-EL-200 models only)
Blower_Pack_A	Reads the status of the blower pack for cylinder A	30008	Input Register	Integer	0 or 1	-	Read	0 = Open 1 = Closed
Blower_Pack_B	Reads the status of the blower pack for cylinder B	30018	Input Register	Integer	0 or 1	-	Read	0 = Open 1 = Closed
Fan_Activate_A	Indicates if air handle or furnace is activated for cylinder A	30009	Input Register	Integer	0 or 1	-	Read	0 = Not Activated 1 = Activated
Fan_Activate_B	Indicates if air handle or furnace is activated for cylinder B	30019	Input Register	Integer	0 or 1	-	Read	0 = Not Activated 1 = Activated
Do_Fault_A	Reads the status of a fault on the unit	30025	Input Register	Integer	0 or 1	-	Read	0 = No Fault 1 = Fault
Do_Service_A	Reads the status of a service request on the unit	30024	Input Register	Integer	0 or 1	-	Read	0 = No Service Required 1 = Service Required

Parameter Name	Description	Modbus Addr.	Type	Format	Range	Unit	R/W	Details
Humidifier_Status_A	Reads the status of the unit for cylinder A	30003	Input Register	Integer	0 - 9	-	Read	0 = Humidifying 1 = Idle 2 = Idle Drain 3 = Keepwarm 4 = Filling 5 = Draining 6 = Disabled 7 = Safety Loop 8 = Warning 9 = Fault
Humidifier_Status_B	Reads the status of the unit for cylinder A	30026	Input Register	Integer	0 - 9	-	Read	0 = Humidifying 1 = Idle 2 = Idle Drain 3 = Keepwarm 4 = Filling 5 = Draining 6 = Disabled 7 = Safety Loop 8 = Warning 9 = Fault
System_Demand_A	Reads the demand for cylinder A	30006	Input Register	Integer	0 - 100	%	Read	<u>Demand Mode:</u> Summation of Input_A1 and Input_A2 <u>RH Mode:</u> PID calculation
System_Demand_B	Reads the demand for cylinder A	30016	Input Register	Integer	0 - 100	%	Read	<u>Demand Mode:</u> Summation of Input_B1 and Input_B2 <u>RH Mode:</u> PID calculation
Safety_Loop_A	Reads the status of the safety loop for cylinder A	30007	Input Register	Integer	0 or 1	-	Read	0 = Open 1 = Closed
Safety_Loop_B	Reads the status of the safety loop for cylinder B	30017	Input Register	Integer	0 or 1	-	Read	0 = Open 1 = Closed
Run_Time_A	Reads operating time for cylinder A	30010	Input Register	Integer	0 - 5000	Hrs	Read	Displays the total time cylinder A has been running since last reset
Run_Time_B	Reads operating time for cylinder B	30020	Input Register	Integer	0 - 5000	Hrs	Read	Displays the total time cylinder B has been running since last reset
Weighted_Hours_A	Reads the weighted time for cylinder A	30011	Input Register	Integer	0 - 5000	Hrs	Read	An equated run time based on Run_Time_A x System_Demand_A
Weighted_Hours_B	Reads the weighted time for cylinder B	30021	Input Register	Integer	0 - 5000	Hrs	Read	An equated run time based on Run_Time_A x System_Demand_A

Nortec NHTC Electrode Steam Humidifiers

After wiring connections have been completed, the humidifier needs to be setup to operate and communicate through the Modbus interface.

Modbus Address

The default Modbus address for a Nortec NHTC is 1. If multiple units were included on an order, the addresses of individual units may vary. To view or change the unit number:

- 1 Press the *Menu* key to access the menu.
- 2 When prompted for a password, enter 0459 using the arrow keys. Press *Set* to confirm.
- 3 Select the *Factory Settings* menu and press the *Set* key.
- 4 Select the *Core Parameters* menu and press the *Set* key.
- 5 Select the *Modbus Parameters* menu and press the *Set* key.

Note: Do NOT modify other settings in the Factory settings manual. Adjusting other settings can cause serious damage to the humidifier.

- 11 Select the *Address* setting and press *Set* to modify. Enter a value between 1 and 127 inclusive as desired and press *Set* to confirm the solution. It is recommended to leave the parity and timeout settings to their factory defaults (Even and 300 respectively) unless communication problems occur.
- 12 Press *Esc* repeatedly until you return to the home screen.

This procedure is summarized below:

Menu > 0459 > Factory Settings > Core Parameters > Modbus Parameters >

Parity: *Even*

Addr: *1 (Default, 1 - 127 acceptable)*

Timeout: *300 seconds (Default, 5 - 600 acceptable)*

Control Signal Setting

By default the humidifier operation is configured on a hardwired control signal supplied through the unit terminal strip. This can be changed to allow the humidifier to function entirely through its Modbus interface.

To adjust this setting:

- 1 Press the *Menu* key to access the menu.
- 2 When prompted for a password, enter 0335 using the arrow keys. Confirm the password with set.
- 3 Select the *Control Settings* menu and press the *Set* key. The following settings can be adjusted:

Source	<i>Analog</i> : Use hardwired control signal <i>Digital</i> : Write control signal through Modbus interface
REG Mode	<i>Demand</i> : Use a demand control signal <i>RHp</i> : Use a sensor value and proportional <i>RHpi</i> : Use a sensor value and proportional-integral control band
MOD Mode	<i>Single CH</i> : Use a signal channel control signal <i>Dual CH</i> : Use a dual channel control signal
CNT Type	Setting not relevant when writing control signal through Modbus.

Note: Refer to the CONTROL SETTING section of the Nortec NH Series Installation and Operation Manual for more information on the above settings.

- 4 Press *Esc* repeatedly to return to the home screen when complete.

This procedure is summarized below:

Menu > 0335 > Control Settings >

Source: *Analog or Digital*

Reg Mode: *Demand, RHp, or RHpi*

Mod Mode: *Single CH or Dual CH*

CNT Type: *As required*

Modbus Parameters

The Nortec NHTC uses the following parameters for communication:

Signaling Type	EIA-485
Transmission Mode	RTU
Baud Rate	9600
Data Bits	8
Stop Bits	1
Parity	Even
Address / Unit Number	1*

**Default, may vary for multi-unit orders.*

It is important to note that the signaling type, transmission mode, baud rate, data bits and stop bits cannot be modified. Parity and unit address can be modified as required.

The following points may be mapped for control:

Table 4: Nortec NHTC Humidifier Modbus Parameters

Variable Name	Description	Addr.	Type	Format	Range	Unit	R/W	Details
CapLimitCyl1	Sets a manual capacity restriction for cylinder 1.	40026	Holding Register	Integer	50-100	%	Write	Limits output to percentage of total cylinder capacity
CapLimitCyl2	Sets a manual capacity restriction for cylinder 2 (if present).	41026	Holding Register	Integer	50-100	%	Write	Limits output to percentage of total cylinder capacity for cylinder 2 (Nortec NHTC-150 and Nortec NHTC-200 models only)
RHDemCyl1	Write RH or Demand signal value to control channel 1 for cylinder 1	40264	Holding Register	Integer	0 - 100	%	Write	Requires network controls (NetSensor = 1), for most common configurations this is the primary control signal
RHDemCyl2	Write RH or Demand signal value to control channel 1 for cylinder 2	41264	Holding Register	Integer	0 - 100	%	Write	Requires network controls (NetSensor = 1), only applies to Nortec NHTC-150 and Nortec NHTC-200 with cylinders in independent operation mode
RHDem2Cyl1	Write RH or Demand signal value to control channel 2 for cylinder 1	40265	Holding Register	Integer	0 - 100	%	Write	Requires network controls (NetSensor = 1), only applies to Nortec NHTC-150 and Nortec NHTC-200 with dual channel control enabled
RHDem2Cyl2	Write RH or Demand signal value to control channel 2 for cylinder 2	41265	Holding Register	Integer	0 - 100	%	Write	Requires network controls (NetSensor = 1), only applies to Nortec NHTC-150 and Nortec NHTC-200 with cylinders dual channel control enabled and cylinders in independent operation mode
Set1Cyl1	Writes the desired space setpoint for control channel 1 for cylinder 1	40024	Holding Register	Integer	30-95	%	Write	Use only when sending RH value to RHDem1, for most common configurations this is the primary space setpoint
Set1Cyl2	Writes the desired space setpoint for control channel 1 for cylinder 2	41024	Holding Register	Integer	30-95	%	Write	Use only with Nortec NHTC-150 and Nortec NHTC-200 models when sending RH value to RHDem1 and cylinders are in independent operation mode
Set2Cyl1	Writes the desired space setpoint for control channel 2 for cylinder 1	40010	Holding Register	Integer	30-95	%	Write	Use only when sending RH value to RHDem2 with dual channel control enabled

Variable Name	Description	Addr.	Type	Format	Range	Unit	R/W	Details
Set2Cyl2	Writes the desired space setpoint for control channel 2 for cylinder 2	41010	Holding Register	Integer	30-95	%	Write	Use only with Nortec NHTC-150 and Nortec NHTC-200 models when sending RH value to RHDem2 with dual channel control enabled and cylinders are in independent operation mode
DisableCyl1	Remotely disable steam production for cylinder 1	40262	Holding Register	Integer	0 or 255	-	Write	0 = Normal operation 255 = Disabled
DisableCyl2	Remotely disable steam production for cylinder 2	41262	Holding Register	Integer	0 or 255	-	Write	Used only for Nortec NHTC-150 and Nortec NHTC-200 models. Both cylinder 1 and 2 must be disabled to completely disable humidifier. 0 = Normal operation 255 = Disabled
NetSensor	Switches between hard wired or network control signal	40226	Holding Register	Integer	0 or 1	-	Write	1= Network sensor or demand 0 = Wired sensor or wired demand
Ch1DemCyl1	Displays channel 1 demand for cylinder 1	30348	Input Register	Integer	0 - 100	%	Read	Displays channel 1 demand as a percentage of cylinder capacity for cylinder 1
Ch1DemCyl2	Displays channel 1 demand for cylinder 2	31348	Input Register	Integer	0 - 100	%	Read	Displays channel 1 demand / output as a percentage of cylinder capacity for cylinder 2 (Nortec NHTC-150 and Nortec NHTC-200 models only)
Ch2DemCyl1	Displays channel 2 demand for cylinder 1	30349	Input Register	Integer	0 - 100	%	Read	Displays channel 2 demand as a percentage of cylinder capacity for cylinder 1
Ch2DemCyl2	Displays channel 2 demand for cylinder 2	31349	Input Register	Integer	0 - 100	%	Read	Displays channel 2 demand / output as a percentage of cylinder capacity for cylinder 2 (Nortec NHTC-150 and Nortec NHTC-200 models only)
Fault Warning	Reads fault status	30301	Input Register	Integer	0 or 255	-	Read	0 = No Fault 255 = Fault Warning
Service Warning	Reads service warning status	30300	Input Register	Integer	0 or 255	-	Read	0 = No Service Warning 255 = Service Warning
Unit Status	Reads unit status	30312	Input Register	Integer	0 or 255	-	Read	0 = Idle / Standby 255 = Active / Humidifying

Variable Name	Description	Addr.	Type	Format	Range	Unit	R/W	Details
Cyl1OpTime	Reads operating time for cylinder 1	30213	Input Register	Integer	0 - 65535	5 min	Read	Reads operating time for cylinder 1. Each number is equivalent to 5 minutes of operation. Time in hours = (Value x 5)/60
Cyl2OpTime	Reads operating time for cylinder 2	31213	Input Register	Integer	0 - 65535	5 min	Read	Reads operating time for cylinder 2 (Nortec NHTC-150 and Nortec NHTC-200 only). Each number is equivalent to 5 minutes of operation. Time in hours = (Value x 5)/60
UnitStatus	Displays status warnings	31385	Input Register	Integer	0-99	-	Read	11 = Security loop open 19 = Cylinder spent warning If status 19, unit will have yellow service light on and will continue to run for 72hrs
CylSpent	Displays cylinder end of life fault	30378	Input Register	Integer	0-99	-	Read	Unit will not run until cylinder is replaced 19 = Cylinder spend fault
SysTotalDem	Displays the total demand on system (sum both cylinders)	30251	Input Register	Integer	0 - 100	%	Read	Sum of Steam Output Cyl-1 and Cyl-2 in percentage

Nortec GSTC Gas Fired Steam Humidifiers

After wiring connections have been completed, the humidifier needs to be setup to operate and communicate through the Modbus interface.

Modbus Address

The default Modbus address for a Nortec GSTC is 1. If multiple units were included on an order, the addresses of individual units may vary.

To view or change the unit number:

- 1 Press the *Menu* key to access the menu.
- 2 When prompted for a password, enter 0335 using the arrow keys. Press *Set* to confirm.
- 3 Select the *Control Settings* menu and press the *Set* key.
- 4 Select the *Modbus Parameters* menu and press the *Set* key.
- 5 Select the *Address* setting and press *Set* to modify. Enter a value between 1 and 127 inclusive as desired and press *Set* to confirm the solution. It is recommended to leave the parity and timeout settings to their factory defaults (None1 and 300 respectively) unless communication problems occur.
- 6 Press *Esc* repeatedly until you return to the home screen.

This procedure is summarized below:

Menu > 0335 > Control Settings > Modbus Parameters >

Parity: *None1*

Addr: *1 (Default, 1 – 127 acceptable)*

Timeout: *300 seconds (Default, 5 – 600 acceptable)*

Control Signal Setting

By default the humidifier is configured operate on a hardwired control signal supplied through the unit terminal strip. This can be changed to allow the humidifier to function entirely through its Modbus interface.

To adjust this setting:

- 1 Press the *Menu* key to access the menu.
- 2 When prompted for a password, enter 0335 using the arrow keys. Confirm the password with set.
- 3 Select the *Control Settings* menu and press the *Set* key. The following settings can be adjusted:

Source:	<i>Analog</i> : Use hardwired control signal <i>Digital</i> : Write control signal through modbus interface
REG Mode:	<i>Demand</i> : Use a demand control signal <i>RHp</i> : Use a sensor value and proportional <i>RHpi</i> : Use a sensor value and proportional-integral control band
MOD Mode:	<i>Single CH</i> : Use a signal channel control signal <i>Dual CH</i> : Use a dual channel control signal
CNT Type:	Setting not relevant when writing control signal through modbus.

Note: Refer to the Nortec *GSTC Total Controller Flow Chart* section of the Nortec GS Series Installation and Operation Manual for more information on the above settings.

- 4 Press *Esc* repeatedly to return to the home screen when complete.

This procedure is summarized below:

Menu > 0335 > *Control Settings* >

Source: *Analog* or *Digital*

Reg Mode: *Demand*, *RHp*, or *RHpi*

Mod Mode: *Single CH* or *Dual CH*

CNT Type: *As required*

Modbus Parameters

The Nortec GSTC uses the following parameters for communication:

Signaling Type	EIA-485
Transmission Mode	RTU
Baud Rate	9600
Data Bits	8
Stop Bits	1
Parity	None
Address / Unit Number	1*

*Default, may vary for multi-unit orders.

It is important to note that the signaling type, transmission mode, baud rate, data bits and stop bits cannot be modified. Parity and unit address can be modified as required.

The following points may be mapped for control:

Table 5: Nortec GSTC Humidifier Modbus Parameters

Variable Name	Description	Addr	Type	Format	Range	Unit	R/W	Additional Details
RHDem1	Write RH or Demand signal value to control channel 1	40264	Holding Register	Analog	0-100	%	Write	Requires network controls (NetSensor = 1)
RhDem2	Write RH or Demand signal value to control channel 2	40265	Holding Register	Analog	0-100	%	Write	Requires network controls (NetSensor = 1)
Set1	Writes the desired space setpoint for control channel 1	40024	Holding Register	Analog	30-95	%	Write	Use only when sending RH value to RHDem1
Set2	Writes the desired space setpoint for control channel 2	40025	Holding Register	Analog	30-95	%	Write	Use only when sending RH value to RHDem2
Disable	Remotely disables the humidifier	40262	Holding Register	Analog	0, 255	-	Write	0 = Run 255 = Disable
InputType	Selects the control type that the humidifier operates on	40007	Holding Register	Analog	0,1,2,3	-	Write	0 = Demand Signal 1 = On/Off Signal 2 = RH Sensor Value (Use Proportional Control) 3 = RH Sensor Value (Use Proportional-Integral Control)
NetSensor	Switches between hard wired or network control signal	40226	Holding Register	Binary	0,1	-	Write	0 = Hard wired control signal 1 = Use Modbus to write control signal value
RHDem1	Read RH or Demand signal value from control Channel 1	30348	Input Register	Analog	0-100	%	Read	Displays signal value as a percentage
RHDem2	Read RH or Demand signal value from control Channel 2	30349	Input Register	Analog	0-100	%	Read	Displays signal value as a percentage
Set1	Read space setpoint for control channel 1	40024	Input Register	Analog	30-95	%	Read	Only available for InputType 2 or 3
Set2	Read space setpoint for control channel 2	40025	Input Register	Analog	30-95	%	Read	Only available for InputType 2 or 3
Disable	Confirms remote disable status	30989	Input Register	Analog	0, 255	-	Read	0 = Run 255 = Disable
InputType	Confirms the control type that the humidifier operates on	40007	Input Register	Analog	0,1,2,3	-	Read	0 = Demand Signal 1 = On/Off Signal 2 = RH Sensor Value (Use Proportional Control) 3 = RH Sensor Value (Use Proportional-Integral Control)
NetSensor	Confirms the system control type	40226	Input Register	Binary	0,1	-	Read	0 = Hard wired control signal 1 = Use Modbus to write control signal value

Variable Name	Description	Addr	Type	Format	Range	Unit	R/W	Additional Details
Fault	Read fault status	30301	Input Register	Binary	0,1	-	Read	0 = No Fault 1 = Fault Detected
Service	Read service warning status	30300	Input Register	Binary	0,1	-	Read	0 = No Service Warning 1 = Service Required
Status	Read humidification status	30302	Input Register	Binary	0,1	-	Read	0 = Idle / Standby 1 = Active / Humidifying
Connection	Read connection status	40267	Input Register	Binary	0,1	-	Read	0 = Communication Error 1 = Normal Communication
HourOpt	Read operational hours of unit	30350	Input Register	Analog	0 - Infinity	hrs	Read	Displays hours of operation.
KeepWarm	Read keepwarm option status (enable/disable at humidifier)	30356	Input Register	Analog	0,1	-	Read	Bit0 - KEEPWARM 0 = Disabled 1 = Enabled
3DayDrain	Read 3 day drain option status (enable/disable at humidifier)	30356	Input Register	Analog	0,1	-	Read	Bit1 - 3 DAY DRAIN 0 = Disabled 1 = Enabled
SysDemand	Read system output / demand	30347	Input Register	Analog	0-100	%	Read	Displays output as percentage of capacity
ServHours	Read hours before next service	30352	Input Register	Analog	500-0	hrs	Read	Displays hours remaining until next service.
SecurityLoop	Displays status of security loop.	30364	Input Register	Analog	0,1	-	Read	Displays the status of the security loop on terminals 1 and 2. Loop must be "closed" for humidifier to operate. 0 = Open 1 = Closed

Nortec SETC Steam Exchange Humidifiers

After wiring connections have been completed, the humidifier needs to be setup to operate and communicate through the Modbus interface.

Modbus Address

The default Modbus address for a Nortec SETC is 1. If multiple units were included on an order, the addresses of individual units may vary.

To view or change the unit number:

- 1 Press the *Menu* key to access the menu.
- 2 When prompted for a password, enter 0335 using the arrow keys. Press *Set* to confirm.
- 3 Select the *Control Settings* menu and press the *Set* key.
- 4 Select the *Modbus Parameters* menu and press the *Set* key.
- 5 Select the *Address* setting and press *Set* to modify. Enter a value between 1 and 127 inclusive as desired and press *Set* to confirm the solution. It is recommended to leave the parity and timeout settings to their factory defaults (None1 and 300 respectively) unless communication problems occur.
- 6 Press *Esc* repeatedly until you return to the home screen.

This procedure is summarized below:

Menu > 0335 > Control Settings > Modbus Parameters >

Parity: None1

Addr: 1 (Default, 1 - 127 acceptable)

Timeout: 300 seconds (Default, 5 - 600 acceptable)

Control Signal Setting

By default the humidifier is configured operate on a hardwired control signal supplied through the unit terminal strip. This can be changed to allow the humidifier to function entirely through its Modbus interface.

To adjust this setting:

- 1 Press the *Menu* key to access the menu.
- 2 When prompted for a password, enter 0335 using the arrow keys. Confirm the password with set.
- 3 Select the *Control Settings* menu and press the *Set* key. The following settings can be adjusted:

Source	<i>Analog:</i> Use hardwired control signal <i>Digital:</i> Write control signal through Modbus interface
REG Mode	<i>Demand:</i> Use a demand control signal <i>RHp:</i> Use a sensor value and proportional <i>RHpi:</i> Use a sensor value and proportional-integral control band
MOD Mode	<i>Single CH:</i> Use a signal channel control signal <i>Dual CH:</i> Use a dual channel control signal
CNT Type	Setting not relevant when writing control signal through Modbus.

Note: Refer to the Nortec *SETC Humidifier Configuration* section of the Nortec SE Series Installation and Operation Manual for more information on the above settings.

- 1 Press *Esc* repeatedly to return to the home screen when complete.

This procedure is summarized below:

Menu > 0335 > Control Settings >

Source: *Analog or Digital*

Reg Mode: *Demand, RHp, or RHpi*

Mod Mode: *Single CH or Dual CH*

CNT Type: *As required*

Modbus Parameters

The Nortec SETC uses the following parameters for communication:

Signaling Type	EIA-485
Transmission Mode	RTU
Baud Rate	9600
Data Bits	8
Stop Bits	1
Parity	None
Address / Unit Number	1*

*Default, may vary for multi-unit orders.

It is important to note that the signaling type, transmission mode, baud rate, data bits and stop bits cannot be modified. Parity and unit address can be modified as required.

The following points may be mapped for control:

Table 6: Nortec SETC Humidifier Modbus Parameters

Variable Name	Description	Addr	Type	Format	Range	Unit	R/W	Additional Details
RHDem1	Write RH or Demand signal value to control channel 1	40264	Holding Register	Analog	0-100	%	Write	Requires network controls (NetSensor = 1)
RhDem2	Write RH or Demand signal value to control channel 2	40265	Holding Register	Analog	0-100	%	Write	Requires network controls (NetSensor = 1)
Set1	Writes the desired space setpoint for control channel 1	40024	Holding Register	Analog	30-95	%	Write	Use only when sending RH value to RHDem1
Set2	Writes the desired space setpoint for control channel 2	40025	Holding Register	Analog	30-95	%	Write	Use only when sending RH value to RHDem2
Disable	Remotely disables the humidifier	40262	Holding Register	Analog	0, 255	-	Write	0 = Run 255 = Disable
InputType	Selects the control type that the humidifier operates on	40007	Holding Register	Analog	0,1,2,3	-	Write	0 = Demand Signal 1 = On/Off Signal 2 = RH Sensor Value (Use Proportional Control) 3 = RH Sensor Value (Use Proportional-Integral Control)
NetSensor	Switches between hard wired or network control signal	40226	Holding Register	Binary	0,1	-	Write	0 = Hard wired control signal 1 = Use Modbus to write control signal value
Read Parameters								
RHDem1	Read RH or Demand signal value from control Channel 1	30348	Input Register	Analog	0-100	%	Read	Displays signal value as a percentage
RHDem2	Read RH or Demand signal value from control Channel 2	30349	Input Register	Analog	0-100	%	Read	Displays signal value as a percentage
Set1	Read space setpoint for control channel 1	40024	Input Register	Analog	30-95	%	Read	Only available for InputType 2 or 3
Set2	Read space setpoint for control channel 2	40025	Input Register	Analog	30-95	%	Read	Only available for InputType 2 or 3
Disable	Confirms remote disable status	30989	Input Register	Analog	0, 255	-	Read	0 = Run 255 = Disable
InputType	Confirms the control type that the humidifier operates on	40007	Input Register	Analog	0,1,2,3	-	Read	0 = Demand Signal 1 = On/Off Signal 2 = RH Sensor Value (Use Proportional Control) 3 = RH Sensor Value (Use Proportional-Integral Control)
NetSensor	Confirms the system control type	40226	Input Register	Binary	0,1	-	Read	0 = Hard wired control signal 1 = Use Modbus to write control signal value
Diagnostic Parameters								
Fault	Read fault status	30301	Input Register	Binary	0,1	-	Read	0 = No Fault 1 = Fault Detected
Service	Read service warning status	30300	Input Register	Binary	0,1	-	Read	0 = No Service Warning 1 = Service Required

Variable Name	Description	Addr	Type	Format	Range	Unit	R/W	Additional Details
Status	Read humidification status	30302	Input Register	Binary	0,1	-	Read	0 = Idle / Standby 1 = Active / Humidifying
Connection	Read connection status	40267	Input Register	Binary	0,1	-	Read	0 = Communication Error 1 = Normal Communication
HourOpt	Read operational hours of unit	30350	Input Register	Analog	0 - Infinity	hrs	Read	Displays hours of operation.
KeepWarm	Read keepwarm option status (enable/disable at humidifier)	30356	Input Register	Analog	0,1	-	Read	Bit0 - KEEPWARM 0 = Disabled 1 = Enabled
3DayDrain	Read 3 day drain option status (enable/disable at humidifier)	30356	Input Register	Analog	0,1	-	Read	Bit1 - 3 DAY DRAIN 0 = Disabled 1 = Enabled
SysDemand	Read system output / demand	30347	Input Register	Analog	0-100	%	Read	Displays output as percentage of capacity
ServHours	Read hours before next service	30352	Input Register	Analog	500-0	hrs	Read	Displays hours remaining until next service.
SecurityLoop	Displays status of security loop.	30364	Input Register	Analog	0,1	-	Read	Displays the status of the security loop on terminals 1 and 2. Loop must be "closed" for humidifier to operate. 0 = Open 1 = Closed

Nortec MHTC Evaporative Media Humidifiers

After wiring connections have been completed, the humidifier needs to be setup to operate and communicate through the Modbus interface.

Modbus Address

The default Modbus address for a Nortec MHTC is 1. If multiple units were included on an order, the addresses of individual units may vary.

To view or change the unit number:

- 1 Press the *Menu* key to access the menu.
- 2 Select the *User* option and press *Set*.
- 3 When prompted for a password, enter 8808 using the arrow keys. Press *Set* to confirm.
- 4 Select the *Settings* menu and press the *Set* key.
- 5 Select the *Modbus* menu and press the *Set* key.
- 6 Select the *Address* setting and press *Set* to modify. Enter a value between 1 and 127 inclusive as desired and press *Set* to confirm the solution. It is recommended to leave the parity and timeout settings to their factory defaults (None1 and 300 respectively) unless communication problems occur.
- 7 Press *Esc* repeatedly until you return to the home screen.

This procedure is summarized below:

Menu > User > 8808 > Modbus >

Parity: None1

Addr: 1 (Default, 1 - 127 acceptable)

Timeout: 300 seconds (Default, 5 - 600 acceptable)

Control Signal Setting

By default the humidifier is configured operate on a hardwired control signal supplied through the unit terminal strip. This can be changed to allow the humidifier to function entirely through its Modbus interface.

To adjust this setting:

- 1 Press the *Menu* key to access the menu.
- 2 Select the *User* options and press *Set*.
- 3 When prompted for a password, enter 8808 using the arrow keys. Confirm the password with *set*.
- 4 Select the *Controls* menu and press the *Set* key. The following settings can be adjusted:

Signal Source	<i>Analog</i> : Use hardwired control signal <i>Modbus</i> : Write control signal through Modbus interface
Hum. Control	<i>External</i> : Use a demand control signal <i>Int(p)</i> : Use a sensor value and proportional <i>int(pi)</i> : Use a sensor value and proportional-integral control band
Control Sign	Setting not relevant when writing control signal through Modbus.

Note: Refer to the Nortec *MHTC Humidifier Configuration* section of the Nortec MH Series Installation and Operation Manual for more information on the above settings.

- 1 Press *Esc* repeatedly to return to the home screen when complete.

This procedure is summarized below:

Menu > *User* > 8808 > *Controls* >

Signal Source: *Analog* or *Modbus*

Hum. Control: *External*, *Int(p)*, or *Int(pi)*

Control Sign: *As required*

Modbus Parameters

The Nortec MHTC uses the following parameters for communication:

Signaling Type	EIA-485
Transmission Mode	RTU
Baud Rate	9600 (cannot be changed)
Data Bits	8
Stop Bits	1
Parity	None
Address / Unit Number	1*

*Default, may vary for multi-unit orders.

It is important to note that the signaling type, transmission mode, baud rate, data bits and stop bits cannot be modified. Parity and unit address can be modified as required.

The following points may be mapped for control:

Table 7: Nortec MHTC Humidifier Modbus Parameters

Variable Name	Description	Addr	Type	Format	Range	Unit	R/W	Details
CapLimit	Manual Capacity Limit	40008	Holding Register	Integer	30 - 100	%	Write	Limits unit output.
RHDem1	Reads/writes a control signal to the humidifier	40053	Holding Register	Integer	0 - 100	%	Write	Writes a control signal to the humidifier. This input only works if humidifier is set to network control (NetSensor set to 1) in the control settings. If the system is set to network control no signal is detected, the unit will display the modbus timeout error.
Set1	Reads/Writes the desired space setpoint	40005	Holding Register	Integer	10 - 90	%	Write	Used when Hum_Control = 2 or 3 only
Disable	Remotely disables humidifier	40052	Holding Register	Integer	0 or 1	-	Write	0 = Allow normal humidifier operation 1 = Remotely disables the humidifier
Hum_Control	Selects the control type that the humidifier operates on	40003	Holding Register	Integer	0 - 3	-	Write	0 = Demand Signal 1 = On/Off Signal 2 = RH Sensor Value (Use Proportional control method) 3 = RH Sensor Value (Use Proportional-Integral control method)
NetSensor	Switches between hard wired or network control signal	40002	Holding Register	Integer	0 or 1	-	Write	0 = Wired Analog Sensor/Demand 1 = Modbus/Remote Sensor/Demand
Stage1Dem	Indicates output from humidifier stage 1	30025	Input Register	Integer	0 or 1	-	Read	0 = Inactive 1 = Active

Variable Name	Description	Addr	Type	Format	Range	Unit	R/W	Details
Stage2Dem	Indicates output from humidifier stage 2	30026	Input Register	Integer	0 or 1	-	Read	0 = Inactive 1 = Active
Stage3Dem	Indicates output from humidifier stage 3	30027	Input Register	Integer	0 or 1	-	Read	0 = Inactive 1 = Active
Warning	Indicates warning status	30015	Input Register	Integer	0 or 1	-	Read	0 = No warning 1 = Warning
Service	Indicates maintenance requirement	30016	Input Register	Integer	0 or 1	-	Read	0 = No service required 1 = Service required
Fault	Indicates fault status	30017	Input Register	Integer	0 or 1	-	Read	0 = No error 1 = Error(s) detected
Cleaning	Indicates automatic stage cleaning cycle status	30018	Input Register	Integer	0 or 1	-	Read	0 = Inactive 1 = Active
TankDrain	Indicates automatic tank drain status	30019	Input Register	Integer	0 or 1	-	Read	0 = Inactive 1 = Active
PumpRunHr	Displays pump operational hours	30100	Input Register	Integer	0 - 65535	10 min	Read	1Bit = 10min (max. 10'922h)
UVRunHr	Displays UV lamp operational hours	30101	Input Register	Integer	0 - 65535	10 min	Read	1Bit = 10min (max. 10'922h)
ServTime	Displays unit operational hours	30102	Input Register	Integer	0 - 65535	10 min	Read	1Bit = 10min (max. 10'922h)
Security	Indicates security loop status (humidifier terminals 1 and 2)	30200	Input Register	Integer	0 or 1	-	Read	Humidifier will only operate when security loop is closed. 0 = Off 1 = On
TankLevel	Max Level Sensor	30202	Input Register	Integer	0 or 1	-	Read	0 = Tank below full level 1 = Tank full
System Ready	Indicates when the humidifier is ready to commence stages	30013	Input Register	Integer	0 or 1	-	Read	0 = System busy (cleaning or draining) 1 = System ready to Humidify

Nortec MES2 and Nortec RH2 Models

The default Modbus address for a humidifier is 1.

To view or change the unit number:

- 1 Establish Modbus communications and map desired points as indicated in the following table.
- 2 Read the current Modbus address from variable 40201.
- 3 Change this address by writing the desired value to 40201. Values of 1 – 255 are acceptable.

By default the Nortec MES2 and Nortec RH2 are configured operate on a control signal supplied through the unit terminal strip. This can be changed to allow the humidifier to function entirely through its Modbus interface. This is configured by removed Jumper 26 from the humidifier circuit board.

Jumper Position	Function
J26 Removed	Terminal strip control
J26 Installed	Modbus control

Nortec MES2 and Nortec RH2 Electrode Steam OEM Humidifiers

The Nortec MES2 and Nortec RH2 both use the following parameters for communication:

Signaling Type	EIA-485
Transmission Mode	RTU
Baud Rate	9600 (can be changed to 4800 bps or 19200 bps)
Data Bits	8
Stop Bits	1
Parity	Even
Address / Unit Number	1*

*Default, may vary for multi-unit orders.

The following points may be mapped for control:

Table 8: Nortec MES2 and Nortec RH2 Humidifier Modbus Parameters

Variable Name	Description	Addr	Type	Format	Range	Unit	R/W	Details
HumEnable	Configures how humidifier responds to modbus controls	40003	Holding Register	Integer	0,255	-	Write	<p>0 = Disable operation of humidifier (Default Value) 255 = Allow operation of humidifier within limits specified by CapLimit</p> <p>Notes: - If a valid Modbus message is not received within the timeout windows, this parameter reverts to 0. - This value cannot be set when the FORCE DRAIN is activated as. FORCE DRAIN temporarily sets this to value 0. - Jumper J26 must be installed to write any parameter over the Modbus. J26 sets it into the control mode. - Opening of the hardwired security loop (terminals 1 and 2) will override operation even if 255 is written.</p>
CapLimit	Imposes a maximum output limit as percentage of unit capacity.	40004	Holding Register	Integer	25 - 100	%	Write	<p>Values outside of 25 - 100% return an error. Default on startup = 25.</p>
ForceDrain	Manually initiates a drain period.	40005	Holding Register	Integer	0, 255	-	Write	<p>0 = Normal operation (Default) 255 = Initiate a 20 minute timer during which the drain is active.</p> <p>Notes: - During a force drain, humidification ceases. - Writing 0 during 20 minute period will cancel the drain. - After 20 minutes this value will revert to 0 and the humidifier will resume normal operation.</p>
ModAddress	Writes a new Modbus address for the humidifier.	40201	Holding Register	Integer	1-255	-	Write	<p>Default = 1. Values of 1 - 255 are acceptable. Changes to this variable do not take effect until the humidifier has been power cycled.</p>
Baud	Sets the Modbus baud rate	40202	Holding Register	Integer	0,1,2	-	Write	<p>Changes to this variable do not take effect until the humidifier has been power cycled. 0 = 4800 bps 1 = 9600 bps (Default) 2 = 19200 bps</p>
Parity	Set Modbus Parity	40203	Holding Register	Integer	0,1,2	-	Write	<p>Changes to this variable do not take effect until the humidifier has been power cycled. 0 = No parity 1 = Even parity (Default) 2 = Odd parity</p>

RunHrReset	Allows the run hour counter to be reset to 0, typically used following maintenance.	40006	Holding Register	Integer	0, 255	-	Write	Requires that HumEnable is set to 0 (disabled) first or ILLEGAL DATA error will occur. 255 = Reset the run time hours (reported in RunHrs) to 0. Value reverts to 0 after operation is complete.
Units	Switches between imperial (lbs/hr) and metric (kg/hr) units.	40204	Holding Register	Integer	0,1	-	Write	0 = Imperial (lbs/hr) 1 = Metric (kg/hr) Changes values reported in Model (40205) and SteamOutput (30105).
Model	Allows writing of humidifier capacity to match model.	40205	Holding Register	Integer	0 - 30	-	Write	Value represents maximum unit capacity, in lbs/hr, at 100% Fill Off Amps. Value cannot be written while HumEnable = 255 (operational). The Nortec MES-005 would be written as 5. (Default = 8)
Voltage	Unit voltage	40206	Holding Register	Integer	1 to 10	-	Write	Reads the jumper (J1 thru 6) pin settings and reports the voltage: 0: 110-120V (J6 installed) 1: 208V (J6 installed) 2: 220-240V (J5 installed) 3: 230V 4: 277V (J4 installed) 5: 347V 6: 380V (J3 installed) 7: 400V (J3 installed) 8: 415V (J3 installed) 9: 440-480V (J2 installed, Default) 10: 550-600V (J1 installed)
Phase	Unit voltage phases	40207	Holding Register	Integer	0,1,2	-	Write	0 = Single phase 1 = 3 phase (Default) 2 = 3 phase (6 electrode)
ForceReset	Resets the controller and restarts in standby.	40007	Holding Register	integer	0,255	-	Write	Write 255 to this register to reset the control. The controller will reset, restart, and remain in standby mode. After completion: - WasReset (40002)will read 255 (reset has occurred) - HumEnable (40003) will read 0 (unit is disabled)
TimeWindow	Sets the permissible window for modbus data to be written.	40208	Holding Register	Integer	0 - 255	-	Write	Each integer is a multiple of 200mS. Maximum time of 51 secs occurs when the register reads 255. A value of 0 disables the timeout, but can only be written with HumEnable (40003) is set to 0 (disabled).

Current	Displays current draw in Amps.	30104	Input Register	Integer	0 - 12495	Amps	Read	Each bit represents 0.0024 Amps, therefore 1 Amp = 416 bits. The Amp value does not clear when security loop is open and the demand is 0. The last detected value remains in the register.
SteamOutput	Displays the steam output in either Metric of Imperial units.	30105	Input Register	Integer	0 - 300	lbs/hr kg/hr	Read	Units are defined in Units (register 40204). Unit includes decimal point as integer value. Example: 17 = 1.7 (kg/hr or lbs/hr) This variable does not clear when the security loop is open and the demand 0. The last detected value remains in the register.
RunHrs	Run hour Counter	30106	Input Register	Integer	0 - 24000	min	Read	Steam production hours since last reset. Max possible 2000 hrs of operation. Each integer is a multiple of 5 minutes. Example: 1 = 5 minutes 12 = 60 minutes (1 hr)
Firmware	Displays unit firmware version.	30113	Input Register	Integer	-	-	Read	Example: 352 = Version 3.52
Status	Displays status of various components.	30107	Input Register	Integer	0 - 128	-	Read	Significant bits: 1 (Bit 0), 2 (Bit 1), 4 (Bit 2), 8 (Bit 3), 16 (Bit 4), 32 (Bit 5), 64 (Bit 6), 128 (Bit 7). Bit 0 = Contactor Bit 1 = Fill Valve Bit 2 = Drain Valve Bit 3 = Blower pack fan Bit 4 = Collective fault (see 30108 for details) Bit 5 = Humidifier Active A "1" in the appropriate bit location indicates that the component is active.
MaxOutput	Displays the maximum capacity of humidifier.	30111	Input Register	Integer	0 - 30	lbs/hr	Read	The maximum amount of steam per hour that the humidifier can produce in lbs/hr. This value is copied from Model (40205).
Modulation	Displays the value of modulating signal when a local modulating humidistat is used.	30102	Input Register	Integer	0-1023	-	Read	Values are displayed as whole numbers with 2 decimals places. Example: 1023 = 10.23 volts 500 = 5.00 volts A constant value of 1023 can indicate the jumper J10 is installed.
FaultCode	Indicates the presence of a fault and which fault has been detected.	30108	Input Register	Integer	0-32768	-	Read	0 = (Amber LED 1 flash) Excess current. 1 = (Amber LED 3 flash) High water level, no current. 2 = (Amber LED 2 flash) No current detected 3 = (Amber LED 4 flash) End of cylinder life.

CtrlStatus1	Describes controller hardware and jumper statuses.	30109	Input Register	Integer	0-32768	-	Read	<p>Uses significant bits 0 through 15 (1, 2, 4, 8, 16, 32, 64, 128, 256, 512, 1024, 2048, 4096, 8192, 16384, 32768 respectively).</p> <p>Bit 1 - Electrodes passing current (0 = On) Bit 2 - FAULT Relay (0 = On) Bit 3 - YELLOW LED (1 = Illuminated) Bit 4 - GREEN LED (0 = Illuminated) Bit 5 - FAN (1 = On) Bit 8 - High Water Input (0 = High Water)</p>
CtrlStatus2	Hardware status Port D_E	30110	Input Register	Integer	0-32768	-	Read	<p>Bit 4 - MODBUS Control Active (0 = J26 installed) Bit 9 - FILL (1 = Active) Bit 10 - DRAIN (1 = Active)</p>

Nortec NHRS Electric Steam Humidifiers

After wiring connections have been completed, the humidifier needs to be setup to operate and communicate through the Modbus interface.

Modbus Address

The default Modbus address for a Nortec NHRS is 1. If multiple units were included on an order, the addresses of individual units may vary.

To view or change the unit number:

- 1 Press both the ↑ and ↓ keys simultaneously to access the menu.
- 2 When prompted for a password, enter 8808 using the arrow keys.
- 3 Scroll through the menu until and select the *Modbus Address*.
- 4 Enter a value between 1 and 127 inclusive as desired.
- 5 Press both the ↑ and ↓ keys simultaneously to return to the main menu.

This procedure is summarized below:

↑ and ↓ > 8808 > *Modbus Address* > 1 to 127

Control Signal Setting

By default the humidifier is configured operate on a hardwired control signal supplied through the unit terminal strip. This can be changed to allow the humidifier to function entirely through its Modbus interface.

To adjust this setting:

- 1 Establish Modbus communications and map points as indicated in the following table.
- 2 Write a value of 1 to address 40039. A value of 1 indicates control through Modbus, a value of 0 indicates controls hardwire to terminal strip.

The control type can also be modified:

- 1 Press both the ↑ and ↓ keys simultaneously to access the menu.
- 2 When prompted for a password, enter 8808 using the arrow keys.
- 3 Scroll through the menu until and select the *Controller Func.*
- 4 Select *Off* for a demand type control, or *On* for sensor (transducer) control.
- 5 Press both the ↑ and ↓ keys simultaneously to return to the main menu.

Modbus Parameters

The Nortec NHRS uses the following parameters for communication:

Signaling Type	EIA-485
Transmission Mode	RTU
Baud Rate	9600
Data Bits	8
Stop Bits	1
Parity	None
Address / Unit Number	1*

**Default, may vary for multi-unit orders.*

The following points may be mapped for control:

Table 9: Nortec NHRS Humidifier Modbus Parameters

Variable Name	Description	Addr	Type	Format	Range	Unit	R/W	Details
CapLimit	Set a manual capacity restriction for the humidifier	40006	Holding Register	Integer	50-100	%	Write	Limits output to percentage of total capacity
RHDem	Write RH or Demand signal value to humidifier	40038	Holding Register	Integer	0-100	%	Write	Requires network controls (NetSensor = 1)
Set	Writes the desired space setpoint when using sensor controls	40024	Holding Register	Integer	30-95	%	Write	Use only when sending RH value to RHDem
NetSensor	Switches between hard wired or network control signal	40039	Holding Register	Integer	0,1	-	Write	1 = Use Modbus to write sensor or demand value 0 = Hard wired sensor or wired demand signal
Separator								
RHDem	Read RH or Demand signal value from humidifier	40008	Input Register	Integer	0-100	%	Read	Used with hardwired or network control signal
Set	Read space setpoint (sensor type controls only)	40024	Input Register	Integer	30-95	%	Read	Sensor controls only, not for demand type controls
CapLimit	Reads the manual capacity restriction for humidifier	40006	Input Register	Integer	50-100	%	Read	Adjust using writeable CapLimit variable
NetSensor	Confirms humidifier control mode	40039	Input Register	Integer	0,1	-	Read	1 = Use Modbus to write sensor or demand value 0 = Hard wired sensor or wired demand signal
Separator								
SysDemand	Read system output / demand	40007	Input Register	Integer	0-100	%	Read	Displays output as percentage of capacity
HourOpt	Read operation hours of unit	40009	Input Register	Integer	0-infinity	hrs	Read	Displays cumulative hours since startup
SmallHrs	Read minor maintenance hours remaining	40013	Input Register	Integer	0-6000	hrs	Read	Displays hours until next minor maintenance
LargeHrs	Read major maintenance hours remaining	40015	Input Register	Integer	0-6000	hrs	Read	Displays hours until next major maintenance
Status	Read humidification status	40036	Input Register	Integer	0,1	-	Read	0 = Idle / Standby 1 = Active / Humidifying
Service	Read service warning status	40037	Input Register	Integer	0,1	-	Read	0 = No Service Warning 1 = Service Required
Fault	Read fault status	40035	Input Register	Integer	0,1	-	Read	0 = No Fault 1 = Fault Detected
InputType	Read control signal mode	40025	Input Register	Integer	0,1	-	Read	0 = Demand Signal 1 = RH Sensor Signal ("Transducer Control")
Connection	Read communication status	40015	Input Register	Integer	0,1	-	Read	0 = Communication Error 1 = Normal Communications

Troubleshooting

Table 10: General Troubleshooting

Problem	Resolutions
Cannot see/change set point over Modbus.	<p>Check control type. Demand type controls use internal algorithms to generate a signal telling the humidifier to operate at a certain output percentage. These controls <u>do not</u> report the detected humidity level or set point to the humidifier. As a result the set point and space humidity levels cannot be monitored through Modbus when using demand controls.</p> <p>Sensor ("transducer") type controls report a sensed humidity value to the humidifier. The set point is configured at the humidifier and the humidifier uses internal algorithms to determine the output percentage. Since the humidifier knows both the set point and humidity level, these values may be monitored over the Modbus connection.</p>
Cannot establish communication.	<p>Check communication parameters. Condaire humidifiers are capable of Modbus RTU communication. Modbus TCP based systems require a gateway to translate the information.</p> <p>Check Parity, baud rate, and stop bits. Modifying parity and stop bit parameters may be necessary for some Modbus networks.</p>
Cannot read data from point	<p>Check addresses, some Modbus network controllers automatically prepend the "40" for input registers and "30" for input registers.</p> <p>Carefully ensure that addresses are mapped correctly. A single incorrect address may cause loss of communication or faults for an entire chain of humidifiers.</p> <p>Check data type, some Modbus network controllers default to integer or binary values depending on variable type.</p>
Only some registers report data.	<p>Check the baud rate being used on the Modbus network. Nortec NH-EL, Nortec NHTC, Nortec GSTC, Nortec SETC, Nortec MHTC, and Nortec NHRS units <u>only</u> support 9600 bps. Nortec MES-2 and Nortec RH2 units can support 4800 bps, 9600 bps, or 19200 bps for communications. Use of faster baud rates may cause data loss.</p> <p>Check the polling rate being used. High polling rates can interrupt responses from the previous poll of data causing incomplete data transfer. A recommended polling rate is once per minute.</p>
Humidifier will not respond to set point/sensor values/ demand values written over Modbus.	<p>Check that humidifier is configured for "Digital" or "Modbus" control. Refer to the "Control Signal Settings" section for your humidifier model.</p> <p>If the setting is "Analog" the humidifier will look for a control signal on the low voltage terminal strip only.</p>
Humidifier will not respond to hardwired controls.	<p>Check that humidifier is configured for "Analog" control. Refer to the "Control Signal Settings" section for your humidifier model. If the setting is "Digital" or "Modbus" the humidifier will look for a control value to be written over Modbus only.</p>

Intermittent Communications	<p>Check wire type and run length. Wire type should be 18 – 24 AWG, shielded twisted pair wire with 120 ohm characteristic impedance. Chains should not exceed 2000 feet in length.</p> <p>Look for wire runs in close proximity to equipment generating significant electrical noise (such as VFD's, medical equipment, X-ray machinery, servers, etc).</p> <p>Check that wire shield is terminated at one end only. Terminations at both ends cause shield to conduct electricity and can generate noise.</p> <p>Confirm correct polarity of conductors at each device. This problem can be the result of Net+ and Net- terminals being crossed.</p> <p>Check Modbus addresses for conflicts with any device. Each Modbus device on the network must have a unique address. Devices (humidifiers or otherwise) cannot share Modbus addresses.</p> <p>Ensure that no more than 8 devices are connected to a single chain/bus. Humidifiers should be of the same type (gas, electric, etc) but do not to be the same size.</p>
Invalid data	<p>Check Modbus addresses for conflicts. Each Modbus device on the network must have a unique address. Devices (humidifiers or otherwise) cannot share Modbus addresses.</p>
More variables or additional information is required from the humidifier.	<p>Contact Condair Technical Services for additional support.</p>
<p>NHTC / GSTC / SETC E-50 Error</p> <p>MHTC E-35 Error</p> <p>“Modbus Timeout”</p>	<p>This error is generated in cases where the humidifier is configured for control over the Modbus network and a value is not written without the timeout window. The timeout clock restarts each time a value is written (even if the same value is written repeatedly).</p> <p>The error is corrected by writing an appropriate value to the RHdem1 address:</p> <p>Nortec NH-EL - 40005 Nortec NHTC – 40264 Nortec GSTC – 40264 Nortec SETC – 40264 Nortec MHTC – 40053</p> <p>If it is desired to use hardwired controls instead of network controls, the humidifier must be configured as such. Refer to the <i>Control Signal Setting</i> section for your humidifier found earlier in this manual.</p>

Appendix A

Modbus – Field Retrofit for Nortec NHRS Models

Step A – Unpacking

The Field kit is used to provide a simple hardware interface between the humidifier and Modbus BMS RS485 connection. Because the Nortec NHRS Humidifier speaks a different language, a Translation card is provided with the hardware kit. First start by reviewing the contents of Modbus Field retrofit kit, you should have the following items:

- 1 Ribbon cable 10 pin to 20 pin
- 1 Translation Printed Circuit board (colour blue)
- 1 terminal strip (3 pole) with RJ 11 termination cable
- 4 Nylon Standoffs (white)
- 4 Nylon screws (white)

Step B – Hardware installation

- 1 Locate the main PCB board inside the humidifier.
- 2 Connect one end of the ribbon cable (10 pin end) to the Humidifier’s COM port.

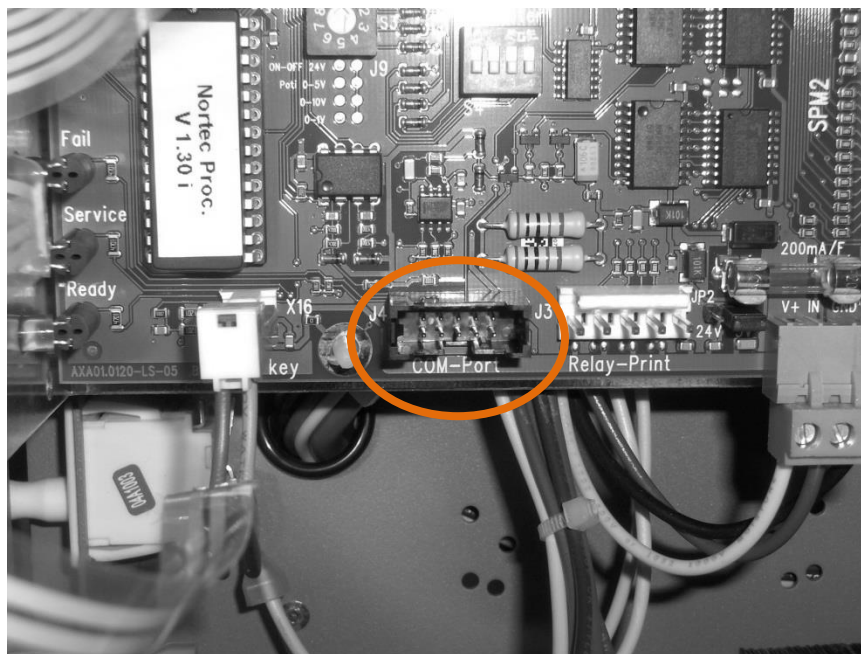

Figure 7: Humidifier COM port

- 3 Route the ribbon cable through the punch out on the humidifiers front electrical panel

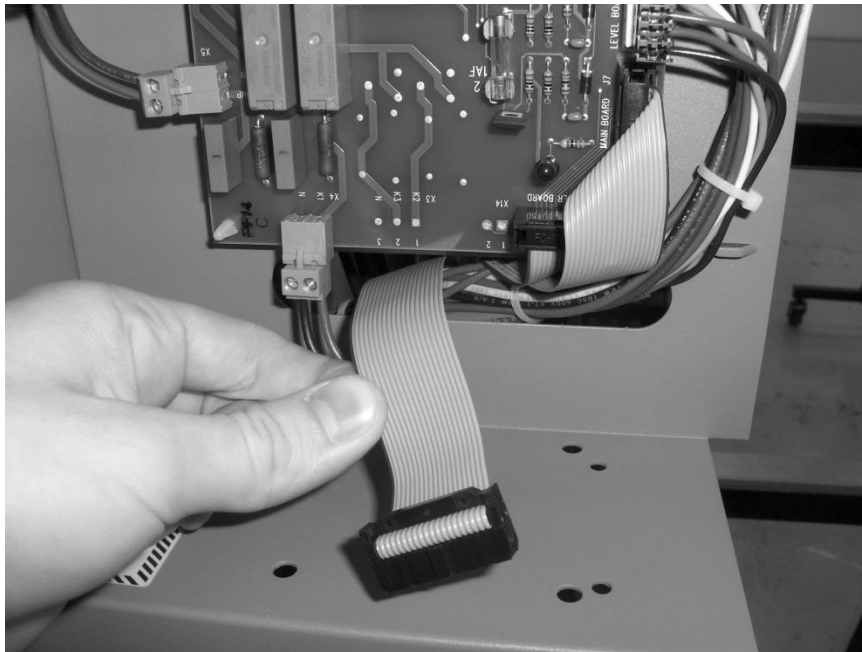

Figure 8: Routing of Ribbon Cable

- 4 Connect the ribbon cable 20 pin side to the Logic Card.

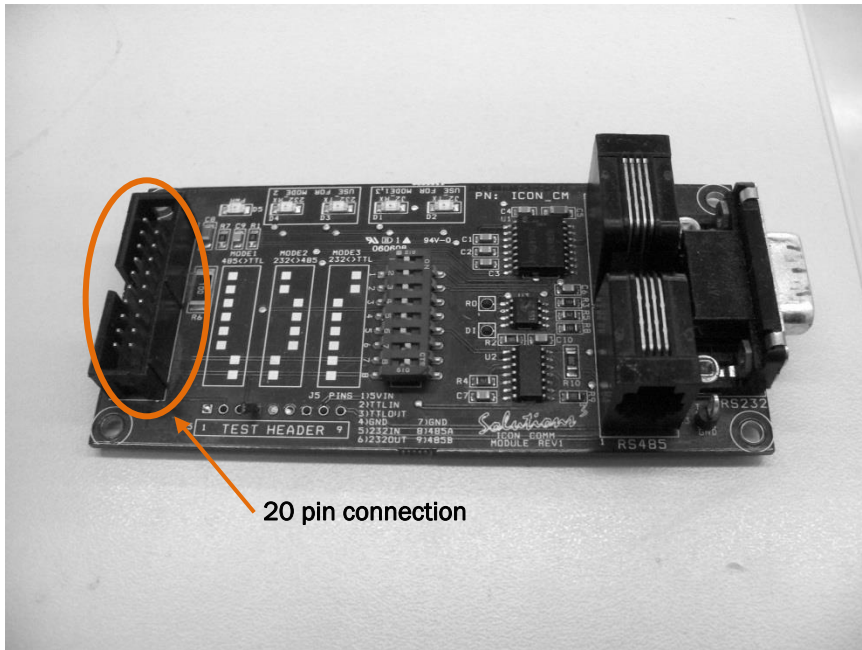

Figure 9: Pin connection for Ribbon cable

- 5 Configured dipswitch settings according to MODE1 printed on card (485<>TTL).

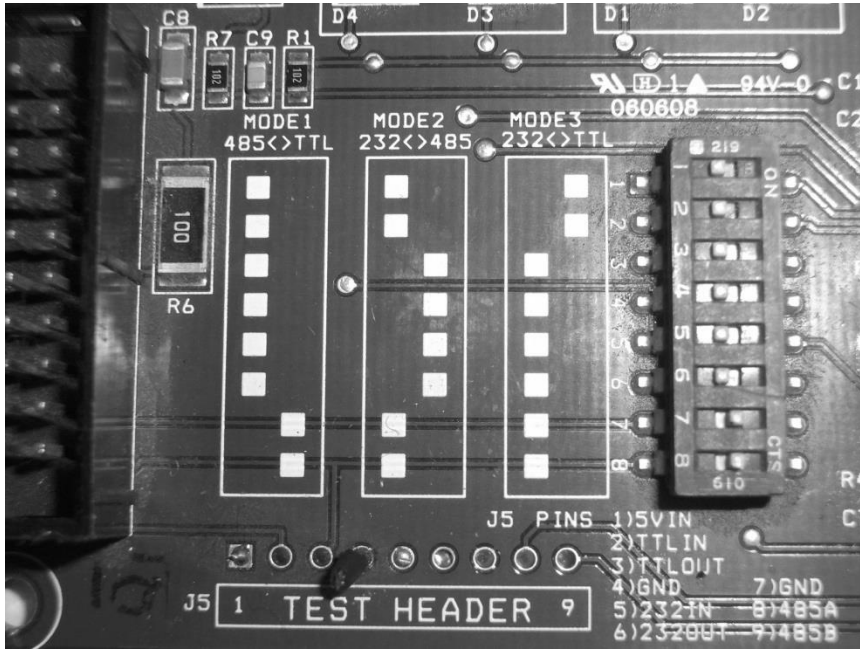

Figure 10: Dipswitch settings for Logic Card

- 6 Connect the RJ-11 cable to the corresponding jack on the logic card.

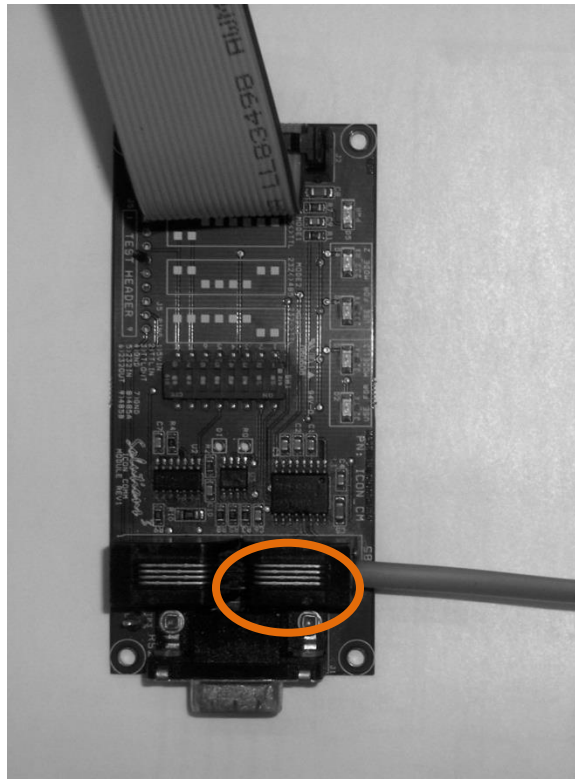

Figure 11: RJ-11 Jack Location on Logic Card

- 7 Mount logic card with nylon standoffs and screws to humidifier using the 4 pre-drilled holes

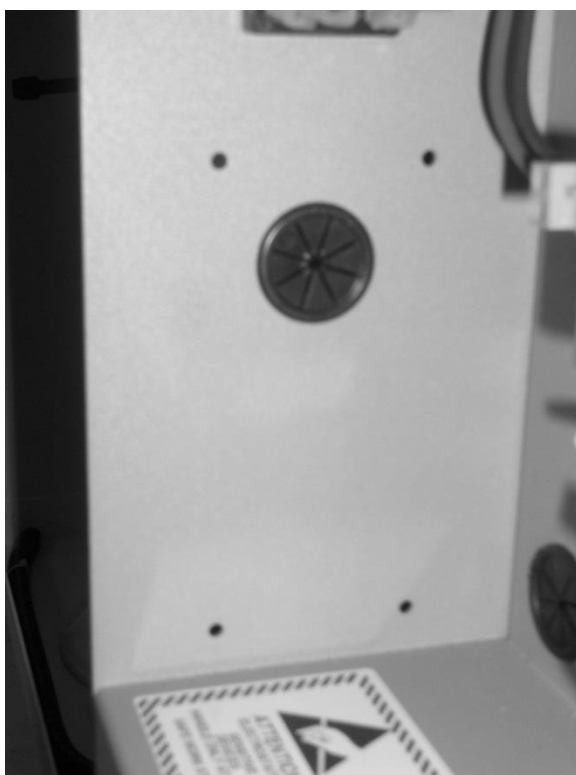

Figure 12: Pre drilled holes for Logic card

- 1** Mount the Terminal strip (3 pole) below or above the existing Nortec NHRS low voltage terminal strip



Figure 13: Low voltage terminal strip on Nortec NHRS Humidifier

Warranty

Condair Inc. and/or Condair Ltd. (hereinafter collectively referred to as THE COMPANY), warrant for a period of two years after installation or 30 months from manufacturer's ship date, whichever date is earlier, that THE COMPANY's manufactured and assembled products, not otherwise expressly warranted (with the exception of the cylinder), are free from defects in material and workmanship. No warranty is made against corrosion, deterioration, or suitability of substituted materials used as a result of compliance with government regulations.

THE COMPANY's obligations and liabilities under this warranty are limited to furnishing replacement parts to the customer, F.O.B. THE COMPANY's factory, providing the defective part(s) is returned freight prepaid by the customer. Parts used for repairs are warranted for the balance of the term of the warranty on the original humidifier or 90 days, whichever is longer.

The warranties set forth herein are in lieu of all other warranties expressed or implied by law. No liability whatsoever shall be attached to THE COMPANY until said products have been paid for in full and then said liability shall be limited to the original purchase price for the product. Any further warranty must be in writing, signed by an officer of THE COMPANY.

THE COMPANY's limited warranty on accessories, not of the companies manufacture, such as controls, humidistats, pumps, etc. is limited to the warranty of the original equipment manufacturer from date of original shipment of humidifier.

THE COMPANY makes no warranty and assumes no liability unless the equipment is installed in strict accordance with a copy of the catalog and installation manual in effect at the date of purchase and by a contractor approved by THE COMPANY to install such equipment.

THE COMPANY makes no warranty and assumes no liability whatsoever for consequential damage or damage resulting directly from misapplication, incorrect sizing or lack of proper maintenance of the equipment.

THE COMPANY makes no warranty and assumes no liability whatsoever for damage resulting from freezing of the humidifier, supply lines, drain lines, or steam distribution systems.

THE COMPANY retains the right to change the design, specification and performance criteria of its products without notice or obligation.

www.condairparts.com

Buy authentic Condair
parts factory direct.



U.S.A.
1021 6th Street
Racine, WI 53403

CANADA
2740 Fenton Road
Ottawa, Ontario K1T 3T7

TEL: 1.866.667.8321
FAX: 613.822.7964

EMAIL: na.info@condair.com
WEBSITE: www.condair.com



 **condair**